

TECHNICAL MANUAL

UNIT MAINTENANCE MANUAL

FOR

CARRIER, PERSONNEL, FULL TRACKED, ARMORED M113A3
2350-01-219-7577 (EIC AEY)

CARRIER, COMMAND POST, LIGHT TRACKED M577A3
2350-01-369-6085 (EIC AE7)

CARRIER, SMOKE GENERATOR, FULL TRACKED M1059A3
2350-01-369-6083 (EIC AFA)

CARRIER, MORTAR, 120-MM M121, SELF-PROPELLED M1064A3
2350-01-369-6082 (EIC AE8)

CARRIER, STANDARDIZED INTEGRATED COMMAND POST SYSTEM
(SICPS) M1068A3
2350-01-369-6086 (EIC AFC)

CARRIER, MECHANIZED SMOKE OBSCURANT M58
2350-01-418-6654 (EIC 5CG)

SUPERSEDURE NOTICE — This manual supersedes TM 9-2350-277-20 dated 24 July 1994, including all changes.

DISTRIBUTION STATEMENT A — Approved for public release; distribution is unlimited.

HEADQUARTERS, DEPARTMENT OF THE ARMY

2 January 2001

**TECHNICAL MANUAL
UNIT MAINTENANCE MANUAL
FOR**

**CARRIER, PERSONNEL, FULL TRACKED, ARMORED M113A3
2350-01-219-7577 (EIC AEY)**

**CARRIER, COMMAND POST, LIGHT TRACKED M577A3
2350-01-369-6085 (EIC AE7)**

**CARRIER, SMOKE GENERATOR, FULL TRACKED M1059A3
2350-01-369-6083 (EIC AFA)**

**CARRIER, MORTAR, 120-MM M121, SELF-PROPELLED M1064A3
2350-01-369-6082 (EIC AE8)**

**CARRIER, STANDARDIZED INTEGRATED COMMAND POST SYSTEM (SICPS) M1068A3
2350-01-369-6086 (EIC AFC)**

**CARRIER, MECHANIZED SMOKE OBSCURANT M58
2350-01-418-6654 (EIC 5CG)**

DISTRIBUTION STATEMENT A – Approved for public release; distribution is unlimited.

Remove Pages/Work Packages

WP 0594 00
WP 0595 00
WP 0596 00
WP 0597 00
WP 0598 00
WP 0599 00
WP 0600 00
WP 0601 00
WP 0602 00
WP 0603 00
WP 0604 00
WP 0605 00
WP 0615 00
Index
Cover

Insert Pages/Work Packages

None
None
None
None
None
None
None
None
None
WP 0602 00
WP 0603 00
WP 0604 00
None
WP 0615 00
Index
Cover

By Order of the Secretary of the Army:

Peter J. Schoomaker
*General, United States Army Official:
Chief of Staff*

Official:

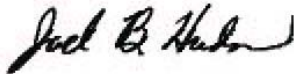

JOEL B. HUDSON
*Administrative Assistant to the
Secretary of the Army*
0327306

DISTRIBUTION:

To be distributed in accordance with the initial distribution number (IDN) 371205 requirements for TM 9-2350-277-20-4.

**TECHNICAL MANUAL
UNIT MAINTENANCE MANUAL
FOR**

**CARRIER, PERSONNEL, FULL TRACKED, ARMORED M113A3
2350-01-219-7577 (EIC AEY)**

**CARRIER, COMMAND POST, LIGHT TRACKED M577A3
2350-01-369-6085 (EIC AE7)**

**CARRIER, ANTI-TANK (TOW), FULL TRACKED, ARMORED M901A3
2350-01-369-7253 (EIC AFD)**

**CARRIER, FIRE SUPPORT PERSONNEL, FULL TRACKED, ARMORED M981A3
2350-01-369-6079 (EIC AFB)**

**CARRIER, SMOKE GENERATOR, FULL TRACKED M1059A3
2350-01-369-6083 (EIC AFA)**

**CARRIER, MORTAR, 120-MM M121, SELF-PROPELLED M1064A3
2350-01-369-6082 (EIC AE8)**

**CARRIER, STANDARDIZED INTEGRATED COMMAND POST SYSTEM (SICPS) M1068A3
2350-01-369-6086 (EIC AFC)**

**CARRIER, MECHANIZED SMOKE OBSCURANT M58
2350-01-418-6654 (EIC 5CG)**

DISTRIBUTION STATEMENT A – Approved for public release; distribution is unlimited.

TM 9-2350-277-20-4, 2 January 2001 is updated as follows:

1. File this change sheet in front of the publication for reference purposes.
2. New or updated text is indicated by a vertical bar in the outer margin of the page.
3. Revised illustrations are indicated by a miniature pointing hand adjacent to the updated area.
4. Remove old pages/Work Packages and insert new pages/Work Packages as indicated below.

Remove Pages/Work Packages

A/B
i-xxix/xxx blank
WP 0433 00
WP 0434 00
Chapter 17 WP Index
WP 0443 00
WP 0485 00
WP 0487 00
NEW
NEW
WP 0626 00
NEW
Index

Insert Pages/Work Packages

A/B blank
i-xxx
WP 0433 00
WP 0434 00
Chapter 17 WP Index
WP 0443 00
WP 0485 00
WP 0487 00
WP 0536 01
WP 0537 01
WP 0626 00
WP 0626 01
Index

Official:



JOEL B. HUDSON

*Administrative Assistant to the
Secretary of the Army*
0133208

PETER J. SCHOOMAKER
*General, United States Army
Chief of Staff*

DISTRIBUTION:

To be distributed in accordance with the initial distribution number (IDN) 371205 requirements for TM 9-2350-277-20-4.

INSERT LATEST UPDATED PAGES/WORK PACKAGES. DESTROY SUPERSEDED DATA.

LIST OF EFFECTIVE PAGES/WORK PACKAGES

Note: Updates to all portions of this TM are indicated by a vertical bar in the outer margin of the page.

Dates of issue for original and updated pages/work packages are:

- Original 0 (2 January 2001)
- Change 1 (5 September 2003)
- Change 2 (2 October 2003)

TOTAL NUMBER OF PAGES FOR FRONT AND REAR MATTER IS 154 AND TOTAL NUMBER OF WORK PACKAGES IS 191 CONSISTING OF THE FOLLOWING:

Page/WP No.	*Change No.	Page/WP No.	*Change No.	Page/WP No.	*Change No.
Title	2	WP 0498 00-0520 00	0		
A – B	2	WP 0521 00	2		
i-ix/x blank	2	WP 0522 00-0525 00	0		
Chapter 13 WP Index	0	WP 0526 00	2		
WP 0413 00-0416 00	2	WP 0527 00-0530 00	0		
WP 0417 00-0419 00	0	WP 0531 00	2		
WP 0419 01 (Added)	2	WP 0532 00-0535 00	0		
WP 0420 00	2	WP 0536 00	0		
WP 0420 01 (Added)	2	WP 0536 01	1		
WP 0421 00	2	WP 0537 00	0		
WP 0421 01 (Added)	2	WP 0537 01	1		
WP 0422 00	2	WP 0538 00 (Deleted)	0		
WP 0422 01 (Added)	2	WP 0539 00	0		
WP 0423 00	2	WP 0540 00-0541 00 (Deleted)	0		
WP 0423 01 (Added)	2	WP 0542 00-0547 00	0		
WP 0424 00	2	WP 0548 00 (Deleted)	0		
WP 0424 01-0424 01 (Added)	2	WP 0549 00-0564 00	0		
WP 0425 00	0	WP 0565 00 (Deleted)	0		
WP 0426 00	2	WP 0566 00-0567 00	0		
WP 0426 01 (Added)	2	WP 0568 00	2		
Chapter 14 WP Index	0	WP 0569 00-0574 00	0		
WP 0427 00-0432 00	0	WP 0575 00	2		
Chapter 15 WP Index	1	WP 0575 01 (Added)	2		
WP 0433 00-0434 00	1	WP 0576 00	2		
Chapter 16 WP Index	0	WP 0577 00-582 00	0		
WP 0435 00-0437 00	0	WP 0583 00-WP 0585 00 (Deleted)	0		
Chapter 17 WP Index	2	WP 0586 00	2		
WP 0438 00-042 00	0	WP 0587 00-0601 00 (Deleted)	2		
WP 0443 00	1	WP 0602 00-0604 00	2		
WP 0444 00-0454 00	0	WP 0605 00 (Deleted)	0		
WP 0455 00	2	WP 0606 00-0614 00	0		
WP 0456 00-0473 00	0	WP 0615 00	2		
WP 0474 00-0475 00	2	WP 0616 00-0625 00	0		
WP 0476 00-0477 00 (Deleted)	0	WP 0626 00	1		
WP 0478 00-0479 00	2	WP 0626 01	1		
WP 0480 00-0484 00	0	Index 1-Index103/104 blank	2		
WP 0485 00	1	DA2028/Back	0		
WP 0486 00	0	Authentication Page	0		
WP 0487 00	1	Metric Chart	0		
WP 0488 00-0496 00	0	Back Cover	0		
WP 0497 00	2				

Change 2

*Zero in this column indicated an original page.

HEADQUARTERS
DEPARTMENT OF THE ARMY
WASHINGTON, D.C., 02 January 2001

TECHNICAL MANUAL**UNIT MAINTENANCE MANUAL**

CARRIER, PERSONNEL, FULL TRACKED, ARMORED M113A3
NSN 2350-01-219-7577
(EIC AEY)

CARRIER, COMMAND POST, LIGHT TRACKED M577A3
NSN 2350-01-369-6085
(EIC AE7)

CARRIER, SMOKE GENERATOR, FULL TRACKED M1059A3
NSN 2350-01-369-6083
(EIC AFA)

CARRIER, MORTAR, 120-MM M121, SELF-PROPELLED M1064A3
NSN 2350-01-369-6082
(EIC AE8)

CARRIER, STANDARDIZED INTEGRATED COMMAND POST SYSTEM (SICPS) M1068A3
NSN 2350-01-369-6086
(EIC AFC)

CARRIER, MECHANIZED SMOKE OBSCURANT M58
NSN 2350-01-418-6654
(EIC 5CG)

REPORTING ERRORS AND RECOMMENDING IMPROVEMENTS

You can help improve this publication. If you find any mistakes or if you know of a way to improve the procedures, please let us know. Submit your DA Form 2028-2 (Recommended Changes to Equipment Technical Publications), through the Internet, on the Army Electronic Product Support (AEPS) website. The internet address is <http://aeeps.ria.army.mil>. If you need a password, scroll down and click on "ACCESS REQUEST FORM". The DA 2028 is located in the ONLINE FORMS PROCESSING section of the AEPS. Fill out the form and click on SUBMIT. Using this form on the AEPS will enable us to respond quicker to your comments and better manage the DA Form 2028 program. You may also mail, fax, or E-mail your letter, DA Form 2028 or DA Form 2028-2 direct to: Technical Publication Information Office, TACOM-RI, 1 Rock Island Arsenal, Rock Island, IL 61299-7630. The email address is TACOM-TECH-PUBS@ria.army.mil. The fax number is DSN 793-0726 or Commercial (309)782-0726.

SUPERSEDURE NOTICE — This manual supersedes TM 9-2350-277-20 dated 24 July 1994, including all changes.

DISTRIBUTION STATEMENT A — Approved for public release; distribution is unlimited.

TABLE OF CONTENTS

WP Sequence No.

Volume 4

CHAPTER 13 — UNIT MAINTENANCE INSTRUCTIONS FOR WHEELS AND TRACKS

REPLACE TORSION BAR.....	0413 00
REPLACE TORSION BAR ANCHOR.....	0414 00
REPLACE ROAD WHEEL SUPPORT ARM, BEARINGS, AND SEALS.....	0415 00
REPLACE ROAD WHEEL HUB	0416 00
REPLACE IDLER WHEEL ARM ASSEMBLY	0417 00
REPLACE IDLER WHEEL ARM BEARINGS AND SEALS.....	0418 00
REPLACE TRACK TENSION ADJUSTER AND MOUNT	0419 00
REVERSE T150 TRACK DRIVE SPROCKET AND TRACK ASSEMBLIES	0419 01
REPLACE T130 DRIVE SPROCKET WHEEL ASSEMBLY	0420 00
REPAIR T150 SPROCKET WHEEL ASSEMBLY	0420 01
REPAIR T130 DRIVE SPROCKET WHEEL ASSEMBLY.....	0421 00
REPLACE T130 TRACK	0422 00
REPLACE T150 TRACK	0422 01
REPLACE T130 TRACK SHOE ASSEMBLY.....	0423 00
REPLACE T150 TRACK SHOE ASSEMBLY.....	0423 01
REPLACE T130 TRACK SHOE PAD.....	0424 00
REPLACE T150 TRACK SHOE PAD.....	0424 01
REPLACE IDLER WHEEL	0425 00
REPLACE ROAD WHEEL (T130).....	0426 00
REPLACE ROAD WHEEL (T150).....	0426 01

CHAPTER 14 — UNIT MAINTENANCE INSTRUCTIONS FOR STEERING

ADJUST STEERING WHEEL LINKAGE.....	0427 00
REPLACE STEERING LOCK SOLENOID, BRACKET, LINKS, AND PINS (SOLENOID-ACTIVATED LOCK).....	0428 00
REPLACE PUSH-PULL CONTROL ASSEMBLY, BRACKET, LINKS, AND PINS (CABLE-ACTIVATED LOCK).....	0429 00
REPLACE STEERING WHEEL LINKAGE	0430 00
REPLACE QUICK RELEASE PIN AND LANYARD.....	0431 00

TABLE OF CONTENTS (cont)

	<u>WP Sequence No.</u>
REPLACE STEERING SUPPORT, BRACKETS, AND SHAFT	0432 00
CHAPTER 15 — UNIT MAINTENANCE INSTRUCTIONS FOR TOWING ATTACHMENTS	
REPLACE TOWING PINTLE	0433 00
REPAIR TOWING PINTLE.....	0434 00
CHAPTER 16 — UNIT MAINTENANCE INSTRUCTIONS FOR SHOCK ABSORBERS	
REPLACE SHOCK ABSORBER.....	0435 00
REPLACE SHOCK ABSORBER MOUNT	0436 00
REPLACE SHOCK ABSORBER PIN	0437 00
CHAPTER 17 — UNIT MAINTENANCE INSTRUCTIONS FOR HULL	
REPLACE TRACK SHROUD AND COVERS.....	0438 00
REPAIR/REPLACE POWER PLANT REAR ACCESS PANELS	0439 00
REMOVE/INSTALL FAN DRIVE PULLEY ACCESS COVER	0440 00
REPLACE DRIVER’S POWER PLANT ACCESS PANEL	0441 00
REPAIR PAMPHLET BAG MOUNTING	0442 00
REPLACE TOWING HOOK AND EYE.....	0443 00
REPLACE LIFTING EYE.....	0444 00
REPLACE REAR TIEDOWN PLATES	0445 00
REPLACE HEADLIGHT GUARD.....	0446 00
REPLACE LEFT FRONT ARMOR PLATE	0447 00
REPLACE RIGHT FRONT ARMOR PLATE.....	0448 00
REPLACE HULL FRONT ACCESS COVER.....	0449 00
REPLACE POWER PLANT BOTTOM ACCESS COVER.....	0450 00
REPLACE HULL DRAIN PLUG	0451 00
REPLACE FINAL DRIVE HULL DRAIN PLUGS	0452 00
REPLACE DRIVER’S COMPARTMENT FLOOR PLATES.....	0453 00
REPLACE REAR COMPARTMENT AIR VENTILATOR.....	0454 00
REPLACE SMOKE GRENADE LAUNCHER GUARD, PLATE, AND BASE (M113A3 AND M1059A3 ONLY).....	0455 00
REPLACE WATER BARRIER (M113A3, M577A3, AND M1068A3 ONLY).....	0456 00
REPLACE WATER BARRIER LOOP AND STRAP (M113A3, M577A3, AND M1068A3 ONLY).....	0457 00
REPLACE TRIM VANE	0458 00
REPAIR TRIM VANE (ALL EXCEPT M58).....	0459 00
REPAIR TRIM VANE (M58 ONLY)	0460 00
REPAIR TRIM VANE CONTROL LINKAGE.....	0461 00

TABLE OF CONTENTS (cont)

	<u>WP Sequence No.</u>
REPLACE TRIM VANE RELEASE.....	0462 00
REPAIR TRIM VANE RELEASE	0463 00
RAISE AND LOWER POWER PLANT GRILLE.....	0464 00
REMOVE/INSTALL POWER PLANT GRILLE	0465 00
REPLACE COMBAT FILLER COVER AND LOCK.....	0466 00
REPLACE POWER PLANT GRILL SUPPORT ARM.....	0467 00
REPLACE POWER PLANT GRILL SCREEN	0468 00
REPLACE RADIATOR ACCESS DOOR	0469 00
REPLACE POWER PLANT DOOR (M113A3 ONLY).....	0470 00
REPLACE POWER PLANT DOOR (ALL EXCEPT M113A3).....	0471 00
REPAIR POWER PLANT DOOR.....	0472 00
REPLACE POWER PLANT DOOR COMBAT LOCK	0473 00
REPLACE CARGO HATCH HOLD-OPEN HOOK AND BUMPERS (M113A3 AND M1059A3 ONLY).....	0474 00
REPLACE CARGO HATCH INTERIOR LATCH (M113A3 AND M1059A3 ONLY)	0475 00
DELETED.....	0476 00
DELETED.....	0477 00
REPLACE CARGO HATCH SEALS (M113A3 AND M1059A3 ONLY)	0478 00
REPLACE CARGO HATCH COVER (M113A3 AND M1059A3 ONLY)	0479 00
REPLACE MORTAR HATCH EXTERIOR CATCHES AND BUMPERS (M1064A3 ONLY)	0480 00
REPLACE MORTAR HATCH INTERIOR RELEASE MECHANISMS (M1064A3 ONLY)	0481 00
REPLACE MORTAR HATCH COVERS (M1064A3 ONLY).....	0482 00
REPLACE HOPPER HATCH LOCK ASSEMBLY (M58 ONLY).....	0483 00
REPLACE HOPPER HATCH (M58 ONLY).....	0484 00
REPLACE TURBINE ACCESS DOOR (M58 ONLY)	0485 00
REPLACE TURBINE ACCESS DOOR GASKET (M58 ONLY).....	0486 00
REPLACE TURBINE ACCESS DOOR HINGES (M58 ONLY).....	0487 00
REPLACE COMMANDER'S CUPOLA CUSHIONING PAD AND HANDLE (M113A3, M1059A3, M58, AND M1064A3 ONLY)	0488 00
REPLACE COMMANDER'S CUPOLA AZIMUTH LOCK (M113A3, M1059A3, M58 AND M1064A3 ONLY).....	0489 00
REPLACE COMMANDER'S CUPOLA VISION BLOCK LOCKS AND SEALS (M113A3, M1059A3 AND M58 ONLY).....	0490 00
REPLACE COMMANDER'S CUPOLA VISION BLOCK LOCKS AND SEALS (M1064A3 ONLY)	0491 00
REPLACE COMMANDER'S CUPOLA BRAKE ASSEMBLY (M113A3, M1059A3, M58, AND M1064A3 ONLY)	0492 00

TABLE OF CONTENTS (cont)

	<u>WP Sequence No.</u>
REPLACE COMMANDER’S CUPOLA COVER (M113A3, M1059A3, M58, AND M1064A3 ONLY)	0493 00
REPLACE COMMANDER’S CUPOLA HOLD-OPEN HOOK AND BUMPER (M113A3, M1059A3, M58, AND M1064A3 ONLY)	0494 00
REPLACE COMMANDER’S CUPOLA SAFETY PIN STOWAGE BLOCK (M113A3, M1059A3, M58, AND M1064A3 ONLY)	0495 00
REPLACE COMMANDER’S CUPOLA INTERIOR LATCH (M113A3, M1059A3, M58, AND M1064A3 ONLY)	0496 00
REPLACE COMMANDER’S CUPOLA MACHINE GUN MOUNT (M113A3, M1059A3, M58, AND M1064A3 ONLY)	0497 00
REPAIR COMMANDER’S CUPOLA MACHINE GUN MOUNT (M113A3, M1059A3, M58, AND M1064A3 ONLY)	0498 00
REPLACE COMMANDER’S CUPOLA MACHINE GUN MOUNT STOPS (M1059A3 ONLY)	0499 00
REPLACE COMMANDER’S HATCH CUSHIONING PAD AND HANDLE (M577A3 AND M1068A3 ONLY)	0500 00
REPLACE COMMANDER’S HATCH HOOK AND BUMPER (M577A3 AND M1068A3 ONLY)	0501 00
REPLACE COMMANDER’S HATCH INTERIOR LATCH (M577A3 AND M1068A3 ONLY)	0502 00
REPLACE COMMANDER’S HATCH COVER (M577A3 AND M1068A3 ONLY)	0503 00
REPLACE RIGHT SIDE SPALL LINERS (M113A3 ONLY)	0504 00
REPLACE LEFT SIDE SPALL LINERS (M113A3 ONLY)	0505 00
REPAIR SPALL LINER QUICK RELEASE PINS AND PLATES (M113A3 ONLY)	0506 00
REPLACE FORWARD SPALL LINER AND BRACKET (M113A3 ONLY)	0507 00
REPLACE FORWARD UPPER RIGHT AND LEFT SIDE SPALL LINERS (M113A3 ONLY)	0508 00
REPLACE SPALL LINER ON CARGO HATCH COVER (M113A3 ONLY)	0509 00
REPLACE REAR UPPER HULL SPALL LINER (M113A3 ONLY)	0510 00
REPLACE SPALL LINER ON RAMP DOOR (M113A3 ONLY)	0511 00
REPLACE SPALL LINER ON RAMP (M113A3 ONLY)	0512 00
RAISE/LOWER INOPERABLE/UNSAFE RAMP	0513 00
REPLACE RAMP SEAL	0514 00
REPLACE RAMP DRAIN PLUGS	0515 00
REPLACE RAMP BRACKET (M113A3, M577A3, AND M1068A3 ONLY)	0516 00
REPLACE RAMP DOOR STOP BRACKET	0517 00
REPLACE RAMP DOOR HOOK AND SPRING	0518 00
REPLACE RAMP DOOR HANDLES AND SHAFT	0519 00
REPLACE RAMP DOOR SEAL	0520 00

TABLE OF CONTENTS (cont)

	<u>WP Sequence No.</u>
ADJUST RAMP LOCK (M113A3 AND M1059A3 ONLY).....	0521 00
ADJUST RAMP LOCK (M577A3 AND M1068A3 ONLY).....	0522 00
ADJUST RAMP LOCK (M1064A3 ONLY).....	0523 00
REPLACE RAMP LOCK HANDLE AND ARMS (ALL EXCEPT M577A3 AND M1068A3).....	0524 00
REPLACE RAMP LOCK LEVER AND CABLE (M577A3 AND M1068A3 ONLY)	0525 00
REPLACE RAMP LINKAGE (M113A3 AND M1059A3 ONLY).....	0526 00
REPLACE RAMP LINKAGE (M577A3 AND M1068A3 ONLY).....	0527 00
REPLACE RAMP LINKAGE (M1064A3 ONLY)	0528 00
REPAIR HULL BY WELDING	0529 00
REPLACE DRIVER’S HATCH CUSHIONING PAD	0530 00
REPLACE DRIVER’S HATCH COVER AND EXTERIOR LOCK	0531 00
REPLACE DRIVER’S HATCH HOLD-OPEN HOOK AND BUMPER (M113A3, M1059A3, M1064A3, AND M58 ONLY).....	0532 00
REPLACE DRIVER’S HATCH HOLD-OPEN HOOK AND BUMPER (M577A3 AND M1068A3 ONLY).....	0533 00
REPLACE DRIVER’S HATCH INTERIOR LOCK AND LATCH.....	0534 00
REPLACE DRIVER’S HATCH VISION BLOCK LOCKS AND SEALS	0535 00
REPLACE DRIVER’S HATCH AN/VVS-2 DRIVER’S NIGHT VISION GUARD (ALL EXCEPT M58)	0536 00
REPLACE DRIVER’S HATCH NIGHT VISION GUARD (M58 ONLY).....	0536 01
REPLACE AN/VVS-2 DRIVER’S NIGHT VISION MOUNT (ALL EXCEPT M58)	0537 00
REPLACE DRIVER’S HATCH NIGHT VISION MOUNT (M58 ONLY)	0537 01
DELETED.....	0538 00
REPLACE FLOOR PLATES (M113A3 AND M577A3 ONLY)	0539 00
DELETED.....	0540 00
DELETED.....	0541 00
REPLACE FLOOR PLATES (M1059A3 ONLY)	0542 00
REPLACE FLOOR PLATES (M1064A3 ONLY)	0543 00
REPLACE FLOOR PLATES (M1068A3 ONLY)	0544 00
REPLACE FLOOR PLATES (M58 ONLY)	0545 00
REPLACE PERSONNEL SEATS, CUSHIONS, AND BELTS (M113A3 ONLY)	0546 00
REPLACE PERSONNEL SEAT, CUSHION, AND BELTS (M577A3 ONLY)	0547 00
DELETED.....	0548 00
REPLACE PERSONNEL SEATS, BACKRESTS, CUSHIONS, AND BELTS (M1059A3 ONLY) ..	0549 00
REPLACE PERSONNEL SEATS, BACKRESTS, CUSHIONS, AND BELTS (M1064A3 ONLY) ..	0550 00
REPLACE DRIVER’S SEAT ASSEMBLY.....	0551 00

TABLE OF CONTENTS (cont)

	<u>WP Sequence No.</u>
REPAIR DRIVER’S SEAT	0552 00
REPLACE DRIVER’S SEAT BACK ASSEMBLY	0553 00
REPAIR DRIVER’S SEAT BACK ASSEMBLY	0554 00
REPLACE DRIVER’S SEAT IMPACT ABSORBER.....	0555 00
REPLACE DRIVER’S SEAT POST ASSEMBLY.....	0556 00
REPAIR DRIVER’S SEAT POST ASSEMBLY	0557 00
REPLACE DRIVER’S FOOTREST.....	0558 00
REPLACE/REPAIR COMMANDER’S PLATFORM (M113A3, M1059A3, M1064A3, AND M58 ONLY).....	0559 00
REPLACE COMMANDER’S SEAT AND POST (M113A3, M1059A3, AND M58 ONLY).....	0560 00
REPLACE COMMANDER’S SEAT AND POST (M1064A3 ONLY).....	0561 00
REPAIR COMMANDER’S SEAT (M113A3, M1059A3, M1064A3, AND M58 ONLY).....	0562 00
REPLACE COMMANDER’S JUMP SEAT (M113A3 ONLY).....	0563 00
REPLACE/REPAIR COMMANDER’S PLATFORM AND POST (M577A3 AND M1068A3 ONLY)	0564 00
DELETED.....	0565 00 ■
REPLACE/REPAIR COMMANDER’S SEAT (M1068A3 ONLY).....	0566 00
REPLACE/REPAIR OPERATOR’S SEAT (M1059A3 ONLY).....	0567 00
REPLACE/REPAIR RADIO OPERATOR’S SEAT (M1068A3 AND M58 ONLY)	0568 00 ■
REPLACE WEBBING STRAPS.....	0569 00
REPLACE CUSHIONING PADS	0570 00
REPLACE TOOL BOX LOOPS	0571 00
REPLACE AN/VVS-2 DRIVER’S NIGHT VISION STOWAGE MOUNT (ALL EXCEPT M58)	0572 00
REPLACE RIFLE BRACKETS	0573 00
REPLACE OIL CAN BRACKET	0574 00
REPLACE ANTENNA GUARDS	0575 00 ■
REPLACE T150 TRACK SHOE STOWAGE BRACKET.....	0575 01
REPLACE ANTENNA COVERS	0576 00
REPLACE LEFT BULKHEAD RADIO STOWAGE RACKS (M577A3 AND M1068A3 ONLY).....	0577 00
REPLACE LEFT TABLE (M577A3 ONLY).....	0578 00
REPLACE RIGHT FRONT RADIO STOWAGE RACK (M577A3 ONLY)	0579 00
REPLACE MAP BOARD (M577A3 ONLY)	0580 00
REPLACE RIGHT FORWARD TABLE (M577A3 ONLY).....	0581 00
REPLACE RIGHT REARWARD TABLE (M577A3 ONLY).....	0582 00

TABLE OF CONTENTS (cont)

	<u>WP Sequence No.</u>
DELETED.....	0583 00
DELETED.....	0584 00
DELETED.....	0585 00
REPLACE/REPAIR RAMP VISION PORT AND SHIELD (M58 ONLY).....	0586 00
DELETED.....	0587 00
DELETED.....	0588 00
DELETED.....	0589 00
DELETED.....	0590 00
DELETED.....	0591 00
DELETED.....	0592 00
DELETED.....	0593 00
DELETED.....	0594 00
DELETED.....	0595 00
DELETED.....	0596 00
DELETED.....	0597 00
DELETED.....	0598 00
DELETED.....	0599 00
DELETED.....	0600 00
DELETED.....	0601 00
REPLACE ANTENNA SUPPORT (M58 ONLY).....	0602 00
REPLACE CABLE REEL HOLDER ASSEMBLY (M1064A3 ONLY).....	0603 00
REPAIR CABLE REEL HOLDER ASSEMBLY (M1064A3 ONLY).....	0604 00
DELETED.....	0605 00
REPLACE HORIZONTAL AMMUNITION RACK (M1064A3 ONLY).....	0606 00
REPAIR HORIZONTAL AMMUNITION RACK (M1064A3 ONLY).....	0607 00
REPLACE VERTICAL AMMUNITION RACK (M1064A3 ONLY).....	0608 00
REPLACE RADIO STOWAGE RACK (M1064A3 ONLY).....	0609 00
REPLACE GRENADE STOWAGE BOX (M1064A3 ONLY).....	0610 00
REPLACE PERISCOPE STOWAGE BOX (M1064A3 ONLY).....	0611 00
REPLACE RIFLE RACK (M1064A3 ONLY).....	0612 00
REPLACE SIGHT EXTENSION ARM STOWAGE BRACKETS (M1064A3 ONLY).....	0613 00
REPLACE WINDSHIELD STOWAGE BRACKET (M1064A3 ONLY).....	0614 00
REPLACE MORTAR BASE STOWAGE BRACKET (M1064A3 ONLY).....	0615 00
REPLACE LEFT SIDE RACK BASE (M1068A3 ONLY).....	0616 00
REPLACE PERSONNEL HEATER CONTROL BOX AND INTERCOM BOX BRACKET (M1068A3 ONLY).....	0617 00

TABLE OF CONTENTS (cont)

	<u>WP Sequence No.</u>
REPLACE/REPAIR MAP BOARD (M1068A3 ONLY)	0618 00
REPLACE MAP STORAGE BOX (M1068A3 ONLY)	0619 00
REPAIR MAP STORAGE BOX (M1068A3 ONLY)	0620 00
REPLACE RIGHT SIDE SHELF ASSEMBLY (M1068A3 ONLY)	0621 00
REPLACE RIGHT SIDE RACK BASE (M1068A3 ONLY).....	0622 00
REPLACE RIGHT SIDE BASE EXTENSION (M1068A3 ONLY)	0623 00
REPLACE RIGHT SIDE BASE EXTENSION SUPPORTS (M1068A3 ONLY).....	0624 00
REPLACE/REPAIR ANTENNA MAST BRACKET ASSEMBLY, TAILLIGHT WIRING HARNESS, AND BRACKET (M1068A3 ONLY).....	0625 00
REPLACE REAR EXTERNAL STOWAGE FRAME (M1068A3 ONLY).....	0626 00
REPLACE STOWAGE BRACKETS FOR W1, W2, AND NATO SLAVE CABLES (M1068A3 AND M577A3).....	0626 01

CHAPTER 13

UNIT MAINTENANCE INSTRUCTIONS
FOR WHEELS AND TRACKS

WORK PACKAGE INDEX	
<u>Title</u>	<u>WP Sequence No.</u>
REPLACE TORSION BAR.....	0413 00
REPLACE TORSION BAR ANCHOR.....	0414 00
REPLACE ROAD WHEEL SUPPORT ARM, BEARINGS, AND SEALS.....	0415 00
REPLACE ROAD WHEEL HUB	0416 00
REPLACE IDLER WHEEL ARM ASSEMBLY	0417 00
REPLACE IDLER WHEEL ARM BEARINGS AND SEALS.....	0418 00
REPLACE TRACK TENSION ADJUSTER AND MOUNT	0419 00
REVERSE T150 TRACK DRIVE SPROCKET AND TRACK ASSEMBLIES	0419 01
REPLACE T130 DRIVE SPROCKET WHEEL ASSEMBLY	0420 00
REPAIR T150 SPROCKET WHEEL ASSEMBLY	0420 01
REPAIR T130 DRIVE SPROCKET WHEEL ASSEMBLY.....	0421 00
REPLACE T130 TRACK	0422 00
REPLACE T150 TRACK	0422 01
REPLACE T130 TRACK SHOE ASSEMBLY.....	0423 00
REPLACE T150 TRACK SHOE ASSEMBLY.....	0423 01
REPLACE T130 TRACK SHOE PAD.....	0424 00
REPLACE T150 TRACK SHOE PAD.....	0424 01
REPLACE IDLER WHEEL	0425 00
REPLACE ROAD WHEEL (T130).....	0426 00
REPLACE ROAD WHEEL (T150).....	0426 01

REPLACE TORSION BAR

0413 00

THIS WORK PACKAGE COVERS:

- Removal (page 0413 00-1).
- Installation (page 0413 00-4).

INITIAL SETUP:

Maintenance Level

Unit

Tools and Special Tools

- General Mechanic's Tool Kit (WP 0926 00, Item 65)
- Adapter (WP 0926 00, Item 6)
- Road Wheel Lifter (WP 0926 00, Item 28)
- Socket Head Cap Screw (WP 0926 00, Item 45)
- Puller (WP 0926 00, Item 38)
- Socket Wrench Attachment (WP 0926 00, Item 53)
- Torque Wrench (WP 0926 00, Item 85)

Materials/Parts

- Grease (WP 0928 00, Item 12)

Personnel Required

- Unit Mechanic
- Helper (H)

References

- See your -10

Equipment Condition

- Engine stopped (see your -10)
- Carrier on level surface
- Carrier blocked (see your -10)
- Track shroud and covers removed (WP 0438 00)
- Road wheel removed (T130) (WP 0426 00)
- Road wheel removed (T150) (WP 0426 01)
- Shock absorber removed from second or fifth road wheel (WP 0435 00)
- Power plant removed for first torsion bar, right side only (WP 0156 00)
- Driver's front floor plate removed for first torsion bar, left side only (WP 0453 00)
- Power plant rear access panel removed for second torsion bar, right side only (see your -10)
- Driver's rear floor plate removed for second torsion bar, left side only (WP 0453 00)
- Floor plates removed for third and fourth torsion bar (WP 0539 00), (WP 0542 00), (WP 0543 00), (WP 0544 00), or (WP 0545 00)

REMOVAL

WARNING

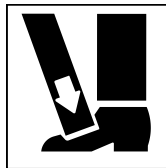

If road wheel lifter slips while lowering road arm, it could injure you. Stand clear before you lower road arm.

REPLACE TORSION BAR — Continued**0413 00**

1. With road wheel removed and road arm raised on lifter, start engine (see your -10). Place range selector in 1. Slowly drive carrier forward off lifter so that road wheel support arm (1) hangs freely.
2. Remove screw (2) from plug (3).

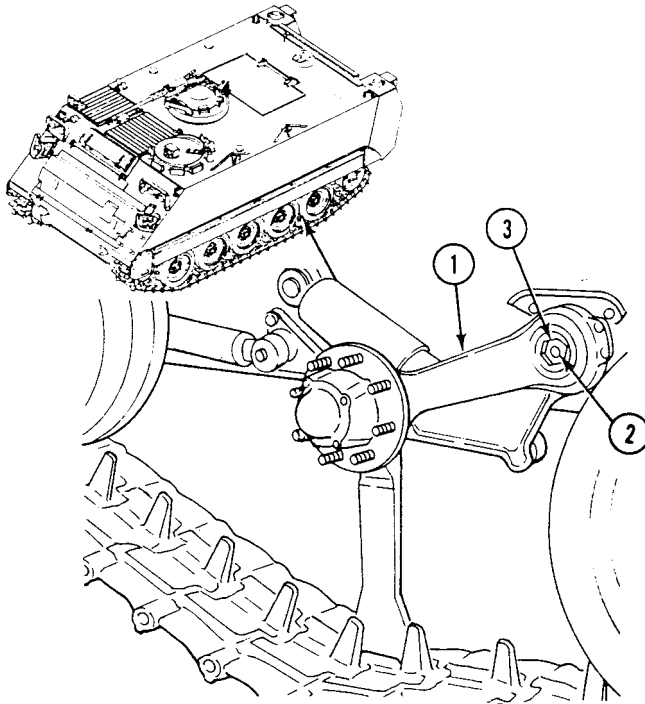

3. Remove plug (1) from road wheel support arm (2). Use socket wrench attachment.

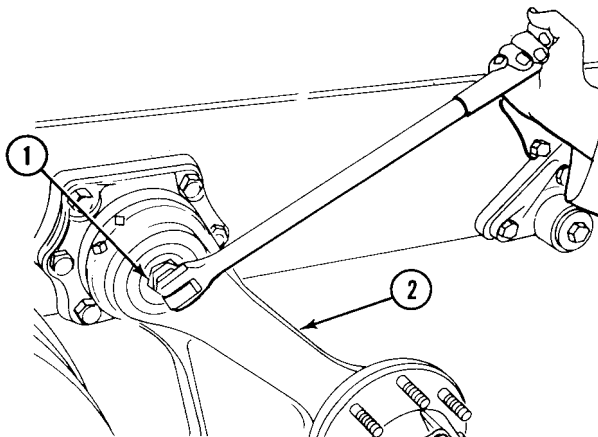
**NOTE**

Special socket head cap screw is used with adapter.

4. Thread special screw through adapter.

NOTE

Screw is installed with head inside adapter.

5. Thread adapter on puller, then thread adapter with screw into torsion bar.

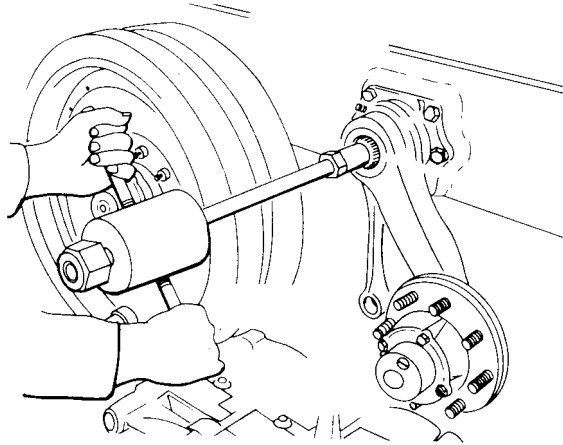
**CAUTION**

When removing or installing torsion bars, the index or missing tooth on the anchor end of torsion bar must align with index on spline in road wheel arm, to allow bar to pass through.

6. Pull torsion bar (3) from torsion bar anchor (4). Use slide hammer on puller.
7. Remove puller and adapter from torsion bar.
8. If torsion bar (3) is broken, remove as follows:
 - a. Remove road wheel end of torsion bar in the same way as unbroken torsion bar.
 - b. Pull or drive end of broken bar from its splined seat in torsion bar anchor (4).

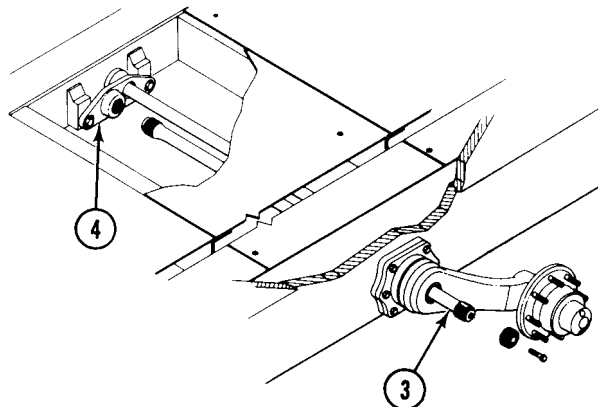

INSTALLATION**CAUTION**

When removing or installing torsion bars, the index or missing tooth on the anchor end of torsion bar must align with index on spline in road wheel arm, to allow bar to pass through.

CAUTION

Align index or missing tooth on end of torsion bar with index on road wheel arm and torsion bar anchor before installing.

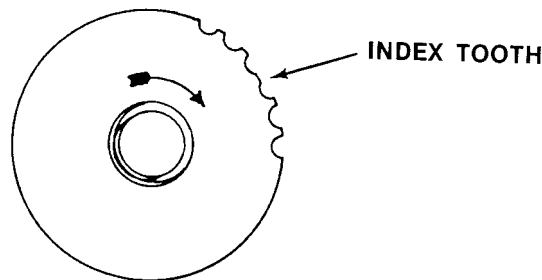
**CAUTION**

Handle torsion bar with care. Do not tear or cut wrapping.

NOTE

Left and right torsion bars are not interchangeable. To determine correct bar, place arrow on end of torsion bar outboard, with arrow at top. Arrow must point toward front of carrier.

1. Thread puller with adapter and screw into torsion bar.
2. Install torsion bar (1) through road wheel arm (2) and anchor (3). (H) Guide torsion bar into anchor to ensure proper alignment. Use slide hammer on puller to seat torsion bar.
3. Remove puller and adapter from torsion bar.
4. Put a light coat of grease on threads of plug (4). Install plug in road wheel arm (2).
5. TIGHTEN PLUG (4) TO 50-75 LB-FT (68-102 N·m) TORQUE. Use socket wrench attachment.

6. Install screw (5) in plug (4).

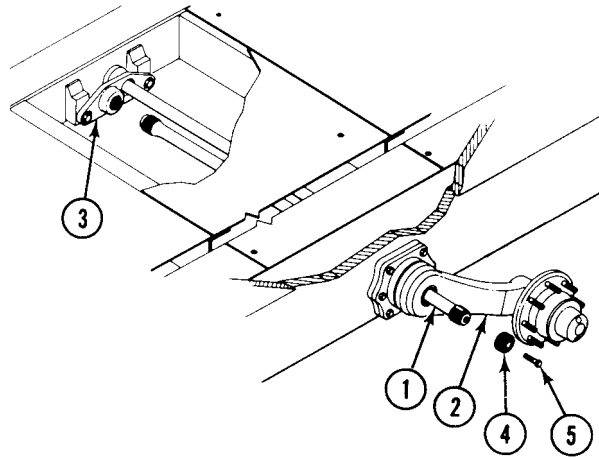

NOTE

You may need to jack carrier to raise road arm, before positioning road wheel lifter.

7. Position road wheel lifter (WP 0426 00) (T130) or (WP 0426 01) (T150).

FOLLOW-THROUGH STEPS

1. Install floor plates for third and fourth torsion bars (WP 0539 00), (WP 0542 00), WP 0543 00), (WP 0544 00), or (WP 0545 00).
2. Install driver's rear floor plate for second torsion bar, left side only (WP 0453 00).
3. Install power plant rear access panel for second torsion bar, right side only (see your -10).
4. Install driver's front floor plate for first torsion bar, left side only (WP 0453 00).
5. Install power plant for first torsion bar, right side only (WP 0156 00).
6. If removed, install shock absorber (WP 0435 00).
7. Install road wheel (WP 0426 00) (T130) or (WP 0426 01) (T150).
8. Install track shroud and covers (WP 0438 00).
9. Unblock carrier (see your -10).
10. Road test carrier to check that torsion bar is installed right (WP 0155 00).

END OF TASK

REPLACE TORSION BAR ANCHOR

0414 00

THIS WORK PACKAGE COVERS:

Removal (page 0414 00-1).
 Installation (page 0414 00-3).

INITIAL SETUP:

Maintenance Level

Unit

References

See your -10

Tools and Special Tools

General Mechanic's Tool Kit (WP 0926 00, Item 65)
 Socket Wrench Set (Required for M1064A3 5th anchor only) (WP 0926 00, Item 73)
 Torque Wrench (Required for M1064A3 5th anchor only) (WP 0926 00, Item 86)

Equipment Condition

Carrier on level surface
 Engine stopped (see your -10)
 Carrier blocked (see your -10)
 Track shroud and covers removed (WP 0438 00)
 Road wheel removed (T130) (WP 0426 00)
 Road wheel removed (T150) (WP 0426 01)
 Torsion bar removed (WP 0413 00)
 Power plant removed (Required for 2nd right anchor only) (WP 0156 00)

Materials/Parts

Cotter pin (2)
 Preformed packing (Required for 3rd, 4th, & 5th anchors only)

Personnel Required

Unit Mechanic

REMOVAL

NOTE

The 5th anchor on the M1064A3 carrier is secured with screws instead of pins because it is located under the welded floor plates next to the mortar turntable.

NOTE

On all carriers, preformed packings are located behind the 3rd, 4th, and 5th anchors only.

1. Remove two cotter pins (1), pins (2), anchor (3), and preformed packing (4) (3rd, 4th, and 5th anchors only) from lugs on hull floor. Discard cotter pins and preformed packing.

NOTE

Do Step 2 for M1064A3 5th anchor only.

2. Raise mortar turntable tread plate and remove two screws (5), anchor (3), and preformed packing (4) from bosses under floorplate next to turntable. Discard preformed packing.

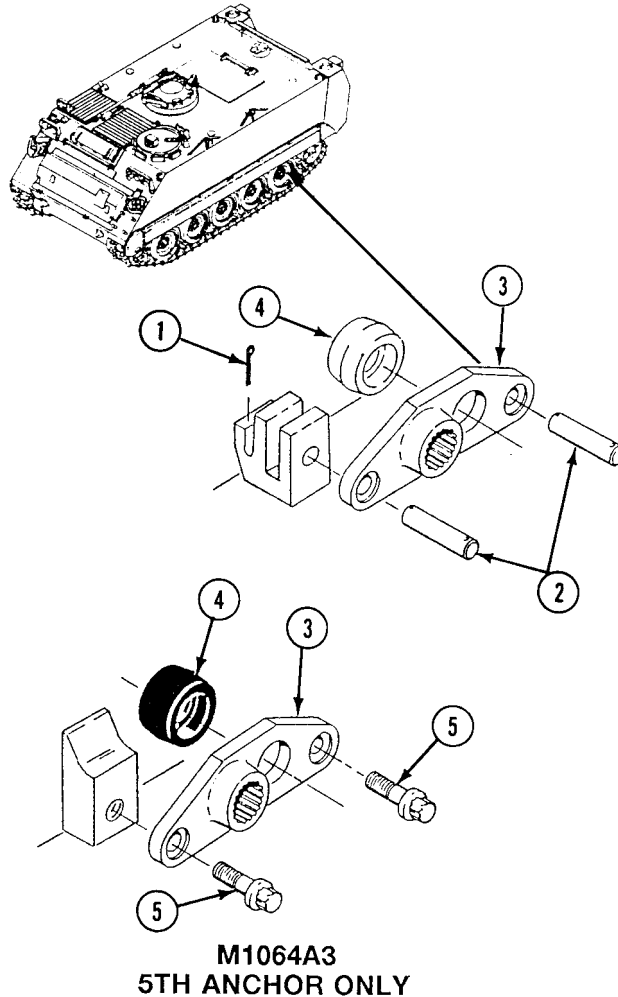

INSTALLATION

NOTE

Check anchor and pins for wear and damage. Replace if needed.

NOTE

Do Step 1 for M1064A3 5th anchor only.

1. Install new preformed packing (1) and anchor (2) on bosses under floorplate next to turntable. Secure with two screws (3). TIGHTEN SCREWS TO 320-330 LB-FT (434-447 N·m) TORQUE.

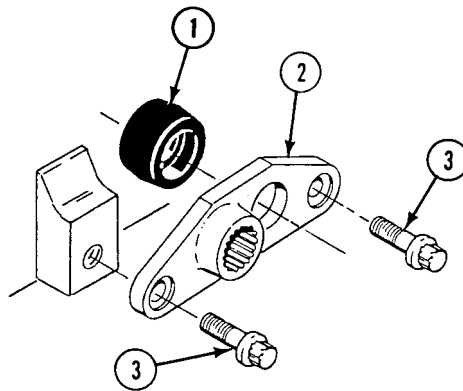

**M1064A3
5TH ANCHOR ONLY**

NOTE

Cotter pins must not prevent full 360° rotation of anchor pins.

2. Install new preformed packing (1) (3rd, 4th, and 5th anchors only), anchor (2), and two pins (4) in lugs on hull floor. Secure with two new cotter pins (5). Bend cotter pins as shown. Ensure pins (4) are free to rotate through 360 degrees.

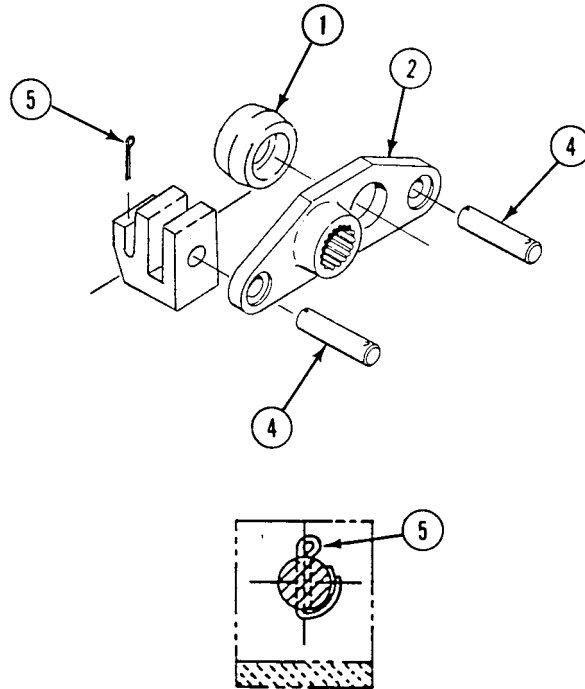
**FOLLOW-THROUGH STEPS**

1. Install torsion bar (WP 0413 00).
2. Install power plant (if removed for 2nd right anchor only) (WP 0156 00).
3. Install road wheel (T130) (WP 0426 00).
4. Install road wheel (T150) (WP 0426 01).
5. Install track shroud and covers (WP 0438 00).
6. Unblock carrier (see your -10).
7. Start engine (see your -10).
8. Road test carrier to check that torsion bar anchor is installed properly (WP 0155 00).
9. Stop engine (see your -10).

END OF TASK

REPLACE ROAD WHEEL SUPPORT ARM, BEARINGS, AND SEALS

0415 00

THIS WORK PACKAGE COVERS:

- Removal (page 0415 00-1).
- Installation (page 0415 00-4).

INITIAL SETUP:

Maintenance Level

Unit

Personnel Required

Unit Mechanic

Tools and Special Tools

- General Mechanic's Tool Kit (WP 0926 00, Item 65)
- Remover and Replacer (WP 0926 00, Item 41)
- Torque Wrench (WP 0926 00, Item 83)
- Torque Wrench (WP 0926 00, Item 82)

References

See your -10

Materials/Parts

- Grease (WP 0928 00, Item 12)
- Sealing compound (WP 0928 00, Item 50)
- Inner seal
- Outer seal
- Retainer gasket
- Road arm housing bearing (2)
- Road arm housing packing
- Tablock washer (3)

Equipment Condition

- Carrier on level surface
 - Engine stopped (see your -10)
 - Carrier blocked (see your -10)
 - Track shroud and covers removed (WP 0438 00)
 - Road wheel removed (T130) (WP 0426 00)
 - Road wheel removed (T150) (WP 0426 01)
 - Road wheel hub removed (WP 0416 00)
 - Shock absorber removed from second, or fifth road wheel (WP 0435 00)
 - Torsion bar removed (WP 0413 00)
-

REMOVAL

1. Remove six screws (1), road wheel arm housing (2) (number one and two positions) and packing (3).
2. Remove two screws (1), four screws (4), road wheel support arm housing (2), packing (3), and guard (5) from hull (number three position).
3. Remove two screws (1), four screws (4), road wheel support arm housing (2), packing (3), and guard (5) from hull (number four and five positions).

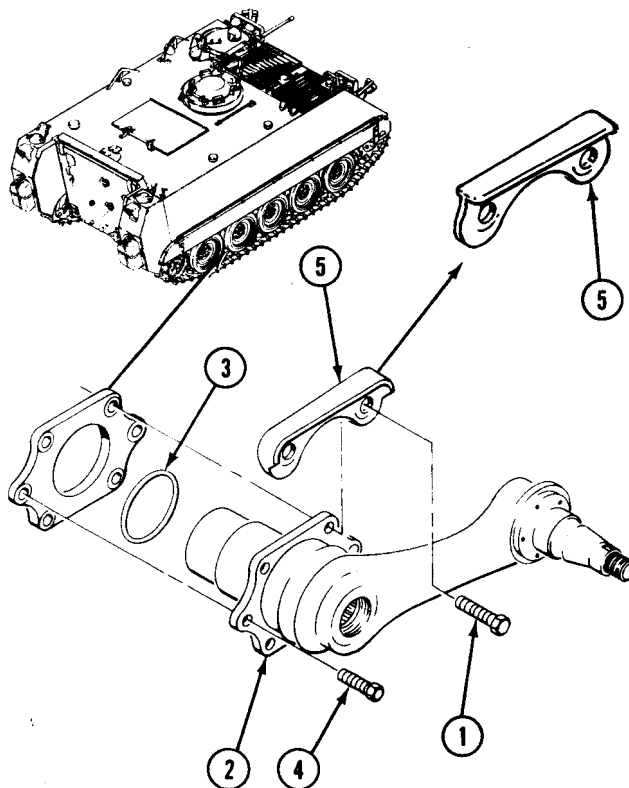

4. Remove six screws (1), three washers (2), seal (3), retainer (4), and gasket (5) from housing (6). Discard washers, seal and gasket.
5. Remove support arm (7), seal (8), and spacer (9) from housing (6). Discard seal.
6. If needed, remove two bearings (10) from housing (6).

7. Remove lubrication fitting (11) and relief valve (12) from support arm (7).

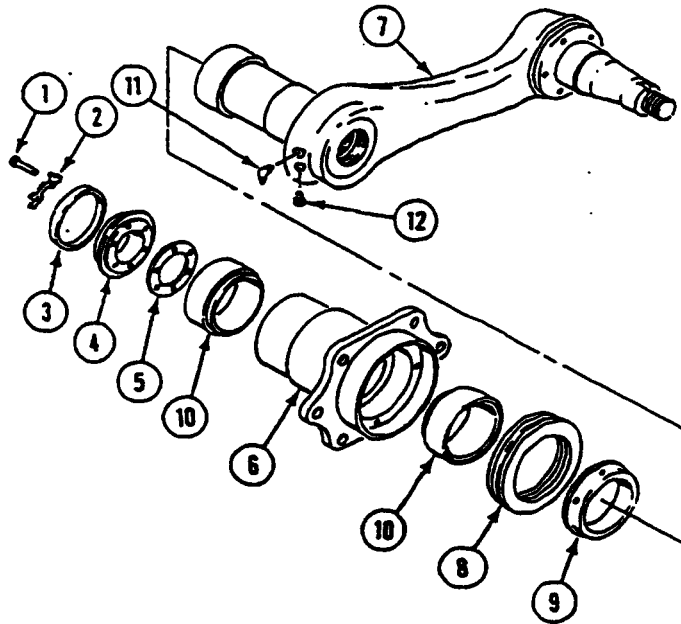

INSTALLATION

NOTE

Make sure shoulders on bearings point toward center of housing.

1. If removed, install two bearings (10) in housing (6). Use replacer.

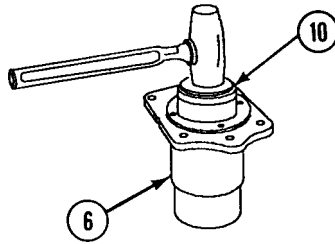
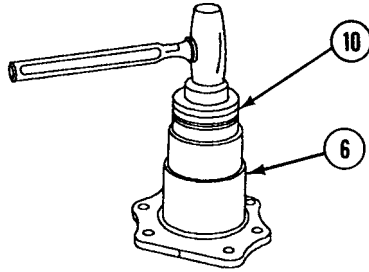

2. Coat threads of relief valve (12) and lubrication fitting (11) with sealing compound. Install valve and fitting in support arm (7).
3. Put light coat of grease on bearing surface of support arm (7) and cork-rubber face of new seal (8). Place spacer (9) and seal, with pins facing housing, on shaft of support arm.
4. Install support arm (7) in housing (6). Align pins on seal (8) with holes in housing.
5. Put light coat of sealing compound on outer surface of new seal (3).
6. Install new gasket (5), retainer (4), and seal (3) in rear of housing (6). Use replacer. Secure with three new washers (2) and six screws (1). Do not tighten screws at this time.
7. Fill support arm housing (6) with grease until grease appears around retainer (4).
8. TIGHTEN SIX SCREWS (1) TO 14-19 LB-FT (19-26 N•m) TORQUE. Bend tabs on new washers (2).

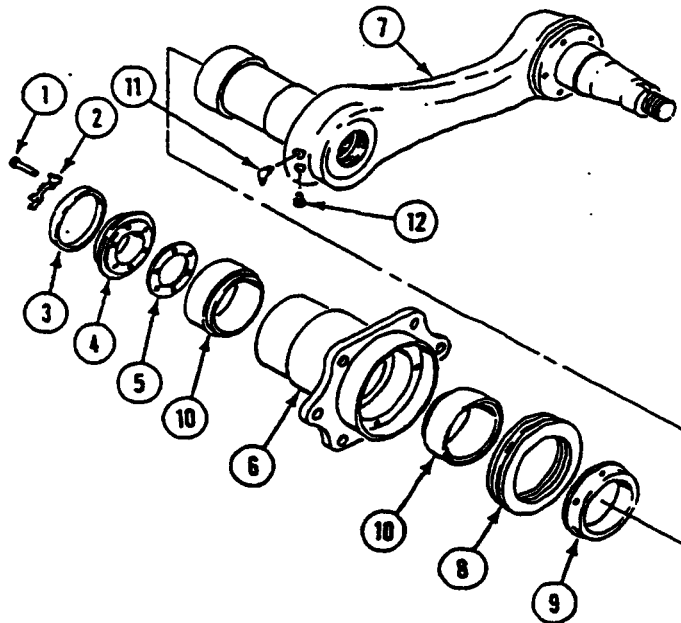

REPLACE ROAD WHEEL SUPPORT ARM, BEARINGS, AND SEALS — Continued**0415 00**

9. Install new packing (1) on housing (2).
10. Secure guard (3), packing (1), and road wheel support arm housing (2) to hull (number four and five positions) with four screws (4) and two screws (5). **TIGHTEN SIX SCREWS TO 130-140 LB-FT (176-190 N•m) TORQUE.**
11. Secure guard (3), packing (1) and road wheel support arm housing (2) to hull (number three position) with four screws (4) and two screws (5). **TIGHTEN SIX SCREWS TO 130-140 LB-FT (176-190 N•m) TORQUE.**
12. Secure assembled road wheel support arm (6) and packing (1) to hull (number one and two positions) with six screws (5). **TIGHTEN SCREWS TO 130-140 LB-FT (176-190 N•m) TORQUE.**

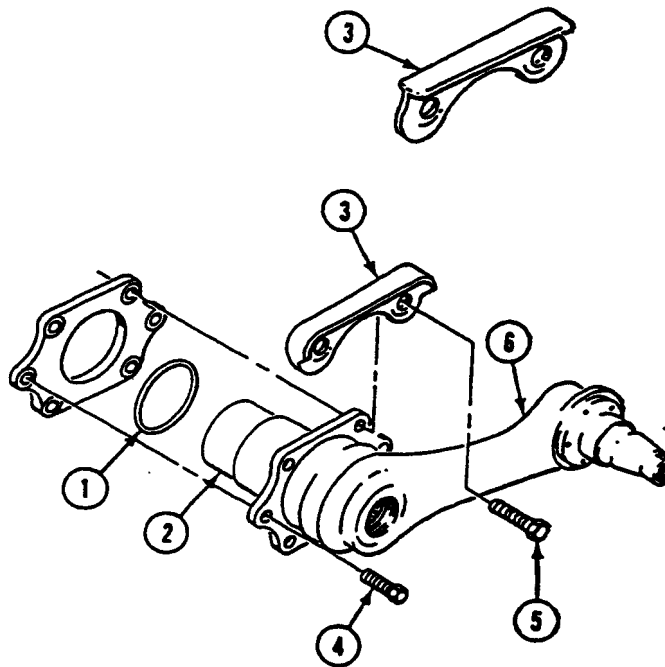
**FOLLOW-THROUGH STEPS**

1. Install torsion bar (WP 0413 00).
2. If removed, install shock absorber (WP 0435 00).
3. Install road wheel hub (WP 0416 00).
4. Install road wheel (T130) (WP 0426 00).
5. Install road wheel (T150) (WP 0426 01).
6. Install track shroud and covers (WP 0438 00).
7. Unblock carrier (see your -10).
8. Road test carrier to check that arm is installed right (WP 0155 00).

END OF TASK

REPLACE ROAD WHEEL HUB

0416 00

THIS WORK PACKAGE COVERS:

- Removal page 0416 00-1.
- Cleaning page 0416 00-2.
- Installation page 0416 00-3.

INITIAL SETUP:

Maintenance Level

Unit

Personnel Required

Unit Mechanic

Tools and Special Tools

- General Mechanic's Tool Kit (WP 0926 00, Item 65)
- Replacer (WP 0926 00, Item 43)
- Ring Spacer (WP 0926 00, Item 56)
- Torque Wrench (WP 0926 00, Item 83)
- Torque Wrench (WP 0926 00, Item 85)

References

- See your -10
- TM 9-214

Materials/Parts

- Grease (WP 0928 00, Item 12)
- Sealing compound (WP 0928 00, Item 50)
- Cotter pin
- Hub cap gasket
- Hub to arm seal
- Inner bearing cup (as needed)
- Inner bearing (as needed)
- Outer bearing cup (as needed)
- Outer bearing (as needed)

Equipment Condition

- Carrier on level surface
- Engine stopped (see your -10)
- Carrier blocked (see your -10)
- Track shroud and covers removed (WP 0438 00)
- Road wheel removed (T130) (WP 0426 00)
- Road wheel removed (T150) (WP 0426 01)

REMOVAL

1. Remove four screws (1), hub cap (2), and gasket (3) from road wheel hub (4). Discard gasket.
2. Remove cotter pin (5), nut (6), washer (7), and hub (4) from road wheel support arm (8). Discard cotter pin.
3. Remove seal (9), outer bearing (10), and inner bearing (11) from hub (4). Discard seal.
4. Remove grease fitting (12) and relief valve (13) from hub (4).
5. If damaged, remove bolt(s) (14) from hub (4). Discard bolt(s).
6. If damaged, remove bearing cups (15) and (16) from hub (4). Discard cups.

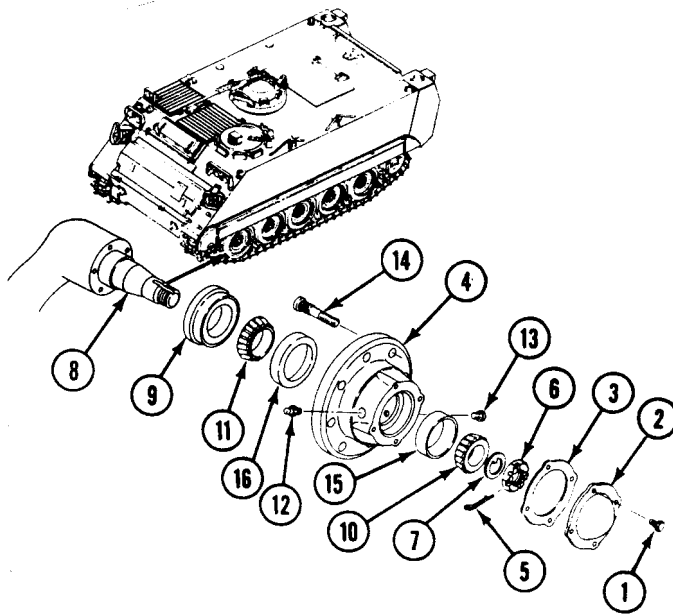
**CLEANING****CAUTION**

Bearings must be replaced as assemblies. Do not mix cups and bearings.

1. Clean and inspect bearings in accordance with TM 9-214. Replace bad bearings and cups.

INSTALLATION

CAUTION

Bearings must be replaced as assemblies. Do not mix cups and bearings.

1. If removed, install new bearing cups (1) and (2) in hub (3). Use replacer.
2. If removed, install new bolts (4) in road wheel hub (3).
3. Apply a light coat of sealing compound to threads of relief valve (5) and lubrication fitting (6). Install valve and fitting in hub (3).
4. Pack inner bearing (7) with grease. Install bearing in rear of hub (3).
5. Apply a light coat of sealing compound to external surface of new seal (8).
6. Install new seal (8) in hub (3) using replacer.
7. Place hub (3) on road wheel support arm (9). Completely pack cavity in hub with grease.
8. Pack outer bearing (10) with grease. Install in hub (3).
9. Install washer (11) and nut (12) on support arm (9). Tighten nut to adjust bearing as follows:
 - a. TIGHTEN NUT (12) TO 140-150 LB-FT (190-203 N·m) TORQUE.
 - b. Back off nut (12) until there is no torque.
 - c. TIGHTEN NUT (12) TO 70-75 LB-FT (95-102 N·m) TORQUE.
 - d. Back off nut to align nearest cotter pin hole in nut with cotter pin in support arm (9).
10. Install new cotter pin (13) in support arm (9).
11. Install new gasket (14), hub cap (15), and four screws (16) in hub (3).
12. Fill hub (3) with grease (WP 0155 00).

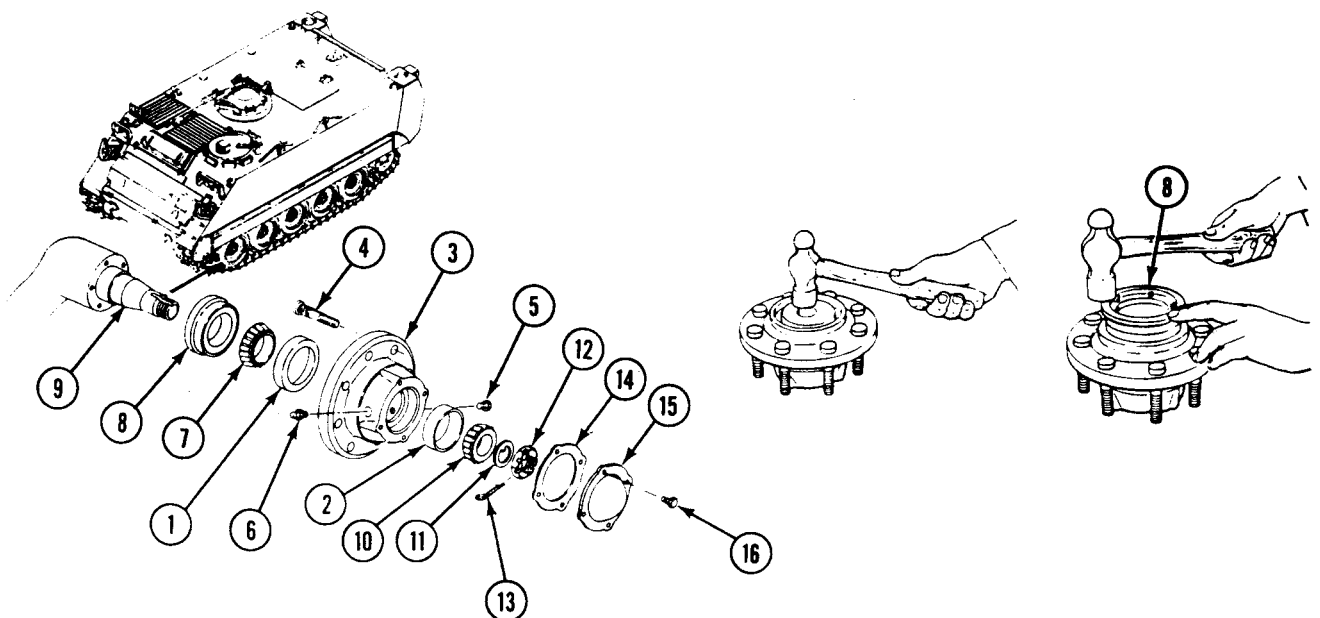

FOLLOW-THROUGH STEPS

1. Install road wheel (T130) (WP 0426 00).
2. Install road wheel (T150) (WP 0426 01).
3. Install track shroud and covers (WP 0438 00).
4. Unblock carrier (see your -10).
5. Road test carrier to check that hub is installed right (WP 0155 00).

END OF TASK

REPLACE IDLER WHEEL ARM ASSEMBLY

0417 00

THIS WORK PACKAGE COVERS:

- Removal (page 0417 00-1).
- Installation (page 0417 00-2).

INITIAL SETUP:

Maintenance Level

Unit

References

See your -10

Tools and Special Tools

- General Mechanic's Tool Kit (WP 0926 00, Item 65)
- Torque Wrench (WP 0926 00, Item 86)

Equipment Condition

- Carrier on level surface
- Engine stopped (see your -10)
- Carrier blocked (see your -10)
- Track shroud and covers removed (WP 0438 00)
- Track disconnected (see your -10)
- Idler wheel removed (WP 0425 00)
- Idler wheel hub removed (WP 0418 00)
- Track tension adjuster disconnected from idler wheel arm (WP 0419 00)

Materials/Parts

- Grease (WP 0928 00, Item 12)
- Sealing compound (WP 0928 00, Item 50)

Personnel Required

Unit Mechanic

REMOVAL

1. Remove eight screws (1) and idler wheel arm (2) from hull.
2. Remove grease fitting (3) and relief valve (4) from idler arm (2).

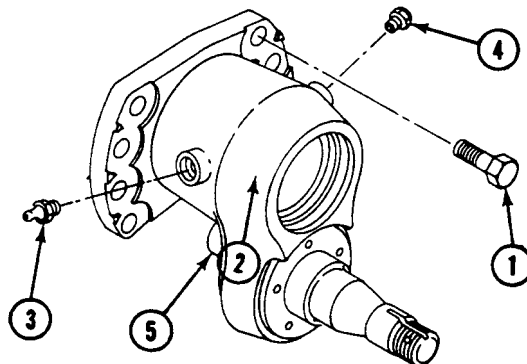
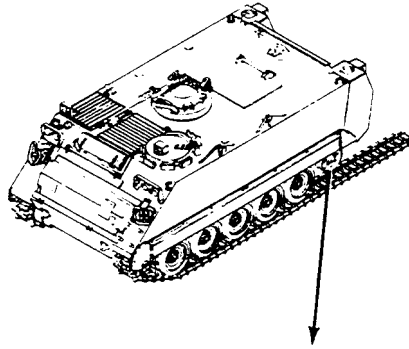

INSTALLATION

1. Apply light coat of sealing compound on threads of relief valve (4) and grease fitting (3).

NOTE

Install grease fitting on the forward side of idler arm.

2. Install relief valve (4) and grease fitting (3) in idler arm (2).
3. Place track tension adjuster (5) on shaft on rear of idler arm (2). Align idler arm with holes on hull. Secure with eight screws (1). Tighten screws to 315-325 lb-ft (427-441 N.m) torque.
4. Fill idler arm (2) with grease (WP 0155 00).

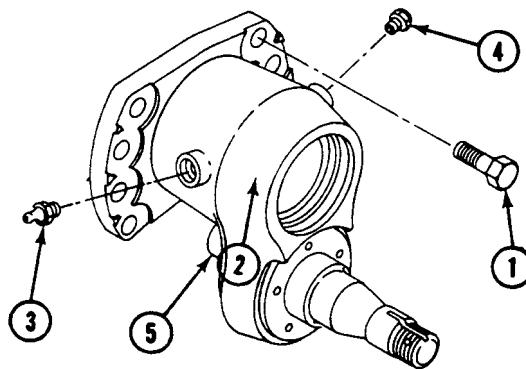
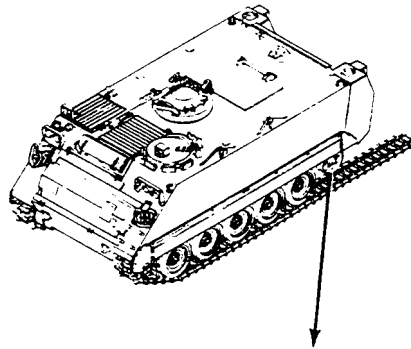
**FOLLOW-THROUGH STEPS**

1. Connect track tension adjuster to idler arm (WP 0419 00).
2. Install idler wheel hub (WP 0418 00).
3. Install idler wheel (WP 0425 00).
4. Connect track and adjust tension (see your -10).
5. Install track shroud and covers (WP 0438 00).
6. Unblock carrier (see your -10).
7. Road test carrier to check that idler wheel arm is installed right (WP 0155 00).

END OF TASK

REPLACE IDLER WHEEL ARM BEARINGS AND SEALS

0418 00

THIS WORK PACKAGE COVERS:

- Removal (page 0418 00-1).
- Cleaning (page 0418 00-2).
- Installation (page 0418 00-2).

INITIAL SETUP:

Maintenance Level

Unit

Personnel Required

Unit Mechanic

Tools and Special Tools

- General Mechanic's Tool Kit (WP 0926 00, Item 65)
- Replacer (WP 0926 00, Item 43)
- Torque Wrench (WP 0926 00, Item 85)

References

- See your -10
- TM 9-214

Materials/Parts

- Grease (WP 0928 00, Item 12)
- Sealing compound (WP 0928 00, Item 50)
- Sealing compound (WP 0928 00, Item 56)
- Cotter pin
- Gasket
- Seal

Equipment Condition

- Carrier on level surface
- Engine stopped (see your -10)
- Carrier blocked (see your -10)
- Track shroud and covers removed (WP 0438 00)
- Track disconnected (see your -10)
- Idler wheel removed (WP 0425 00)

REMOVAL

1. Remove four screws (1), hub cap (2), and gasket (3) from idler wheel hub (4). Discard gasket.
2. Remove cotter pin (5), nut (6), washer (7), and hub (2) from idler wheel arm (8). Discard cotter pin.

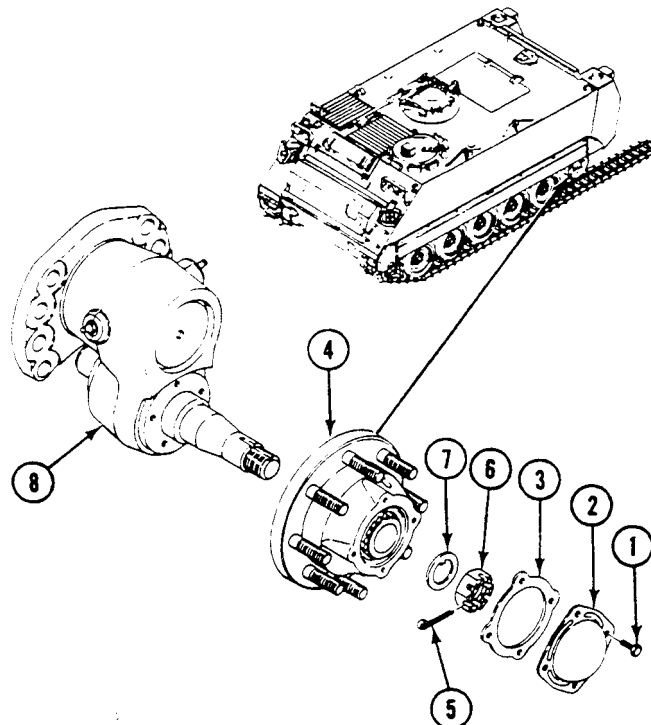

3. Remove seal (1), inner bearing (2), and outer bearing (3) from hub (4). Discard seal.
4. Remove grease fitting (5) and relief valve (6) from hub (4).
5. If damaged, remove bolt(s) (7) from hub (4). Discard damaged bolt(s).
6. If damaged, remove bearing cups (8) and (9) from hub (4).

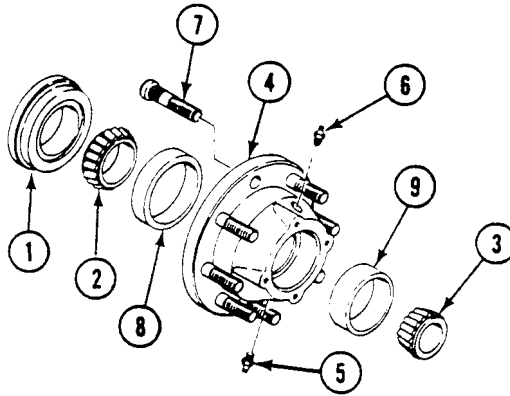

CLEANING

1. Clean and check bearings. See TM 9-214. Replace bad bearings and cups.

INSTALLATION

1. If removed, install bearing cups (10) and (11) in hub (12). Use replacer.

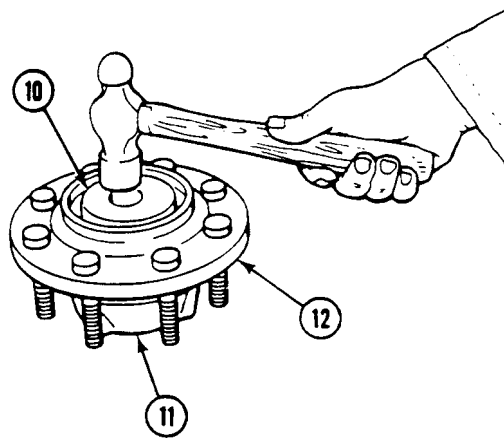

2. If removed, install new bolt(s) (13) in hub (12).
3. Apply light coat of sealing compound to threads of relief valve (14) and grease fitting (15). Install valve and fitting in hub (12).
4. Pack inner bearing (16) with grease. Install bearing in rear of hub (12).
5. Apply light coat of sealing compound to outer surface of new seal (17).

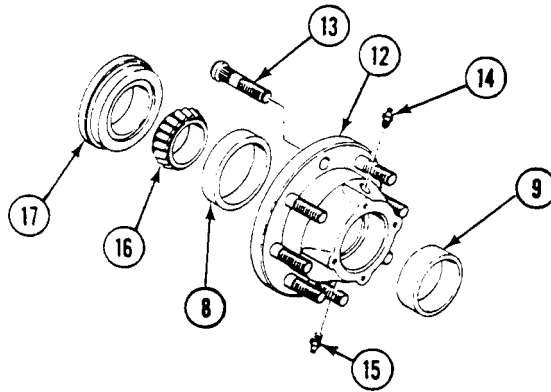

6. Install seal (17) in hub (12). Use replacer.

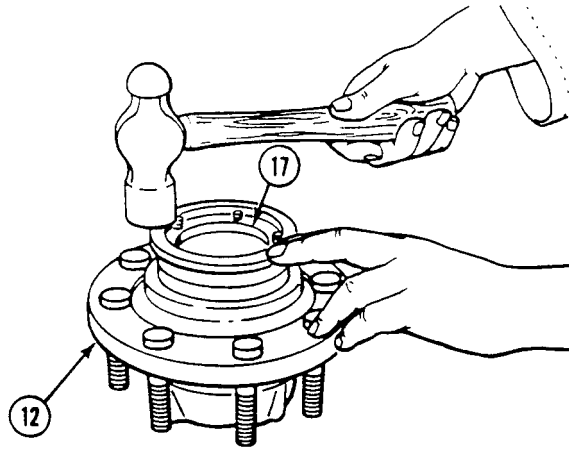

7. Place hub (1) on idler wheel arm (2). Completely pack cavity in hub with grease.
8. Pack outer bearing (3) with grease. Install bearing in hub (1).
9. Install washer (4) and nut (5) on arm (2). Tighten nut to adjust bearings as follows:

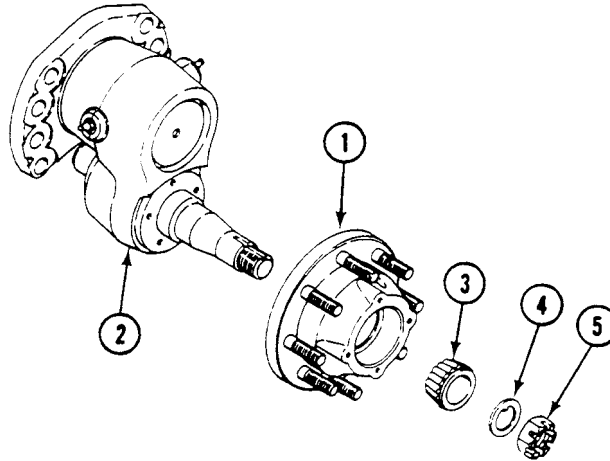

- a. TIGHTEN NUT (5) TO 140-150 LB-FT (190-203 N·m) TORQUE.
 - b. Back off nut (5) until there is no torque.
 - c. TIGHTEN NUT (5) TO 70-75 LB-FT (95-102 N·m) TORQUE.
 - d. Back off nut (5) to align nearest cotter pin hole in nut with cotter pin hole in arm (2).
10. Install new cotter pin (6) in arm (7).
 11. Install new gasket (8), hub cap (9), and four screws (10) in hub (1).
 12. Fill hub (1) with grease (WP 0155 00).

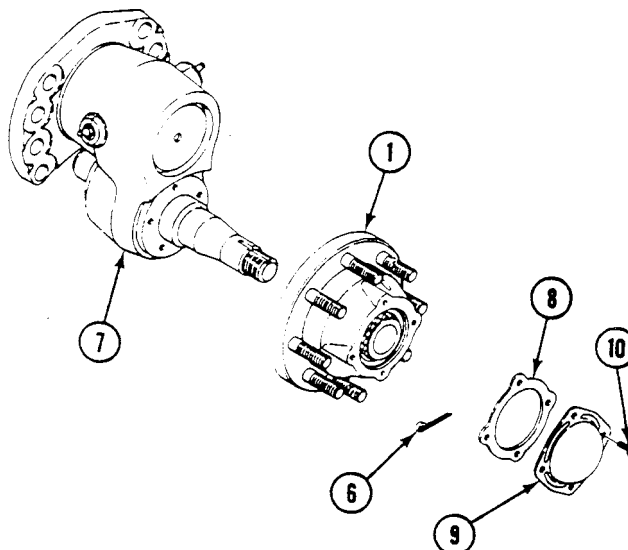

FOLLOW-THROUGH STEPS

1. Install idler wheel (WP 0425 00).
2. Connect track and adjust tension (see your -10).
3. Install track shroud and covers (WP 0438 00).
4. Unblock carrier (see your -10).
5. Road test carrier to check that idler wheel hub is installed right (WP 0155 00).

END OF TASK

REPLACE TRACK TENSION ADJUSTER AND MOUNT

0419 00

THIS WORK PACKAGE COVERS:

Removal (page 0419 00-1).
 Installation (page 0419 00-3).

INITIAL SETUP:

Maintenance Level

Unit

References

See your -10

Tools and Special Tools

General Mechanic's Tool Kit (WP 0926 00, Item 65)
 Torque wrench adapter (WP 0926 00, Item 4)
 Torque wrench (WP 0926 00, Item 85)

Equipment Condition

Carrier on level surface
 Engine stopped (see your -10)
 Carrier blocked (see your -10)
 Track shroud and covers removed (WP 0438 00)
 Track disconnected (see your -10)

Personnel Required

Unit Mechanic

REMOVAL

1. Remove screw (1) and washer (2) from mount (3).

REPLACE TRACK TENSION ADJUSTER AND MOUNT — Continued

0419 00

2. Remove screw (4) and washer (5) from shaft on idler arm.
3. Remove two screws (6) from mount (3). Loosen screw (7). Rotate mount and remove screw (7).
4. Pull track adjuster (8) down. Remove mount (3) from adjuster.
5. Remove adjuster (8) from shaft on idler arm.
6. Remove grease fitting (9) and relief valve (10) from adjuster (8).

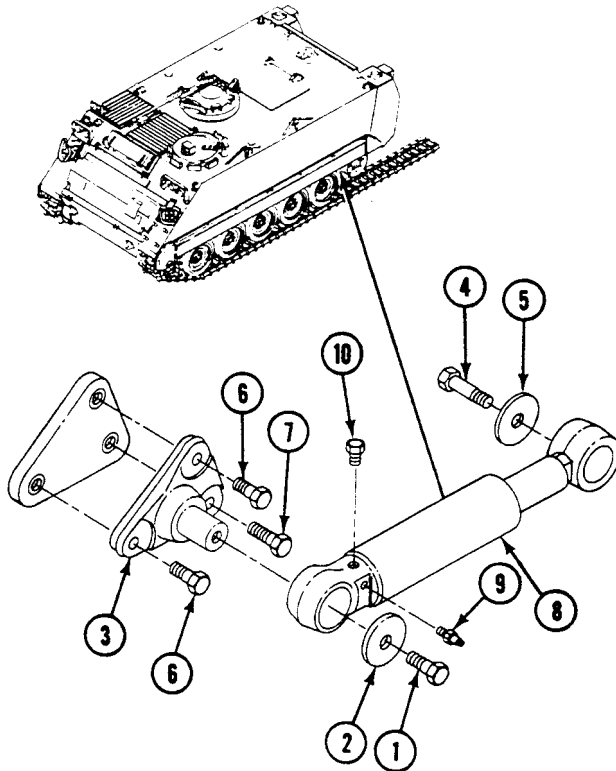

INSTALLATION

NOTE

Grease fitting and relief valve of track tension adjuster should be toward front of carrier. Make sure grease fitting is pointing out.

1. Install relief valve (1) and grease fitting (2) in track tension adjuster (3).
2. Place track adjuster (3) on shaft of idler arm.
3. Install mount (4) in front of adjuster (3). Raise adjuster and mount. Align hole in mount with hole in hull for screw (5).
4. Install screw (5) in mount (4). Tighten until snug.

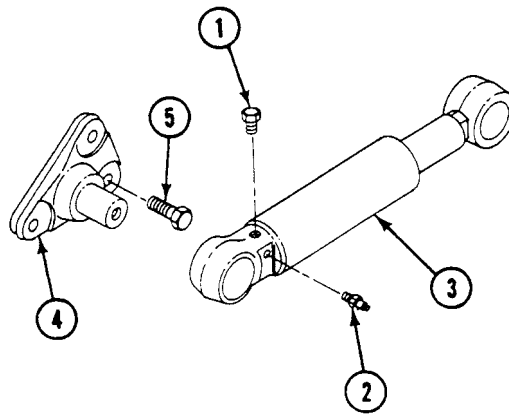

5. Rotate mount (4). Install two screws (6).

NOTE

**When using torque wrench with torque wrench adapter, torque value must be corrected.
Procedure for converting torque value is on (WP 0155 00).**

6. TIGHTEN SCREW (5) AND TWO SCREWS (6) TO 130-140 LB-FT (176-190 N·m) TORQUE.
7. Install washer (7) and screw (8) in shaft idler arm. TIGHTEN SCREW TO 130-140 LB-FT (176-190 N·m) TORQUE.
8. Install washer (9) and screw (10) on mount (4). TIGHTEN SCREW TO 130-140 LB-FT (176-190 N·m) TORQUE.

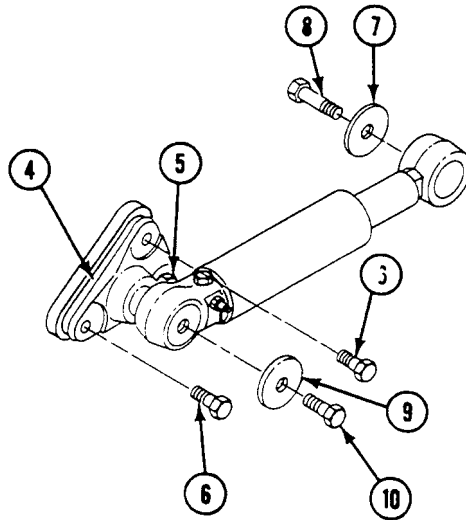

FOLLOW-THROUGH STEPS

1. Connect and adjust track (see your -10).
2. Install track shroud and covers (WP 0438 00).
3. Unblock carrier (see your -10).
4. Road test carrier to check that adjuster is installed right (WP 0155 00).

END OF TASK

REVERSE T150 TRACK DRIVE SPROCKET AND TRACK ASSEMBLIES**0419 01****THIS WORK PACKAGE COVERS:**

Removal (page 0419 01-1)

Installation (page 0419 01-2)

INITIAL SETUP:Maintenance Level

Unit

Tools and Special Tools

General Mechanic's Tool Kit (WP 0426 00, Item 65)

Socket Wrench (WP 0926 00, Item 73)

Wrench, Torque (WP 0926 00, Item 86)

Materials/Parts

Self-locking screws (10)

Personnel Required

Unit Mechanic

Helper (H)

References

See your -10

Equipment Conditions

Vehicle on level surface

Engine stopped (see your -10)

Vehicle unblocked (see your -10)

Track disconnected (see your -10)

Vehicle driven completely off tracks (see your -10)

REMOVAL**WARNING**

Hanging loads, heavy parts, and overhead equipment can fall unexpectedly. Falling loads can kill or seriously injure personnel.

Keep away from hanging loads, heavy parts, and overhead equipment. Use correct lifting devices to move hanging loads and heavy parts. Always have a helper guide you. Keep hands and feet out of confined spaces from which heavy loads are being installed or removed.

1. Remove 10 screws (3) and carrier (1) from final drive (2). Lower carrier to the ground. Repeat for other side of vehicle. Have helper assist.

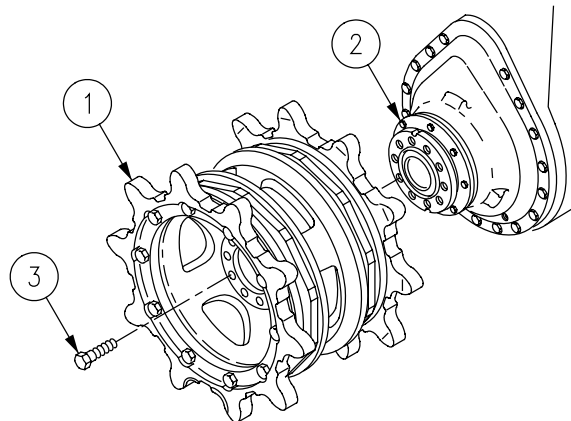

WARNING

Hanging loads, heavy parts, and overhead equipment can fall unexpectedly. Falling loads can kill or seriously injure personnel

Keep away from hanging loads, heavy parts, and overhead equipment. Use correct lifting devices to move hanging loads and heavy parts. Always have a helper guide you. Keep hands and feet out of confined spaces from which heavy loads are being installed or removed.

INSTALLATION

1. Move carrier (1) to opposite side of vehicle. Install on final drive (2). Secure with 10 screws (3). Repeat for other side of vehicle. Have helper assist.
2. **TIGHTEN 10 SCREWS (3) TO 170-190 LB-FT (231-258 N·m) TORQUE.**

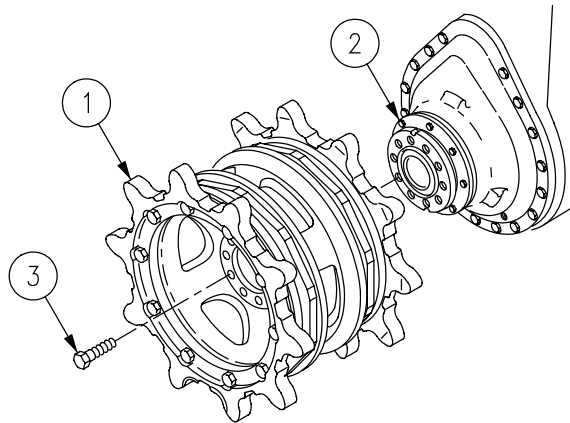

3. Reverse track direction. Use towing vehicle (see your -10).
4. Align tracks in front of vehicle. Tow disabled vehicle onto tracks. Use towing vehicle (see your-10).
5. Install tracks (8) on vehicle.

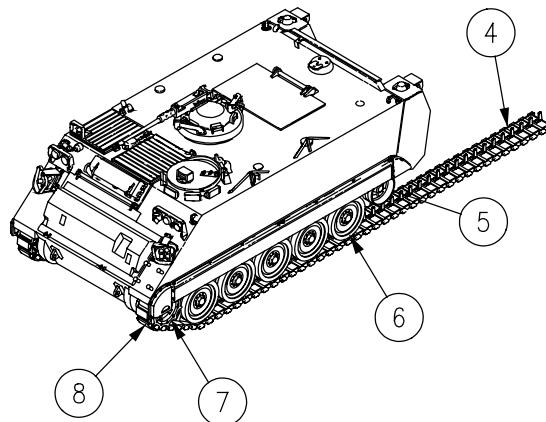

- a. (H): Notify driver in tow vehicle to stop when seven track shoes (4) have passed the fifth road wheel (6). Using a crowbar, position track (8) on sprockets (7). Notify driver to start vehicle engine and slowly drive forward.
- b. (H): Use crowbar to guide track (8) until over idler wheels (5). Notify driver to stop when three track shoes (4) remain before set of road wheels (6).

FOLLOW-THROUGH STEPS

1. Join track (see your -10).
2. TIGHTEN TWO END CONNECTOR BOLTS (1) TO 400-430 LB-FT (529-579 N·m) TORQUE.

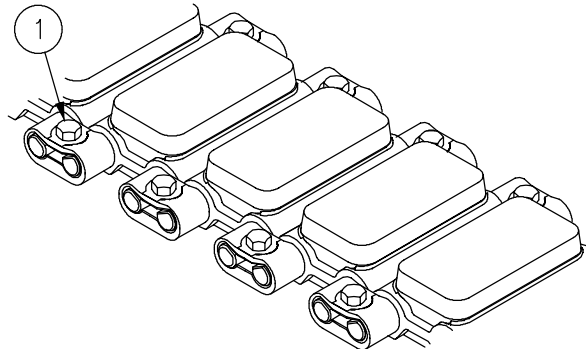

3. Adjust track tension (see your -10).
4. Unblock vehicle (see your -10).
5. Road test carrier to check that drive sprocket and carrier assembly are installed correct (see your -10).

END OF TASK

REPLACE T130 DRIVE SPROCKET AND WHEEL ASSEMBLY

0420 00

THIS WORK PACKAGE COVERS:

- Removal (page 0420 00-1).
- Installation (page 0420 00-2).

INITIAL SETUP:

Maintenance Level

Unit

References

See your -10

Tools and Special Tools

- General Mechanic's Tool Kit (WP 0926 00, Item 65)
- Socket Wrench Set (WP 0926 00, Item 73)
- Torque Wrench (WP 0926 00, Item 86)

Equipment Condition

- Carrier on level surface
- Engine stopped (see your -10)
- Carrier blocked (see your -10)
- Track shroud and covers removed (WP 0438 00)
- Track disconnected (see your -10)

Materials/Parts

- Self-locking screws (10)

Personnel Required

Unit Mechanic

REMOVAL

1. Remove track from drive sprocket wheel assembly (1).
2. Remove 10 self-locking screws (2) and sprocket wheel assembly (1) from final drive (3). Discard self-locking screws.

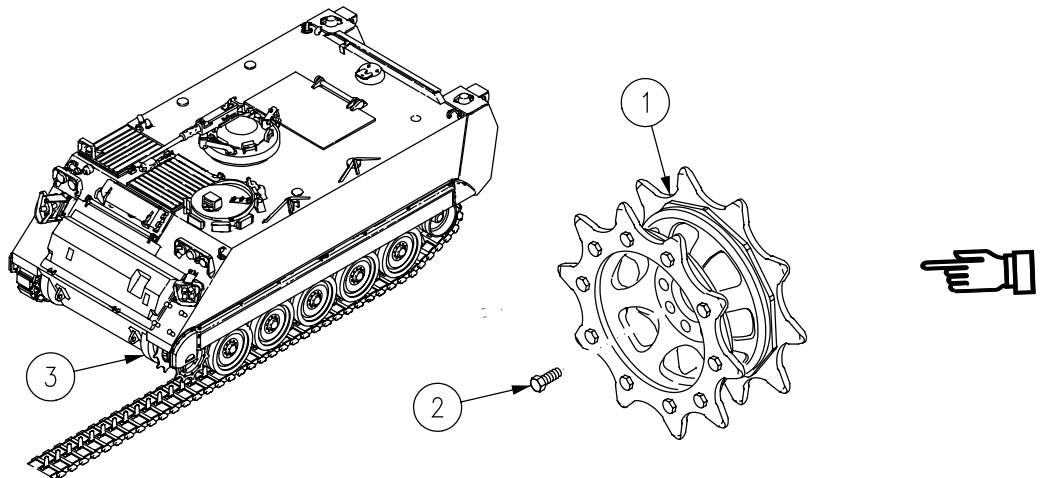

INSTALLATION

1. Place drive sprocket wheel assembly (1) on final drive (3). Secure with 10 new self-locking screws (2).
TIGHTEN SCREWS TO 170-190 LB-FT (231-258 N.m) TORQUE.
2. Place track on drive sprocket wheel assemblies (1).

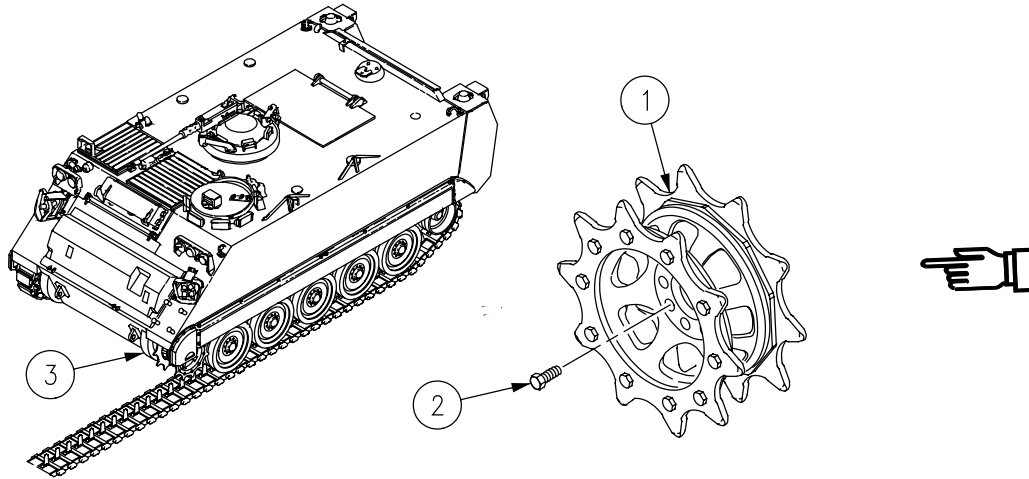
**FOLLOW-THROUGH STEPS**

1. Connect track and adjust tension (see your -10).
2. Install track shroud and covers (WP 0438 00).
3. Unblock carrier (see your -10).
4. Road test carrier to check that drive sprocket wheel assembly is installed right (WP 0155 00).

END OF TASK

REPAIR T150 DRIVE SPROCKET WHEEL ASSEMBLY

0420 01

THIS WORK PACKAGE COVERS:

- Removal (page 0420 01-1)
- Installation (page 0420 01-2)

INITIAL SETUP:

Maintenance Level

Unit

Tools and Special Tools

- General Mechanic's Tool Kit (WP 0926, Item 65)
- Socket Wrench (WP 0926 00, Item 73)
- Torque Wrench (WP 0926 00, Item 85)
- Torque Wrench (WP 0926 00, Item 86)

Materials/Parts

- Self-locking screws (10)
- Self-locking screws (20)

Personnel Required

- Unit Mechanic (M)
- Helper (H)

References

See your -10

Equipment Conditions

- Engine stopped (see your -10)
- Vehicle blocked (see your -10)
- Track broken between sprocket or fifth road wheel (see your -10)
- Track removed from drive sprocket (WP 0422 01)

REMOVAL

NOTE

Procedures for repairing left and right sprocket wheel assemblies are the same.

1. Remove 10 self-locking screws (3) and sprocket wheel assembly (2) from final drive (1). Lower sprocket wheel assembly to the ground. Have helper assist. Discard self-locking screws.

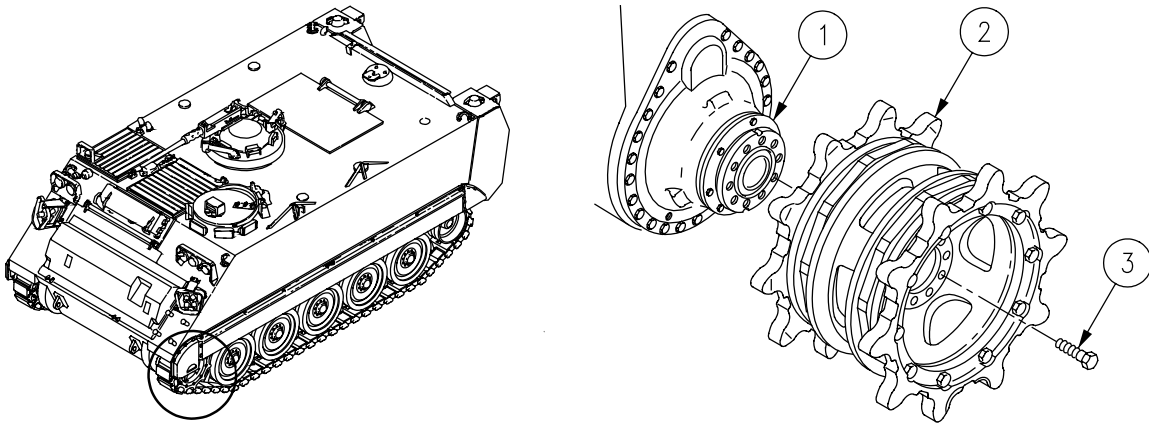

REPAIR T150 DRIVE SPROCKET WHEEL ASSEMBLY - Continued

0420 01

2. Remove 20 self-locking screws (4), two drive sprockets (5), and rings (6) from sprocket wheel (8). Discard self-locking screws.
3. Remove two rubber cushions (7) from sprocket wheel (8).

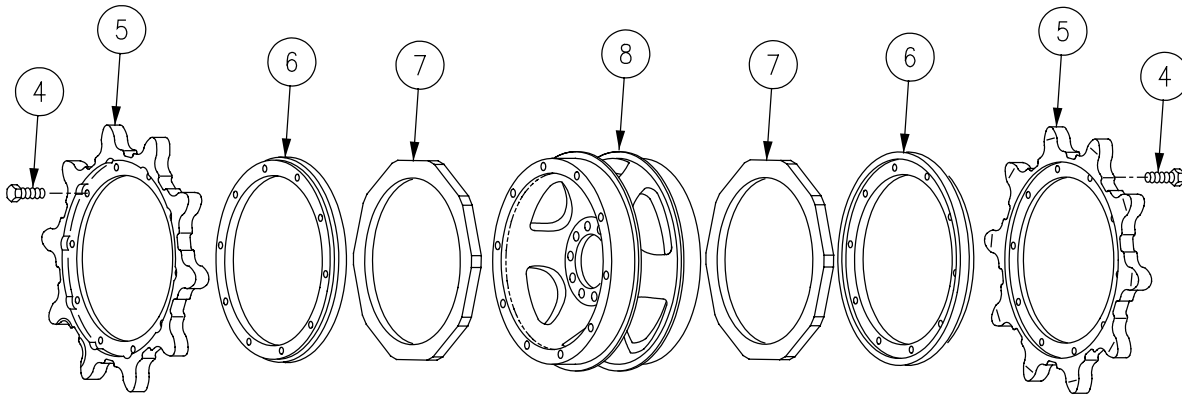

INSTALLATION

NOTE

Procedures for repairing left and right sprocket wheels are the same.

1. Place two rubber cushions (7) on sprocket wheel (8). Center short flange at least between mounting holes in sprocket wheel rim. Press on rubber cushions until firmly seated against flange of carriers.
2. Install two rings (6), two sprockets (5), and 20 new self-locking screws (4) on sprocket wheel (8).
3. TIGHTEN 20 SCREWS (1) TO 10 FT-LB (149 N-m) TORQUE

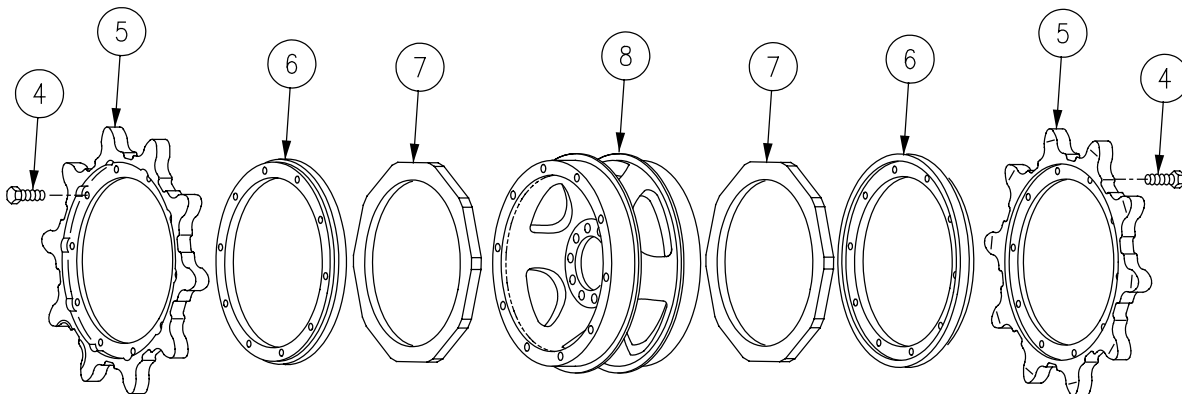

4. Place sprocket wheel assembly (2) on final drive (1). Secure with 10 new self-locking screws (3). Have helper assist.

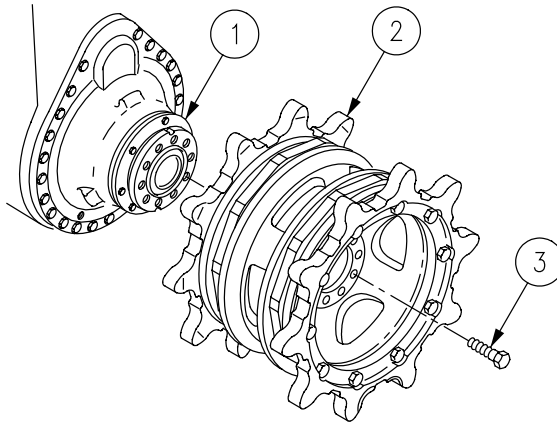

5. TIGHTEN 10 SCREWS (3) TO 70-90 LB-FT (231-258 N·m) TORQUE

FOLLOW-THROUGH STEPS

1. Install track on drive sprockets (WP 0422 00).
2. Join track (see your-10).

3. TIGHTEN TWO END CONNECTOR BOLTS (9) TO 400-430 LB-FT (543-583 N·m) TORQUE

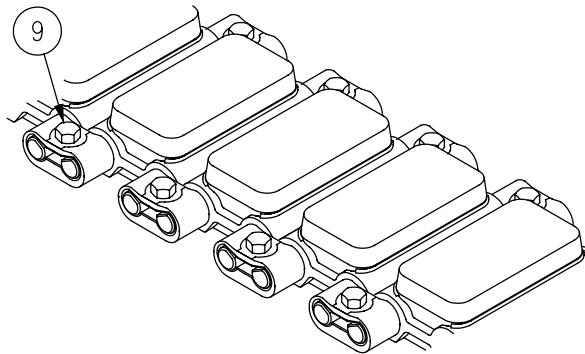

4. Adjust track tension (see your-10).
5. Road test vehicle to check that drive sprocket and cushion are installed right (see your -10).

END OF TASK

REPAIR T130 DRIVE SPROCKET WHEEL ASSEMBLY

0421 00

THIS WORK PACKAGE COVERS:

Removal (page 0421 00-1).
 Installation (page 0421 00-2).

INITIAL SETUP:

Maintenance Level

Unit

References

See your -10

Tools and Special Tools

General Mechanic's Tool Kit (WP 0926 00, Item 65)
 Torque Wrench (WP 0926 00, Item 85)

Equipment Condition

Carrier on level surface
 Engine stopped (see your -10)
 Carrier blocked (see your -10)
 Track shroud and covers removed (WP 0438 00)
 Track disconnected (see your -10)
 Drive sprocket wheel assembly removed
 (WP 0420 00)

Materials/Parts

Self-locking bolt (20)

Personnel Required

Unit Mechanic

REMOVAL

NOTE

The following maintenance procedure applies to one sprocket wheel assembly only.

1. Remove 20 self-locking bolts (1) and two sprockets (2) from sprocket wheel (3). Discard bolts.
2. Remove two rubber cushions (4) from sprocket wheel (3).

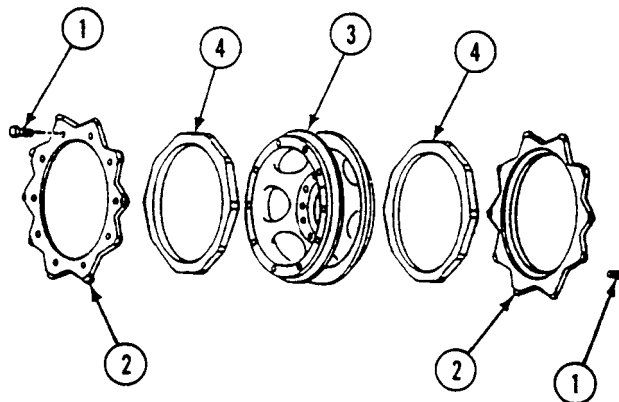

INSTALLATION

NOTE

Make sure you use matching sprockets. New longer life sprockets are thicker and have one wear indicator on both sides of the sprocket teeth. Use as a set when replacing them on a sprocket wheel.

1. Place two cushions (4) on sprocket wheel (3). Center short flat areas between mounting holes in sprocket wheel rim. Press on cushion until firmly seated against flange of sprocket wheel.
2. Place two sprockets (2) on sprocket wheel (3). Secure with 20 new self-locking bolts (1). **TIGHTEN BOLTS TO 110-115 LB-FT (149-156 N•m) TORQUE.**
3. Mark sprockets (2) and cushions (4) for rotation check after road test.

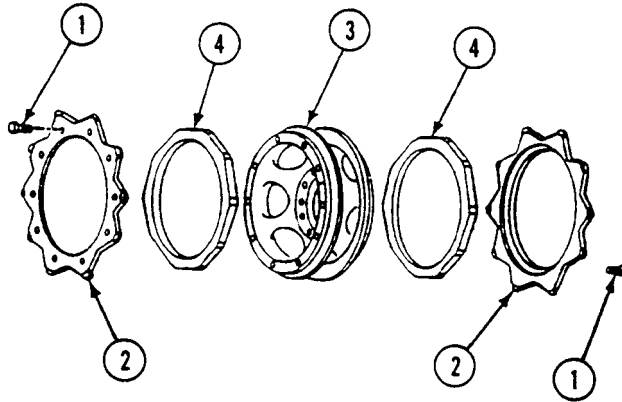

FOLLOW-THROUGH STEPS

1. Install drive sprocket wheel assembly (WP 0420 00).
2. Connect track and adjust tension (see your -10).
3. Install track shroud and covers (WP 0438 00).
4. Unblock carrier (see your -10).
5. Road test carrier to check that drive sprocket wheel assembly and cushion are installed right (WP 0155 00).
6. After road test, check rotation of cushion with respect to sprockets. Measure from the outer edge of the cushion. Replace cushion that rotates beyond 1 1/2 inches (4 cm) of initial position.

CUSHION

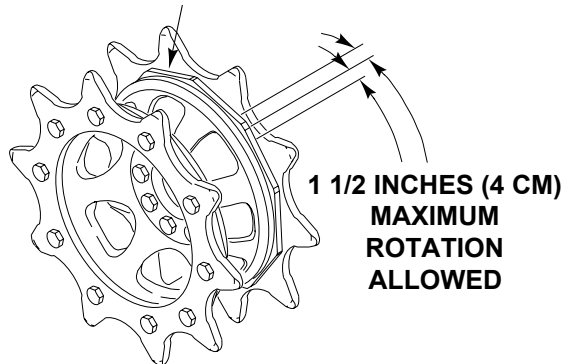

END OF TASK

REPLACE T130 TRACK

0422 00 ■

THIS WORK PACKAGE COVERS:

- Removal (page 0422 00-1).
 - Cleaning, Inspection, and Repair (page 0422 00-2).
 - Installation (page 0422 00-3).
-

INITIAL SETUP:

Maintenance Level

Unit

Personnel Required

Unit Mechanic
Helper (H)

Tools and Special Tools

- General Mechanic's Tool Kit (WP 0926 00, Item 65)
- Track Fixture (2) (WP 0926 00, Item 22)
- Track and Sprocket Gage (WP 0926 00, Item 24)
- Drive Pin Punch (WP 0926 00, Item 40)
- Torque Wrench (WP 0926 00, Item 84)

References

See your -10
TM 9-2530-200-24

Equipment Condition

Engine stopped (see your -10)
Carrier blocked (see your -10)
Track shroud and covers removed (WP 0438 00)

REMOVAL

1. Relieve tension and break track (see your -10).
2. Unblock carrier (see your -10).
3. Start engine (see your -10). Place range selector in R. Slowly back carrier.

4. (H) Guide track (1) over drive sprockets (2), road wheels (3), and idler wheel (4).
5. After carrier clears track (1), set parking brake. Place range selector in SL. Stop engine (see your -10).

WARNING



Failure to set the parking brake and block the road wheels can allow the carrier to move and could result in injury or death. Always set the parking brake and block road wheels before working on the carrier.

6. Block carrier (see your -10).

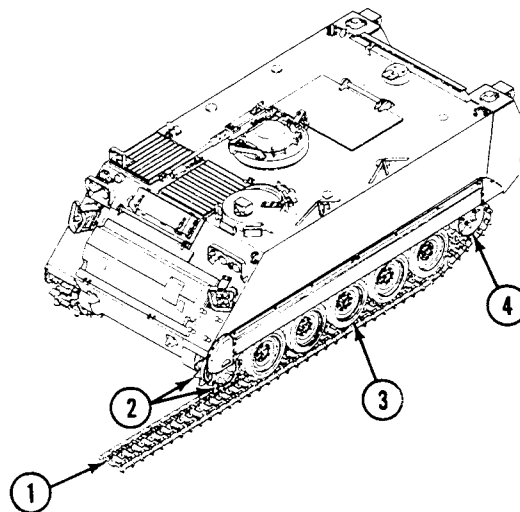
CLEANING, INSPECTION, AND REPAIR

WARNING

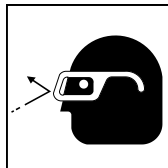

Your eyes can be injured with pressurized water and dirt particles. Wear safety goggles.

1. Clean track with pressurized water.
2. Check track shoes and pads. Replace worn shoes or pads (WP 0423 00) or (WP 0424 00).
3. Check general condition of track. See TM 9-2530-200-24.

INSTALLATION

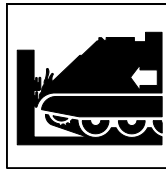
WARNING

Before adjusting the track, ensure there are 63 track shoes on the left side track and 64 track shoes on the right side track. Improper number of shoes may prevent the track from being properly adjusted, creating a safety hazard.

1. (H) Lay track (1) out flat in front of carrier so that track guides are aligned between first pair of road wheels (2).
2. Unblock carrier (see your -10).
3. Start engine (see your -10). Place range selector in 1 drive. Slowly drive carrier forward (see your -10).
4. (H) Pull track (1) up and over idler wheel (3), road wheels (2), and drive sprocket (4).
5. Stop carrier when hub of first road wheel is directly over third track shoe from the end of the track.
6. Place range selector in SL. Stop engine (see your -10).

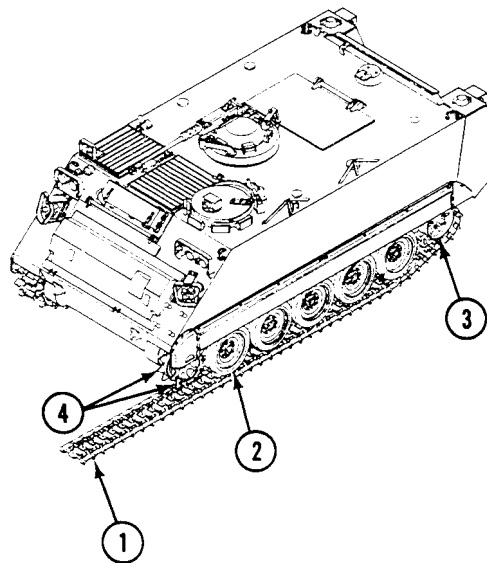

WARNING

Failure to set the parking brake and block the road wheels can allow the carrier to move and could result in injury or death. Always set the parking brake and block road wheels before working on the carrier.

7. Block carrier (see your -10).
8. Join track (see your -10). TIGHTEN TWO NUTS (5) ON TRACK PIN (6) TO 115-135 LB-FT (155-183 N·m) TORQUE.
9. Adjust track tension (see your -10).

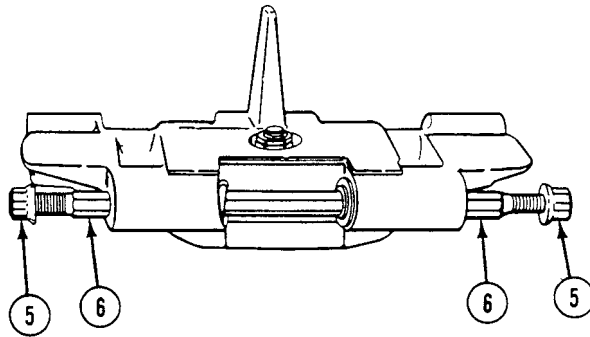
**FOLLOW-THROUGH STEPS**

1. Install track shroud and cover (WP 0438 00).
2. Unblock carrier (see your -10).
3. Road test carrier to check that track is installed right (WP 0155 00).

END OF TASK

REPLACE T150 TRACK

0422 01**THIS WORK PACKAGE COVERS:**

Removal (page 0422 01-1)

Installation (page 0422 01-2)

INITIAL SETUP:Maintenance Level

Unit

References

See your -10

Tools and Special Tools

General Mechanic's Tool Kit (WP 0926 00, Item 65)

Socket Wrench (WP 0926 00, Item 73)

Torque Wrench (WP 0926 00, Item 86)

Tool, Track Pin Alignment (WP 0926 00, Item 67A)

Equipment Conditions

Engine stopped (see your -10)

Vehicle blocked (see your -10)

Track shroud and covers removed (WP 0438 00)

Personnel Required

Unit Mechanic

Helper (H)

REMOVAL**NOTE****The procedure for replacing left and right track assemblies is the same.**

1. Break track (see your-10).
2. Unblock vehicle (see your -10).
3. Drive vehicle off one side of track (see your -10).
4. Block vehicle (see your-10).

INSTALLATION

NOTE

A complete track assembly consists of 63 track shoes on the left side and 64 track shoes on the right side. A flat, level surface about 50 feet long is needed to assemble track sections.

1. Position track shoe assemblies (1) in a line in front of the vehicle. Align track guides of track shoe assemblies between first pair of road wheels.

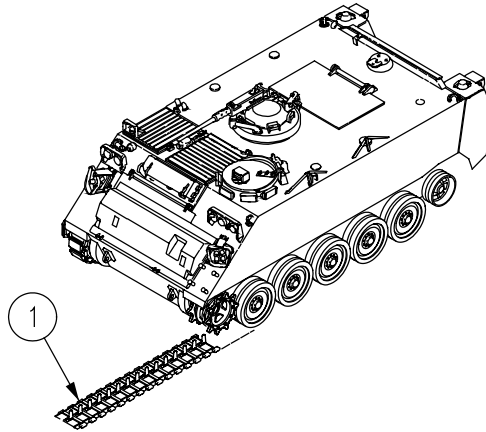

2. Remove non-mating end connectors (2) from each track shoe assembly (1).
3. Position track shoe assemblies (1) so that connecting track shoes are approximately 2 inches off the ground.
4. Connect track shoe assemblies (1).
 - a. Install two track pin alignment tools (4) over track shoe pins (5).
 - b. Install two end connectors (2) on track shoe pins (5). Remove track pin alignment tool (4) before driving end connectors flush with pin ends.
 - c. Drive end connectors (2) flush with pin ends and install bolts (3) on each end connector.

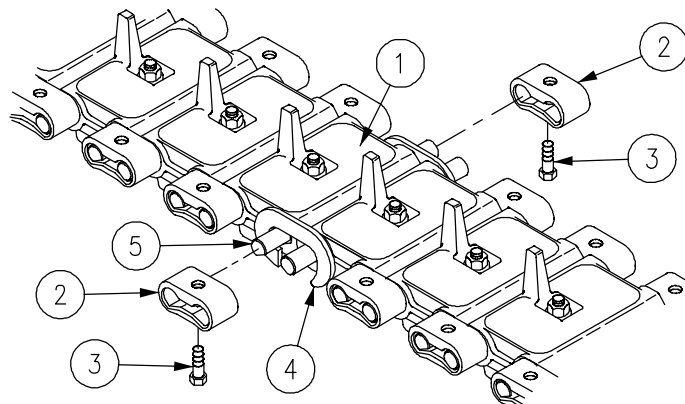

5. Repeat step 4 until a complete track has been connected in a line.
6. Unblock vehicle (see your-10).
7. (H): Drive vehicle forward until track (4) positions on sprockets (5).

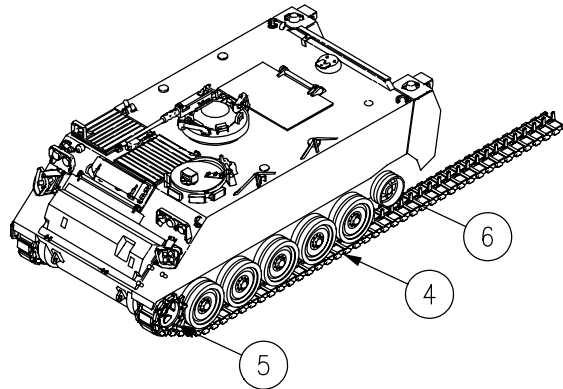

8. (H): Drive vehicle forward until track (4) is over idler wheels (6).
9. Join track (see your -10).
10. TIGHTEN ALL END CONNECTOR BOLTS (3) TO 400-430 LB-FT (543-583 N•m) TORQUE.
11. Adjust track tension (see your-10).

FOLLOW-THROUGH STEPS

1. Unblock vehicle (see your -10).
2. Road test vehicle to check that track is installed correctly (see your -10).
3. Install track shroud and covers (WP 0438 00).

END OF TASK

REPLACE T130 TRACK SHOE ASSEMBLY

0423 00 ■

THIS WORK PACKAGE COVERS:

Repair or replacement (page 0423 00-1).

INITIAL SETUP:

Maintenance Level

Unit

References

See your -10

Tools and Special Tools

General Mechanic's Tool Kit (WP 0926 00, Item 65)
Torque Wrench (WP 0926 00, Item 85)

Equipment Condition

Carrier on level ground
Engine stopped (see your -10)
Carrier blocked (see your -10)

Personnel Required

Unit Mechanic

REPAIR OR REPLACEMENT

1. See your -10 for instructions on replacing the track shoe.
2. TIGHTEN TWO NUTS (1) ON TRACK SHOE PIN (2) TO 115-135 LB-FT (155-183 N·m) TORQUE.

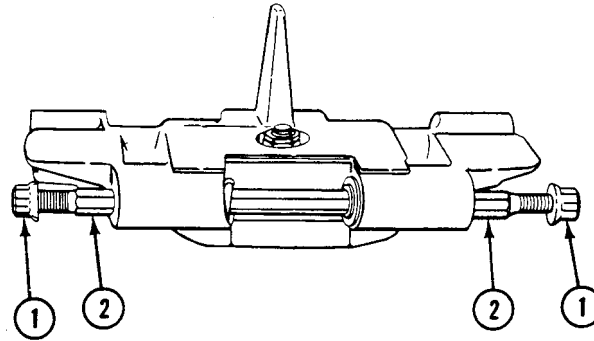

END OF TASK

REPLACE T150 TRACK SHOE ASSEMBLY

0423 01

THIS WORK PACKAGE COVERS:

Removal (page 0423 01-1)

Installation (page 0423 01-2)

INITIAL SETUP:

Maintenance Level

Unit

Tools and Special Tools

General Mechanic's Tool Kit (WP 0926, Item 65)

Socket Wrench (WP 0926 00, Item 73)

Torque Wrench (WP 0926 00, Item 86)

Tool, Track Pin Alignment (WP 0926 00, 67A)

Personnel Required

Unit Mechanic

Helper (H)

References

See your -10

Equipment Conditions

Drive vehicle (see your -10). Move vehicle to reach damaged track shoe. Have helper guide you.

Stop vehicle (see your -10).

Block vehicle (see your -10).

Break track (see your -10).

REMOVAL

NOTE

Track shoes should be removed between drive sprocket and first road wheel or idler wheel and the fifth road wheel.

1. Remove four bolts (3), end connectors (2), and track shoe (1) from track.
2. Remove end connectors (2) from new track.

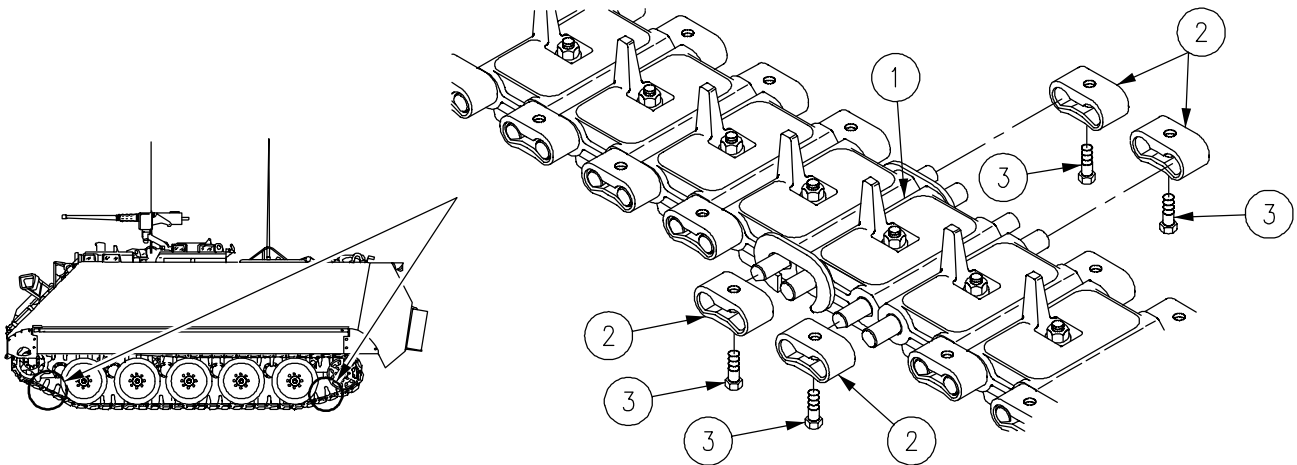

INSTALLATION**NOTE**

Position track shoes at a slight angle to mount end connectors on both pins.

1. Install track shoe (1) on track. Have helper assist.
 - a. Install two track pin alignment tools (4) over track shoe pins (5).
 - b. Install four end connectors (2) on track shoe pins (5). Remove track pin alignment tool (4) before driving end connectors flush with pin ends.
 - c. Drive end connectors (2) flush with pin ends and install bolts (3) on each end connector.
2. Join track (see your-10).
3. **TIGHTEN FOUR BOLTS (3) TO 400-430 LB-FT (543-583 N·m) TORQUE.**

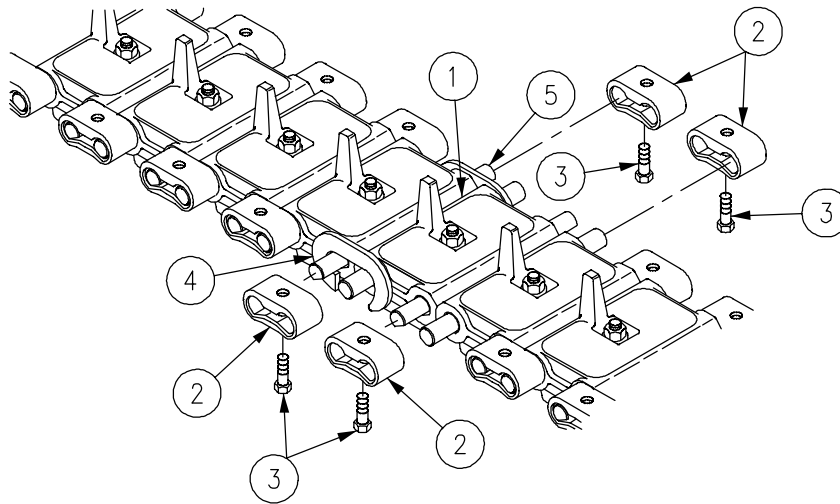
**FOLLOW-THROUGH STEPS**

1. Adjust track tension (see your -10).
2. Unblock vehicle (see your -10).
3. Road test vehicle to check that track is installed right (see your -10).

END OF TASK

REPLACE T130 TRACK SHOE PAD

0424 00

THIS WORK PACKAGE COVERS:

- Removal (page 0424 00-1).
- Installation (page 0424 00-2).

INITIAL SETUP:

Maintenance Level

Unit

References

See your -10

Tools and Special Tools

- General Mechanic's Tool Kit (WP 0926 00, Item 65)
- Torque Wrench (WP 0926 00, Item 85)

Equipment Condition

- Carrier on level surface
- Carrier positioned with track pad accessible
- Engine stopped (see your -10)
- Carrier blocked (see your -10)
- Track shroud and covers removed (WP 0438 00)

Materials/Parts

Nut

Personnel Required

Unit Mechanic

REMOVAL

1. Remove nut (1) and pad (2) from track shoe (3). Discard nut.

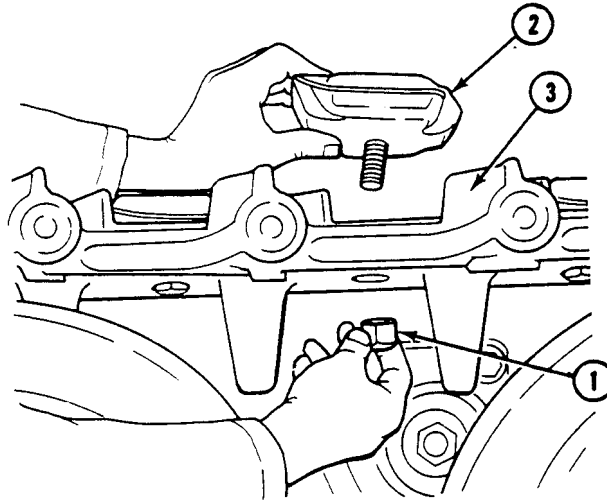

INSTALLATION

NOTE

Your carrier might have either T130 or T130E1 track, or a mixture of both. A T130E1 track pad is about 4-3/4 inches (12 cm) long. A T130 track pad is about 5-1/4 inches (13 cm) long.

1. Install track shoe pad (2) in shoe (3). Secure with new nut (1). TIGHTEN NUT TO 135-155 LB-FT (183-210 N·m) TORQUE.

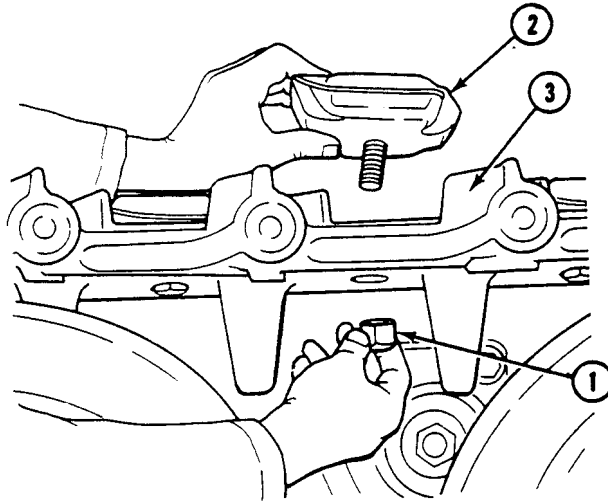

FOLLOW-THROUGH STEPS

1. Install track shroud and covers (WP 0438 00).

END OF TASK

REPLACE T150 TRACK SHOE PAD**0424 01****THIS WORK PACKAGE COVERS:**

Removal (page 0424 01-1)

Installation (page 0424 01-2)

INITIAL SETUP:Maintenance Level

Unit

Personnel Required

Unit Mechanic

Helper (H)

Tools and Special Tools

General Mechanic's Tool Kit (WP 0926, Item 65)

Torque Wrench (WP 0926 00, Item 85)

References

See your -10

Materials/Parts

Locknut

Equipment Conditions

Engine stopped (see your -10)

REMOVAL**NOTE****Left/right track shoe pads are removed and installed the same way.**

1. Start engine (see your-10).
2. Drive vehicle (see your-10). Move vehicle to reach damaged track shoe pad. Have a helper guide you.
3. Stop engine (see your-10).
4. Block vehicle (see your-10).

NOTE**Track shoe pads should be removed between drive sprocket and first road wheel or idler wheel and fifth road wheel.**

5. Remove locknut (3) from stud (4). Discard locknut.

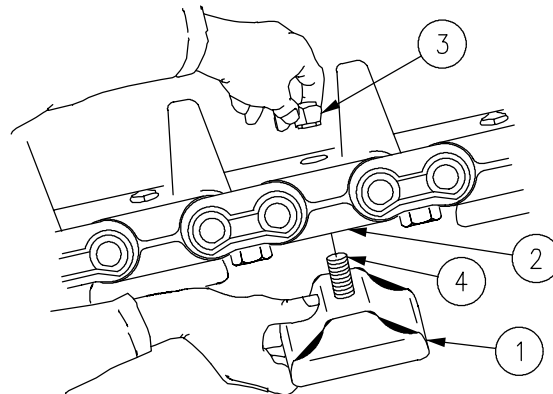
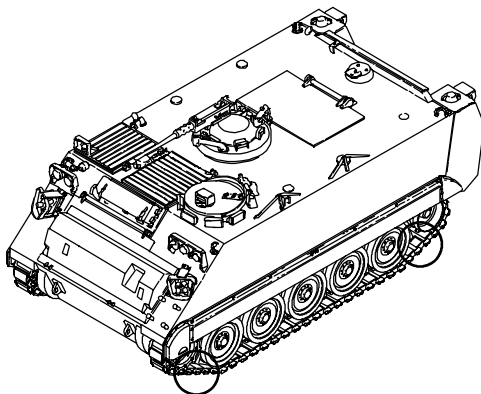

6. Tap on stud (4) and remove track shoe pad (1) from track shoe (2).

INSTALLATION

1. Install stud (4) of track shoe pad (1) through track shoe (2) from under track and install new locknut (3) on stud.

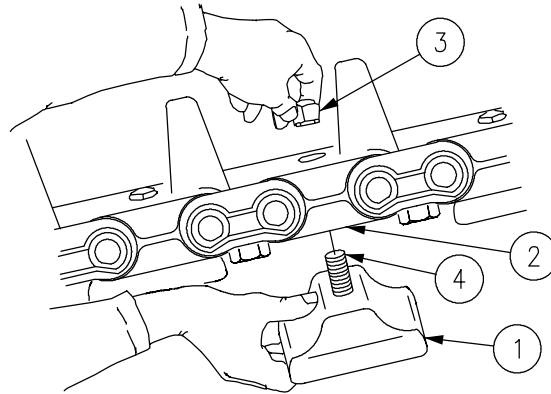

2. TIGHTEN LOCKNUT (3) TO 120-150 LB-FT (162-293 N·m) TORQUE.

FOLLOW-THROUGH STEPS

1. Unblock vehicle (see your-10).
2. Road test vehicle to check that track shoe pad is installed correct (see your-10).

END OF TASK

REPLACE IDLER WHEEL

0425 00

THIS WORK PACKAGE COVERS:

Removal (page 0425 00-1).
 Installation (page 0425 00-3).

INITIAL SETUP:

Maintenance Level

Unit

References

See your -10

Tools and Special Tools

General Mechanic's Tool Kit (WP 0926 00, Item 65)
 Torque wrench (WP 0926 00, Item 85)

Equipment Condition

Carrier on level surface
 Engine stopped (see your -10)
 Carrier blocked (see your -10)
 Track shroud and covers removed (WP 0438 00)

Materials/Parts

Locknut per wheel (8)

Personnel Required

Unit Mechanic

REMOVAL

1. Loosen idler wheel nuts (1).

REPLACE IDLER WHEEL — Continued

0425 00

2. Disconnect track (see your -10).
3. Remove track from idler wheels (2).
4. Remove eight locknuts (1) and two idler wheels (2) from idler wheel hub (3). Discard locknuts.

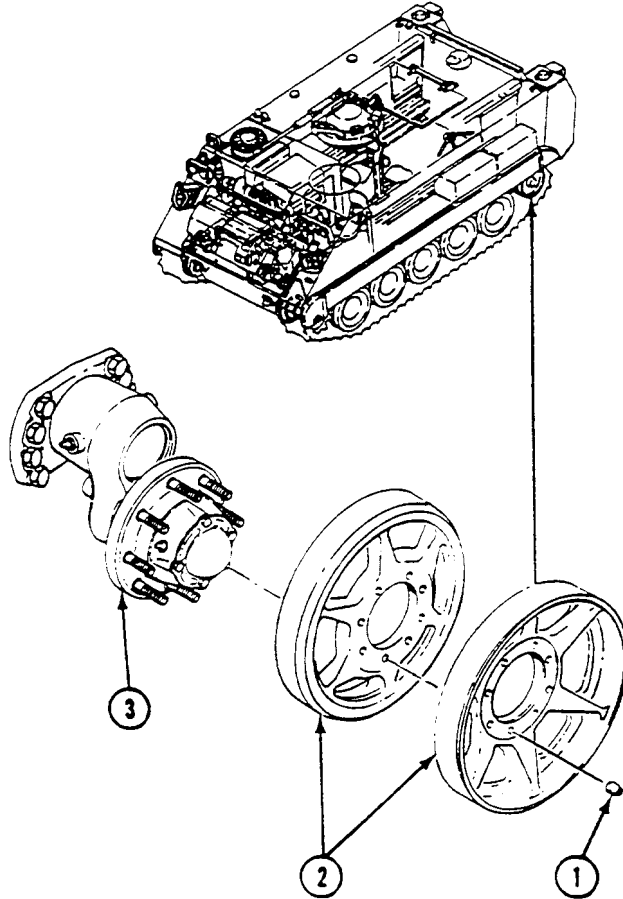

INSTALLATION**NOTE**

Inboard and outboard idler wheels are different. Do not mix them up. Inboard wheel (marked 11669373) is 3-1/4 inches (83 mm) wide. Outboard wheel (marked 10907799) is 3-1/8 inches (79 mm) wide.

1. Place two idler wheels (2) on idler wheel hub (3).

NOTE

Install inboard and outboard idler wheel in the right order. Make sure spokes do not line up.

2. Secure two wheels (2) to hub (3) with eight new nuts (1). **TIGHTEN NUTS TO 150-170 LB (203-230 N·m) TORQUE.**

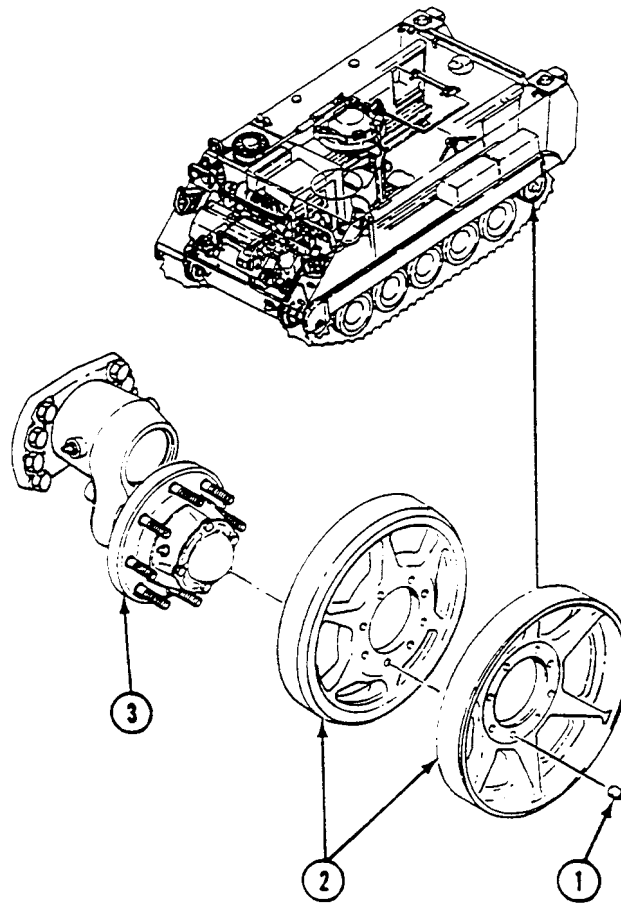

3. Install track over idler wheels.
4. Connect track and adjust tension (see your -10).

FOLLOW-THROUGH STEPS

1. Install track shroud and covers (WP 0438 00).
2. Unblock carrier (see your -10).
3. Road test carrier to check that idler wheel is installed right (WP 0155 00).

END OF TASK

REPLACE ROAD WHEEL (T130)

0426 00

THIS WORK PACKAGE COVERS:

- Removal (page 0426 00-1).
- Inspection and Repair (page 0426 00-2).
- Installation (page 0426 00-3).

INITIAL SETUP:

Maintenance Level

Unit

Tools and Special Tools

- General Mechanic's Tool Kit (WP 0926 00, Item 65)
- Road Wheel Lifter (WP 0926 00, Item 28)
- Torque Wrench (WP 0926 00, Item 85)

Materials/Parts

- Locknut, per wheel (8)

Personnel Required

- Unit Mechanic
- Helper (H)

References

- See your -10
- TM 9-2530-200-24

Equipment Condition

- Carrier on level surface
- Engine stopped (see your -10)
- Carrier blocked (see your -10)
- Track shroud and covers removed (WP 0438 00)

REMOVAL

1. Place lifter (1) under road wheel arm (2). Keep lower tips of lifter in track link just rearward of wheel being removed.
2. Loosen eight locknuts (3) on road wheel (4). Do not remove nuts.
3. Unblock carrier (see your -10).

WARNING

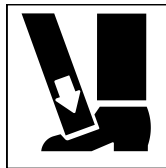

If road wheel lifter slips while lowering road arm, it could injure you. Stand clear before you lower road arm.

4. Start engine (see your -10). Place gear selector in R. Slowly back carrier until lifter (1) is vertical and road wheel (4) clears ground.

WARNING

Failure to set the parking brake and block the road wheels can allow the carrier to move and could result in injury or death. Always set the parking brake and block road wheels before working on the carrier.

5. Block carrier (see your -10).
6. Remove eight locknuts (3) and washers (5) from road wheel (4). Discard locknuts.
7. Lift track with bar until track clears road wheel (4). Remove two road wheels.

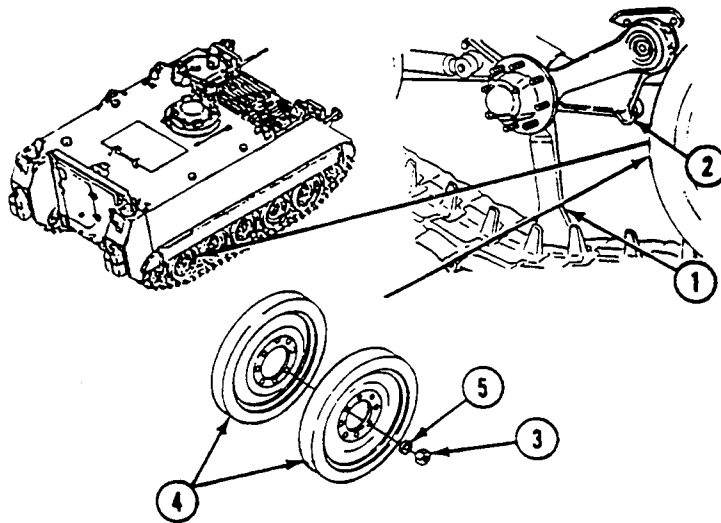
**INSPECTION AND REPAIR**

1. Check road wheel tires TM 9-2530-200-24. Replace wheel if rubber has separated from it. Replace wheel if damaged tire causes noise or vibration when carrier is moving.

INSTALLATION

1. Lift track assembly with bar. Place two road wheels (1) on road wheel arm (2). Secure loosely with eight washers (3) and new locknuts (4).
2. Unblock carrier (see your -10).

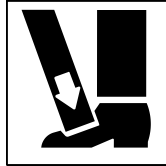
WARNING

You can be hurt if road wheel lifter slips while road arm is being lowered. Stand clear.

3. Start engine (see your -10). Place range selector in RANGE 1. Slowly drive carrier forward off lifter (5). Remove lifter.

WARNING

Failure to set the parking brake and block the road wheels can allow the carrier to move and could result in injury or death. Always set the parking brake and block road wheels before working on the carrier.

4. Block carrier (see your -10).
5. TIGHTEN EIGHT NUTS (4) TO 150-170 LB-FT (203-230 N·m) TORQUE.

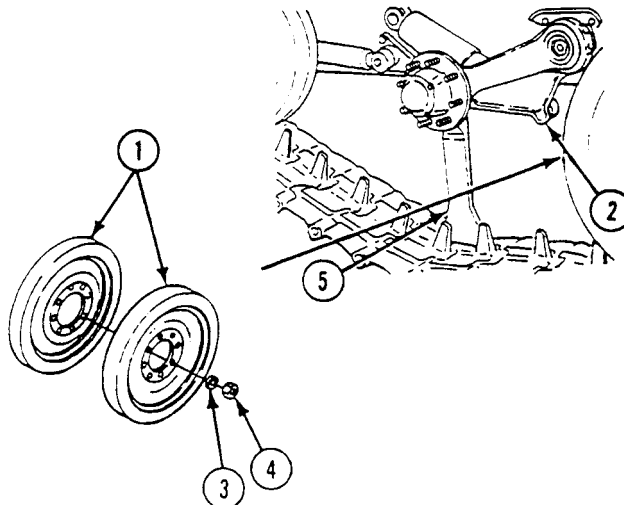

FOLLOW-THROUGH STEPS

1. Adjust track tension (see your -10).
2. Install track shroud and covers (WP 0438 00).
3. Unblock carrier (see your -10).
4. Road test carrier to check that road wheel is installed right (WP 0155 00).

END OF TASK

REPLACE ROAD WHEEL (T150)**0426 01****THIS WORK PACKAGE COVERS:**

- Inspection and Repair (page 0426 01-1)
- Removal (page 0426 01-1)
- Installation (page 0426 01-2)

INITIAL SETUP:Maintenance Level

Unit

Tools and Special Tools

- General Mechanic's Tool Kit (WP 0926, Item 65)
- Road Wheel Lifter Assembly (WP 0926, Item 28A)
- Torque Wrench (WP 0926, Item 85)

Materials/Parts

Locknut, per wheel (8)

Personnel Required

- Unit Mechanic
- Helper (H) (2)

References

- See your -10
- TM 9-2530-200-24

Equipment Conditions

- Carrier on firm level surface
- Engine stopped (see your -10)
- Carrier blocked (see your -10)
- Track shroud and covers removed (WP 0438 00)
- Break track (only if doing road wheel number 1 or 5) (see your -10)

INSPECTION

Check road wheel tires (see TM 9-2530-200-24). Replace wheel if rubber has separated from it. Replace wheel if damaged tire causes noise or vibration when carrier is moving.

REMOVAL

1. Remove two T-nuts (1), screws (2), flat washers (3), retainer (4), and lifter (5) from road wheel lifter assembly.

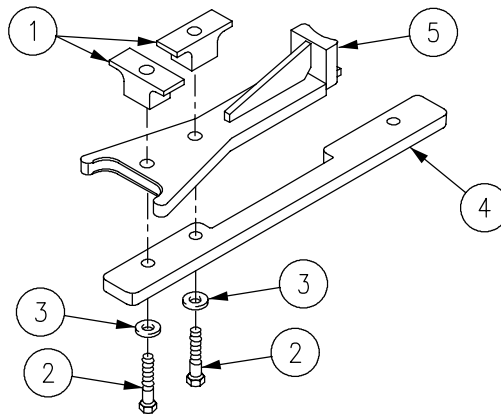

2. Loosen eight locknuts (7) on road wheel (9). Do not remove nuts.
3. Install retainer (4), two flat washers (3), screws (2) and T-nuts (1) on inside of track assembly.

WARNING

Position retainer stops inside of end connectors to prevent the lifter from slipping off and causing injury and/or death to personnel.

4. Place lifter (5) under road wheel arm (6). Keep lower tips of lifter in track link just rearward of wheel being removed.
5. Unblock carrier (see your -10).

WARNING

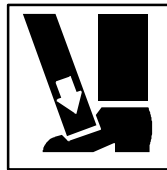

If road wheel lifter slips while lowering road arm, it could injure you. Stand clear before you lower road arm.

6. Start engine (see your -10). Place gear selector in R. Slowly back carrier until lifter (5) is vertical and road wheel (9) clears ground.

WARNING



Failure to set the parking brake and block the road wheels can allow the carrier to move and could result in injury or death. Always set the parking brake and block road wheels before working on the carrier.

7. Block carrier (see your -10).
8. Remove eight locknuts (7) and washers (8) from road wheel (9). Discard locknuts.
9. Lift track with bar until track clears road wheel (9). Remove two road wheels.

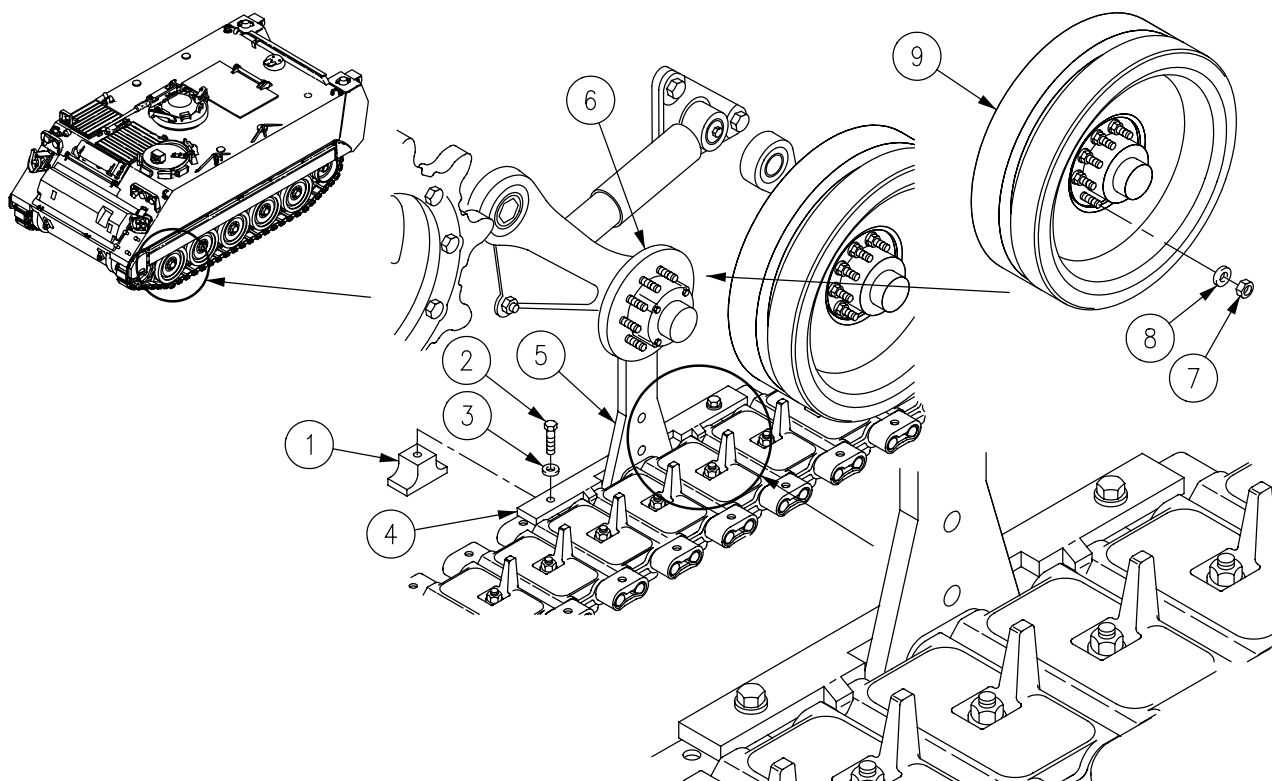

INSTALLATION

1. Lift track assembly with bar. Place two road wheels (1) on road wheel arm (2). Secure loosely with eight washers (3) and new locknuts (4).
2. Unblock carrier (see your -10).

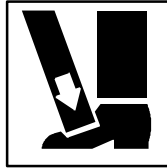
WARNING

You can be hurt if road wheel lifter slips while road arm is being lowered. Stand clear.

3. Start engine (see your -10). Place range selector in RANGE 1. Slowly drive carrier forward off lifter (5). Remove lifter.

WARNING

Failure to set the parking brake and block the road wheels can allow the carrier to move and could result in injury or death. Always set the parking brake and block road wheels before working on the carrier.

4. Remove two T-nuts (6), screws (7), flat washers (8), and retainer (9) from lifter (5) and remove road wheel lifter assembly from track.
5. Block carrier (see your-10).
6. TIGHTEN EIGHT NUTS (4) TO 150-170 LB-FT (203-230 N·m) TORQUE.

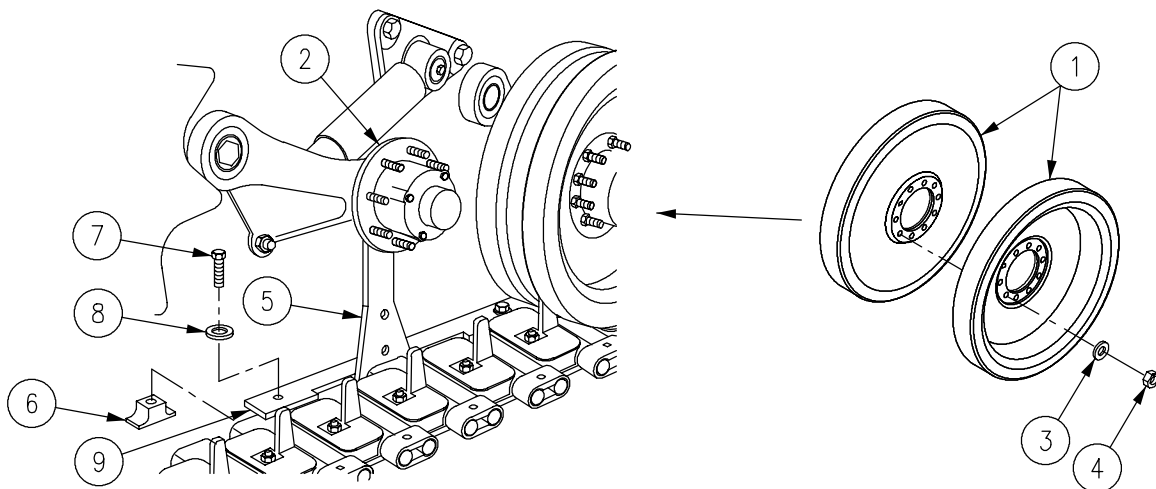

REPLACE ROAD WHEEL (T150) - Continued**0426 01**

7. Assemble road wheel lifter assembly by installing retainer (4), two flat washers (3), screws (2), and T-nuts (1) on road wheel lifter (5).

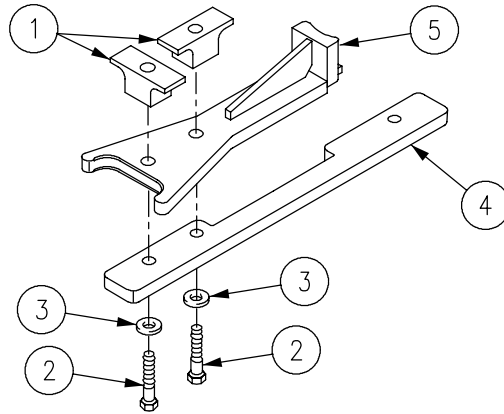
**FOLLOW-THROUGH STEPS**

1. Join track if road wheel number 1 or 5 (see your -10).
2. Adjust track tension (see your -10).
3. Install track shroud and covers (WP 0438 00).
4. Unblock carrier (see your -10).
5. Road test carrier to check that road wheel is installed right (see your -10).

END OF TASK

CHAPTER 14

UNIT MAINTENANCE INSTRUCTIONS
FOR STEERING

WORK PACKAGE INDEX

<u>Title</u>	<u>Sequence No.</u>
ADJUST STEERING WHEEL LINKAGE.....	0427 00
REPLACE STEERING LOCK SOLENOID, BRACKET, LINKS, AND PINS (SOLENOID-ACTIVATED LOCK).....	0428 00
REPLACE PUSH-PULL CONTROL ASSEMBLY, BRACKET, LINKS, AND PINS (CABLE-ACTIVATED LOCK).....	0429 00
REPLACE STEERING WHEEL LINKAGE.....	0430 00
REPLACE QUICK RELEASE PIN AND LANYARD.....	0431 00
REPLACE STEERING SUPPORT, BRACKETS, AND SHAFT.....	0432 00

ADJUST STEERING WHEEL LINKAGE

0427 00

THIS WORK PACKAGE COVERS:

Adjustment (page 0427 00-1).

INITIAL SETUP:

Maintenance Level

Unit

References

See your -10

Tools and Special Tools

General Mechanic's Tool Kit (WP 0926 00, Item 65)

Equipment Condition

- Engine stopped (see your -10)
- Carrier blocked (see your -10)
- Trim vane lowered (see your -10)
- Power plant access door opened (see your -10)
- Driver's power plant access panel removed (see your -10)

Materials/Parts

Locknut (2)

Personnel Required

Unit Mechanic

ADJUSTMENT

1. Loosen jamnut (1) on rod end bearing (2).
2. Loosen jamnut (3) on rod end bearing (4).

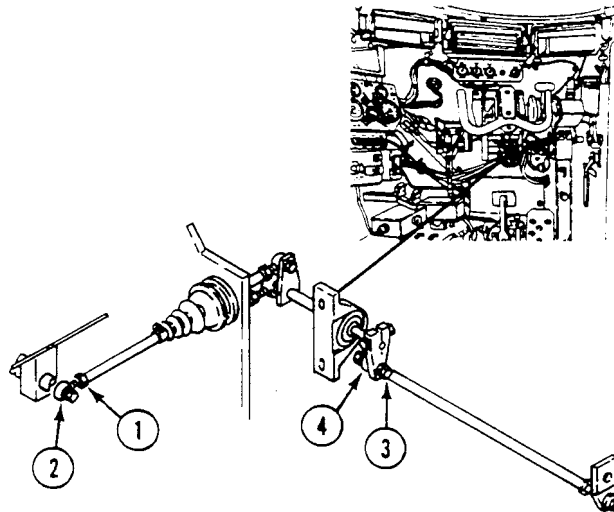

3. Remove screw (5), washer (6), and locknut (7) from link (8) and arm (9). Discard locknut.

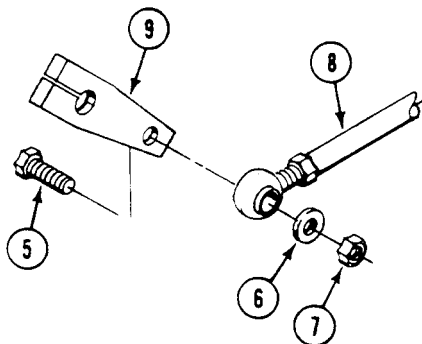

4. Remove screw (10), washer (11), and locknut (12) from link (13) and arm (14). Discard locknut.

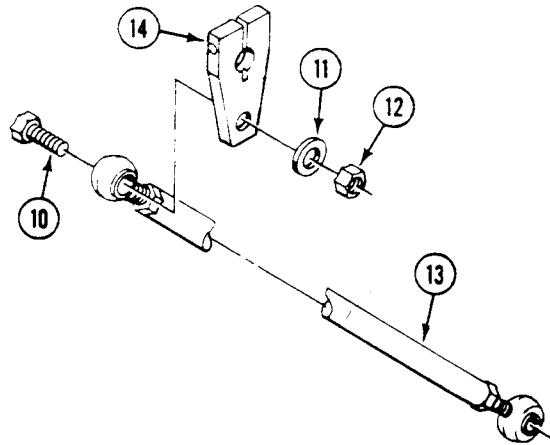

5. Center steering wheel (15) by centering steering wheel spring (16).

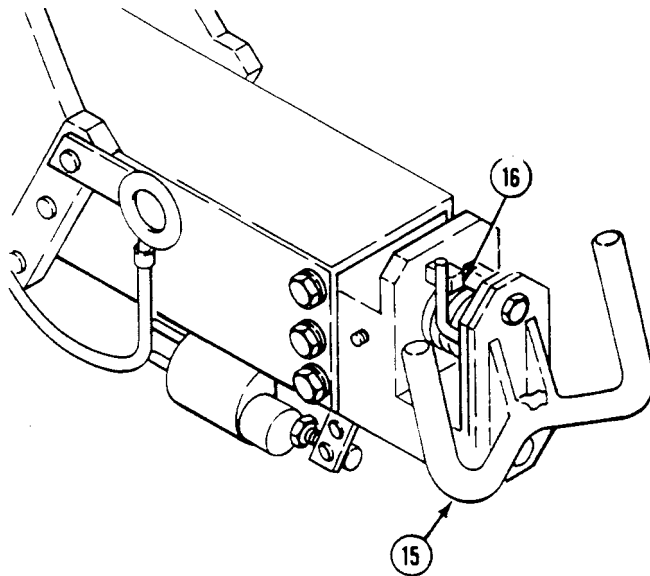

6. Adjust rod end bearing (1) and rod end bearing (2) until there is a free pin fit.

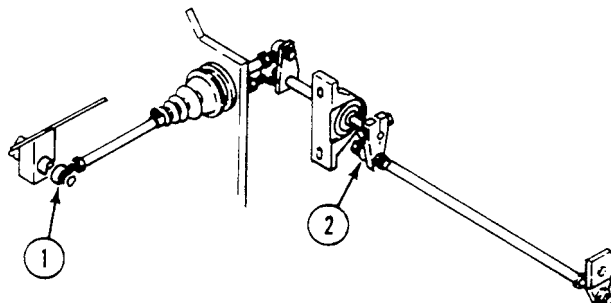

- Secure link (3) on arm (4) with screw (5), washer (6), and new locknut (7).

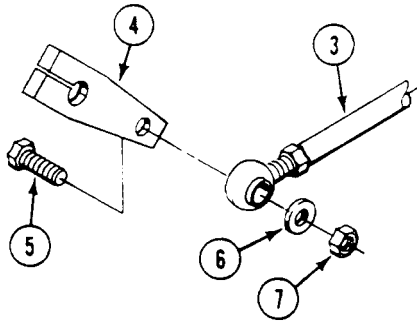

- Secure link (8) on arm (9) with screw (10), washer (11), and new locknut (12).

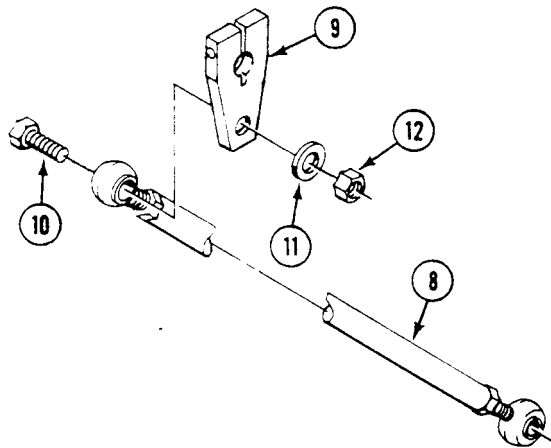

- Tighten jamnut (13) on link (3) and jamnut (14) on link (8).

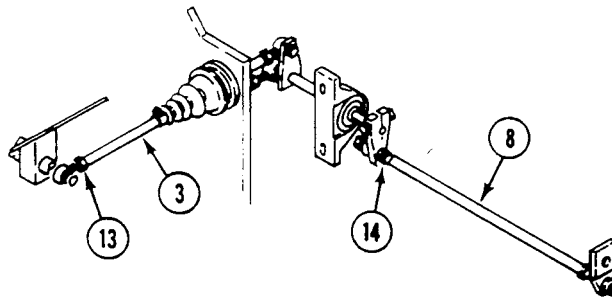

FOLLOW-THROUGH STEPS

- Install driver's power plant access panel (see your -10).
- Close power plant access door (see your -10).
- Raise trim vane (see your -10).

END OF TASK

**REPLACE STEERING LOCK SOLENOID, BRACKET, LINKS, AND PINS
(SOLENOID-ACTIVATED LOCK)**

0428 00

THIS WORK PACKAGE COVERS:

- Removal (page 0428 00-1).
- Installation (page 0428 00-5).
- Adjustment (page 0428 00-7).

INITIAL SETUP:

Maintenance Level

Unit

Personnel Required

Unit Mechanic

Tools and Special Tools

General Mechanic's Tool Kit (WP 0926 00, Item 65)

References

See your -10

Materials/Parts

Sealing compound (WP 0928 00, Item 47)

Wiping rag (WP 0928 00, Item 65)

Cotter pin (2)

Spring pin (2)

Spring pin

Spring pin

Equipment Condition

Engine stopped (see your -10)

Carrier blocked (see your -10)

REMOVAL

1. Remove nut (1) securing lead 368A (2) to solenoid (3).

**REPLACE STEERING LOCK SOLENOID, BRACKET, LINKS, AND PINS
(SOLENOID-ACTIVATED LOCK) — Continued**

0428 00

2. Remove nut (4) securing ground lead (5) to solenoid (3).
3. Disconnect electrical lead 369 (6) and 369A (7).
4. Remove two screws (8) and washers (9) that secure solenoid (3) to steering wheel housing (10).

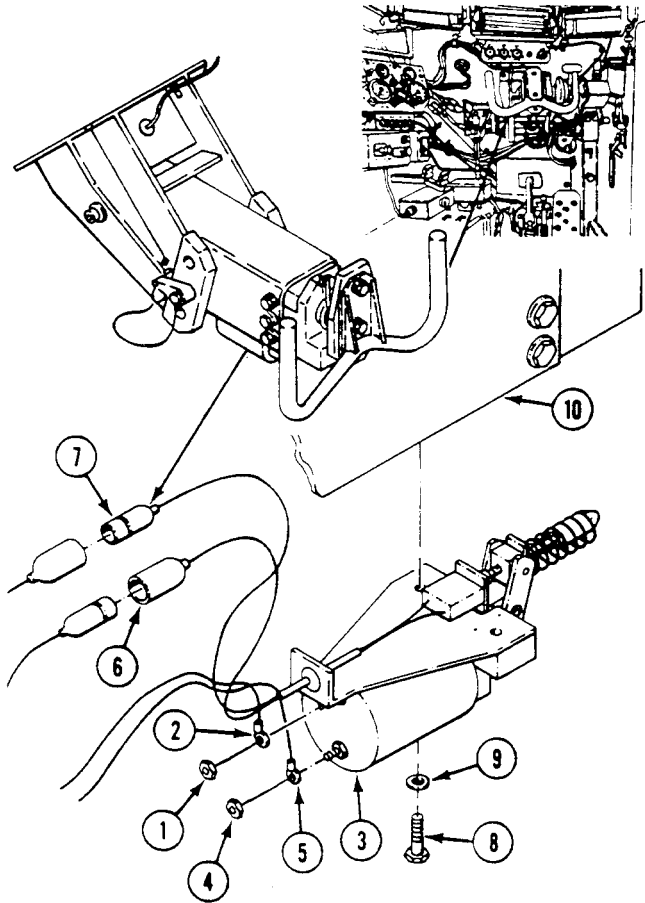

**REPLACE STEERING LOCK SOLENOID, BRACKET, LINKS, AND PINS
(SOLENOID-ACTIVATED LOCK) — Continued**

0428 00

5. Remove spring (1) from locking pin (2).
6. Remove nut (3) and lockwasher (4) that secure switch (5) to solenoid bracket (6).
7. Remove switch (5) and bracket (7) from solenoid bracket (6).

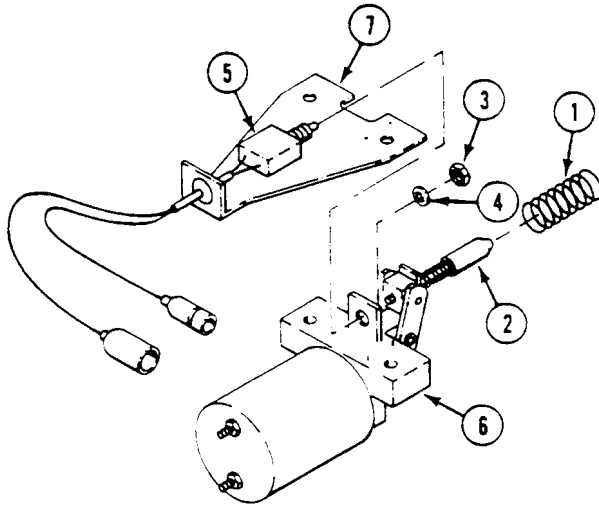

8. Remove cotter pin (8), two washers (9), and pin (10) that secure rod end (11) to links (12). Discard cotter pin.
9. Remove cotter pin (13), two washers (14), and pin (15) that secure links (12) to bracket (6). Discard cotter pin.
10. Remove two links (12) from locking pin (2).

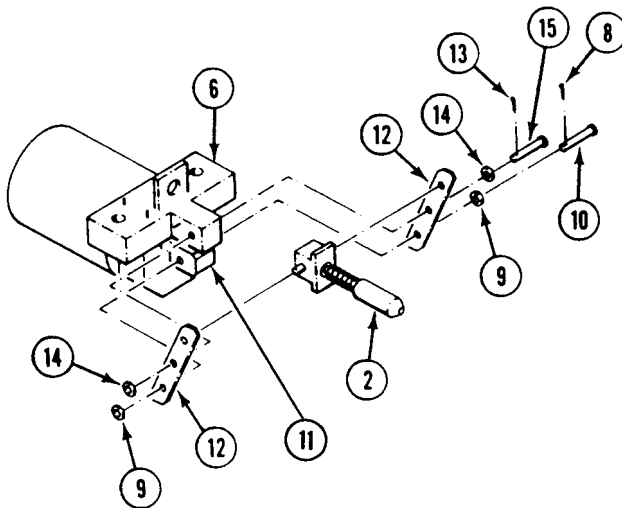

REPLACE STEERING LOCK SOLENOID, BRACKET, LINKS, AND PINS
(SOLENOID-ACTIVATED LOCK) — Continued

0428 00

11. Remove spring pin (16) from locking pin (2) and remove block (17). Discard spring pin.
12. Remove spring (18) from locking pin (2).

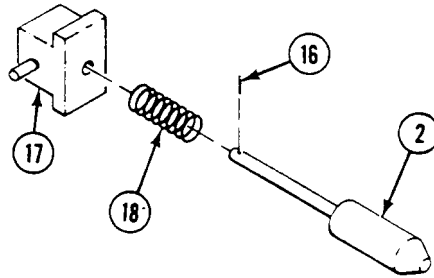
**NOTE**

Do not remove plunger from solenoid.

13. Loosen jam nut (19) and remove rod end (11) from solenoid (20).

CAUTION

Use care not to damage solenoid when clamping it or using tools on it.

14. Place bracket (6) in vice. Unscrew solenoid (20) from bracket (6).
15. Remove three spring pins (21) from bracket (6). Discard spring pins.

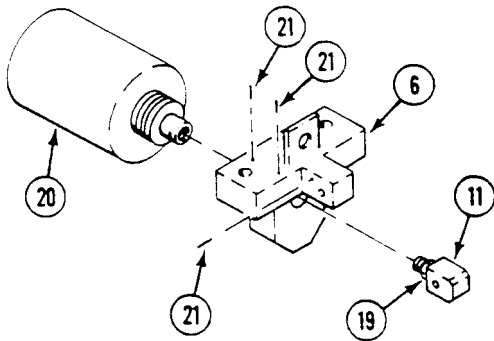

REPLACE STEERING LOCK SOLENOID, BRACKET, LINKS, AND PINS
(SOLENOID-ACTIVATED LOCK) — Continued

0428 00

INSTALLATION

1. Install three new spring pins (1) in bracket (2).
2. Apply sealing compound to male threads of solenoid (3). Do not apply sealant beyond small end of tapered threads.
3. Screw solenoid (3) into bracket (2).
4. Install rod end (4) with jam nut (5) in plunger (6), approximately 1/2 inch distance of screw threads.

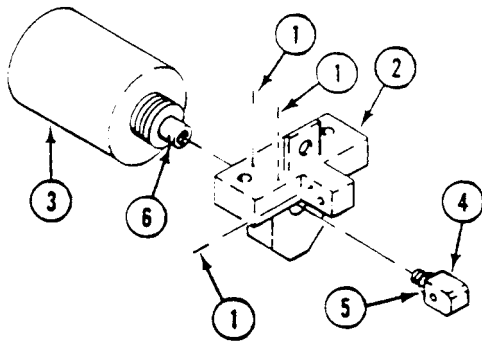

5. Install spring (7) on locking pin (8).
6. Install block (9) on locking pin (8). Secure with new spring pin (10).

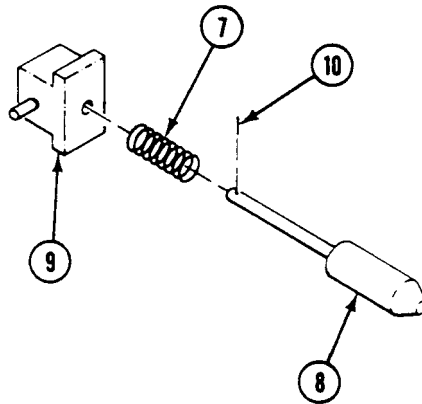

**REPLACE STEERING LOCK SOLENOID, BRACKET, LINKS, AND PINS
(SOLENOID-ACTIVATED LOCK) — Continued**

0428 00

7. Insert locking pin (8) between end holes of two links (11).

NOTE

The end of links with the 45° beveled elongated holes should be installed on locking pin. The end of the links without the beveled elongated holes should be installed on the solenoid rod end.

8. Install rod end (4) in link (11) end holes opposite locking pin (8). Secure with pin (12), two washers (13), and new cotter pin (14).

NOTE

When installing links on bracket, make sure locking pin faces opposite solenoid.

9. Install links (11) on bracket (2) and secure using pin (16), two washers (17), and new cotter pin (18).

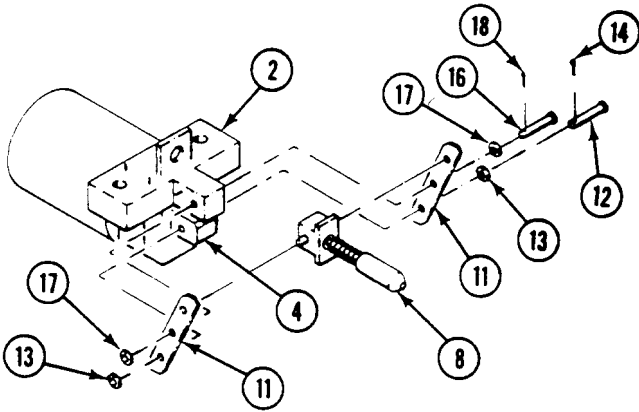

10. Insert switch bracket (19) on two spring pins (1) on solenoid bracket (2).
11. Install switch (20) on solenoid bracket (2). Secure with lockwasher (21) and nut (22).

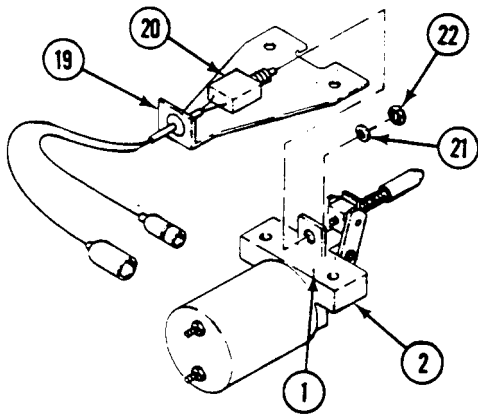

**REPLACE STEERING LOCK SOLENOID, BRACKET, LINKS, AND PINS
(SOLENOID-ACTIVATED LOCK) — Continued**

0428 00

ADJUSTMENT

1. Use a 6-inch ruler to measure the distance from solenoid housing (1) to center of rod end pin (2).
2. Depress solenoid plunger (3) in until it bottoms in solenoid housing (1). Measure the distance from solenoid housing to the center of the rod end pin (4). The difference between the two measured distances should be $1/2 \pm 1/32$ inch ($12.7 \pm .8$ mm).

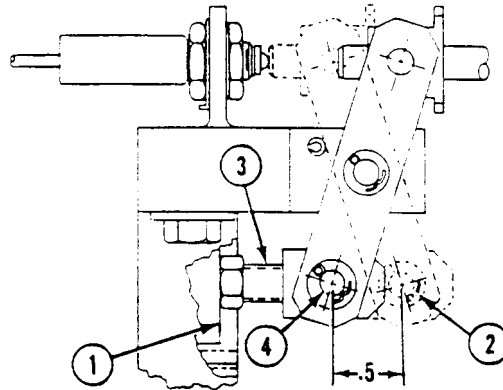
**CAUTION**

Do not grip solenoid plunger with tools. Steady by inserting awl into side hole.

3. Adjust stroke of rod end (5) by loosening jam nut (6) and turning solenoid plunger (3) clockwise or counterclockwise.

NOTE

Do not allow plunger to turn while tightening jam nut on rod end.

4. Tighten jam nut (6) on plunger (3).

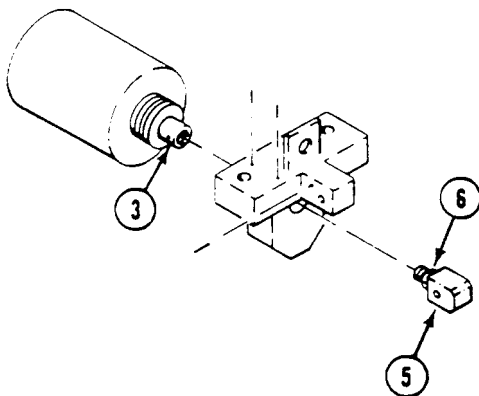

REPLACE STEERING LOCK SOLENOID, BRACKET, LINKS, AND PINS
(SOLENOID-ACTIVATED LOCK) — Continued

0428 00

5. With links (7) resting on spring pin (8), loosen two jam nuts (9)(10) on switch (11).

NOTE

Make sure switch plunger is contacting end of locking pin while adjusting switch.

6. Push switch (11) in until switch plunger (12) is fully depressed.
7. Turn jam nut (9) until it just touches bracket (13), then turn it one half turn more.
8. Tighten second jam nut (10) to secure switch (11) to bracket (13).

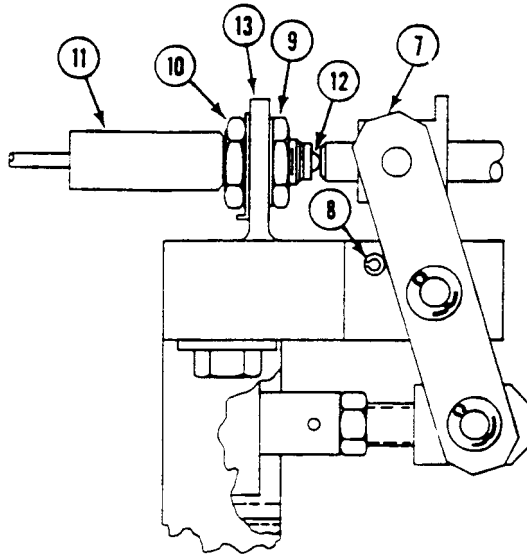

**REPLACE STEERING LOCK SOLENOID, BRACKET, LINKS, AND PINS
(SOLENOID-ACTIVATED LOCK) — Continued**

0428 00

9. Install spring (1) on locking pin (2).
10. Install solenoid (3) on steering wheel housing (4). Secure with two washers (5) and screws (6).
11. Slide solenoid (3) forward until locking pin (2) is flush with housing face.
12. Secure solenoid (3) in place by tightening two screws (6).

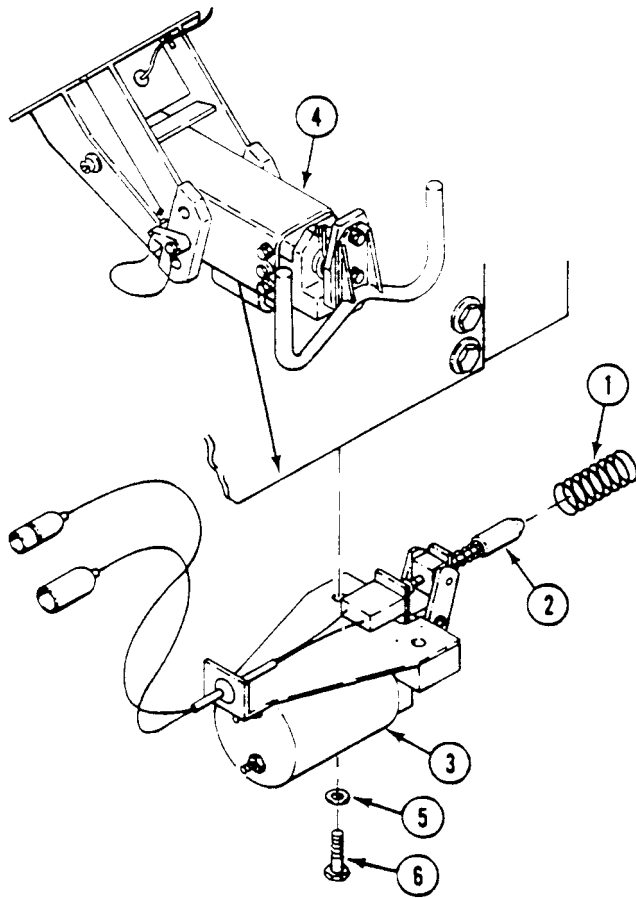

REPLACE STEERING LOCK SOLENOID, BRACKET, LINKS, AND PINS
(SOLENOID-ACTIVATED LOCK) — Continued

0428 00

13. Install lead 368A (7) on solenoid (3) and secure with nut (8).
14. Install ground lead (9) on solenoid (3) and secure with nut (10).
15. Connect leads 369 (11) and 369A (12).

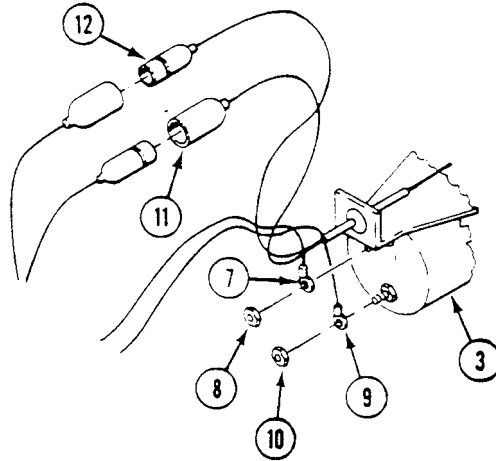

REPLACE STEERING LOCK SOLENOID, BRACKET, LINKS, AND PINS
(SOLENOID-ACTIVATED LOCK) — Continued

0428 00

16. Rotate steering wheel 30 degrees in either direction. Hold steering wheel in this position.
17. Place transmission selector in SL position.
18. Turn MASTER SWITCH ON (see your -10).
19. Observe that STEERING LOCKED warning light is off.
20. If STEERING LOCKED light comes on, loosen two screws (1) that secure solenoid (2) to steering wheel housing (3).
21. Slide bracket (4) toward steering wheel until STEERING LOCKED light goes out.
22. Tighten two screws (1) that secure solenoid (2) to steering wheel housing (3).
23. Center steering wheel, and make sure steering wheel locks and STEERING LOCKED light comes on.
24. Turn MASTER SWITCH OFF (see your -10).

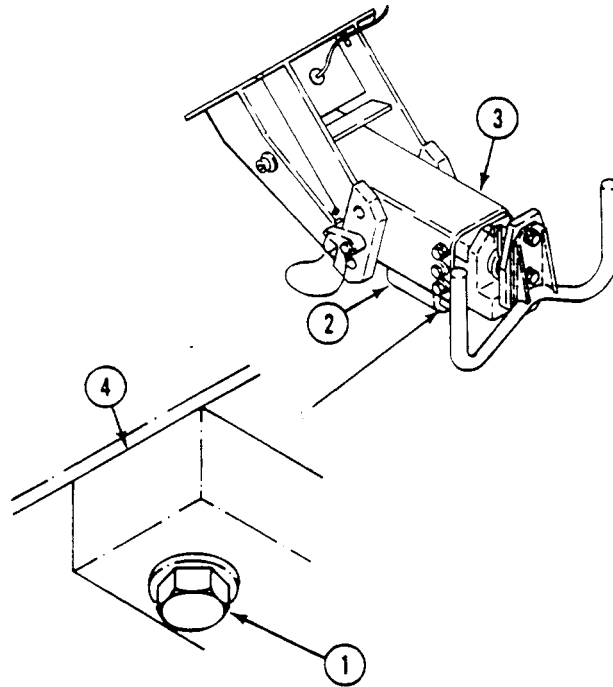
**END OF TASK**

REPLACE PUSH-PULL CONTROL ASSEMBLY, BRACKET, LINKS, AND PINS (CABLE-ACTIVATED LOCK)

0429 00

THIS WORK PACKAGE COVERS:

- Removal (page 0429 00-1).
- Installation (page 0429 00-7).
- Adjustment (page 0429 00-12).

INITIAL SETUP:

Maintenance Level

Unit

Personnel Required

Unit Mechanic

Tools and Special Tools

General Mechanic's Tool Kit (WP 0926 00, Item 65)

Materials/Parts

- Sealing compound (WP 0928 00, Item 47)
- Wiping rag (WP 0928 00, Item 65)
- Cotter pin (3)
- Lockwasher (2)
- Spring pin (2)
- Spring pin
- Spring pin
- Strap (2)

References

See your -10

Equipment Condition

- Engine stopped (see your -10)
- Carrier blocked (see your -10)

REMOVAL

1. Remove cotter pin (1), two washers (2), pin (3), and push-pull control assembly (4) from transmission controller (5). Discard cotter pin.

**REPLACE PUSH-PULL CONTROL ASSEMBLY, BRACKET, LINKS, AND PINS
(CABLE-ACTIVATED LOCK) — Continued**

0429 00

- Remove nut (6) and lockwasher (7) from end of push-pull control assembly (4). Remove end of push-pull control assembly (4) from bracket (8) on controller (5). Install nut (6) on end of assembly for future use. Discard lockwasher.

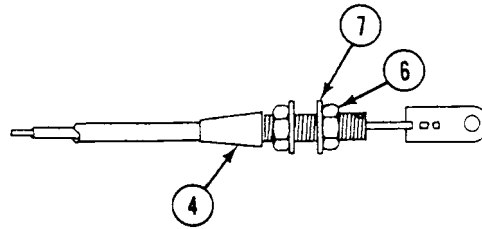
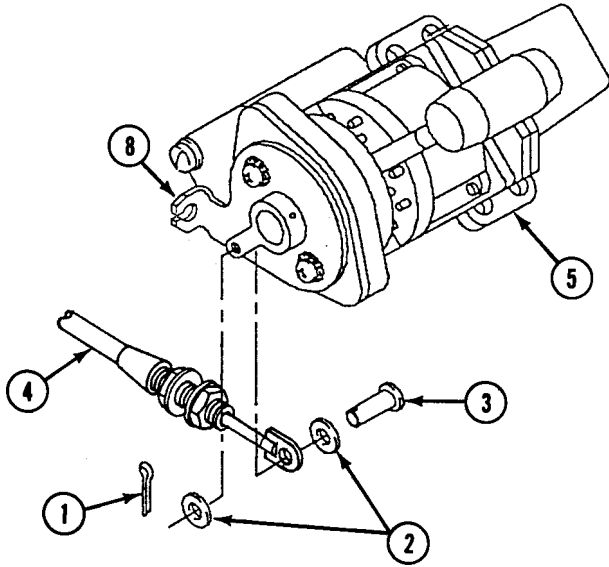
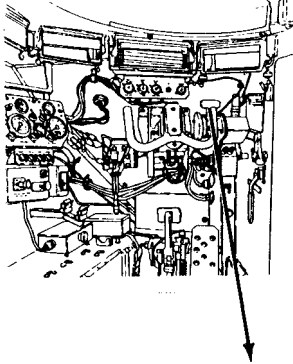

**REPLACE PUSH-PULL CONTROL ASSEMBLY, BRACKET, LINKS, AND PINS
(CABLE-ACTIVATED LOCK) — Continued**

0429 00

3. Remove screw (1), lockwasher (2), and clamp (3) securing push-pull control assembly (4) to front of hull. Discard lockwasher.
4. Remove two straps (5) securing leads 369A (6) and 368 (7) inside steering wheel housing (8).

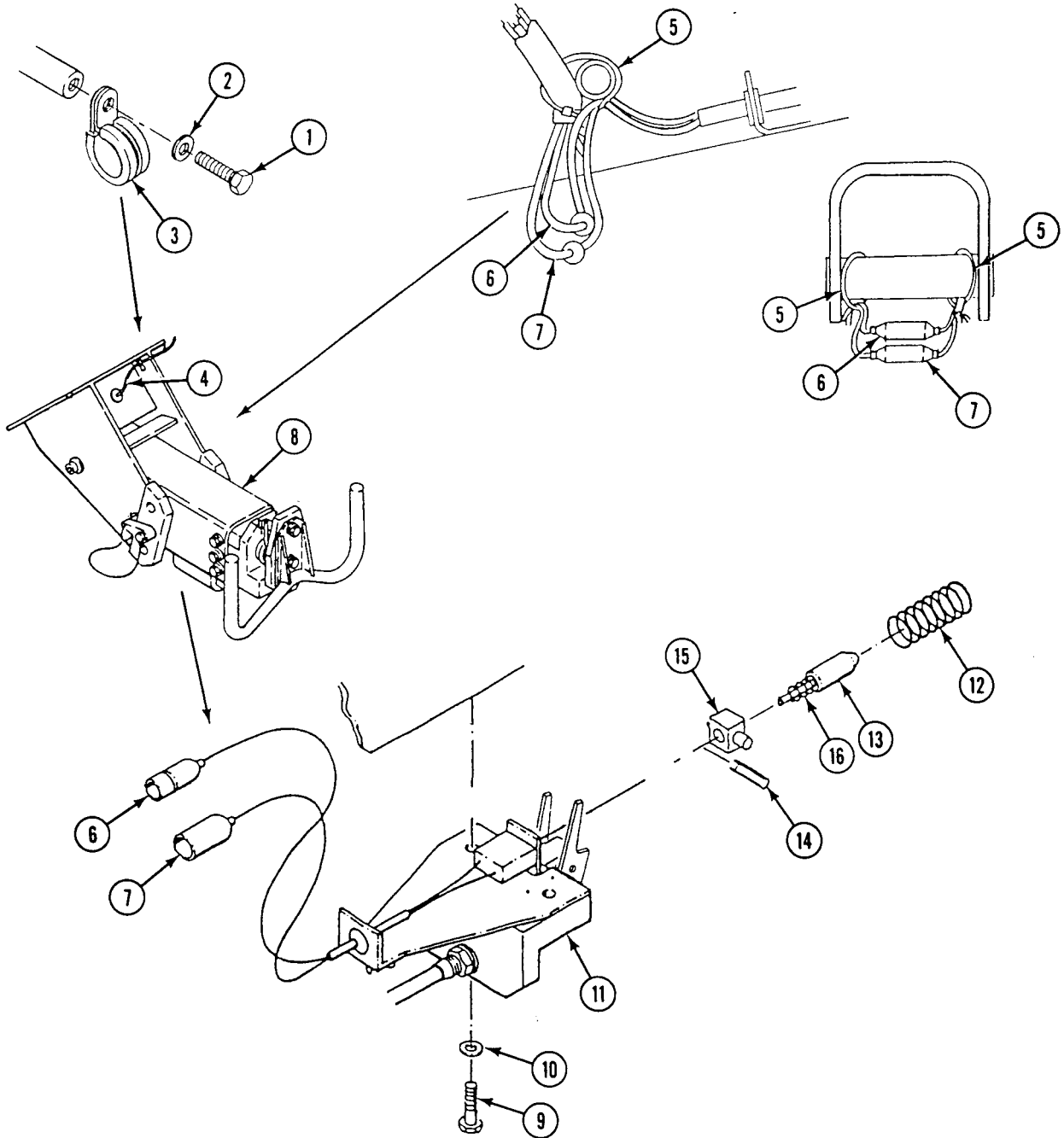

**REPLACE PUSH-PULL CONTROL ASSEMBLY, BRACKET, LINKS, AND PINS
(CABLE-ACTIVATED LOCK) — Continued**

0429 00

5. Disconnect circuit lead 369A (6) and lead 368 (7) from wiring harness.

NOTE

Do not drop locking pin, block, and spring when removing mounting bracket.

6. Remove two screws (9), washers (10) and mounting bracket (11) from wheel housing (8).
7. Remove spring (12) from locking pin (13). Remove pin (14) from locking pin (13). Remove block (15) and spring (16) from locking pin (13). Discard pin.

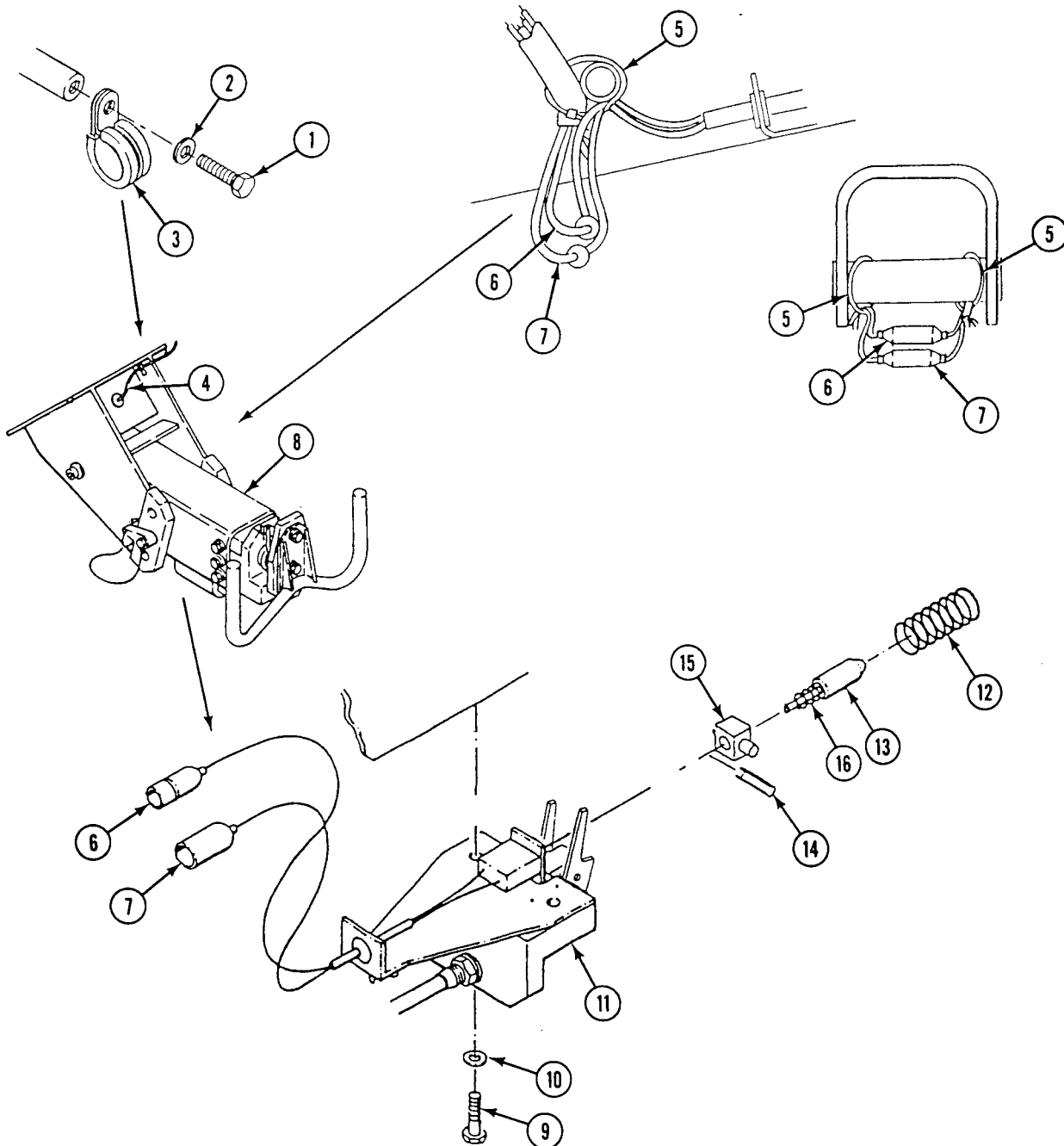

REPLACE PUSH-PULL CONTROL ASSEMBLY, BRACKET, LINKS, AND PINS
(CABLE-ACTIVATED LOCK) — Continued

0429 00

8. Remove nut (1) and lockwasher (2) that secure switch (3) to bracket (4). Discard lockwasher.

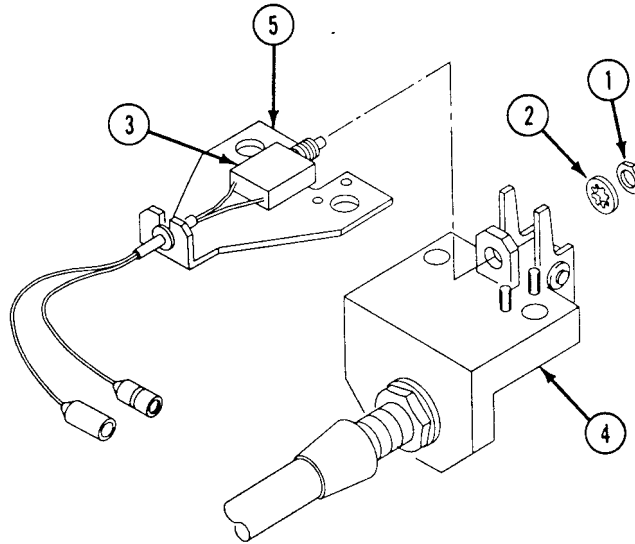

REPLACE PUSH-PULL CONTROL ASSEMBLY, BRACKET, LINKS, AND PINS
(CABLE-ACTIVATED LOCK) — Continued

0429 00

NOTE

Washers are also used as shims to insure proper fit. The number of washers will vary accordingly.

9. Remove cotter pin (6), washers (7), and pin (8) that secure push-pull control assembly (9) to links (10). Discard cotter pin.
10. Remove nut (11), lockwasher (12), and push-pull control assembly (9) from bracket (4).
11. Remove cotter pin (13), two washers (14), and pin (15) that secure links (10) to bracket (4). Discard cotter pin.

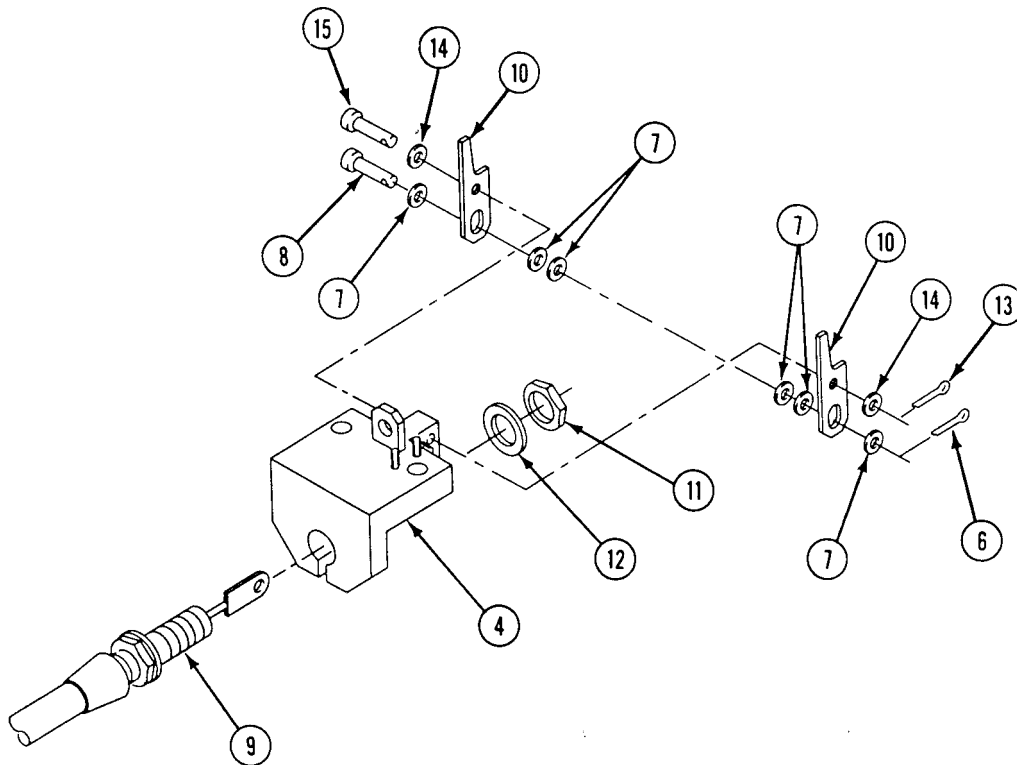

**REPLACE PUSH-PULL CONTROL ASSEMBLY, BRACKET, LINKS, AND PINS
(CABLE-ACTIVATED LOCK) — Continued**

0429 00

1. Install three new spring pins (17) and (5) on bracket (6).
2. Install spring (4) on locking pin (2).
3. Install block (3) on locking pin (2) with new pin (1).
4. Install links (7) to bracket (6) by aligning the center holes of the links with the uppermost holes of bracket (6) and inserting pin (8), washers (9), and new cotter pin (10).
5. Install push-pull control assembly (11), new lockwasher (12), and nut (13) on bracket (6).

NOTE

Washers are also used as shims to insure proper fit and to center end of push-pull assembly.

6. Install pin (14), links (7), washers (shims) (15) as needed, push-pull control assembly (11), and new cotter pin (16).

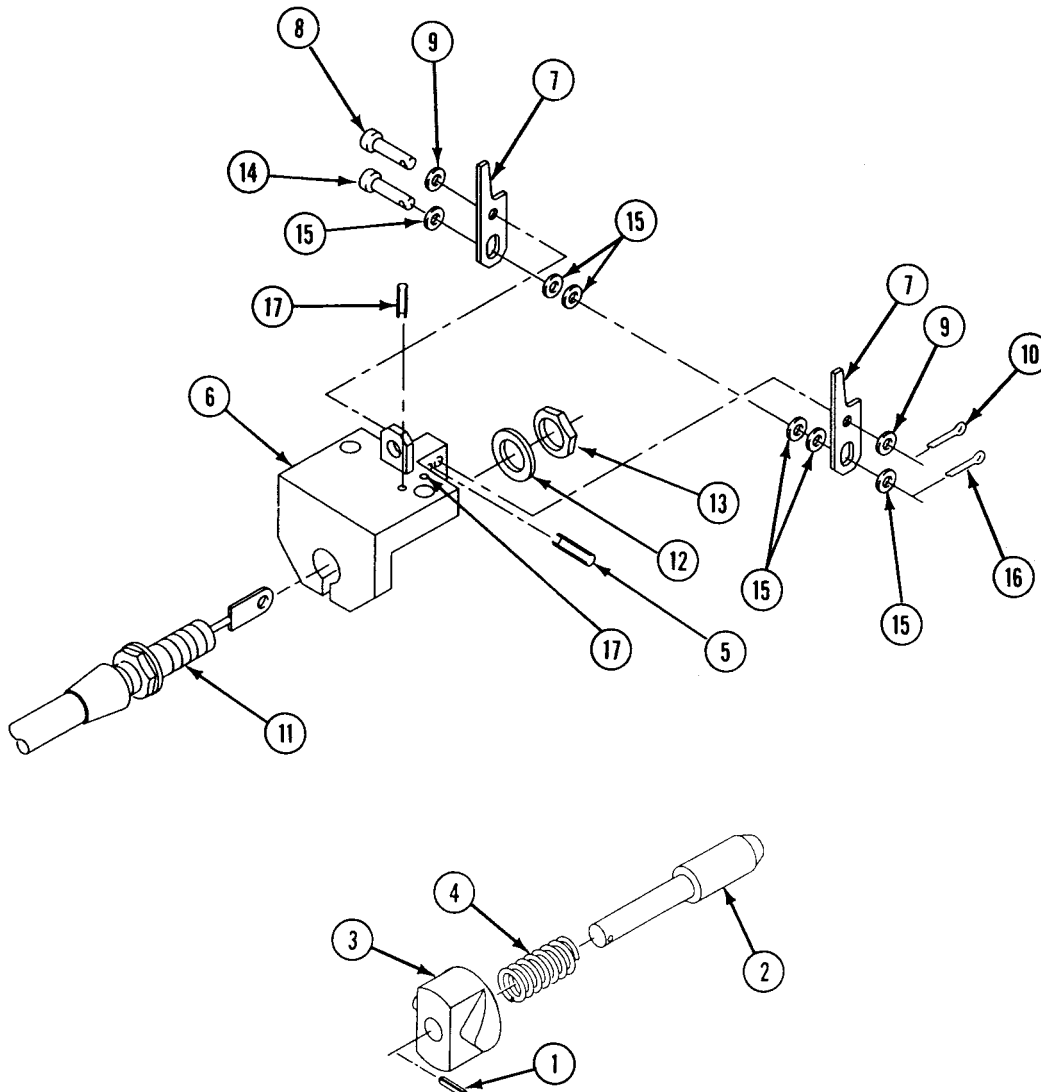

**REPLACE PUSH-PULL CONTROL ASSEMBLY, BRACKET, LINKS, AND PINS
(CABLE-ACTIVATED LOCK) — Continued**

0429 00

7. Install switch bracket (1) on spring pins (2) on bracket (3).
8. Install switch (4), new lockwasher (5), and nut (6) on bracket (3).

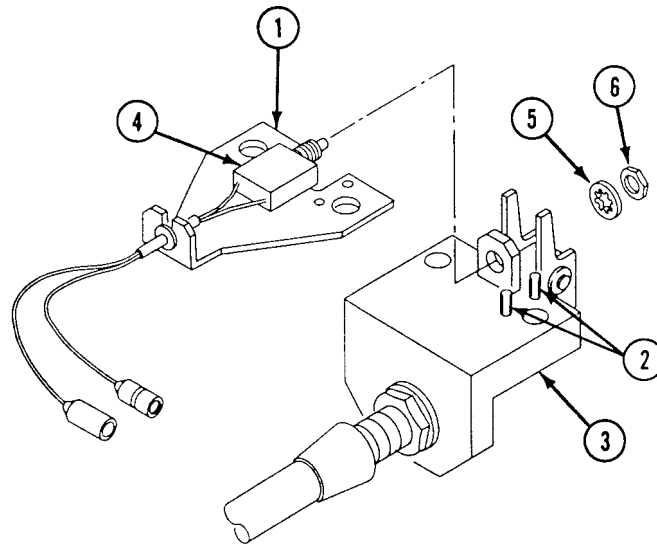

**REPLACE PUSH-PULL CONTROL ASSEMBLY, BRACKET, LINKS, AND PINS
(CABLE-ACTIVATED LOCK) — Continued**

0429 00

NOTE

Route push-pull control assembly with one end at transmission controller and other end at steering wheel housing.

9. Install push-pull control assembly (7) in clamp (8) and secure to hull with screw (9) and new lockwasher (10).
10. Route push-pull control assembly (7) to transmission controller (11).
11. Remove nut (12) from end of push-pull control assembly (7). Place end of push-pull control assembly (7) through hole in bracket (13). Install new lockwasher (14) and nut (12).
12. Connect end of push-pull control assembly (7) to bracket (15) with pin (16), two washers (17) and new cotter pin (18).

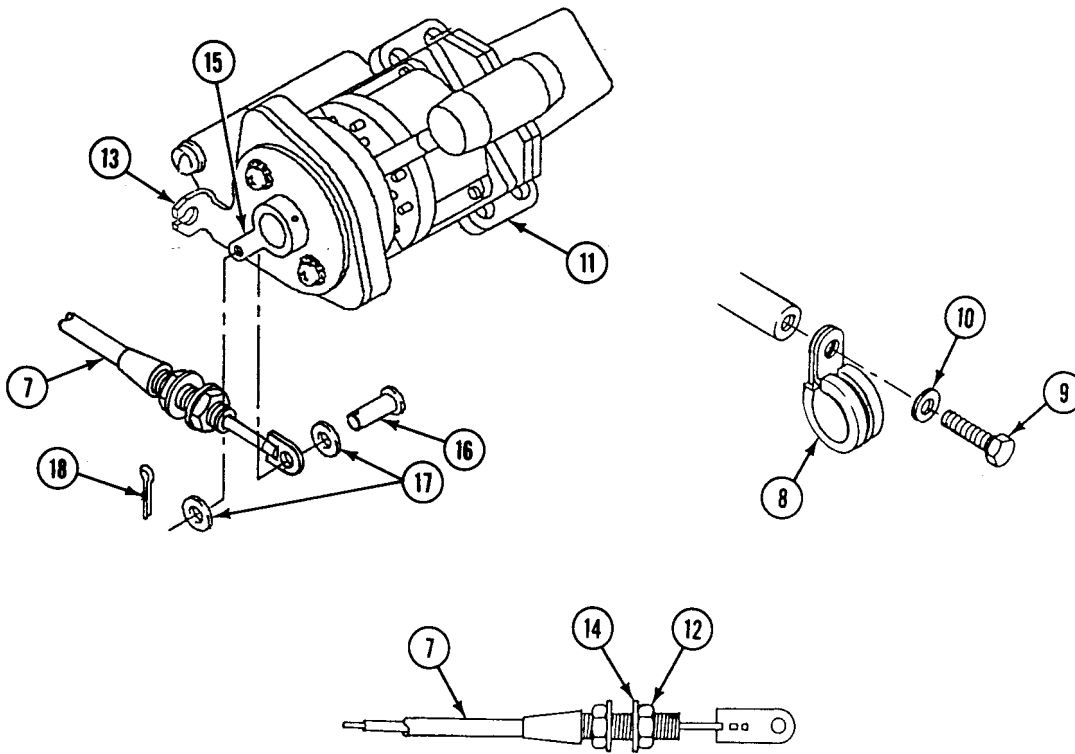

**REPLACE PUSH-PULL CONTROL ASSEMBLY, BRACKET, LINKS, AND PINS
(CABLE-ACTIVATED LOCK) — Continued**

0429 00

13. With the links (1) resting on spring pin (2), loosen two jamnuts (3) and (4) on switch (5).

NOTE

Make sure switch plunger is contacting end of locking pin while adjusting switch.

14. Push switch (5) in until switch plunger (6) is fully depressed.
15. Turn jamnut (3) until it touches bracket (7), then turn it back one half turn.
16. Tighten second jamnut (4) to secure switch (5) to bracket (7).
17. Install block (14) and locking pin (13) between links (1).

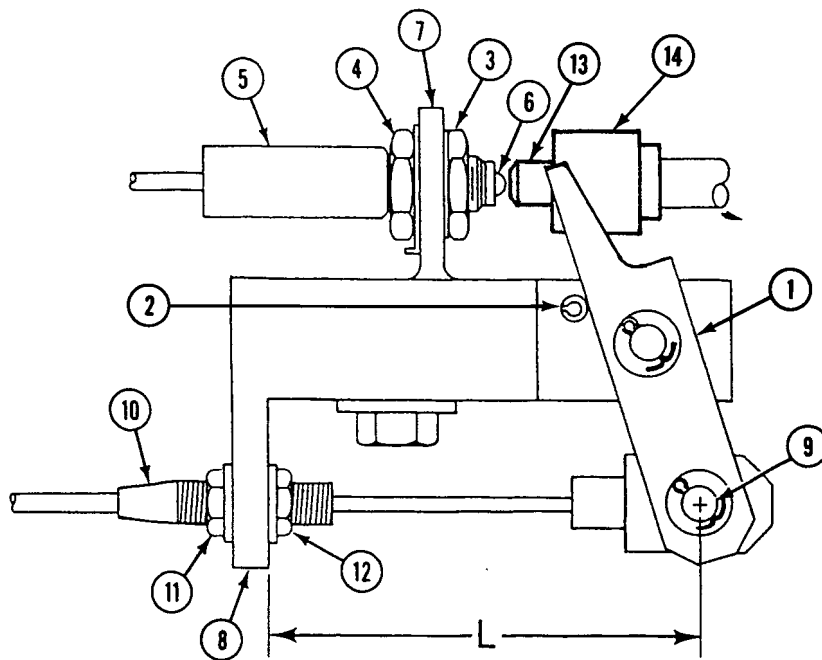

**REPLACE PUSH-PULL CONTROL ASSEMBLY, BRACKET, LINKS, AND PINS
(CABLE-ACTIVATED LOCK) — Continued**

0429 00

ADJUSTMENT

1. Use a 6-inch ruler to measure the distance from bracket housing (8) to center of rod end pin (9).
2. Place transmission controller in SL position.
3. Adjust push-pull control assembly (10) at jamnuts (11) and (12) so that links are 1/2 inch from their retracted position as follows:

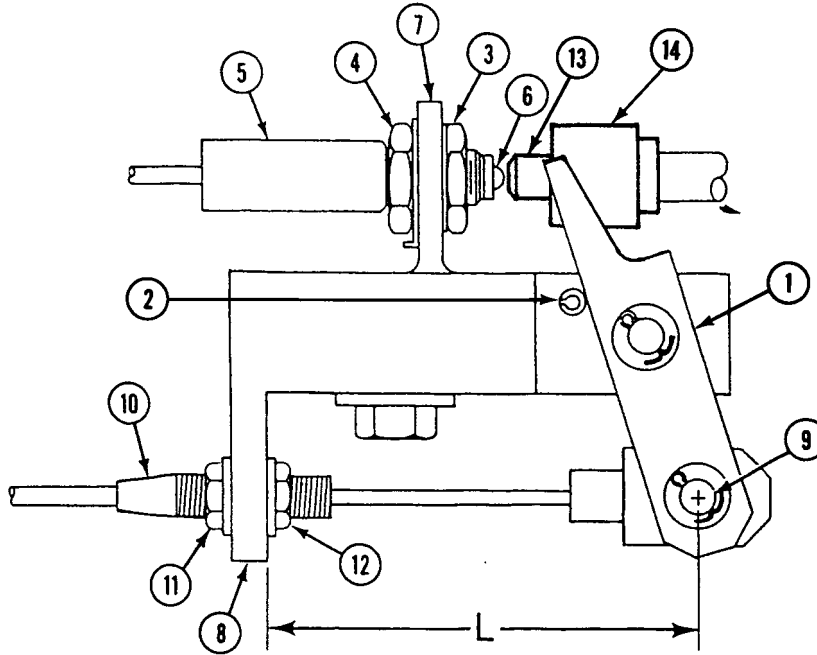

- a. With transmission controller in SL position, measure the distance from bracket (8) to the center of pin (9). Record distance as L1.
- b. Move the transmission controller out of SL position.
- c. Measure the distance from bracket (8) to the center of pin (9). Record distance as L2.
- d. The difference between the measured distances L2 minus L1 must be 1/2 inch \pm 1/32 inch (12.7 mm \pm .8 mm).
- e. Adjust jamnuts (11) and (12) to get 1/2 inch adjustment. Tighten jamnuts.

**REPLACE PUSH-PULL CONTROL ASSEMBLY, BRACKET, LINKS, AND PINS
(CABLE-ACTIVATED LOCK) — Continued**

0429 00

4. Place transmission controller in R position.
5. Install spring (1) on locking pin (2).
6. Install bracket (3) in steering wheel housing (4). Secure with two washers (5) and screws (6). Do not tighten.
7. Turn steering wheel (7) all the way to one side. Slide bracket (3) to the steering wheel (7) until locking pin (2) is flush with the housing (4).

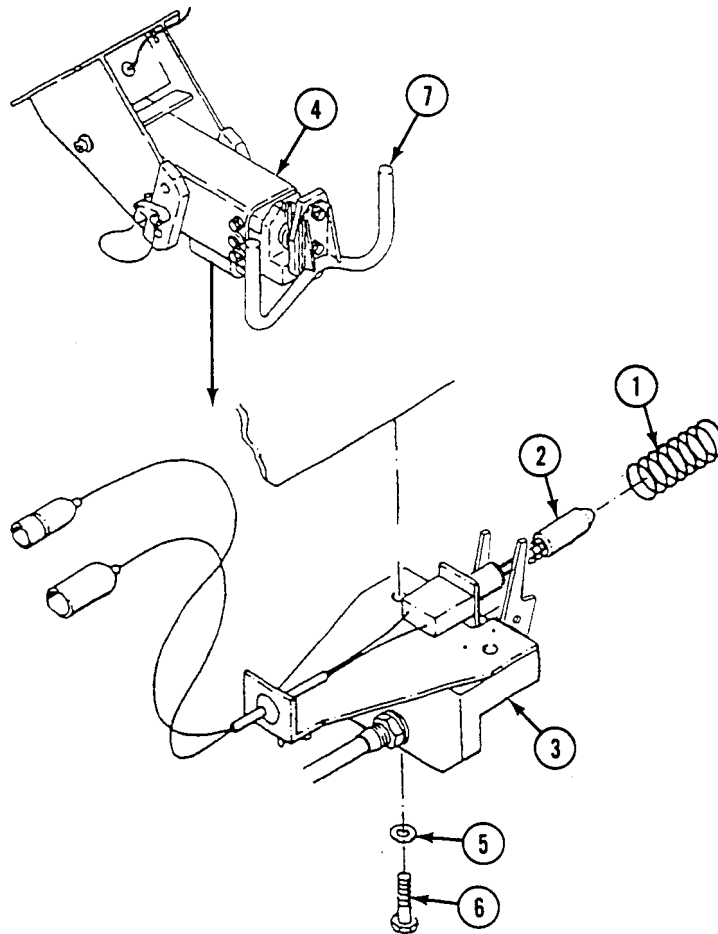

**REPLACE PUSH-PULL CONTROL ASSEMBLY, BRACKET, LINKS, AND PINS
(CABLE-ACTIVATED LOCK) — Continued**

0429 00

8. Turn the steering wheel (7) left and right to insure the locking pin is not interfering with operation.
9. Measure the locking pin (2) to see if it is flush with the steering wheel housing (4). The locking pin must be flush and can have only a negative tolerance. It can be a maximum recess of 1/16 inch (1.6 mm). This measurement is maintained for all positions of the transmission controller except the SL position.

WARNING



With the transmission controller in any range except SL and if the locking pin is protruding from the steering wheel housing any amount, the steering wheel will not turn properly and death of personnel or damage of equipment may occur.

10. Loosen two screws (6) and adjust the bracket (3) until the locking pin is flush or maximum 1/16 inch (1.6 mm) recessed. Tighten two screws (6).

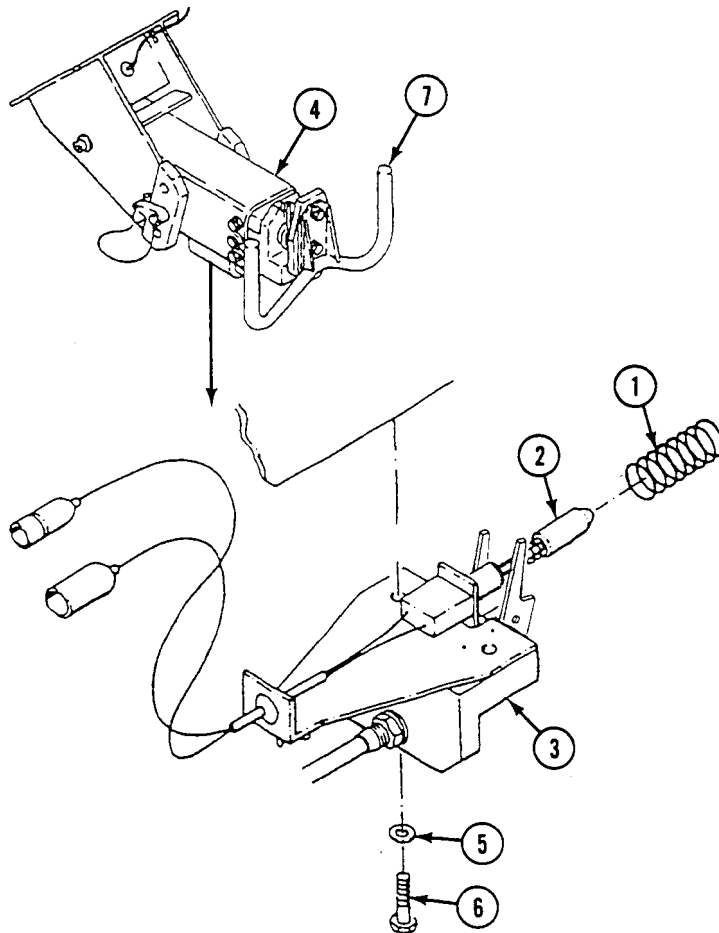

REPLACE PUSH-PULL CONTROL ASSEMBLY, BRACKET, LINKS, AND PINS
(CABLE-ACTIVATED LOCK) — Continued

0429 00

11. Install lead 369A (9) and 368 (10).
12. Secure leads 369A (9) and 368 (10) with two new straps (11) to steering wheel housing (4).

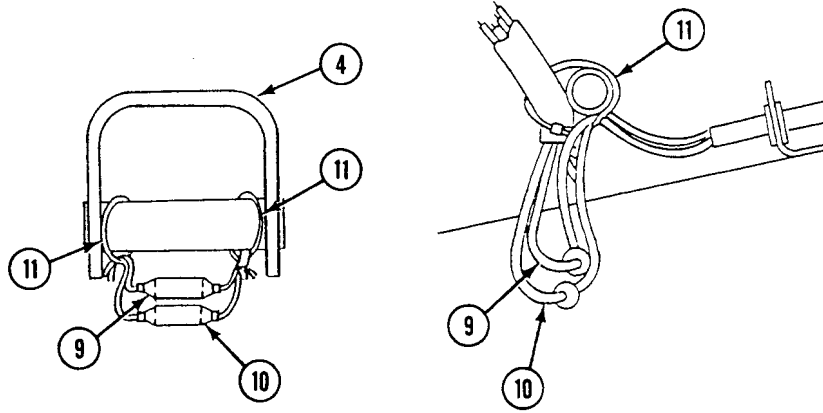

**REPLACE PUSH-PULL CONTROL ASSEMBLY, BRACKET, LINKS, AND PINS
(CABLE-ACTIVATED LOCK) — Continued**

0429 00

13. Rotate steering wheel 30 degrees in either direction. Hold steering wheel in this position.
14. Place transmission controller in SL position.
15. Turn MASTER SWITCH ON (see your -10).
16. Observe that STEERING LOCKED warning light is off (see your -10).
17. If STEERING LOCKED warning light comes on, loosen two screws (1) that secure bracket (2) to steering wheel housing (3).
18. Slide bracket (2) away from steering wheel until STEERING LOCKED warning light goes out.
19. Tighten two screws (1) that secure bracket (2) to steering wheel housing (3).
20. Center steering wheel. Steering wheel should lock.
21. STEERING LOCKED warning light should turn on (see your -10).
22. Turn MASTER SWITCH OFF (see your -10).
23. Place transmission controller in R position (see your -10).
24. Rotate steering wheel in both directions. There should be no interference. If there is, repeat Step 9 and Step 10.

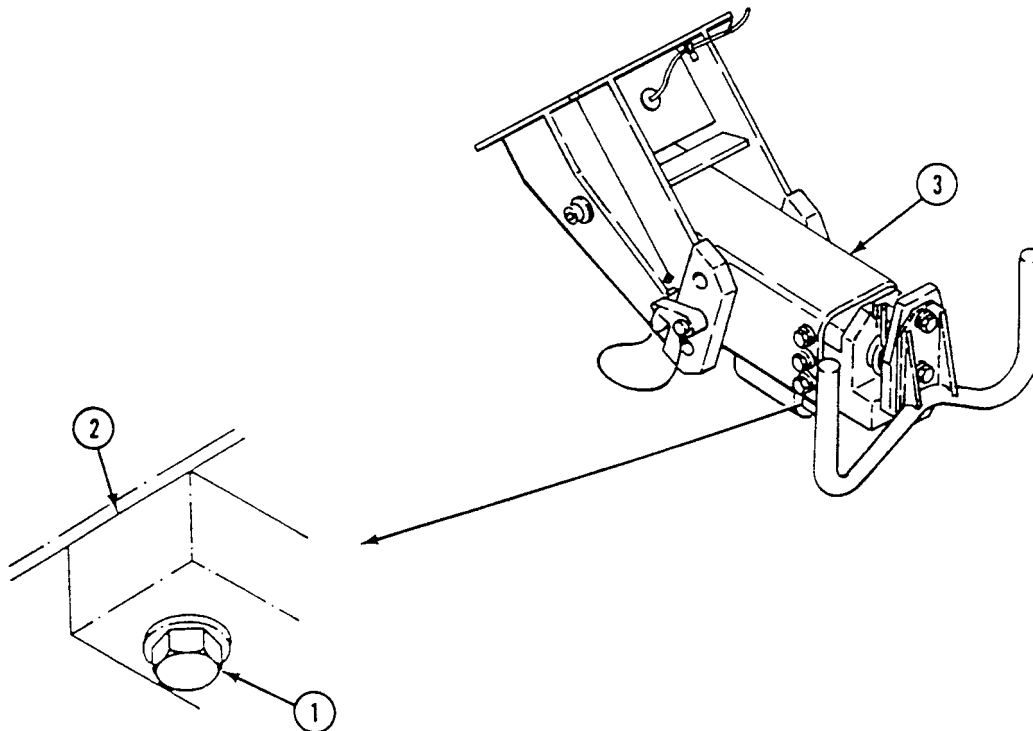
**FOLLOW THROUGH STEPS**

1. Place transmission controller in SL position (see your -10).

END OF TASK

REPLACE STEERING WHEEL LINKAGE

0430 00

THIS WORK PACKAGE COVERS:

Removal (page 0430 00-1).
 Installation (page 0430 00-6).

INITIAL SETUP:

Maintenance Level

Unit

References

See your -10

Tools and Special Tools

General Mechanic's Tool Kit (WP 0926 00, Item 65)
 Torque Wrench (WP 0926 00, Item 82)

Equipment Condition

Engine stopped (see your -10)
 Carrier blocked (see your -10)
 Trim vane lowered (see your -10)
 Power plant access door opened (see your -10)
 Driver's power plant access panel removed
 (see your -10)

Materials/Parts

Locknut (6)
 Lockwasher (2)

Personnel Required

Unit Mechanic

REMOVAL

1. Remove screw (1), washer (2), and locknut (3) that secure link (4) to arm (5). Discard locknut.

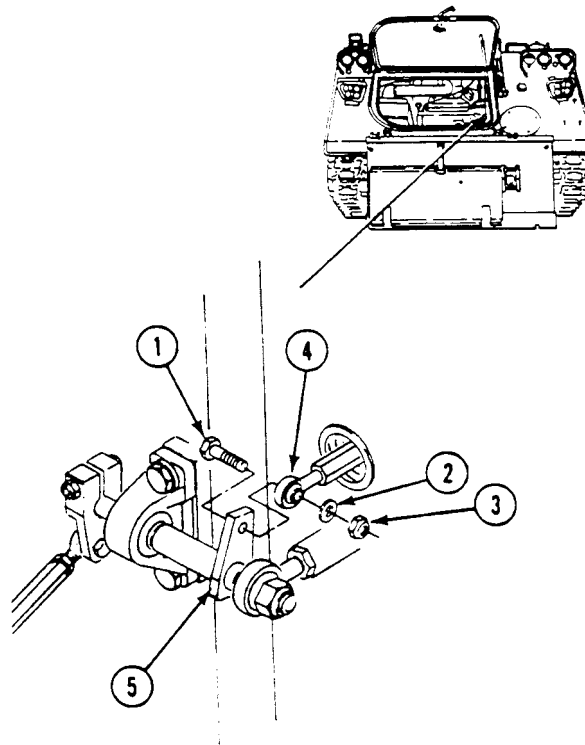

2. Remove screw (6), washer (7), and locknut (8) that secure link (4) to arm (9). Discard locknut.

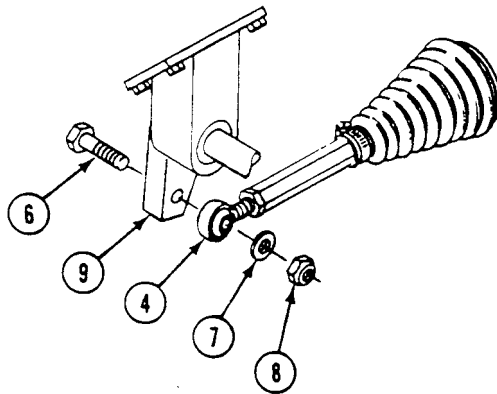
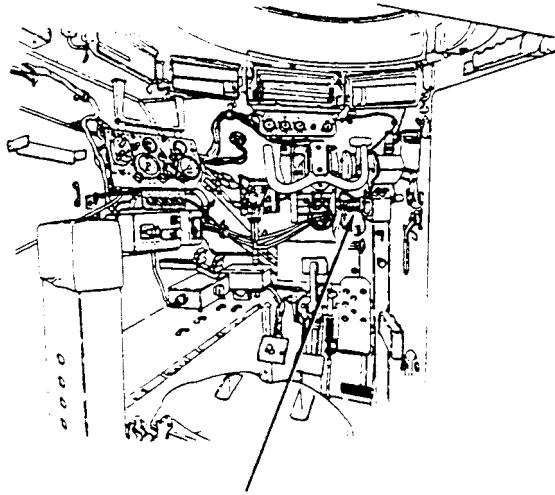

3. Remove link (1) with bellows (2) from hull.
4. Loosen nut (3) on link (1). Remove bearing (4) with nut from link.
5. Loosen clamp (5) and slide bellows (2) and clamp (5) off link (1).

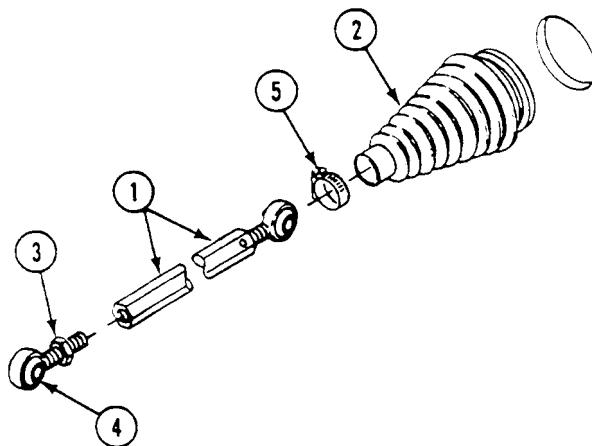

6. Remove locknut (6) and washer (7) from end of shaft (8). Discard locknut.

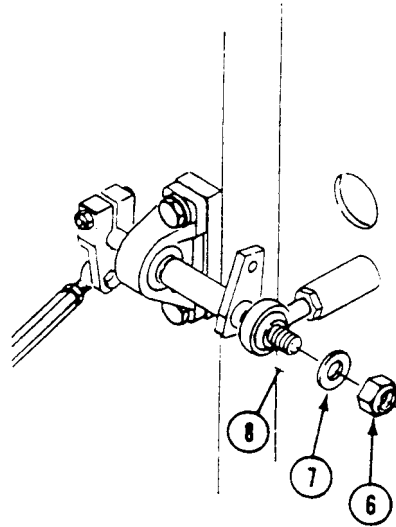

7. Remove screw (9), washer (10), and locknut (11) that secure link (12) to arm (13). Discard locknut.

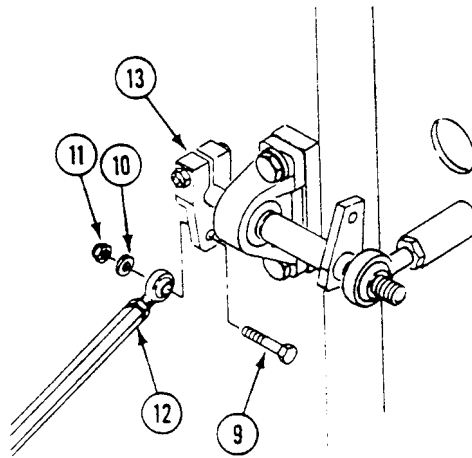

8. Remove screw (14) and locknut (15) that secure arm (13) to shaft (8). Remove arm. Discard locknut.
9. Remove key (16) from shaft (8).

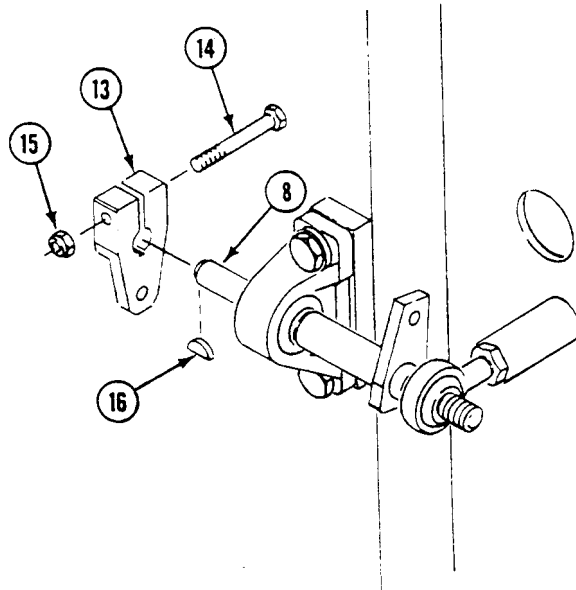

10. Remove two screws (1), two lockwashers (2), and two washers (3) that secure bearing (4) to bulkhead. Discard lockwashers.
11. Remove bearing (4) from shaft (5).
12. Remove shaft (5) from bearing (6).
13. Loosen nut (7) that secures bearing (6) to bulkhead.
14. Remove bearing (6) from mount (8) in bulkhead.

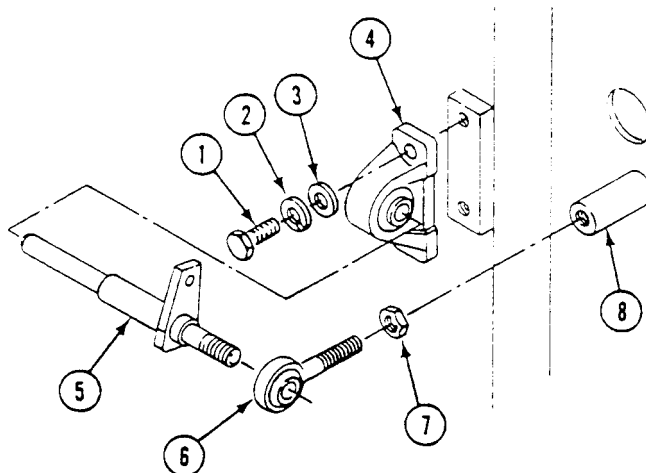

15. Loosen two clamps (9) and remove hose (10) between turbocharger (11) and air cleaner housing (12).

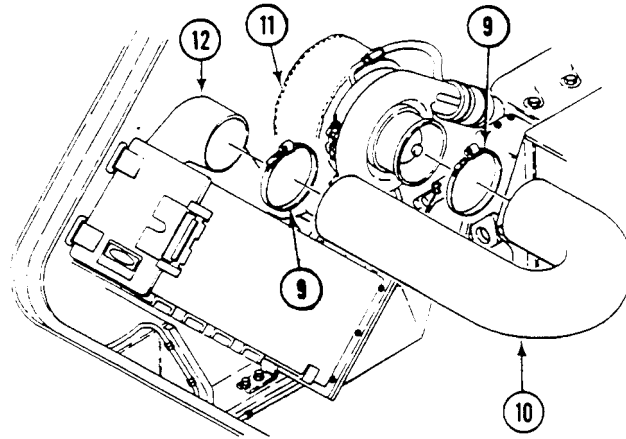

16. Loosen two clamps (13) that secure exhaust elbow (14) on engine. Remove exhaust elbow.

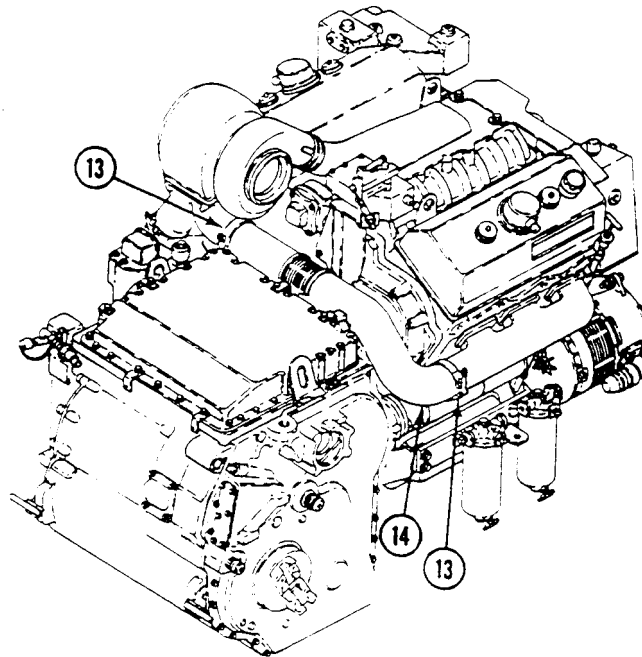

17. Remove screw (15), washer (16), and locknut (17) that secure link (18) to arm (19) on transmission. Remove link. Discard locknut.

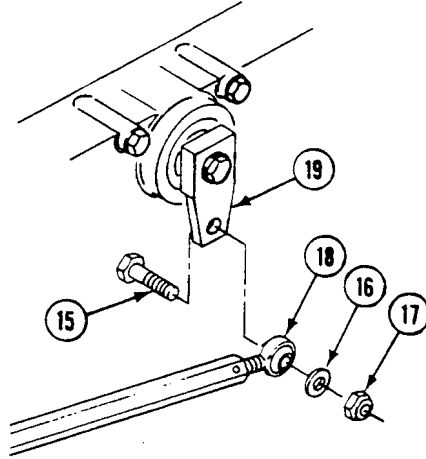

INSTALLATION

1. Secure link (18) with screw (15), washer (16), and new locknut (17) to arm (19) on transmission.

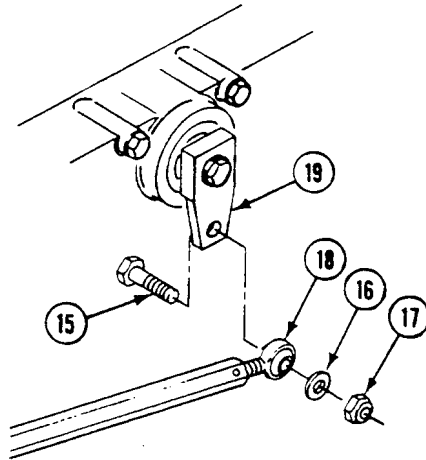

2. Install two clamps (1) and hose (2) between air cleaner housing (3) and turbocharger (4). Tighten clamps.

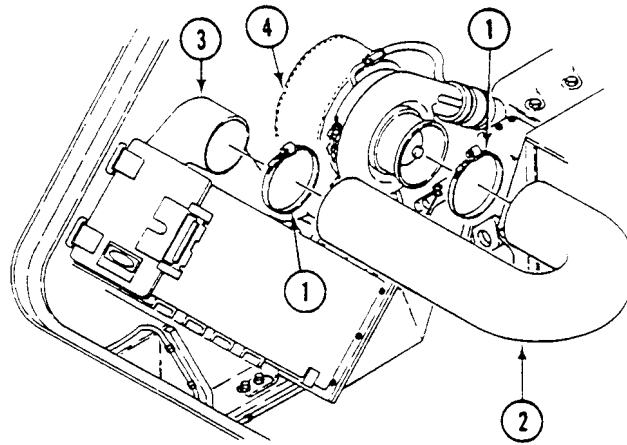

3. Secure exhaust elbow (5) on engine with two clamps (6). Tighten clamps.

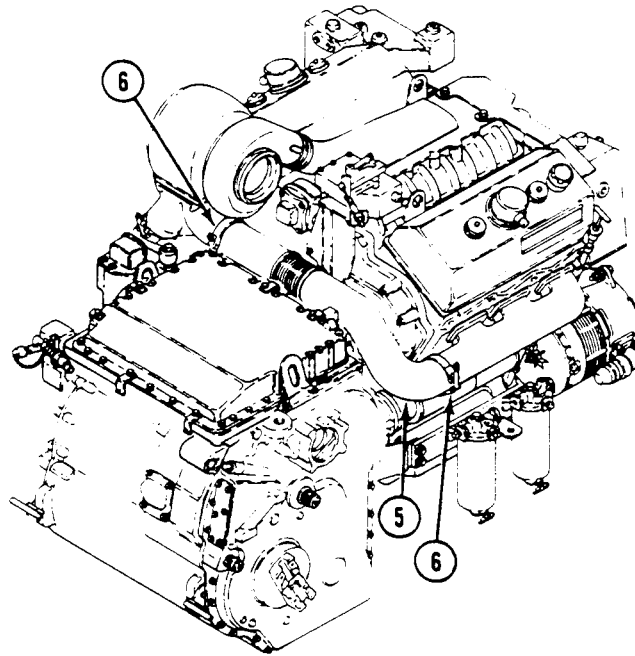

4. Install bearing (7) with nut (8) in mount (9) on bulkhead.
5. Tighten nut (8) on bearing (7).
6. Install shaft (10) into bearing (7)
7. Install other end of shaft (10) into bearing (11).
8. Secure bearing (11) to bulkhead with two washers (12), new lockwashers (13), and screws (14).
9. Install key (15) on shaft (10).

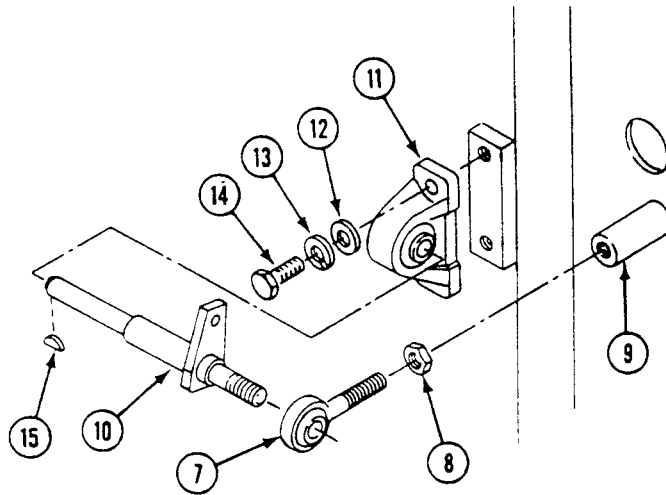

10. Install arm (16) on shaft (10). Align arm with link (17). Secure link on arm with screw (18), washer (19), and new locknut (20). Secure arm (16) with screw (21) and new locknut (22). **TIGHTEN LOCKNUT TO 17-20 LB-FT (23-27 N·m) TORQUE.**

11. Install washer (23) and new locknut (24) on end of shaft (10).

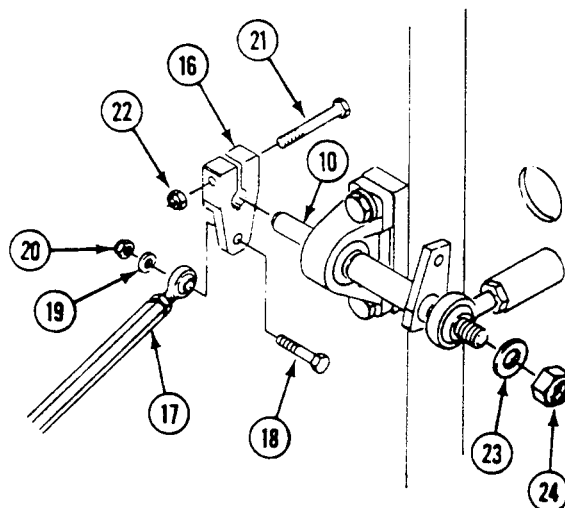

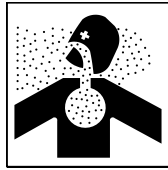
WARNING

Engine exhaust gas is deadly poison. Make sure the bellows is installed properly in engine compartment panel hole.

NOTE

Position small end of bellows away from fixed rod end bearing.

12. Slide bellows (1) and clamp (2) over link (3). Do not tighten clamp until link and bellows are installed.
13. Install bearing (4) and nut (5) on link (3). Tighten nut.
14. Position link (3) with bellows (1) between engine compartment and driver's compartment.

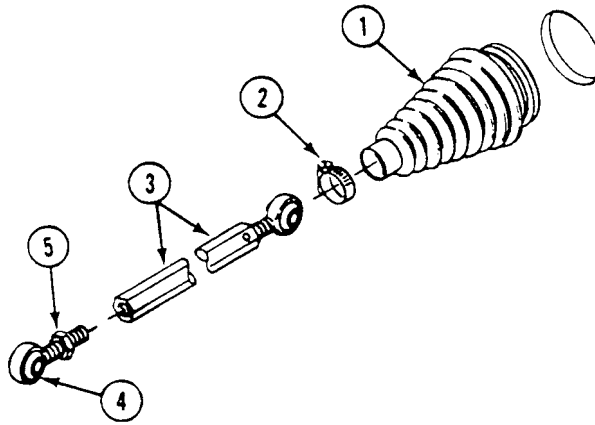

15. Secure link (3) to arm (6) with screw (7), washer (8), and new locknut (9).
16. Secure other end of link (3) to arm (10) with screw (11), washer (12), and new locknut (13).

NOTE

Make sure bellows is correctly installed and seated in hull bulkhead. The bellows keeps engine compartment fumes and/or noise from entering the driver's compartment.

17. Install bellows (1) in driver's bulkhead. Secure small end of bellows with clamp (2).

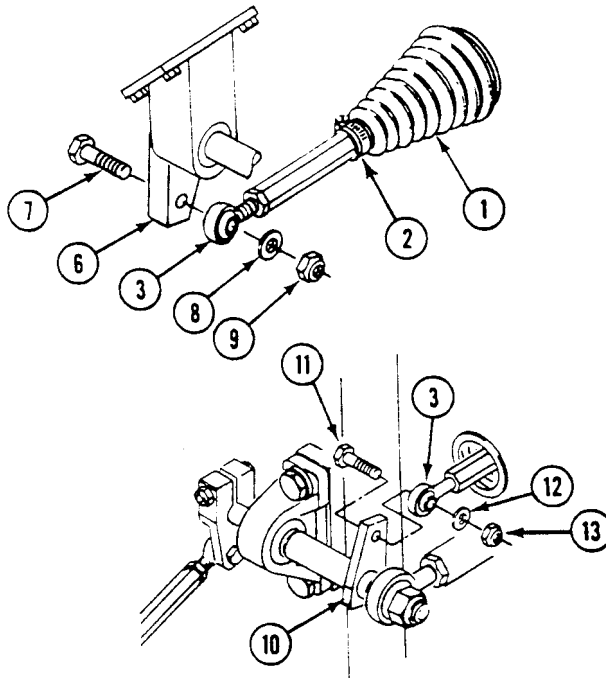

FOLLOW-THROUGH STEPS

1. Adjust steering linkage (WP 0427 00).
2. Install driver's power plant access panel (see your -10).
3. Close power plant access door (see your -10).
4. Raise trim vane (see your -10).

END OF TASK

REPLACE QUICK RELEASE PIN AND LANYARD

0431 00

THIS WORK PACKAGE COVERS:

Removal (page 0431 00-1).
 Installation (page 0431 00-2).

INITIAL SETUP:

Maintenance Level

Unit

Personnel Required

Unit Mechanic

Tools and Special Tools

General Mechanic's Tool Kit (WP 0926 00, Item 65)

References

See your -10

Materials/Parts

Locknut

Equipment Condition

Engine stopped (see your -10)
 Carrier blocked (see your -10)

REMOVAL

1. Remove screw (1), washer (2), locknut (3), and lanyard (4) from bracket (5). Discard locknut.
2. Remove quick release pin (6) from bracket (5).
3. Remove lanyard (4) from quick release pin (6).

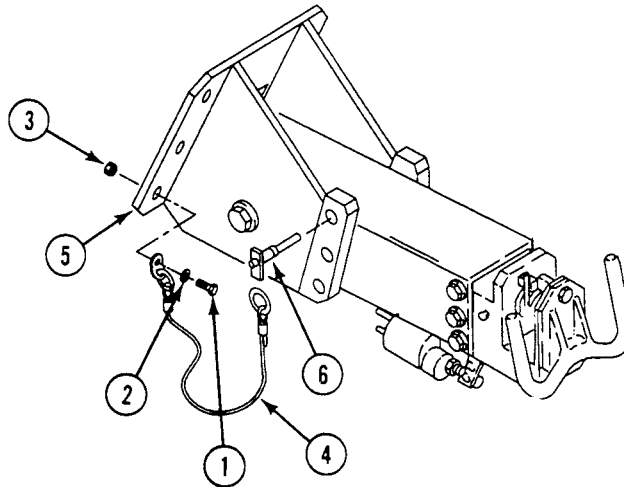

INSTALLATION

1. Install lanyard (4) on quick release pin (6). Insert pin (6) in bracket (5) and support.
2. Install lanyard (4), washer (2), screw (1), and new locknut (3) in bracket (5).

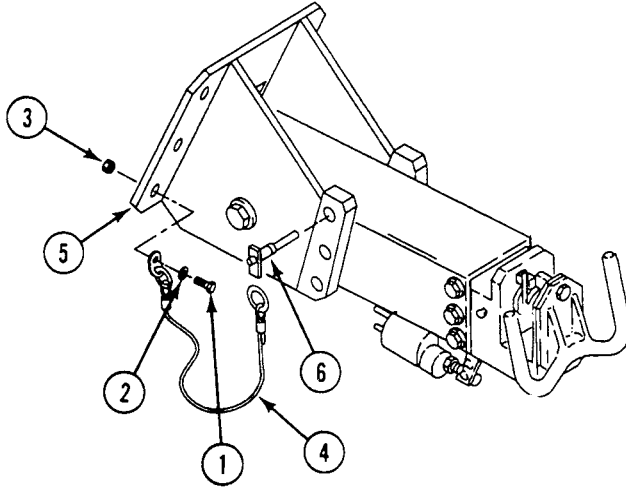
**END OF TASK**

REPLACE STEERING SUPPORT, BRACKETS, AND SHAFT

0432 00

THIS WORK PACKAGE COVERS:

Removal (page 0432 00-1).
 Installation (page 0432 00-6).

INITIAL SETUP:

Maintenance Level

Unit

Personnel Required

Unit Mechanic

Tools and Special Tools

General Mechanic's Tool Kit (WP 0926 00, Item 65)
 Retaining Ring Pliers Set (WP 0926 00, Item 32)
 Torque Wrench (WP 0926 00, Item 82)

References

See your -10

Materials/Parts

Grommet
 Locknut (3)
 Lockwasher (10)
 Locknut (3)
 Retaining ring
 Spring pin (4)

Equipment Condition

Engine stopped (see your -10)
 Carrier blocked (see your -10)
 Solenoid/bracket removed (WP 0428 00) or control
 assembly/bracket removed (WP 0429 00)
 Steering wheel linkage removed (WP 0430 00)

REMOVAL

1. Remove six screws (1) and washers (2) that secure steering wheel assembly (3) to support (4). Remove steering wheel assembly.
2. Remove woodruff key (5) from shaft (6).

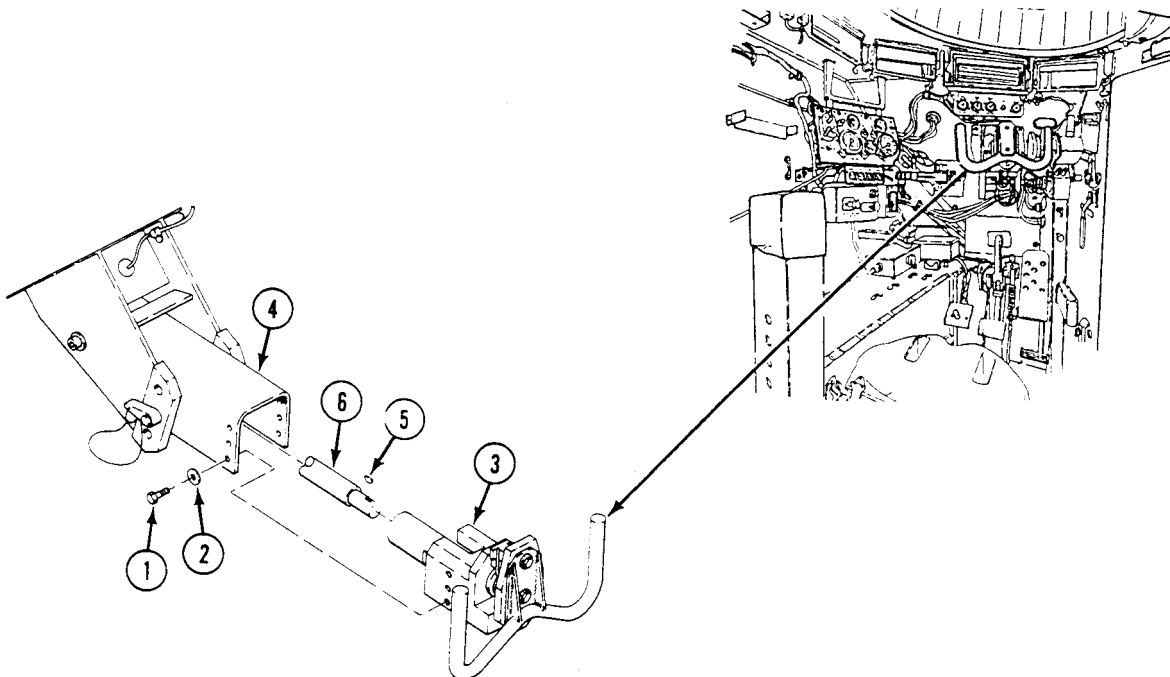

REPLACE STEERING SUPPORT, BRACKETS, AND SHAFT — Continued

0432 00

3. Remove screw (1), washer (2), and nut (3) that secure lanyard (4) to bracket (5). Remove pin (6).
4. Remove two socket head screws (7), washers (8), and locknuts (9) that secure support (10) to bracket (5). Remove support from carrier. Discard locknuts.
5. Remove three screws (11), washers (12), clamps (13), and nuts (14) that secure cable (15) to support (10) and bracket (5).
6. Pull cable (15) and grommet (16) from bracket (5). Discard grommet.

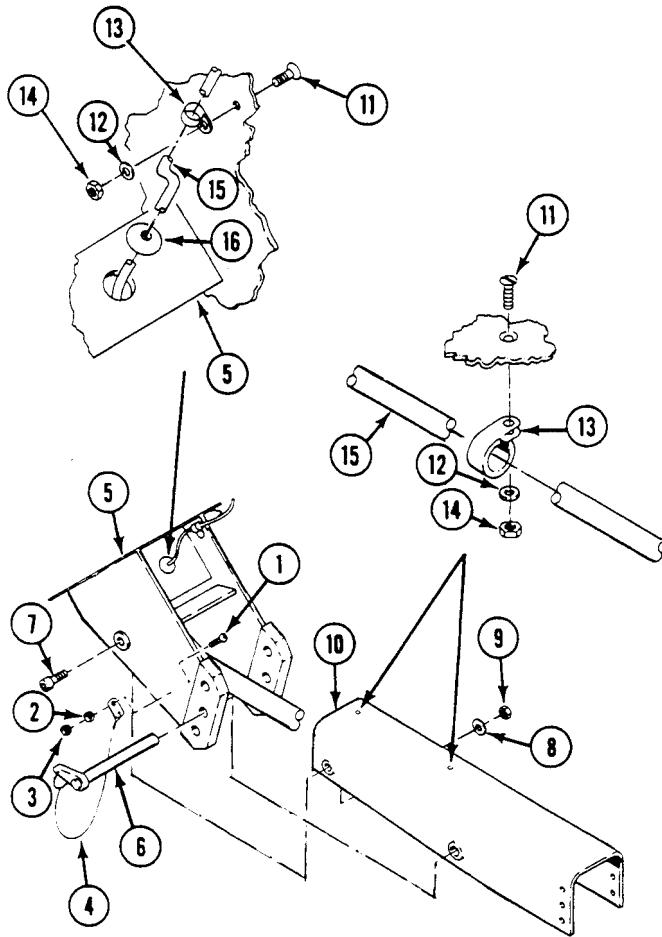

REPLACE STEERING SUPPORT, BRACKETS, AND SHAFT — Continued

0432 00

7. Remove six screws (17), washers (18), lockwashers (19) and ground wire (20) from bracket (5) and bulkhead. Remove bracket. Discard lockwashers.
8. Remove four screws (21), washers (22), and lockwashers (23) that secure bracket (24) and shaft to bulkhead. Remove bracket with shaft. Discard lockwashers.

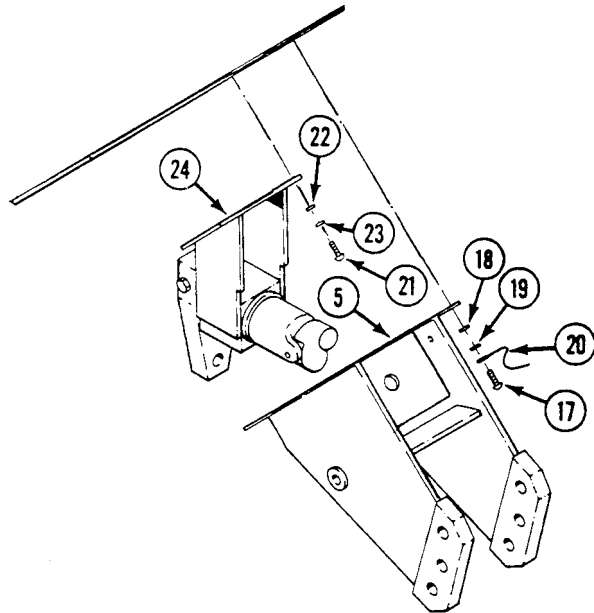

9. Remove locknut (1) on screw (2) that secures arm (3) on shaft (4). Remove arm. Discard locknut.
10. Remove woodruff key (5) and washer (6) from shaft (4).

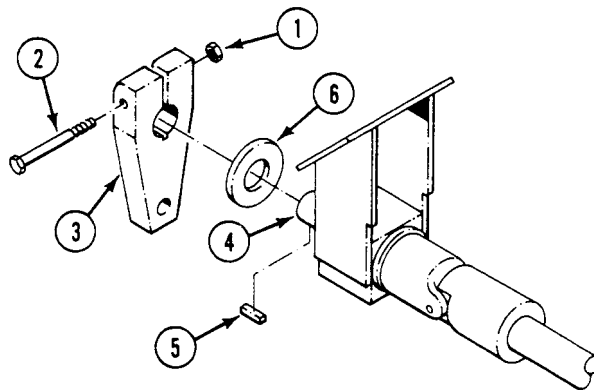

REPLACE STEERING SUPPORT, BRACKETS, AND SHAFT — Continued

0432 00

11. Remove shaft (4) from bracket (7).
12. Remove washer (8) from shaft (4).
13. Remove lube fitting (9) from bracket (7).

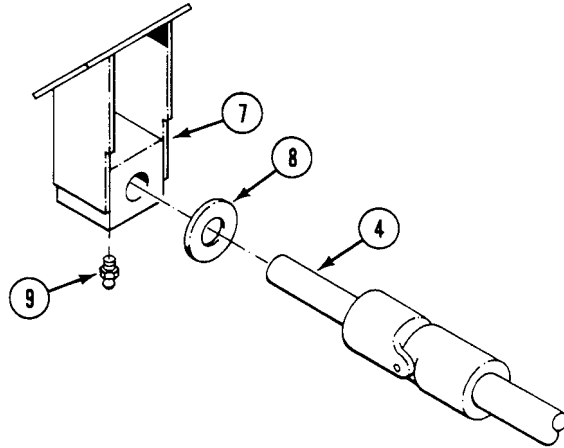

14. Remove two screws (10) and washers (11) that secure steering wheel (12) and spacer (13) to shaft (14). Remove retainer (15).
15. Remove screw (16) and nut (17).

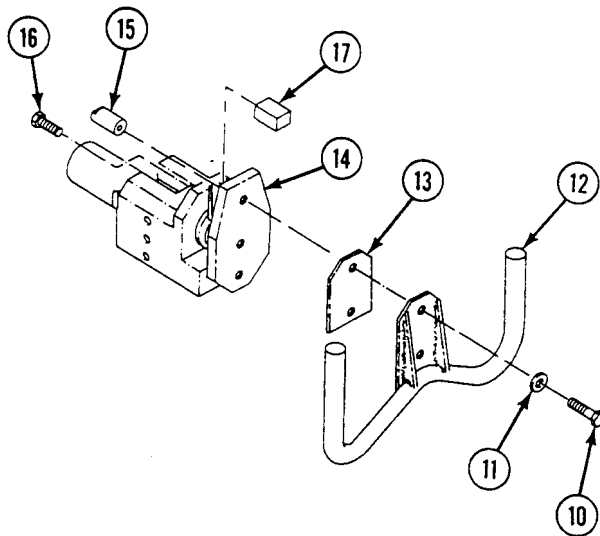

REPLACE STEERING SUPPORT, BRACKETS, AND SHAFT — Continued

0432 00

16. Place housing (1) in vise and drive spring pin (2) from U-joint (3). Discard spring pin.
17. Remove U-joint (3) and woodruff key (4) from shaft (5).
18. Remove retaining ring (6) and washer (7) from shaft (5). Discard retaining ring.
19. Remove shaft (5) from housing (1).
20. Remove washer (8) and spring (9) from shaft (5).
21. Remove lube fitting (10) from housing (1).

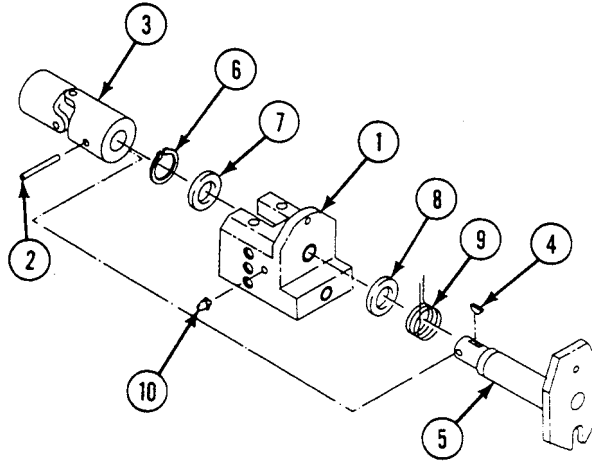

INSTALLATION

1. Install lube fitting (10) on housing (1).
2. Install spring (9) and washer (8) on shaft (5).
3. Install shaft (5) in housing (1).

NOTE

Make sure retaining ring seats in groove on shaft.

4. Install washer (7) and new retaining ring (6) on shaft (5).
5. Install woodruff key (4) on shaft (5).
6. Install shaft (5) in U-joint (3). Secure with new spring pin (2).

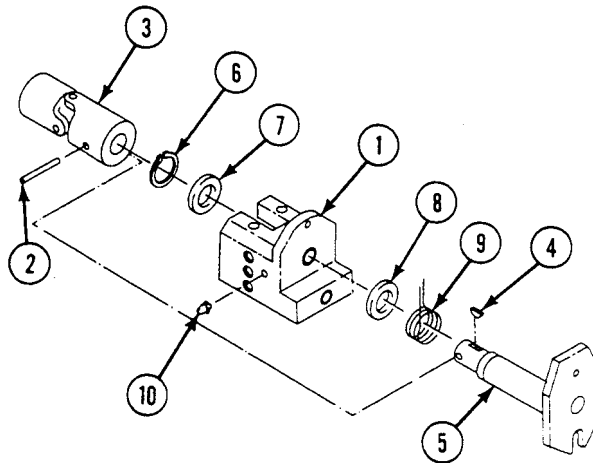

NOTE

Make sure nut is between spring fingers and is properly leveled when installed on housing.

7. Install screw (11) and nut (12).
8. Install spacer (13) and steering wheel (14) on shaft (5). Secure with screw (15) and washer (16).

NOTE

When installing retainer, install as high as possible on steering wheel shaft.

9. Install screw (17) and washer (18) through steering wheel (14) and spacer (13) and secure retainer (19).
10. Check steering wheel (14) for smooth operation by turning fully in both directions.

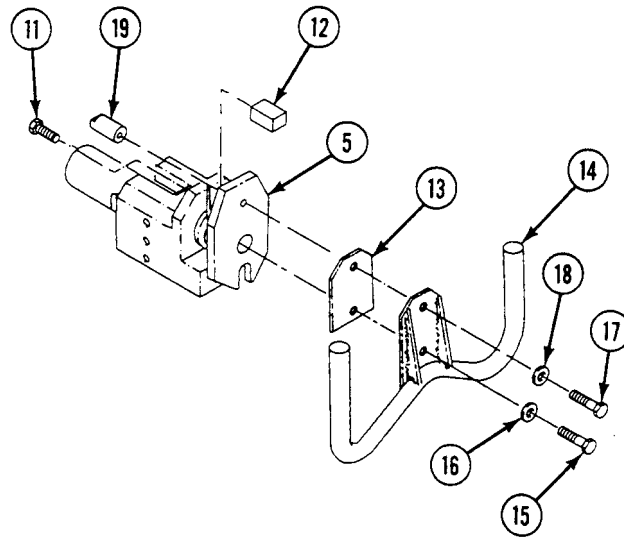

11. Install washer (1) on shaft (2) and insert shaft through bracket (3).
12. Install lube fitting (4) in bracket (3).

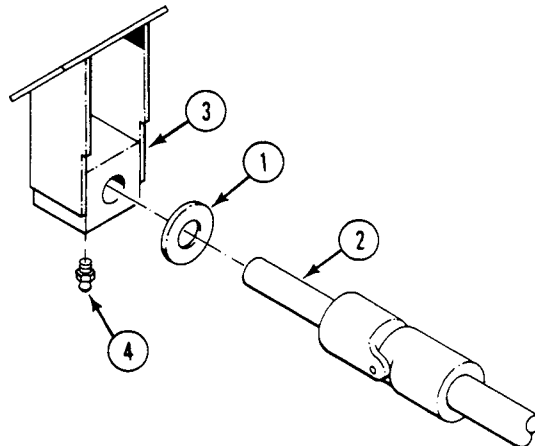

13. Install washer (5) on shaft (2).
14. Install woodruff key (6) on shaft (2).

NOTE

When installing arm on shaft, make sure chamfered edge on arm faces front of vehicle.

15. Install arm (7) on shaft (2) and secure with screw (8) and new locknut (9). TIGHTEN LOCKNUT TO 17-20 LB-FT (23-27 N·m) TORQUE.

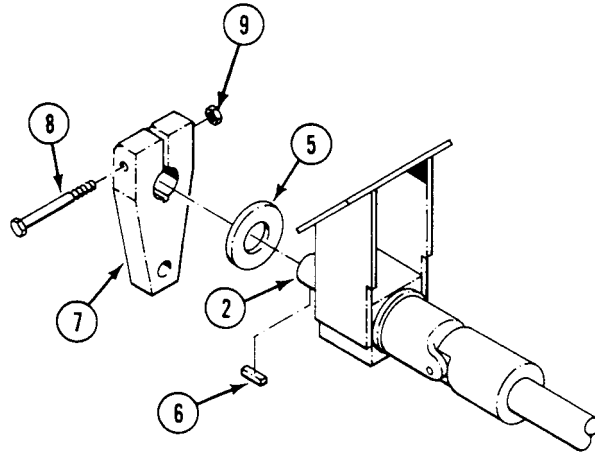

REPLACE STEERING SUPPORT, BRACKETS, AND SHAFT — Continued

0432 00

16. Install four screws (10), washers (11), and new lockwashers (12) and secure bracket (3) with shaft (2) to bulkhead.
17. Guide shaft (2) through bracket (13). Secure bracket and ground lead (14) to bulkhead with six screws (15), new lockwashers (16), and washers (17).

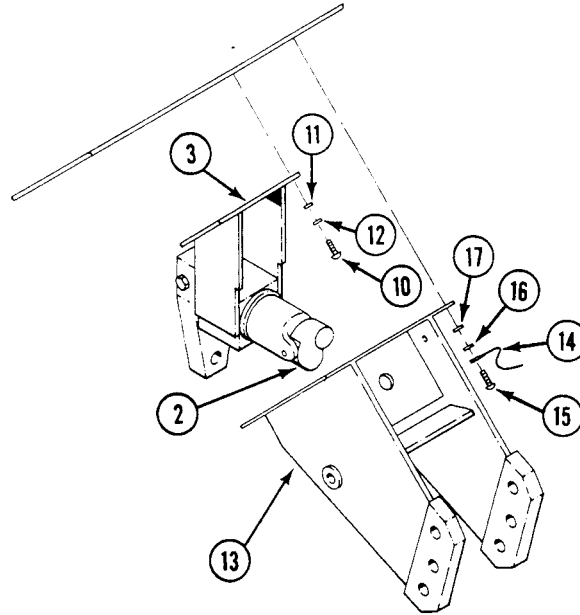

18. Install cable (1) and new grommet (2) in bracket (3). Secure cable to bracket with screw (4), clamp (5), washer (6), and nut (7).
19. Install cable (1) in support (8) and secure with two screws (9), clamps (10), washers (11), and nuts (12).
20. Guide shaft (13) through support (8), and install support (8) on bracket (3). Secure with two screws (14), washers (15), and new locknuts (16).
21. Install pin (17) through bracket (3) and support (8). Secure support in the upper position on the bracket.
22. Install lanyard (18) on bracket (3) and secure with screw (19), washer (20), and nut (21).
23. Install woodruff key (22) on shaft (13).
24. Align woodruff key (22) and install steering wheel assembly (23) on shaft (13).

25. Secure steering wheel assembly (23) in support (8) with six screws (24) and washers (25).

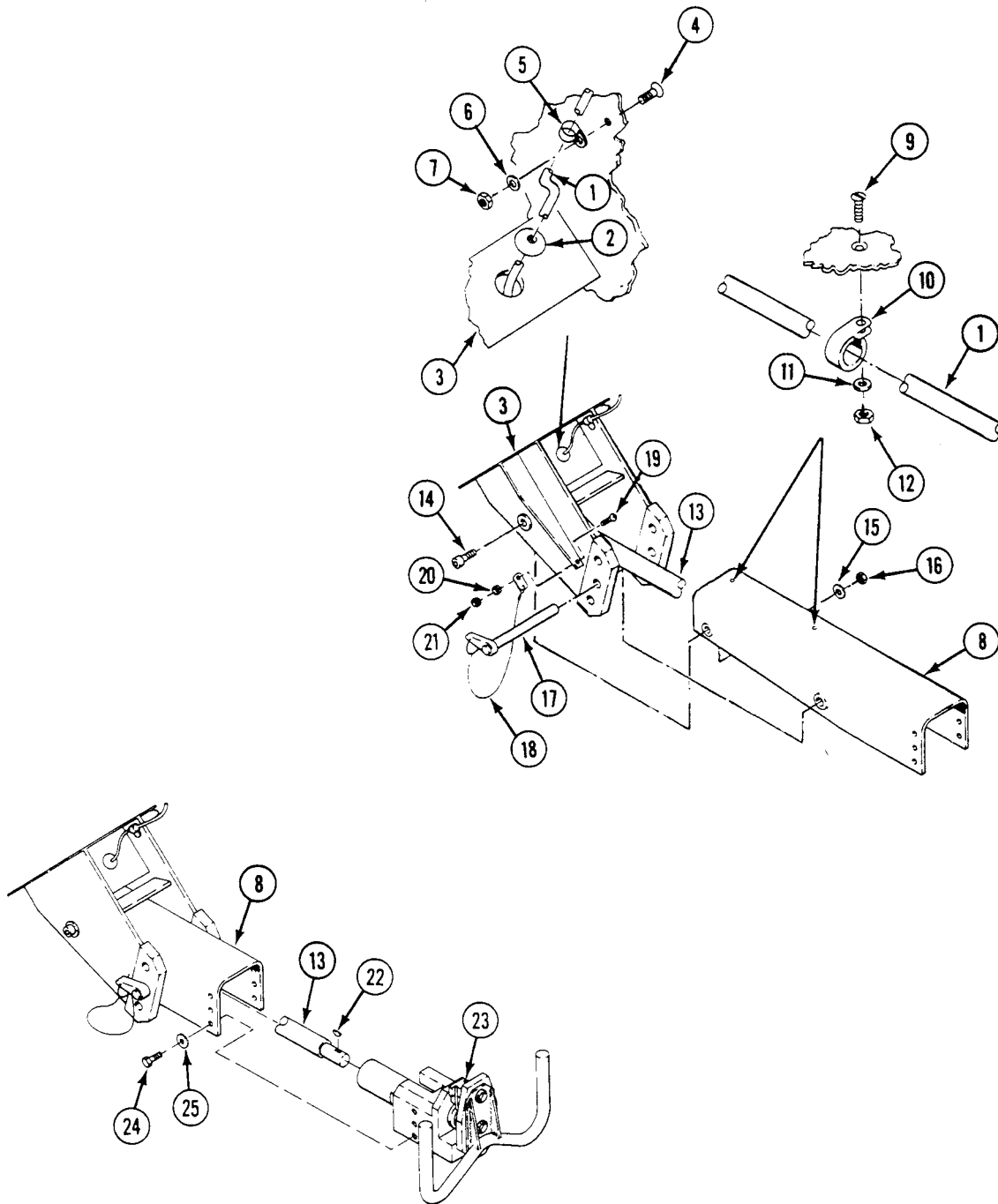

FOLLOW-THROUGH STEPS

1. Install and adjust solenoid/bracket (WP 0428 00) or control assembly/bracket (WP 0429 00).
2. Install steering wheel linkage (WP 0430 00).

END OF TASK

CHAPTER 15

UNIT MAINTENANCE INSTRUCTIONS
FOR TOWING ATTACHMENTS

WORK PACKAGE INDEX

<u>Title</u>	<u>Sequence No.</u>
■ REPLACE TOWING PINTLE.....	0433 00
■ REPAIR TOWING PINTLE.....	0434 00

REPLACE TOWING PINTLE

0433 00

THIS WORK PACKAGE COVERS:

Removal (page 0433 00-1).
 Installation (page 0433 00-2).

INITIAL SETUP:

Maintenance Level

Unit

References

See your -10
 (WP 0155 00)

Tools and Special Tools

General Mechanic's Tool Kit (WP 0926 00, Item 65)

Equipment Condition

Engine stopped (see your -10)
 Carrier blocked (see your -10)

Materials/Parts

Grease (WP 0928 00, Item 12)
 Cotter pin
 Preformed packing

Personnel Required

Unit Mechanic

REMOVAL

NOTE

Do not perform this task if carrier is equipped with tow pintle extender kit.

If carrier is equipped with extender kit, go to (WP 0811 02).

1. Remove cotter pin (1), nut (2), and washer (3) that secure pintle (4) to ramp (5). Discard cotter pin.
2. Remove pintle (4) and preformed packing (6) from ramp (5). Discard packing.

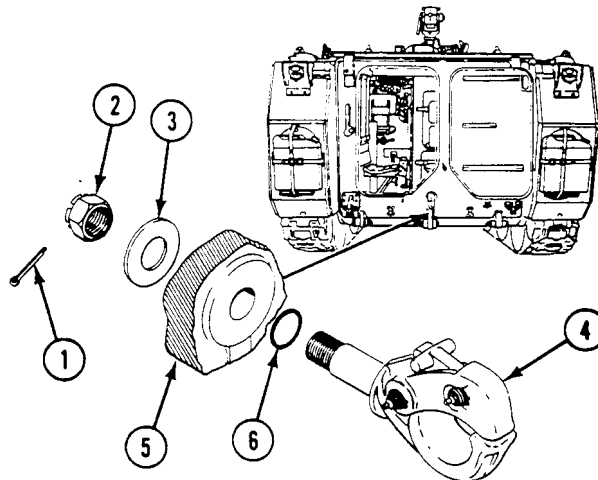

INSTALLATION

1. Install new preformed packing (6) on pintle shaft.
2. Lube shaft of pintle with grease (WP 0155 00).

NOTE

Pintle must turn freely on ramp after installation.

3. Install pintle (4) on ramp (5). Secure with washer (3), nut (2), and new cotter pin (1).

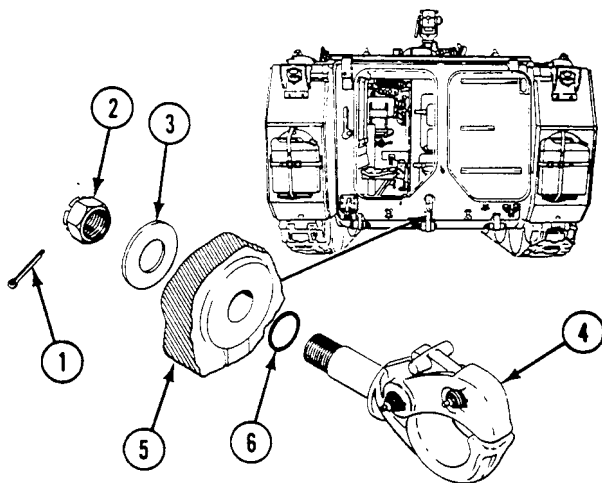
**END OF TASK**

REPAIR TOWING PINTLE

0434 00

THIS WORK PACKAGE COVERS:

- Disassembly (page 0434 00-1).
- Assembly (page 0434 00-2).

INITIAL SETUP:

Maintenance Level
Unit

References
See your -10

Tools and Special Tools
General Mechanic's Tool Kit (WP 0926 00, Item 65)

Equipment Condition

Materials/Parts
Cotter pin

Personnel Required
Unit Mechanic

Pintle removed from carrier (WP 0433 00), or pintle removed from extender assembly (WP 0811 02)

Pintle lock open (see your -10)

DISASSEMBLY

1. Remove lube fitting (1) from pin (2).
2. Remove two retaining rings (3) from pin (2).
3. Remove pin (2) from lock (4) and hook (5).
4. Remove lube fitting (6) from pin (7).
5. Remove two retaining rings (8) from pin (7).
6. Remove pin (7) from latch (9) and lock (4).
7. Remove latch (9) and spring (10) from lock (4).
8. Remove screw (11) and chain (12) from hook (5).
9. Remove cotter pin (13) and S-hook (14) from chain (12).

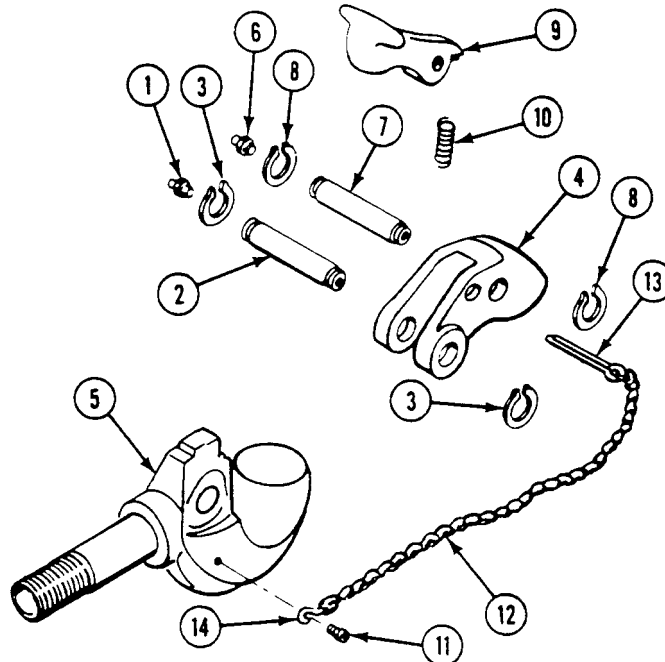

ASSEMBLY

NOTE

Lock (4) and pin (2) are not available as repair parts.

1. Install new cotter pin (13) and S-hook (14) on chain (12).
2. Secure chain (12) on hook (5) with screw (11).
3. Install spring (10) and latch (9) in lock (4).
4. Install pin (7) in lock (4) through latch (9). Secure with two retaining rings (8).
5. Install lube fitting (6) in pin (7).
6. Install lock (4) on hook (5). Secure with pin (2) and two retaining rings (3).
7. Install lube fitting (1) in pin (2).
8. Lube two fittings (1) and (6) (WP 0155 00).

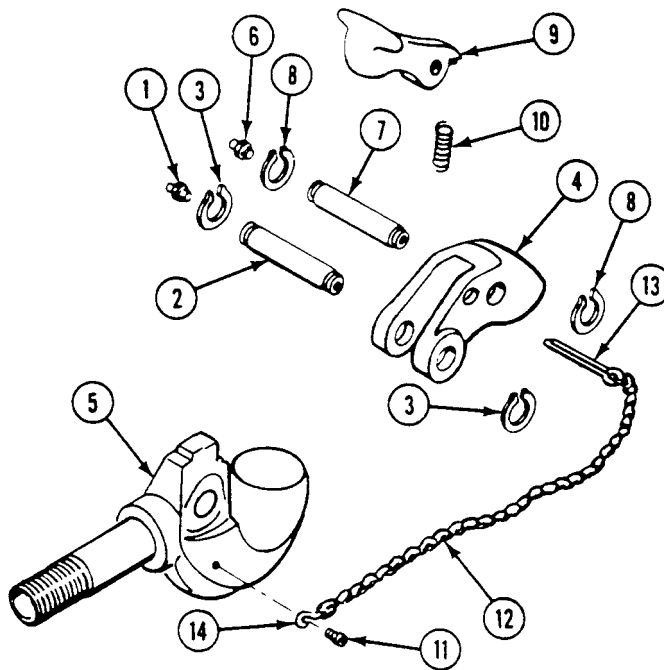

FOLLOW-THROUGH STEPS

1. Install pintle on carrier (WP 0433 00), or on tow pintle extender assembly (WP 0811 02).
2. Close pintle lock (see your -10).

END OF TASK

CHAPTER 16

UNIT MAINTENANCE INSTRUCTIONS
FOR SHOCK ABSORBERS

WORK PACKAGE INDEX

<u>Title</u>	<u>Sequence No.</u>
REPLACE SHOCK ABSORBER.....	.0435 00
REPLACE SHOCK ABSORBER MOUNT.....	.0436 00
REPLACE SHOCK ABSORBER PIN.....	.0437 00

REPLACE SHOCK ABSORBER

0435 00

THIS WORK PACKAGE COVERS:

- Removal (page 0435 00-1).
- Installation (page 0435 00-4).

INITIAL SETUP:

Maintenance Level

Unit

Personnel Required

Unit Mechanic

Tools and Special Tools

- General Mechanic's Tool Kit (WP 0926 00, Item 65)
- Shock Absorber Tool (WP 0926 00, Item 67)
- Torque Wrench (WP 0926 00, Item 85)

References

See your -10

Materials/Parts

- Wiping rag (WP 0928 00, Item 65)
- Cotter pin (2)
- Outer seal
- Inner seal

Equipment Condition

- Carrier on level surface
- Engine stopped (see your -10)
- Carrier blocked (see your -10)
- Track shroud and covers removed (WP 0438 00)
- Road wheel for respective shock absorber removed (WP 0426 00)

REMOVAL

1. Remove blocks used to keep carrier from moving (see your -10).

WARNING

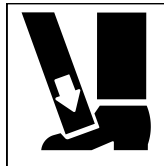

You can be hurt if road wheel lifter slips while road arm is being lowered. Stand clear.

2. Start engine (see your -10). Place range selector in RANGE 1. Slowly drive carrier forward off lifter. Remove lifter.

WARNING



Failure to set the parking brake and block the road wheels can allow the carrier to move and could result in injury or death. Always set the parking brake and block road wheels before working on the carrier.

3. Block carrier (see your -10).

4. Remove two cotter pins (1), nuts (2), and shouldered washers (3) from shock absorber (4). Discard cotter pins.

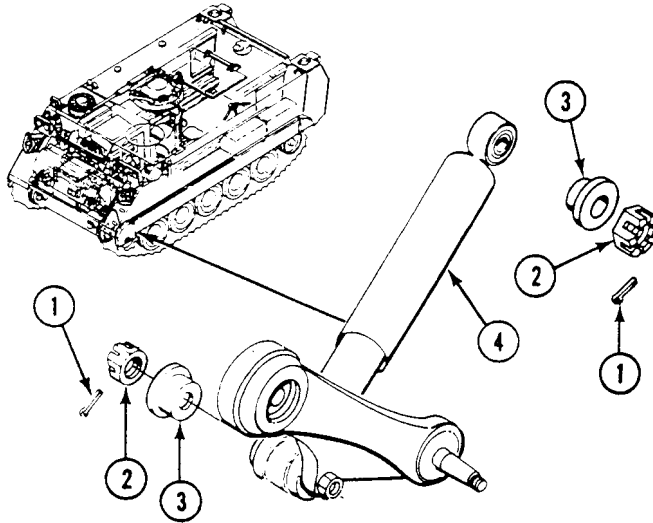

5. Position shock absorber tool on hull mounting bracket (1). Hit tool with heavy hammer to loosen upper end of shock absorber (2).

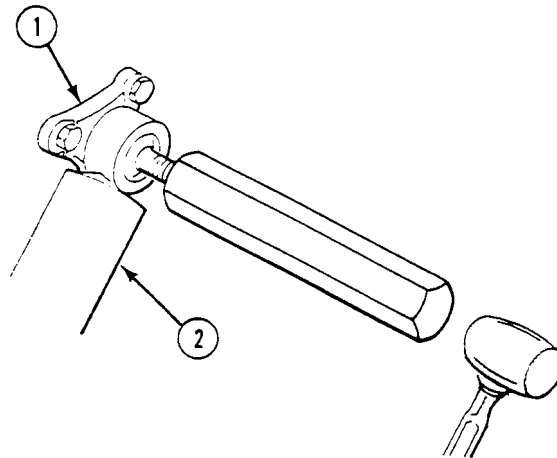

REPLACE SHOCK ABSORBER — Continued

0435 00

6. Position shock absorber tool on road wheel support arm pin (3). Hit tool with heavy hammer to loosen lower end of shock absorber (2).
7. Remove shock absorber (2) and seals (4) and (5) from support arm pin (3). Discard seals.

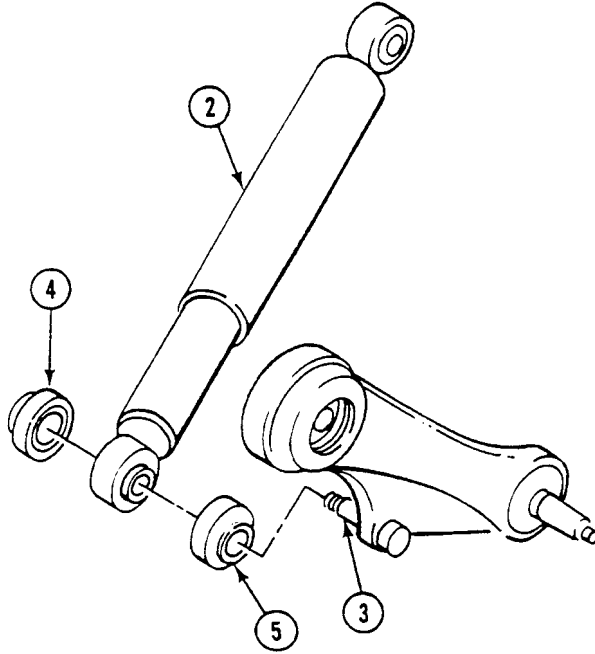

INSTALLATION

1. Install new inner seal (5) on road wheel support arm pin (3).

NOTE

Exercise new shock absorber to the fully extended position and move shock absorber back and forth several times until resistance can be felt throughout the entire length of the stroke.

Make sure shock absorber is installed with large end of bearings installed first.

2. Install shock absorber (2), new outer seal (4), and shouldered washer (6) on support arm pin (3).
3. Install shock absorber (2) and shouldered washer (6) on hull bracket (7).
4. Secure shock absorber (2) with two nuts (8).
5. Tighten two nuts (8) to 60-80 lb-ft (81-108 N.m.) torque.
6. Secure two nuts (8) with two new cotter pins (9). If hole through mount and notches in nut (8) do not align, tighten nut enough to make holes align, then insert new cotter pins (9).

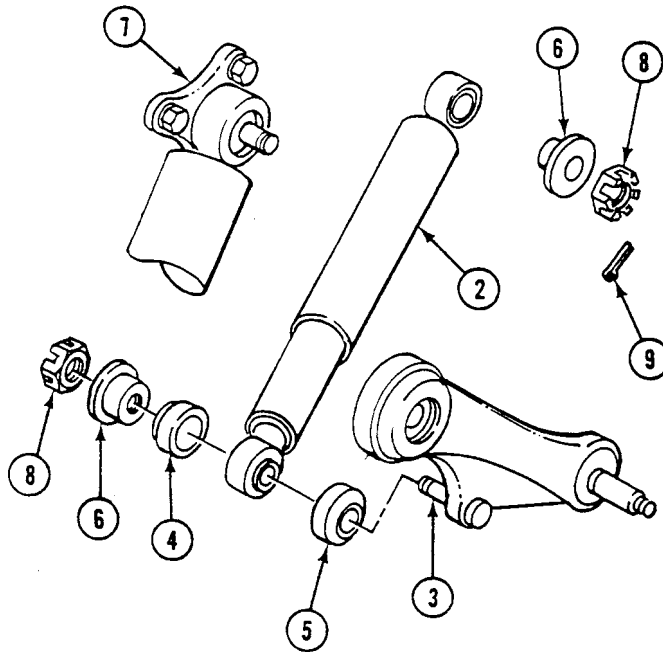

7. Place lifter (1) under road wheel arm (2). Keep lower tips of lifter in track link just rearward of space of roadwheel to be installed.

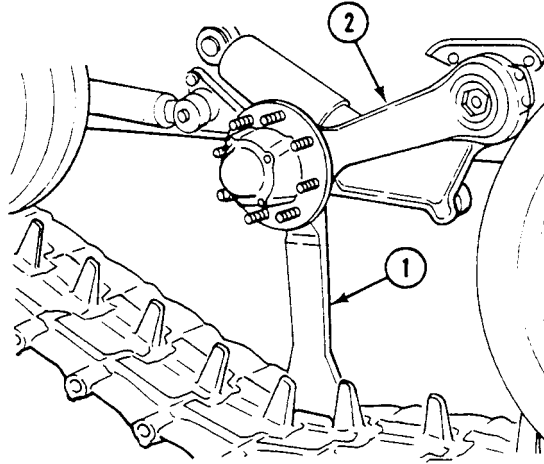
**FOLLOW-THROUGH STEPS**

1. Install road wheel (WP 0426 00).
2. Install track shroud and covers (WP 0438 00).
3. Remove blocks used to keep carrier from moving (see your -10).
4. Road test carrier to check that shock absorber is installed right (WP 0155 00).

END OF TASK

REPLACE SHOCK ABSORBER MOUNT

0436 00

THIS WORK PACKAGE COVERS:

Removal (page 0436 00-1).
 Installation (page 0436 00-2).

INITIAL SETUP:

Maintenance Level

Unit

References

See your -10

Tools and Special Tools

General Mechanic's Tool Kit (WP 0926 00, Item 65)
 Torque Wrench (WP 0926 00, Item 85)

Equipment Condition

Carrier on level surface
 Engine stopped (see your -10)
 Carrier blocked (see your -10)
 Track shroud and covers removed (WP 0438 00)
 Respective road wheel removed (WP 0426 00)
 Respective shock absorber removed (WP 0435 00)

Personnel Required

Unit Mechanic

REMOVAL

1. Remove three screws (1) from shock absorber mount (2).
2. Remove mount (2) from hull.

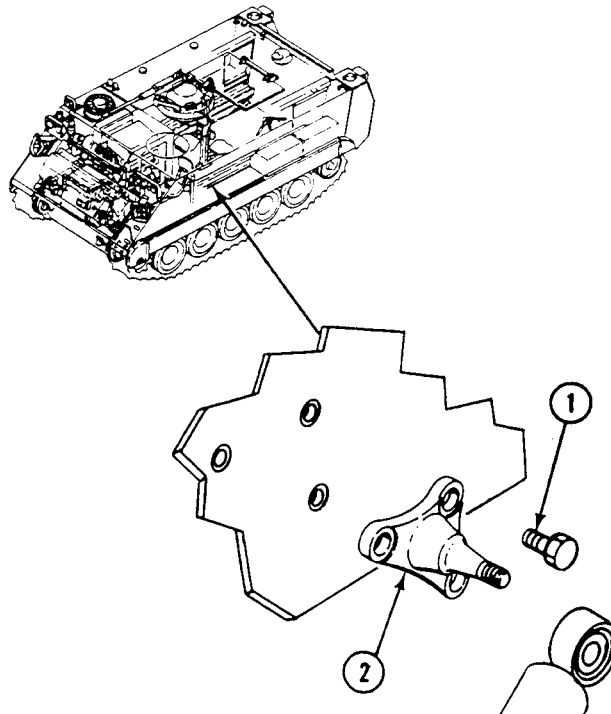

INSTALLATION

1. Install mount (2) on hull.
2. Install three screws (1). Tighten screws to 130-140 lb-ft (176-190 N.m) torque.

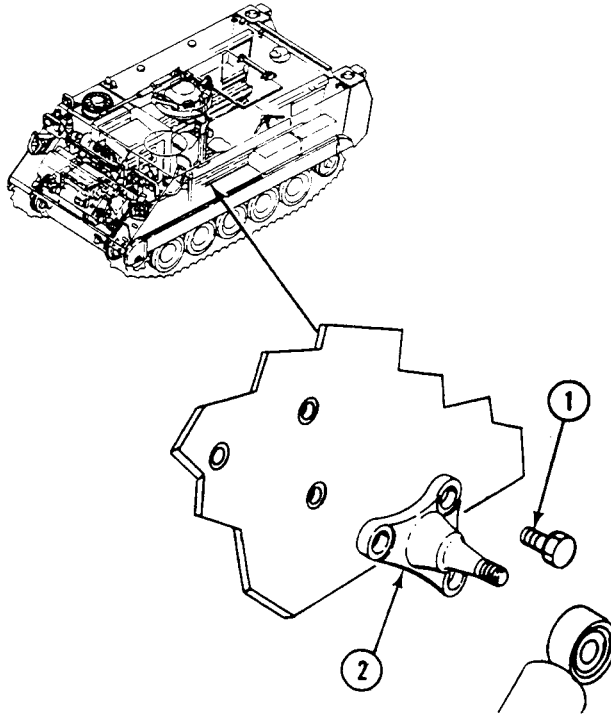
**FOLLOW-THROUGH STEPS**

1. Install shock absorber (WP 0435 00).
2. Install road wheel (WP 0426 00).
3. Install track shroud and covers (WP 0438 00).

END OF TASK

REPLACE SHOCK ABSORBER PIN

0437 00

THIS WORK PACKAGE COVERS:

Removal (page 0437 00-1).
 Installation (page 0437 00-2).

INITIAL SETUP:

Maintenance Level

Unit

References

See your -10

Tools and Special Tools

General Mechanic's Tool Kit (WP 0926 00, Item 65)
 Socket Wrench Set (WP 0926 00, Item 73)
 Torque Wrench (WP 0926 00, Item 86)

Equipment Condition

Respective road wheel support arm removed
 (WP 0415 00)

Personnel Required

Unit Mechanic

REMOVAL

1. Remove nut (1) from pin (2).
2. Place road wheel support arm (3) on wood blocks. Drive out pin (2) with a wood block and hammer.

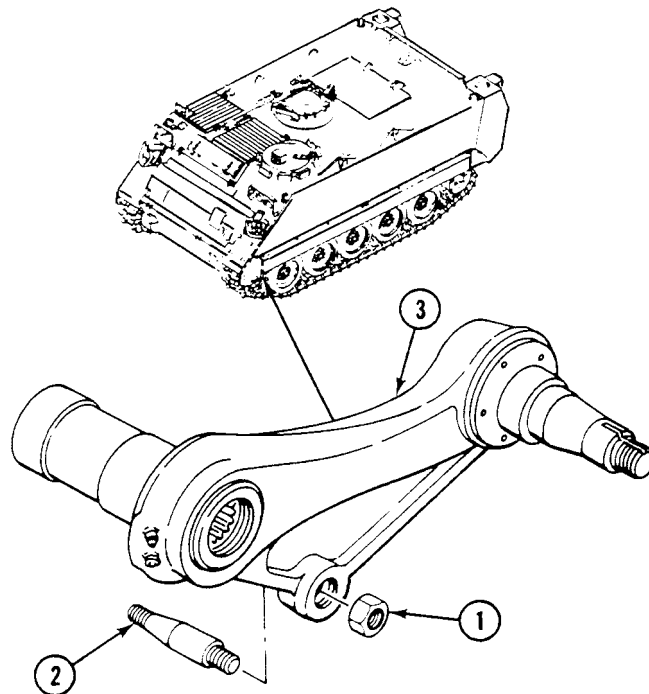

INSTALLATION

1. Install pin (2) in road wheel support arm (3). Secure with nut (1). Tighten nut to 210-230 lb-ft (285-312 N.m).

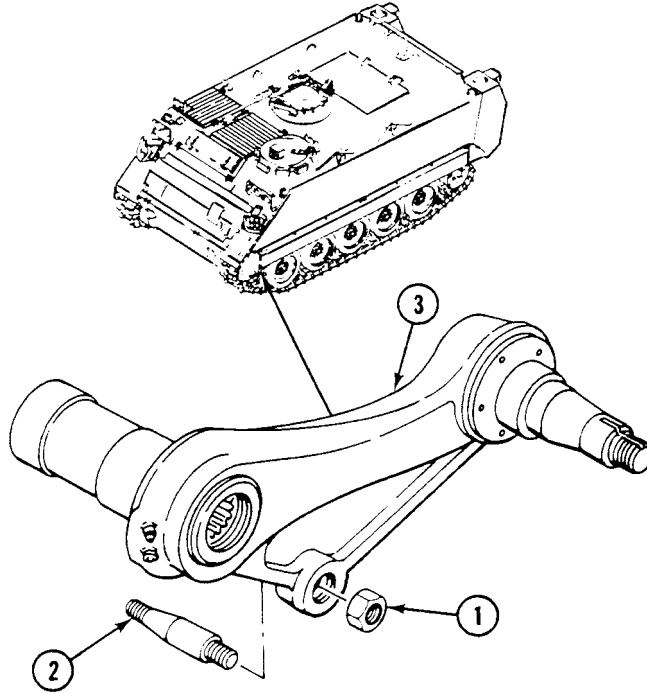
**FOLLOW-THROUGH STEPS**

1. Install road wheel support arm (WP 0415 00).

END OF TASK

CHAPTER 17

UNIT MAINTENANCE INSTRUCTIONS
FOR WHEELS AND TRACKS

WORK PACKAGE INDEX

<u>Title</u>	<u>WP Sequence No.</u>
REPLACE TRACK SHROUD AND COVERS.....	0438 00
REPAIR/REPLACE POWER PLANT REAR ACCESS PANELS	0439 00
REMOVE/INSTALL FAN DRIVE PULLEY ACCESS COVER	0440 00
REPLACE DRIVER'S POWER PLANT ACCESS PANEL	0441 00
REPAIR PAMPHLET BAG MOUNTING.....	0442 00
REPLACE TOWING HOOK AND EYE.....	0443 00
REPLACE LIFTING EYE.....	0444 00
REPLACE REAR TIEDOWN PLATES	0445 00
REPLACE HEADLIGHT GUARD.....	0446 00
REPLACE LEFT FRONT ARMOR PLATE.....	0447 00
REPLACE RIGHT FRONT ARMOR PLATE.....	0448 00
REPLACE HULL FRONT ACCESS COVER.....	0449 00
REPLACE POWER PLANT BOTTOM ACCESS COVER.....	0450 00
REPLACE HULL DRAIN PLUG	0451 00
REPLACE FINAL DRIVE HULL DRAIN PLUGS	0452 00
REPLACE DRIVER'S COMPARTMENT FLOOR PLATES.....	0453 00
REPLACE REAR COMPARTMENT AIR VENTILATOR.....	0454 00
REPLACE SMOKE GRENADE LAUNCHER GUARD, PLATE, AND BASE (M113A3 AND M1059A3 ONLY).....	0455 00
REPLACE WATER BARRIER (M113A3, M577A3, AND M1068A3 ONLY).....	0456 00
REPLACE WATER BARRIER LOOP AND STRAP (M113A3, M577A3, AND M1068A3 ONLY).....	0457 00
REPLACE TRIM VANE	0458 00
REPAIR TRIM VANE (ALL EXCEPT M58).....	0459 00
REPAIR TRIM VANE (M58 ONLY)	0460 00
REPAIR TRIM VANE CONTROL LINKAGE	0461 00
REPLACE TRIM VANE RELEASE.....	0462 00
REPAIR TRIM VANE RELEASE	0463 00
RAISE AND LOWER POWER PLANT GRILLE.....	0464 00
REMOVE/INSTALL POWER PLANT GRILLE	0465 00
REPLACE COMBAT FILLER COVER AND LOCK.....	0466 00
REPLACE POWER PLANT GRILL SUPPORT ARM.....	0467 00

CHAPTER 17

UNIT MAINTENANCE INSTRUCTIONS
FOR WHEELS AND TRACKS

WORK PACKAGE INDEX (Continued)

<u>Title</u>	<u>WP Sequence No.</u>
REPLACE POWER PLANT GRILL SCREEN	0468 00
REPLACE RADIATOR ACCESS DOOR	0469 00
REPLACE POWER PLANT DOOR (M113A3 ONLY).....	0470 00
REPLACE POWER PLANT DOOR (ALL EXCEPT M113A3).....	0471 00
REPAIR POWER PLANT DOOR	0472 00
REPLACE POWER PLANT DOOR COMBAT LOCK	0473 00
REPLACE CARGO HATCH HOLD-OPEN HOOK AND BUMPERS (M113A3 AND M1059A3 ONLY).....	0474 00
REPLACE CARGO HATCH INTERIOR LATCH (M113A3 AND M1059A3 ONLY)	0475 00
DELETED.....	0476 00
DELETED.....	0477 00
REPLACE CARGO HATCH SEALS (M113A3 AND M1059A3 ONLY)	0478 00
REPLACE CARGO HATCH COVER (M113A3 AND M1059A3 ONLY)	0479 00
REPLACE MORTAR HATCH EXTERIOR CATCHES AND BUMPERS (M1064A3 ONLY)	0480 00
REPLACE MORTAR HATCH INTERIOR RELEASE MECHANISMS (M1064A3 ONLY)	0481 00
REPLACE MORTAR HATCH COVERS (M1064A3 ONLY)	0482 00
REPLACE HOPPER HATCH LOCK ASSEMBLY (M58 ONLY).....	0483 00
REPLACE HOPPER HATCH (M58 ONLY).....	0484 00
REPLACE TURBINE ACCESS DOOR (M58 ONLY)	0485 00
REPLACE TURBINE ACCESS DOOR GASKET (M58 ONLY)	0486 00
REPLACE TURBINE ACCESS DOOR HINGES (M58 ONLY).....	0487 00
REPLACE COMMANDER'S CUPOLA CUSHIONING PAD AND HANDLE (M113A3, M1059A3, M58, AND M1064A3 ONLY).....	0488 00
REPLACE COMMANDER'S CUPOLA AZIMUTH LOCK (M113A3, M1059A3, M58 AND M1064A3 ONLY).....	0489 00
REPLACE COMMANDER'S CUPOLA VISION BLOCK LOCKS AND SEALS (M113A3 AND M1059A3, M58 ONLY)	0490 00
REPLACE COMMANDER'S CUPOLA VISION BLOCK LOCKS AND SEALS (M1064A3 ONLY).....	0491 00
REPLACE COMMANDER'S CUPOLA BRAKE ASSEMBLY (M113A3, M1059A3, M58, AND M1064A3 ONLY)	0492 00
REPLACE COMMANDER'S CUPOLA COVER (M113A3, M1059A3, M58, AND M1064A3 ONLY)	0493 00
REPLACE COMMANDER'S CUPOLA HOLD-OPEN HOOK AND BUMPER	

CHAPTER 17

UNIT MAINTENANCE INSTRUCTIONS
FOR WHEELS AND TRACKS

WORK PACKAGE INDEX

<u>Title</u>	<u>WP Sequence No.</u>
(M113A3, M1059A3, M58, AND M1064A3 ONLY)	0494 00
REPLACE COMMANDER'S CUPOLA SAFETY PIN STOWAGE BLOCK (M113A3, M1059A3, M58, AND M1064A3 ONLY)	0495 00
REPLACE COMMANDER'S CUPOLA INTERIOR LATCH (M113A3, M1059A3, M58, AND M1064A3 ONLY)	0496 00
REPLACE COMMANDER'S CUPOLA MACHINE GUN MOUNT (M113A3, M1059A3, M58, AND M1064A3 ONLY)	0497 00
REPAIR COMMANDER'S CUPOLA MACHINE GUN MOUNT (M113A3, M1059A3, M58, AND M1064A3 ONLY)	0498 00
REPLACE COMMANDER'S CUPOLA MACHINE GUN MOUNT STOPS (M1059A3 ONLY)	0499 00
REPLACE COMMANDER'S HATCH CUSHIONING PAD AND HANDLE (M577A3 AND M1068A3 ON0500 00	
REPLACE COMMANDER'S HATCH HOOK AND BUMPER (M577A3 AND M1068A3 ONLY)	0501 00
REPLACE COMMANDER'S HATCH INTERIOR LATCH (M577A3 AND M1068A3 ONLY)	0502 00
REPLACE COMMANDER'S HATCH COVER (M577A3 AND M1068A3 ONLY)	0503 00
REPLACE RIGHT SIDE SPALL LINERS (M113A3 ONLY)	0504 00
REPLACE LEFT SIDE SPALL LINERS (M113A3 ONLY)	0505 00
REPAIR SPALL LINER QUICK RELEASE PINS AND PLATES (M113A3 ONLY)	0506 00
REPLACE FORWARD SPALL LINER AND BRACKET (M113A3 ONLY)	0507 00
REPLACE FORWARD UPPER RIGHT AND LEFT SIDE SPALL LINERS (M113A3 ONLY)	0508 00
REPLACE SPALL LINER ON CARGO HATCH COVER (M113A3 ONLY)	0509 00
REPLACE REAR UPPER HULL SPALL LINER (M113A3 ONLY)	0510 00
REPLACE SPALL LINER ON RAMP DOOR (M113A3 ONLY)	0511 00
REPLACE SPALL LINER ON RAMP (M113A3 ONLY)	0512 00
RAISE/LOWER INOPERABLE/UNSAFE RAMP	0513 00
REPLACE RAMP SEAL	0514 00
REPLACE RAMP DRAIN PLUGS	0515 00
REPLACE RAMP BRACKET (M113A3, M577A3, AND M1068A3 ONLY)	0516 00
REPLACE RAMP DOOR STOP BRACKET	0517 00
REPLACE RAMP DOOR HOOK AND SPRING	0518 00

CHAPTER 17

UNIT MAINTENANCE INSTRUCTIONS
FOR WHEELS AND TRACKS

WORK PACKAGE INDEX (Continued)

<u>Title</u>	<u>WP Sequence No.</u>
REPLACE RAMP DOOR HANDLES AND SHAFT.....	0519 00
REPLACE RAMP DOOR SEAL	0520 00
ADJUST RAMP LOCK (M113A3 AND M1059A3 ONLY).....	0521 00
ADJUST RAMP LOCK (M577A3 AND M1068A3 ONLY).....	0522 00
ADJUST RAMP LOCK (M1064A3 ONLY).....	0523 00
REPLACE RAMP LOCK HANDLE AND ARMS (ALL EXCEPT M577A3 AND M1068A3)	0524 00
REPLACE RAMP LOCK LEVER AND CABLE (M577A3 AND M1068A3 ONLY)	0525 00
REPLACE RAMP LINKAGE (M113A3 AND M1059A3 ONLY).....	0526 00
REPLACE RAMP LINKAGE (M577A3 AND M1068A3 ONLY).....	0527 00
REPLACE RAMP LINKAGE (M1064A3 ONLY).....	0528 00
REPAIR HULL BY WELDING.....	0529 00
REPLACE DRIVER'S HATCH CUSHIONING PAD	0530 00
REPLACE DRIVER'S HATCH COVER AND EXTERIOR LOCK	0531 00
REPLACE DRIVER'S HATCH HOLD-OPEN HOOK AND BUMPER (M113A3, M1059A3, M1064A3, AND M58 ONLY).....	0532 00
REPLACE DRIVER'S HATCH HOLD-OPEN HOOK AND BUMPER (M577A3 AND M1068A3 ONLY)	0533 00
REPLACE DRIVER'S HATCH INTERIOR LOCK AND LATCH.....	0534 00
REPLACE DRIVER'S HATCH VISION BLOCK LOCKS AND SEALS	0535 00
REPLACE DRIVER'S HATCH AN/VVS-2 DRIVER'S NIGHT VISION GUARD (ALL EXCEPT M58)	0536 00
REPLACE DRIVER'S HATCH NIGHT VISION GUARD (M58 ONLY).....	0536 01
REPLACE AN/VVS-2 DRIVER'S NIGHT VISION MOUNT (ALL EXCEPT M58).....	0537 00
REPLACE DRIVER'S HATCH NIGHT VISION MOUNT (M58 ONLY).....	0537 01
DELETED.....	0538 00
REPLACE FLOOR PLATES (M113A3 AND M577A3 ONLY)	0539 00
DELETED.....	0540 00
DELETED.....	0541 00
REPLACE FLOOR PLATES (M1059A3 ONLY)	0542 00
REPLACE FLOOR PLATES (M1064A3 ONLY)	0543 00
REPLACE FLOOR PLATES (M1068A3 ONLY)	0544 00

CHAPTER 17

UNIT MAINTENANCE INSTRUCTIONS
FOR WHEELS AND TRACKS

WORK PACKAGE INDEX

<u>Title</u>	<u>WP Sequence No.</u>
REPLACE FLOOR PLATES (M58 ONLY)	0545 00
REPLACE PERSONNEL SEATS, CUSHIONS, AND BELTS (M113A3 ONLY)	0546 00
REPLACE PERSONNEL SEAT, CUSHION, AND BELTS (M577A3 ONLY)	0547 00
DELETED	0548 00 ■
REPLACE PERSONNEL SEATS, BACKRESTS, CUSHIONS, AND BELTS (M1059A3 ONLY) ..	0549 00
REPLACE PERSONNEL SEATS, BACKRESTS, CUSHIONS, AND BELTS (M1064A3 ONLY) ..	0550 00
REPLACE DRIVER'S SEAT ASSEMBLY	0551 00
REPAIR DRIVER'S SEAT	0552 00
REPLACE DRIVER'S SEAT BACK ASSEMBLY	0553 00
REPAIR DRIVER'S SEAT BACK ASSEMBLY	0554 00
REPLACE DRIVER'S SEAT IMPACT ABSORBER	0555 00
REPLACE DRIVER'S SEAT POST ASSEMBLY	0556 00
REPAIR DRIVER'S SEAT POST ASSEMBLY	0557 00
REPLACE DRIVER'S FOOTREST	0558 00
REPLACE/REPAIR COMMANDER'S PLATFORM (M113A3, M1059A3, M1064A3, AND M58 ONLY)	0559 00
REPLACE COMMANDER'S SEAT AND POST (M113A3, M1059A3, AND M58 ONLY)	0560 00
REPLACE COMMANDER'S SEAT AND POST (M1064A3 ONLY)	0561 00
REPAIR COMMANDER'S SEAT (M113A3, M1059A3, M1064A3, AND M58 ONLY)	0562 00
REPLACE COMMANDER'S JUMP SEAT (M113A3 ONLY)	0563 00
REPLACE/REPAIR COMMANDER'S PLATFORM AND POST (M577A3 AND M1068A3 ONLY)	0564 00
DELETE	0565 00 ■
REPLACE/REPAIR COMMANDER'S SEAT (M1068A3 ONLY)	0566 00
REPLACE/REPAIR OPERATOR'S SEAT (M1059A3 ONLY)	0567 00
REPLACE/REPAIR RADIO OPERATOR'S SEAT (M1068A3 AND M58 ONLY)	0568 00 ■
REPLACE WEBBING STRAPS	0569 00
REPLACE CUSHIONING PADS	0570 00
REPLACE TOOL BOX LOOPS	0571 00
REPLACE AN/VVS-2 DRIVER'S NIGHT VISION STOWAGE MOUNT (ALL EXCEPT M58)	0572 00

CHAPTER 17

UNIT MAINTENANCE INSTRUCTIONS
FOR WHEELS AND TRACKS

WORK PACKAGE INDEX (Continued)

<u>Title</u>	<u>WP Sequence No.</u>
REPLACE RIFLE BRACKETS	0573 00
REPLACE OIL CAN BRACKET	0574 00
REPLACE ANTENNA GUARDS	0575 00
REPLACE T150 TRACK SHOE STOWAGE BRACKET.....	0575 01
REPLACE ANTENNA COVERS	0576 00
REPLACE LEFT BULKHEAD RADIO STOWAGE RACKS (M577A3 AND M1068A3 ONLY).....	0577 00
REPLACE LEFT TABLE (M577A3 ONLY).....	0578 00
REPLACE RIGHT FRONT RADIO STOWAGE RACK (M577A3 ONLY)	0579 00
REPLACE MAP BOARD (M577A3 ONLY)	0580 00
REPLACE RIGHT FORWARD TABLE (M577A3 ONLY).....	0581 00
REPLACE RIGHT REARWARD TABLE (M577A3 ONLY).....	0582 00
DELETED.....	0583 00
DELETED.....	0584 00
DELETED.....	0585 00
REPLACE/REPAIR RAMP VISION PORT AND SHIELD (M58 ONLY).....	0586 00
DELETED.....	0587 00
DELETED.....	0588 00
DELETED.....	0589 00
DELETED.....	0590 00
DELETED.....	0591 00
DELETED.....	0592 00
DELETED.....	0593 00
DELETED.....	0594 00
DELETED.....	0595 00
DELETED.....	0596 00
DELETED.....	0597 00
DELETED.....	0598 00
DELETED.....	0599 00
DELETED.....	0600 00
DELETED.....	0601 00

CHAPTER 17

UNIT MAINTENANCE INSTRUCTIONS
FOR WHEELS AND TRACKS

WORK PACKAGE INDEX

<u>Title</u>	<u>WP Sequence No.</u>
REPLACE ANTENNA SUPPORT (M58 ONLY)	0602 00
REPLACE CABLE REEL HOLDER ASSEMBLY (M1064A3 ONLY).....	0603 00
REPAIR CABLE REEL HOLDER ASSEMBLY (M1064A3 ONLY)	0604 00
DELETED	0605 00
REPLACE HORIZONTAL AMMUNITION RACK (M1064A3 ONLY)	0606 00
REPAIR HORIZONTAL AMMUNITION RACK (M1064A3 ONLY)	0607 00
REPLACE VERTICAL AMMUNITION RACK (M1064A3 ONLY).....	0608 00
REPLACE RADIO STOWAGE RACK (M1064A3 ONLY).....	0609 00
REPLACE GRENADE STOWAGE BOX (M1064A3 ONLY).....	0610 00
REPLACE PERISCOPE STOWAGE BOX (M1064A3 ONLY).....	0611 00
REPLACE RIFLE RACK (M1064A3 ONLY).....	0612 00
REPLACE SIGHT EXTENSION ARM STOWAGE BRACKETS (M1064A3 ONLY).....	0613 00
REPLACE WINDSHIELD STOWAGE BRACKET (M1064A3 ONLY).....	0614 00
REPLACE MORTAR BASE STOWAGE BRACKET (M1064A3 ONLY).....	0615 00
REPLACE LEFT SIDE RACK BASE (M1068A3 ONLY)	0616 00
REPLACE PERSONNEL HEATER CONTROL BOX AND INTERCOM BOX BRACKET (M1068A3 ONLY).....	0617 00
REPLACE/REPAIR MAP BOARD (M1068A3 ONLY)	0618 00
REPLACE MAP STORAGE BOX (M1068A3 ONLY).....	0619 00
REPAIR MAP STORAGE BOX (M1068A3 ONLY)	0620 00
REPLACE RIGHT SIDE SHELF ASSEMBLY (M1068A3 ONLY).....	0621 00
REPLACE RIGHT SIDE RACK BASE (M1068A3 ONLY).....	0622 00
REPLACE RIGHT SIDE BASE EXTENSION (M1068A3 ONLY)	0623 00
REPLACE RIGHT SIDE BASE EXTENSION SUPPORTS (M1068A3 ONLY).....	0624 00
REPLACE/REPAIR ANTENNA MAST BRACKET ASSEMBLY, TAILLIGHT WIRING HARNESS, AND BRACKET (M1068A3 ONLY).....	0625 00
REPLACE REAR EXTERNAL STOWAGE FRAME (M1068A3 ONLY)	0626 00
REPLACE STOWAGE BRACKETS FOR W1, W2, AND NATO SLAVE CABLES (M1068A3 AND M577A3)	0626 01

REPLACE TRACK SHROUD AND COVERS

0438 00

THIS WORK PACKAGE COVERS:

Removal (page 0438 00-1).
 Installation (page 0438 00-2).

INITIAL SETUP:

Maintenance Level

Unit

References

See your -10

Tools and Special Tools

General Mechanic's Tool Kit (WP 0926 00, Item 65)

Equipment Condition

Engine stopped (see your -10).

Personnel Required

Unit Mechanic

Carrier blocked (see your -10).

REMOVAL

1. Remove five screws (1) and washers (2) from rear shroud cover (3). Remove cover and clamp (4).
2. Remove six screws (5) and washers (6) from front shroud cover (7). Remove cover and clamp (8).
3. Remove eight screws (9), washers (10), and two clamps (11).
4. Remove shroud (12) from carrier.

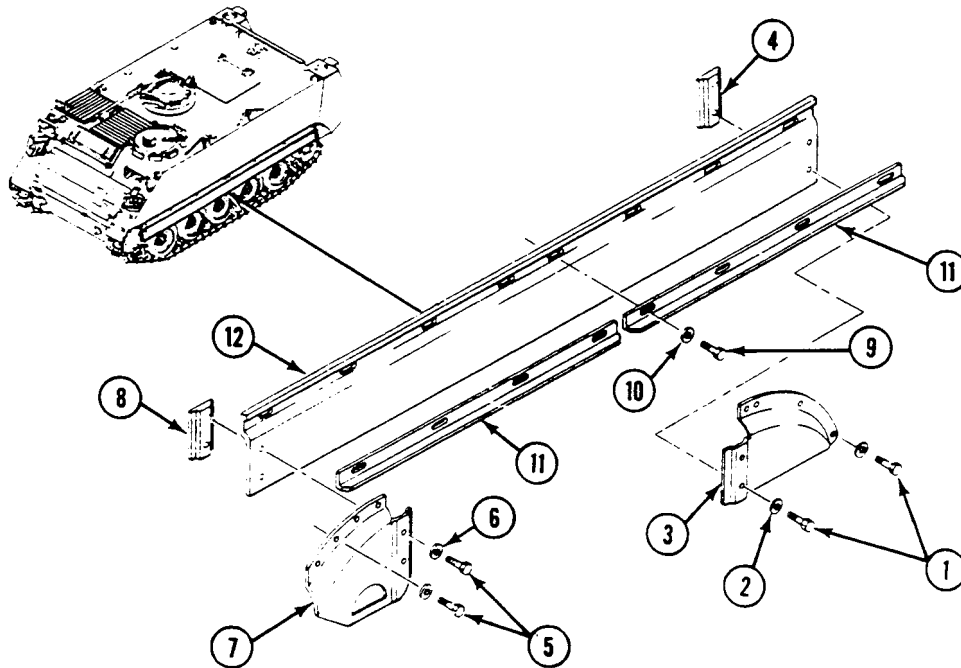

INSTALLATION

1. Place shroud (12) on carrier. Secure with two clamps (11), eight washers (10), and screws (9).
2. Install clamp (8) behind shroud, and cover (7) in front of shroud. Secure to hull with six washers (6) and screws (5).
3. Install clamp (4) behind shroud, and cover (3) in front of shroud. Secure to hull with five washers (2) and screws (1).
4. Tighten all screws.

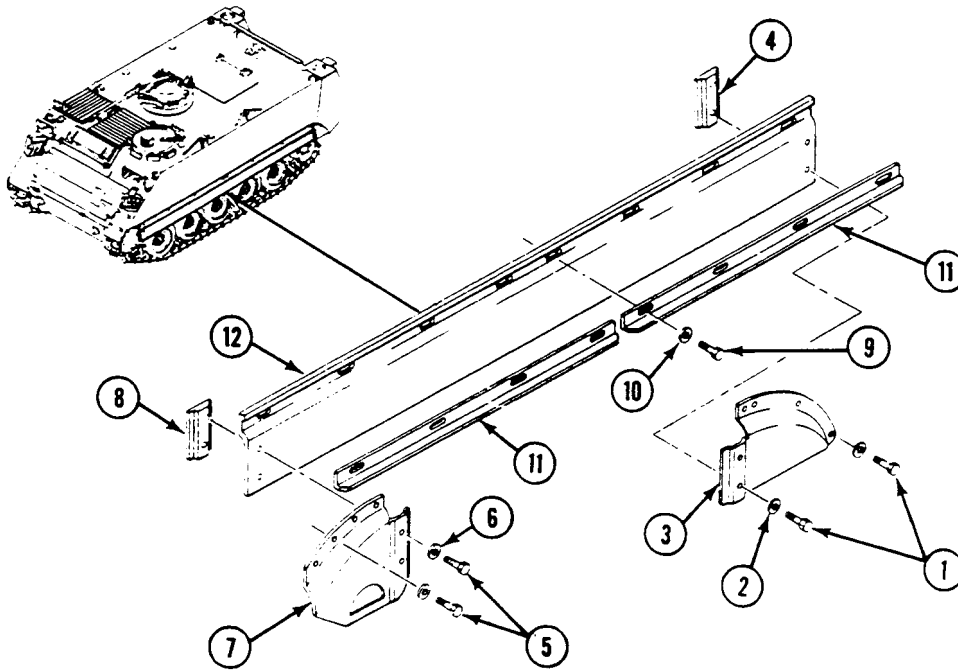
**END OF TASK**

REPAIR/REPLACE POWER PLANT REAR ACCESS PANELS

0439 00

THIS WORK PACKAGE COVERS:

- Removal (page 0439 00-1).
 - Installation (page 0439 00-2).
-

INITIAL SETUP:

Maintenance Level

Unit

Personnel Required

Unit Mechanic

Tools and Special Tools

General Mechanic's Tool Kit (WP 0926 00, Item 65)

References

See your -10

Materials/Parts

- Cotter pin (7)
- Locknut (6)

Equipment Condition

- Engine stopped (see your -10)
 - Carrier blocked (see your -10)
-

REMOVAL

1. Unscrew seven T-bolts (1). Remove upper and lower panels (2) and (3).

NOTE

Do Step 2 for M901A3, M1068A3, and M1064A3 only. Replace strap loops only if damaged. M901A3 and M1068A3 have two strap loops and M1064A3 has six strap loops.

2. Remove two screws (4), washers (5), locknuts (6), and strap loops (7) from upper panel (2). Discard locknuts.

NOTE

Do Step 3 for M901A3, M1068A3, and M1064A3 only. M901A3 and M1068A3 have one snap-fastener stud and M1064A3 has two snap-fastener studs.

3. Remove locknut (6), two washers (5), and snap-fastener stud (8) from upper panel (2). Discard locknut.
4. Bend back seal supports on panel to remove seals (9) and (10).
5. Remove seven cotter pins (11), T-bolts (1), washers (12), and clamps (13) from hull. Discard cotter pins.
6. Remove seven screws (15) and spacers (16) from hull.
7. Remove two locknuts (17), screws (18), and cover (19) from hull. Discard locknuts.

NOTE

Do Step 6 for M901A3, M1068A3, and M1064A3 only. Replace strap loops only if damaged. M901A3 and M1068A3 have two strap loops and M1064A3 has six strap loops.

6. If removed, install two screws (17), strap loops (18), two washers (14), and new locknuts (15) on upper panel (16).
7. If removed, install new seals (19) and (20) on panels (16) and (21). Bend seal supports to secure seals to panels.

WARNING

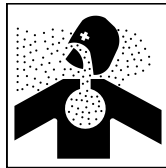

Carbon monoxide gas is deadly poison. Play it safe! Make sure power plant access panels are closed tight before you start engine.

8. Install panels (16) and (21) on hull. Tighten seven clamps (9) and T-bolts (11).
9. Make sure panel seals hull opening to prevent carbon monoxide leaks.

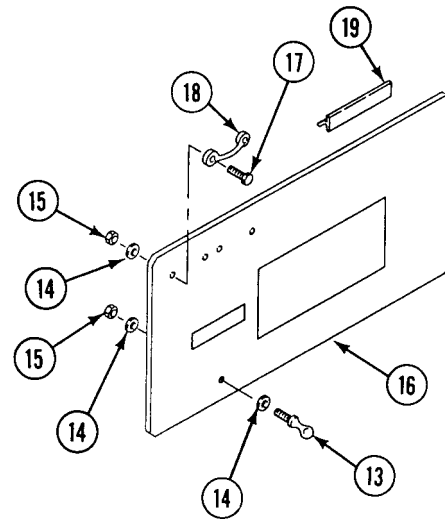
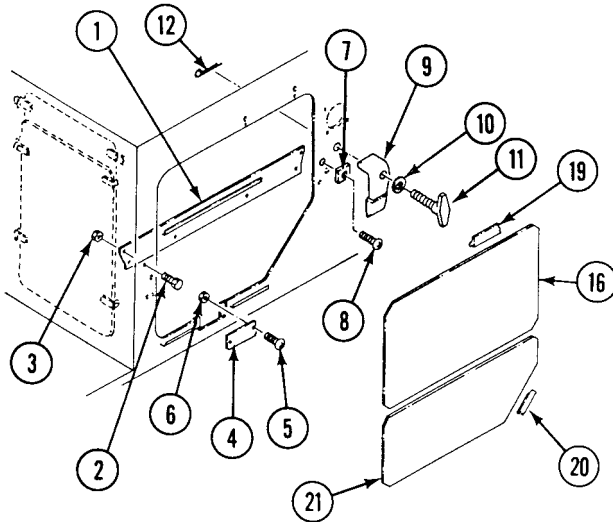

FOLLOW-THROUGH STEPS

1. Start engine (see your -10).
2. Stop engine (see your -10).

END OF TASK

REMOVE/INSTALL FAN DRIVE PULLEY ACCESS COVER

0440 00

THIS WORK PACKAGE COVERS:

Removal (page 0440 00-1).
 Installation (page 0440 00-2).

INITIAL SETUP:

Maintenance Level

Unit

References

see your -10

Tools and Special Tools

General Mechanic's Tool Kit (WP 0926 00, Item 65)

Equipment Condition

Engine stopped (see your -10)

Carrier blocked (see your -10)

Materials/Parts

Lockwasher (4)

Power plant upper rear access panel removed (see your -10)

Personnel Required

Unit Mechanic

REMOVAL

1. Remove four screws (1), lockwashers (2), washers (3), and fan pulley access cover (4) from power plant compartment rear bulkhead. Discard lockwashers.

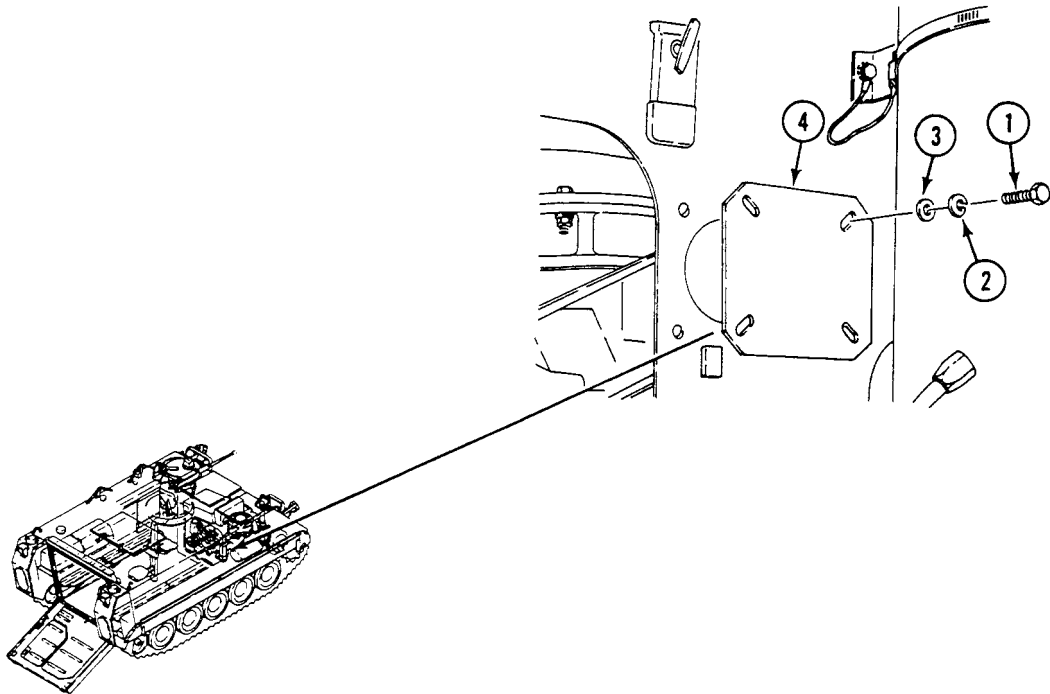

INSTALLATION

1. Install cover (4) on power plant compartment rear bulkhead. Secure with four washers (3), new lockwashers (2), and screws (1).

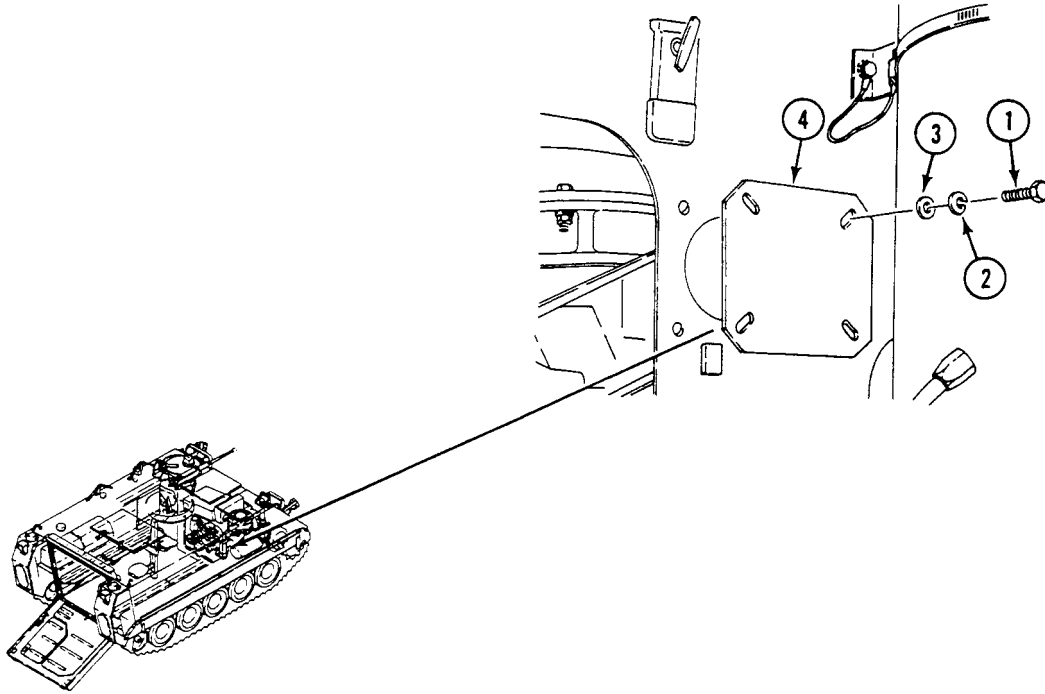
**FOLLOW-THROUGH STEPS**

1. Install power plant upper rear access panel (see your -10).

END OF TASK

REPLACE DRIVER'S POWER PLANT ACCESS PANEL

0441 00

THIS WORK PACKAGE COVERS:

Removal (page 0441 00-1).
 Installation (page 0441 00-3).

INITIAL SETUP:

Maintenance Level

Unit

References

See your -10

Tools and Special Tools

General Mechanic's Tool Kit (WP 0926 00, Item 65)

Materials/Parts

Cotter pin (6)

Equipment Condition

Engine stopped (see your -10)

Personnel Required

Unit Mechanic

Carrier blocked (see your -10)

REMOVAL

NOTE

If decals and dataplates on panel need to be replaced, see (WP 0654 00).

1. Unscrew four T-bolts (1). Remove driver's access panel (2) from hull.

NOTE**Remove seal only if damaged.**

2. Bend back seal support to remove seal (3).
3. Remove four cotter pins (4), T-bolts (1), washers (5), and clamps (6) from hull. Discard cotter pins.
4. Remove four screws (7) and spacers (8) from hull.

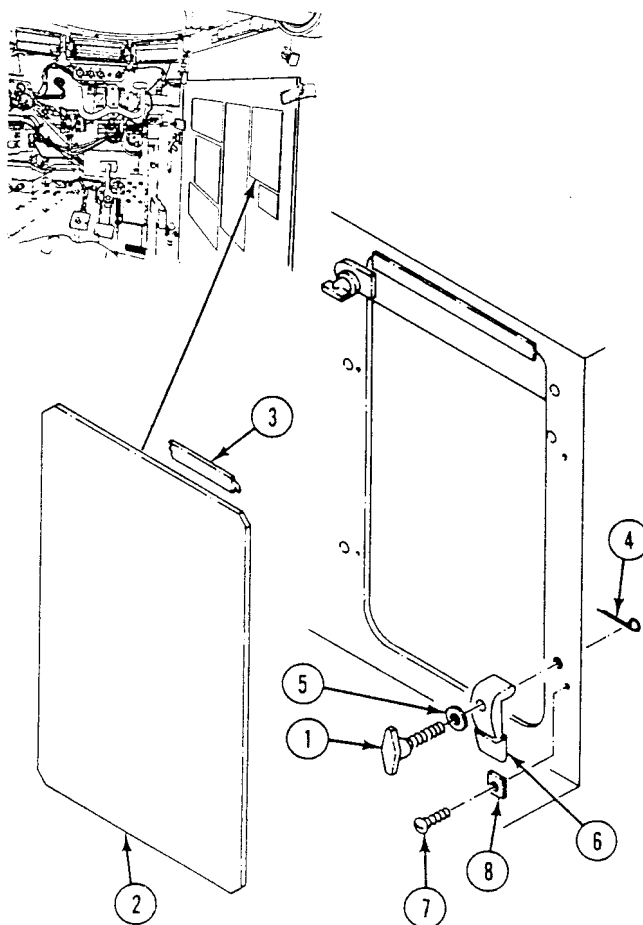

INSTALLATION

1. Install four spacers (1) on hull. Secure with four screws (2).
2. Install four clamps (3), washers (4), T-bolts (5), and new cotter pins (6).
3. If new seal (7) is needed, install on panel (8). Bend support to secure seal to panel.

WARNING

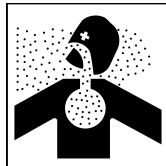

Carbon monoxide gas is deadly poison. Play it safe! Make sure power plant access panels are closed tight before you start engine.

4. Install driver's access panel (8) in hull. Secure by tightening four T-bolts (5) and clamps (3).
5. Make sure panel seals hull opening to prevent carbon monoxide leaks.

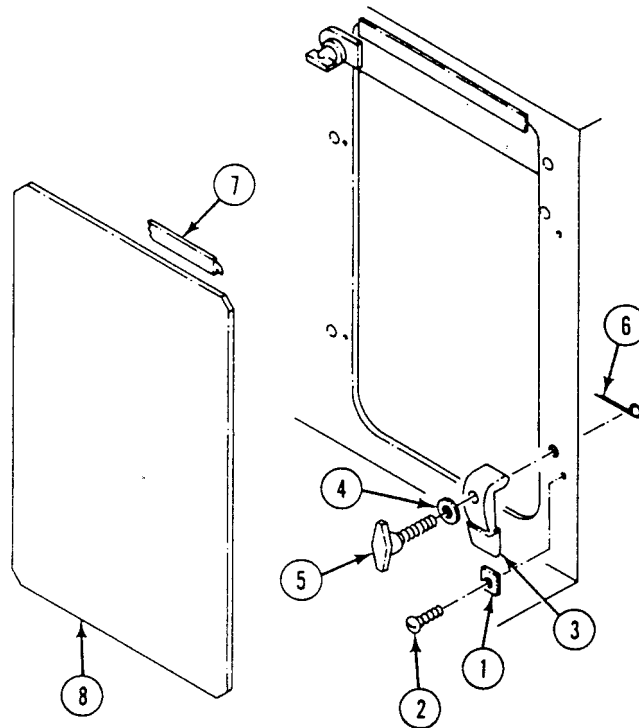

FOLLOW-THROUGH STEPS

1. Start engine (see your -10).
2. Check for exhaust leaks around panel seals.
3. Stop engine (see your -10).

END OF TASK

REPAIR PAMPHLET BAG MOUNTING

0442 00

THIS WORK PACKAGE COVERS:

Removal (page 0442 00-1).
 Installation (page 0442 00-2).

INITIAL SETUP:

Maintenance Level

Unit

References

See your -10

Tools and Special Tools

General Mechanic's Tool Kit (WP 0926 00, Item 65)

Equipment Condition

Engine stopped (see your -10)

Carrier blocked (see your -10)

Materials/Parts

Locknut (3)

Driver's power plant access panel removed (see your -10)

Personnel Required

Unit Mechanic

REMOVAL

1. Remove two screws (1), locknuts (2), washers (3), and loop (4) from panel. Discard locknuts.
2. Remove locknut (5), washer (6), and stud (7) from panel. Discard locknut.

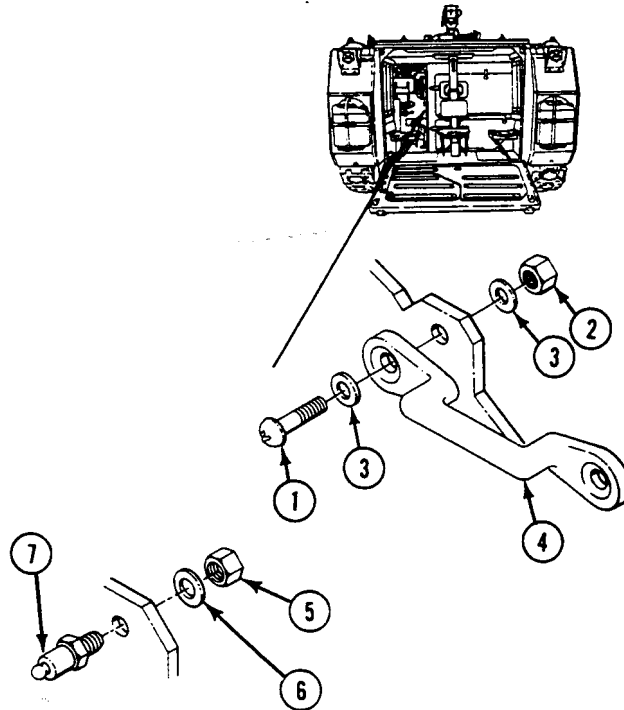

INSTALLATION

1. Install loop (4) on panel. Secure with two screws (1), washers (3), and new locknuts (2).
2. Install stud (7) on panel. Secure with new locknut (5) and washer (6).

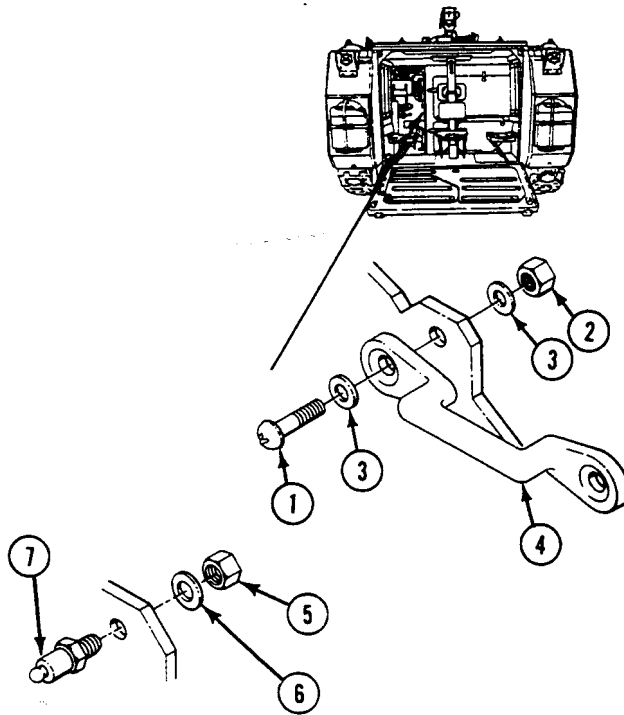
**FOLLOW-THROUGH STEPS**

1. Install driver's power plant access panel (see your -10).

END OF TASK

REPLACE TOWING HOOK AND EYE

0443 00

THIS WORK PACKAGE COVERS:

- Removal (page 0443 00-1).
- Installation (page 0443 00-2).

INITIAL SETUP:

Maintenance Level

Unit

References

See your -10

Tools and Special Tools

- General Mechanic's Tool Kit (WP 0926 00, Item 65)
- Torque Wrench (WP 0926 00, Item 85)

Equipment Condition

- Engine stopped (see your -10)
- Carrier blocked (see your -10)

Personnel Required

Unit Mechanic

NOTE

Rear eyes on ramp are old style, they are removed and installed the same way. The new style eye is follow tie down of the vehicle without shackles. Only the front eyes require the new style eyes.

REMOVAL

1. Remove clip (1), pin (2), and hook (3) from eye (4).
2. Remove six screws (5) and eye (4) from carrier hull.

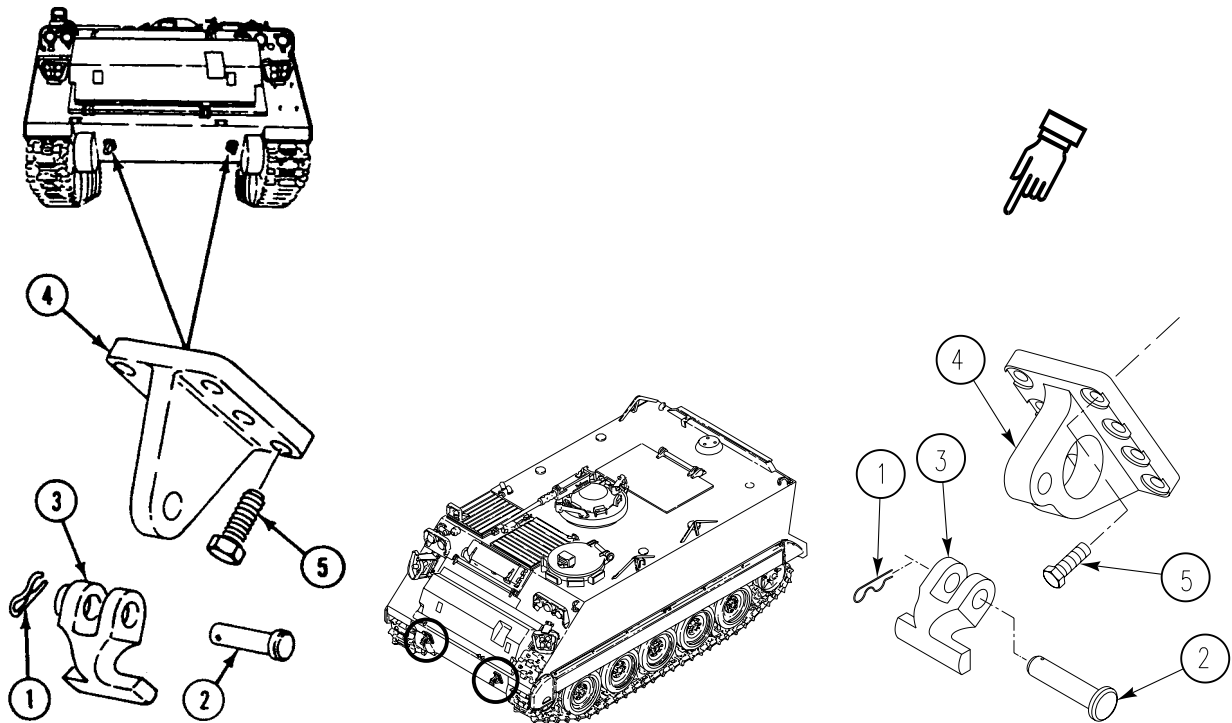

INSTALLATION

NOTE

Front towing eye is marked TOP. Use only top six holes for securing the towing eye to the hull. The other holes are reserved for future use.

1. Align eye (1) on carrier hull and secure with six screws (2). Tighten screws to 151-166 lb-ft (205-225 N•m) torque. Use torque wrench.
2. Install hook (3) on eye (1). Secure with pin (4) and clip (5).

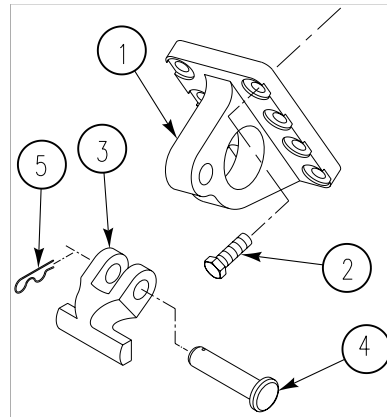
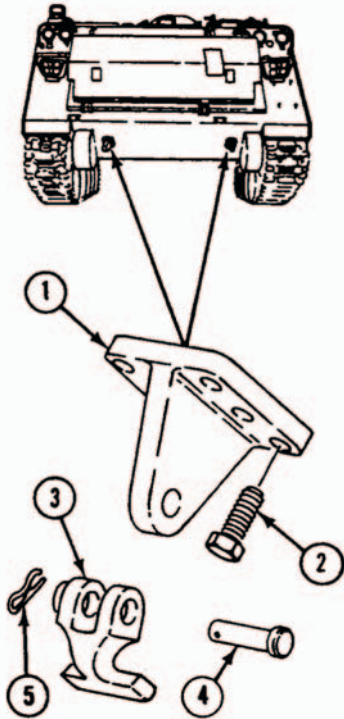

END OF TASK

REPLACE LIFTING EYE

0444 00

THIS WORK PACKAGE COVERS:

Removal (page 0444 00-1).
 Installation (page 0444 00-1).

INITIAL SETUP:

Maintenance Level

Unit

Personnel Required

Unit Mechanic

Tools and Special Tools

General Mechanic's Tool Kit (WP 0926 00, Item 65)
 Socket Adapter (WP 0926 00, Item 1)
 Torque Wrench (WP 0926 00, Item 86)

References

See your -10

Equipment Condition

Engine stopped (see your -10)
 Carrier blocked (see your -10)

REMOVAL

NOTE

Right front lifting eye has one screw (2) 2-3/4 inches (7 cm) long and three screws 2-1/2 inches (6 cm) long. All other lifting eyes use four screws 2-1/2 inches (6 cm) long.

1. Remove four screws (1) or screws (1)(2) that secure lifting eye (3) to hull.

INSTALLATION

1. Install lifting eye (3) on hull. Secure with four screws (1) or screws (1)(2).
2. TIGHTEN SCREWS (1)(2) TO 175-200 LB-FT (237-271 N·m) TORQUE.

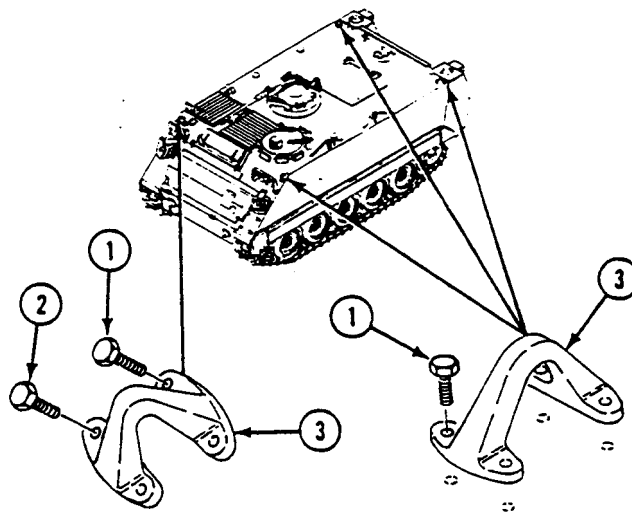

END OF TASK

REPLACE REAR TIEDOWN PLATES

0445 00

THIS WORK PACKAGE COVERS:

Removal (page 0445 00-1).
 Installation (page 0445 00-2).

INITIAL SETUP:

Maintenance Level

Unit

Personnel Required

Unit Mechanic

Tools and Special Tools

General Mechanic's Tool Kit (WP 0926 00, Item 65)
 Socket Wrench Set (WP 0926 00, Item 73)
 Torque Wrench (WP 0926 00, Item 86)

References

See your -10

Materials/Parts

Sealing compound primer (WP 0928 00, Item 57)
 Sealing compound (WP 0928 00, Item 48)

Equipment Condition

Engine stopped (see your -10)
 Carrier blocked (see your -10)

REMOVAL

1. Remove 12 screws (1) and two plates (2) from bottom of carrier.

INSTALLATION

1. Install two plates to bottom of carrier.
 - a. Apply a light coat of sealing compound primer and sealing compound to the threads of the 12 screws (1).
 - b. Install two plates (2) and coated screws (1) to bottom of carrier.
2. TIGHTEN 12 SCREWS (1) TO 268-295 LB-FT (363-400 N·m) TORQUE.

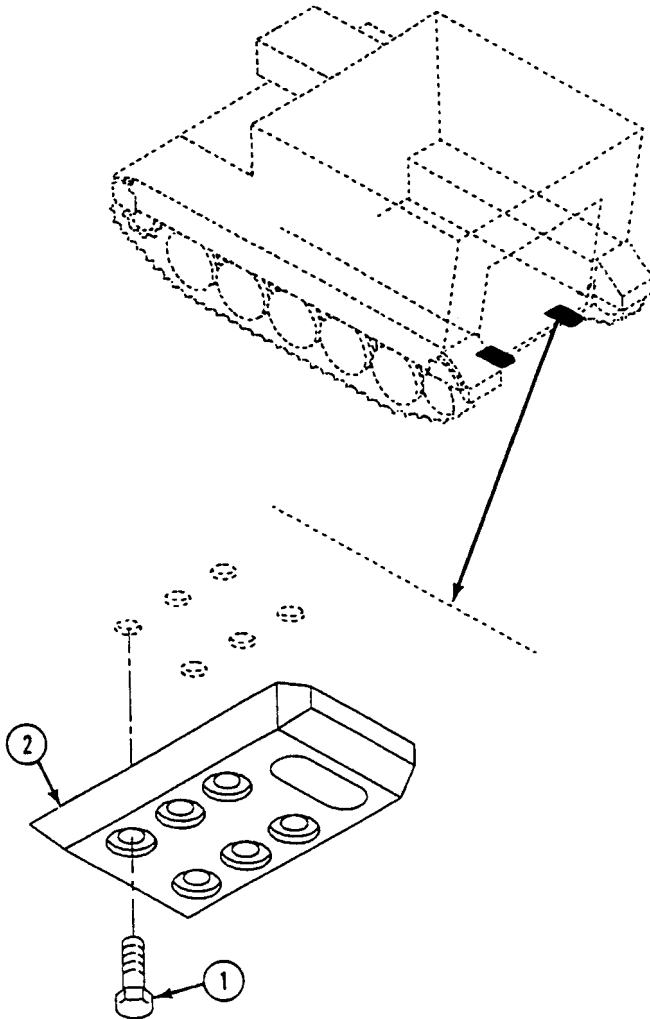

M577A3/M1068A3 SHOWN. Tiedown plates are in same location on other vehicles.

END OF TASK

REPLACE HEADLIGHT GUARD

0446 00

THIS WORK PACKAGE COVERS:

Removal (page 0446 00-1).
 Installation (page 0446 00-2).

INITIAL SETUP:

Maintenance Level

Unit

References

See your -10

Tools and Special Tools

General Mechanic's Tool Kit (WP 0926 00, Item 65)

Equipment Condition

Engine stopped (see your -10)

Materials/Parts

Locknut (8)

Carrier blocked (see your -10)

Personnel Required

Unit Mechanic

REMOVAL

1. Remove four locknuts (1), washers (2), screws (3), and right headlight guard (4) from hull mount. Discard locknuts.
2. Remove four locknuts (1), washers (2), screws (3), and left headlight guard (5) from hull mount. Discard locknuts.

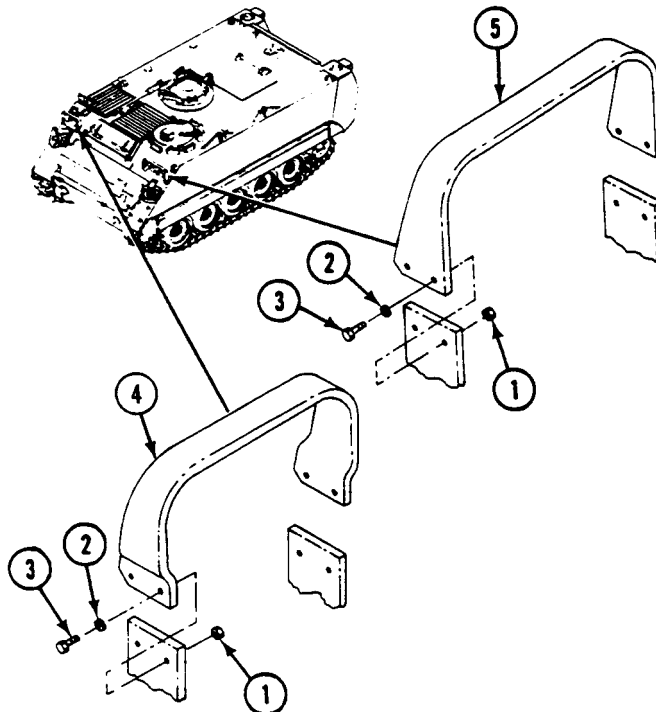

INSTALLATION

1. Install left headlight guard (5), four washers (2), screws (3), and new locknuts (1) on hull mount.
2. Install right headlight guard (4), four washers (2), screws (3), and new locknuts (1) on hull mount.

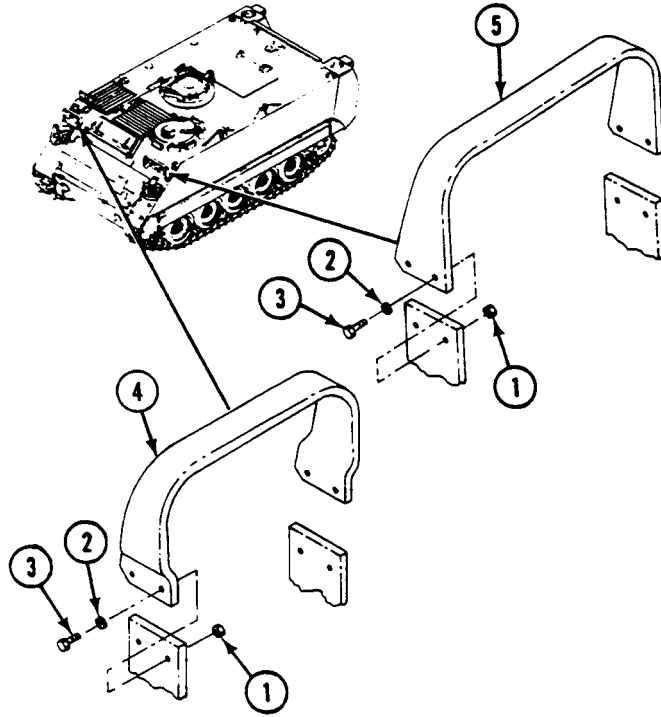
**END OF TASK**

REPLACE LEFT FRONT ARMOR PLATE

0447 00

THIS WORK PACKAGE COVERS:

Removal (page 0447 00-1).
 Installation (page 0447 00-2).

INITIAL SETUP:

Maintenance Level

Unit

References

See your -10

Tools and Special Tools

General Mechanic's Tool Kit (WP 0926 00, Item 65)
 Torque Wrench (WP 0926 00, Item 85)

Equipment Condition

Engine stopped (see your -10)
 Carrier blocked (see your -10)
 Headlight guard removed (WP 0446 00)
 Service and infrared headlight removed (WP 0303 00)
 Blackout marker light removed (WP 0307 00)
 Blackout headlight removed (WP 0305 00)

Personnel Required

Unit Mechanic

REMOVAL

CAUTION

Electrical wiring can be damaged if crushed, torn, or pinched by unsecured armor.

1. Remove three screws (1), washers (2), and left front armor plate (3) from carrier.

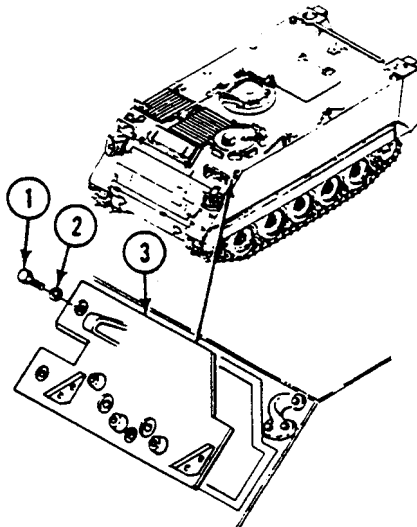

INSTALLATION

1. Install left front armor plate (3) on carrier. Align screw holes. Secure with three washers (2) and screws (1). **TIGHTEN SCREWS TO 100-125 LB-FT (136-170 N·m) TORQUE.**

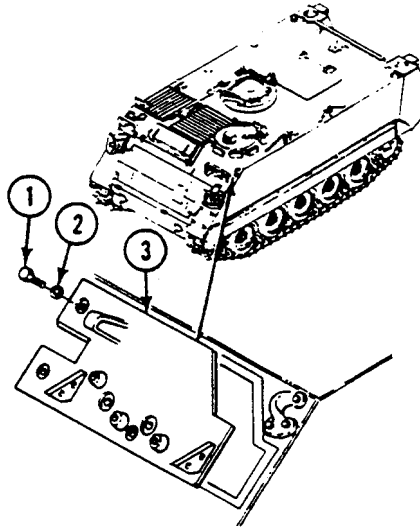
**FOLLOW-THROUGH STEPS**

1. Install blackout headlight (WP 0305 00).
2. Install blackout marker light (WP 0307 00).
3. Install service and infrared headlight (WP 0303 00).
4. Install headlight guard (WP 0446 00).

END OF TASK

REPLACE RIGHT FRONT ARMOR PLATE

0448 00

THIS WORK PACKAGE COVERS:

Removal (page 0448 00-1).
 Installation (page 0448 00-3).

INITIAL SETUP:

Maintenance Level

Unit

References

See your -10

Tools and Special Tools

General Mechanic's Tool Kit (WP 0926 00, Item 65)
 Socket Adapter (WP 0926 00, Item 1)
 Torque Wrench (WP 0926 00, Item 86)

Equipment Condition

Engine stopped (see your -10)
 Carrier blocked (see your -10)
 Trim vane lowered (see your -10)
 Head light guard removed (WP 0446 00)
 Service and infrared lights removed (WP 0303 00)
 Blackout marker light removed (WP 0307 00)
 Horn and ground lead removed (WP 0336 00)

Personnel Required

Unit Mechanic
 Helper (H)

REMOVAL

CAUTION

Electrical wiring harness can be damaged if crushed, torn, or pinched by unsecured armor plate.

1. Remove 11 screws (1), washers (2), and right front armor plate (3) from carrier. Have helper assist.

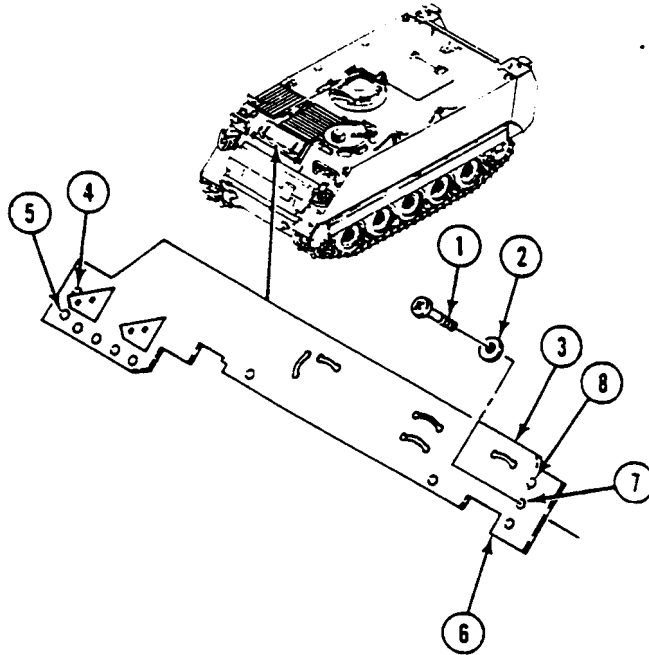

INSTALLATION

1. Install armor plate (3) on hull. Align screw holes. Have helper assist.
2. Secure armor (3) to hull with 11 screws (1) and washers (2). TIGHTEN FIVE SCREWS AT LOCATIONS (4 THROUGH 8) TO 175-200 LB-FT (238-272 N·m) TORQUE.

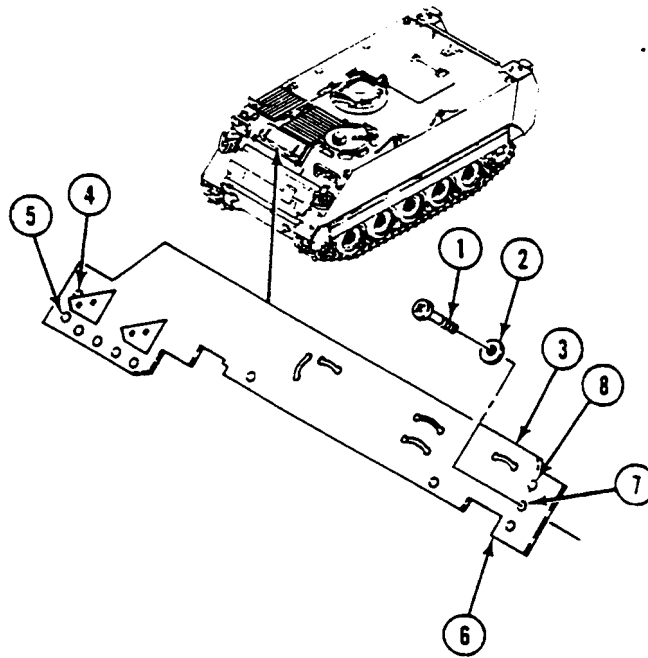
**FOLLOW-THROUGH STEPS**

1. Install horn and ground lead (WP 0336 00).
2. Install blackout marker light (WP 0307 00).
3. Install service and infrared lights (WP 0303 00).
4. Install headlight guard (WP 0446 00).
5. Raise trim vane (see your -10).

END OF TASK

REPLACE HULL FRONT ACCESS COVER

0449 00

THIS WORK PACKAGE COVERS:

Removal (page 0449 00-1).
 Installation (page 0449 00-2).

INITIAL SETUP:

Maintenance Level

Unit

Personnel Required

Unit Mechanic

Tools and Special Tools

General Mechanic's Tool Kit (WP 0926 00, Item 65)
 Torque Wrench (WP 0926 00, Item 85)

References

See your -10

Materials/Parts

Adhesive (WP 0928 00, Item 4)

Equipment Condition

Engine stopped (see your -10)
 Carrier blocked (see your -10)
 Trim vane lowered (see your -10)

REMOVAL

1. Remove four screws (1), washers (2), and cover (3) from hull.
2. If damaged, remove gasket (4) from cover (3).

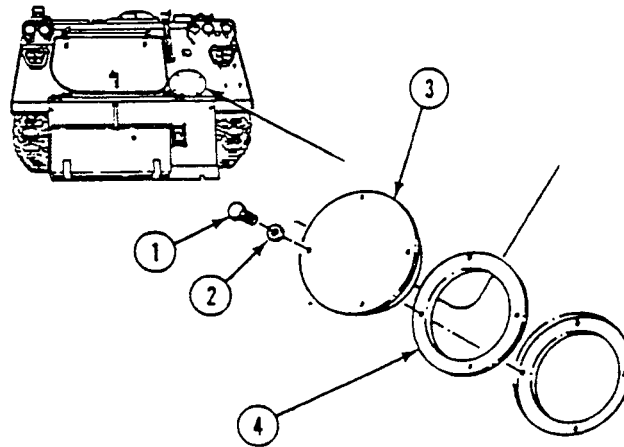

INSTALLATION

1. If gasket is being replaced, apply a thin coat of adhesive to one side of new gasket and allow to dry 20-40 minutes. Apply thin coat of adhesive to cleaned bottom side of cover. Allow to dry 30-120 seconds.
2. Position gasket (4) on cleaned bottom side of cover (3). Align mounting holes in cover and gasket.
3. Secure cover (3) and gasket (4) to hull with four screws (1) and washers (2). TIGHTEN SCREWS TO 40-50 LB-FT (54-68 N·m) TORQUE.

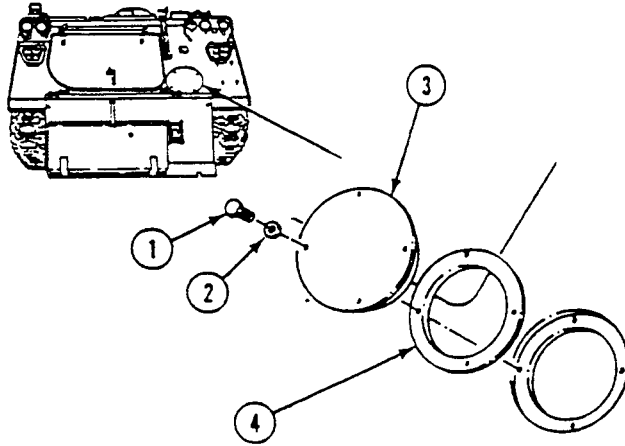
**FOLLOW-THROUGH STEPS**

1. Raise trim vane (see your -10).

END OF TASK

REPLACE POWER PLANT BOTTOM ACCESS COVER

0450 00

THIS WORK PACKAGE COVERS:

- Remove (page 0450 00-1).
- Cleaning (page 0450 00-2).
- Install (page 0450 00-3).

INITIAL SETUP:

Maintenance Level

Unit

Personnel Required

Unit Mechanic

Tools and Special Tools

- General Mechanic's Tool Kit (WP 0926 00, Item 65)
- Torque Wrench (WP 0926 00, Item 85)

References

See your -10

Materials/Parts

- Adhesive (WP 0928 00, Item 4)
- Antiseize compound (WP 0928 00, Item 11)
- Cleaning compound (WP 0928 00, Item 19)

Equipment Condition

- Engine stopped (see your -10)
 - Carrier blocked (see your -10)
-

REMOVAL

CAUTION

Carrier should not be operated with bottom access cover off. This reduces air flow through radiator and draws dirt and debris into power plant compartment.

1. Remove four screws (1), washers (2), and bottom access cover (3) from hull.
2. If damaged, remove gasket (4) from cover (3).

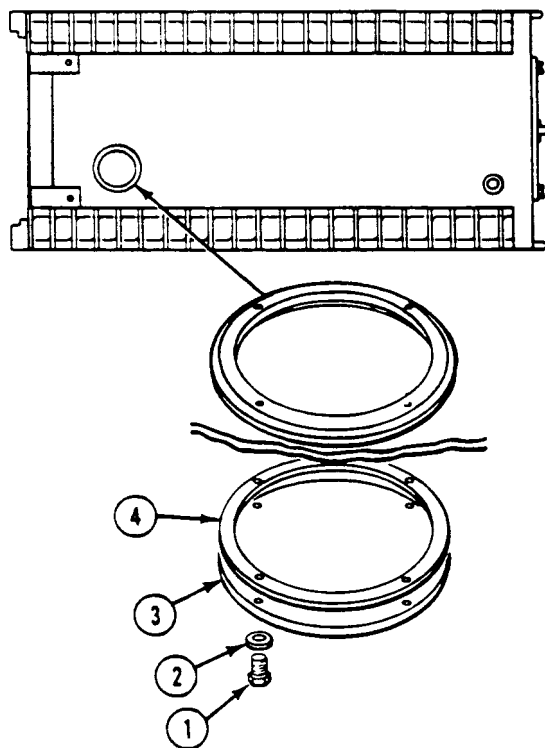

CLEANING

1. Clean cover and gasket mating surface with cleaning compound.

INSTALLATION

1. If gasket is being replaced, apply a light coat of adhesive to one side of new gasket. Allow adhesive to become tacky.
2. Place new gasket (1) on cleaned mating side of cover (2). Align mounting holes in cover and gasket.
3. Clean four screws (3) with cleaning compound. Apply antiseize compound sparingly to external threads of screws. Place cover (2) on hull. Secure with four screws (3) and washers (4). **TIGHTEN SCREWS TO 40-50 LB-FT (54-68 N·m) TORQUE.**

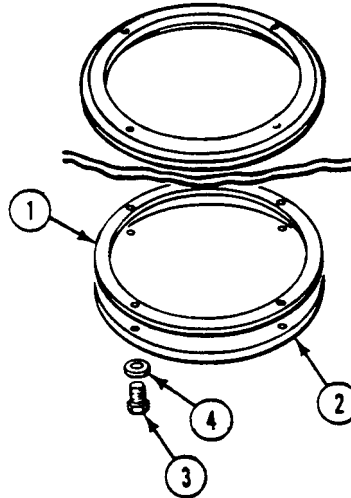
**END OF TASK**

REPLACE HULL DRAIN PLUG

0451 00

THIS WORK PACKAGE COVERS:

Removal (page 0451 00-1).
 Installation (page 0451 00-2).

INITIAL SETUP:

Maintenance Level

Unit

References

See your -10

Tools and Special Tools

General Mechanic's Tool Kit (WP 0926 00, Item 65)

Equipment Condition

Engine stopped (see your -10)

Carrier blocked (see your -10)

Rear floor plates removed (see Table of Contents)

Personnel Required

Unit Mechanic

REMOVAL

CAUTION

Carrier should not be operated with hull drain plug removed. This reduces air flow through radiator and draws dirt and debris into power plant compartment.

1. Remove nut (1) from screw (2).
2. Remove screw (2) and washer (3) from plug (4).
3. Remove plug (4) from hull.

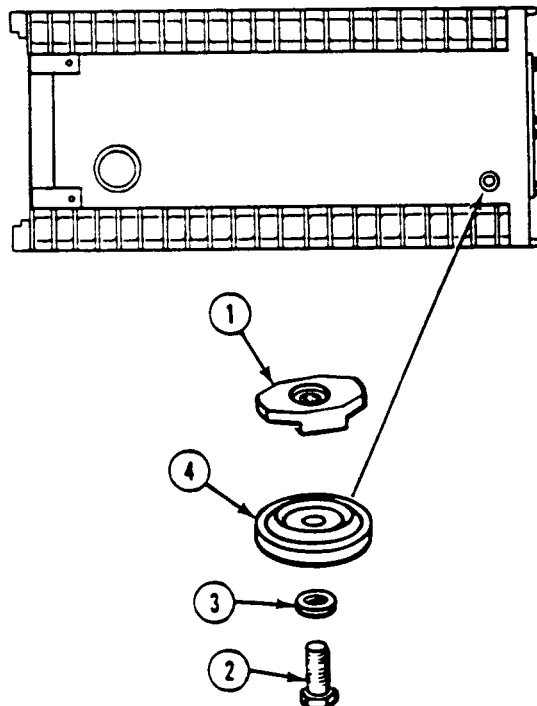

INSTALLATION

1. Install plug (4) in hull.
2. Install screw (2) and washer (3) in plug (4).
3. Install nut (1) on screw (2) far enough to expose threads above top of nut. Deform screw end so that nut can not be removed by hand.

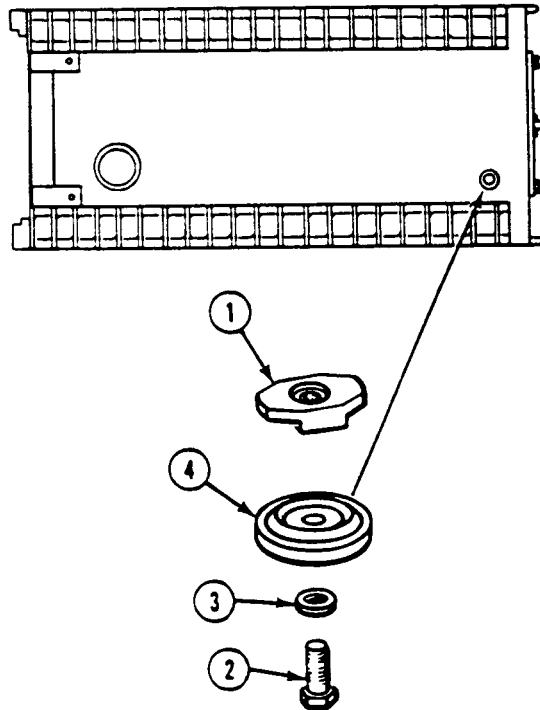
**FOLLOW-THROUGH STEPS**

1. Install rear floor plates (see Table of Contents).

END OF TASK

REPLACE FINAL DRIVE HULL DRAIN PLUGS

0452 00

THIS WORK PACKAGE COVERS:

Removal (page 0452 00-1).
 Installation (page 0452 00-2).

INITIAL SETUP:

Maintenance Level

Unit

Personnel Required

Unit Mechanic

Tools and Special Tools

General Mechanic's Tool Kit (WP 0926 00, Item 65)

References

See your -10

Materials/Parts

Antiseize compound (WP 0928 00, Item 11)

Equipment Condition

Engine stopped (see your -10)
 Carrier blocked (see your -10)

REMOVAL

1. Remove two drain plugs (1) from hull.

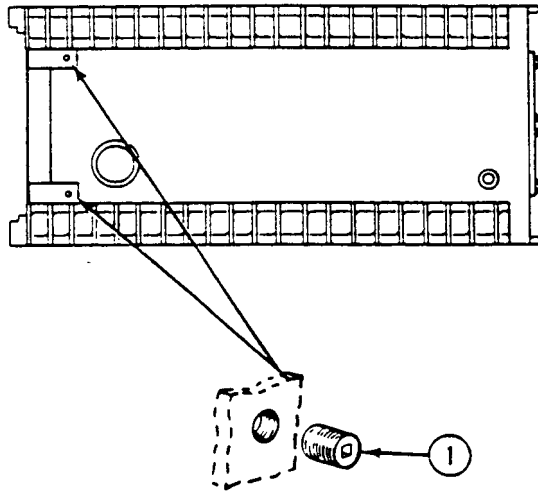

INSTALLATION

1. Coat threads of two drain plugs (1) with antiseize compound. Install two drain plugs in hull.

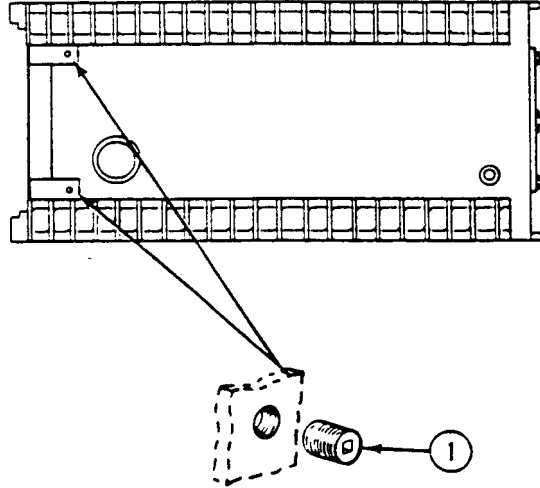
**END OF TASK**

REPLACE DRIVER'S COMPARTMENT FLOOR PLATES

0453 00**THIS WORK PACKAGE COVERS:**

Removal (page 0453 00-1).
Cleaning (page 0453 00-2).
Installation (page 0453 00-2).

INITIAL SETUP:Maintenance Level

Unit

Personnel Required

Unit Mechanic

Tools and Special Tools

General Mechanic's Tool Kit (WP 0926 00, Item 65)

References

See your -10

Materials/Parts

Cleaning Compound (WP 0928 00, Item 17)

Sealing compound (WP 0928 00, Item 50)

Equipment Condition

Engine stopped (see your -10)

Carrier blocked (see your -10)

REMOVAL

1. Remove nine screws (1), washers (2), and forward floor plate (3) from hull.
2. Remove eight screws (1), washers (2), and rear floor plate (4) from hull.

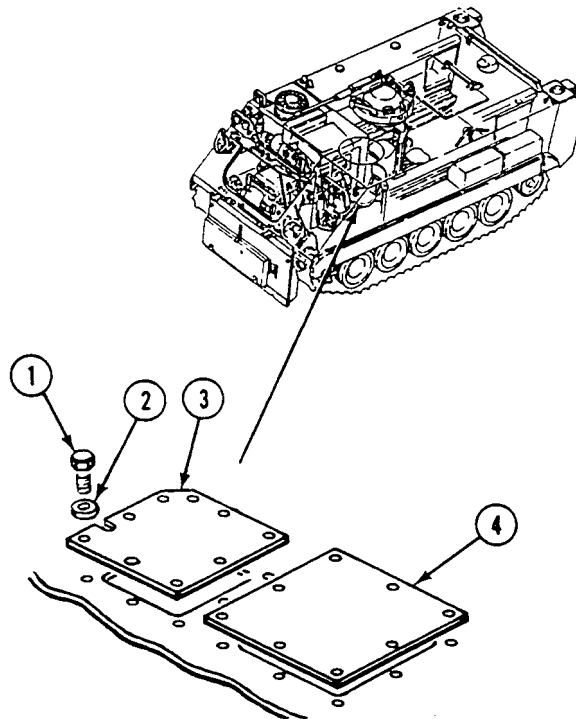

CLEANING

1. Clean floor plates and hull mating surface with cleaning compound.

INSTALLATION

1. Apply sealing compound to hull mating surface for floor plates.
2. Install rear floor plate (4). Secure with eight washers (2) and screws (1).
3. Install forward floor plate (3). Secure with nine washers (2) and screws (1).

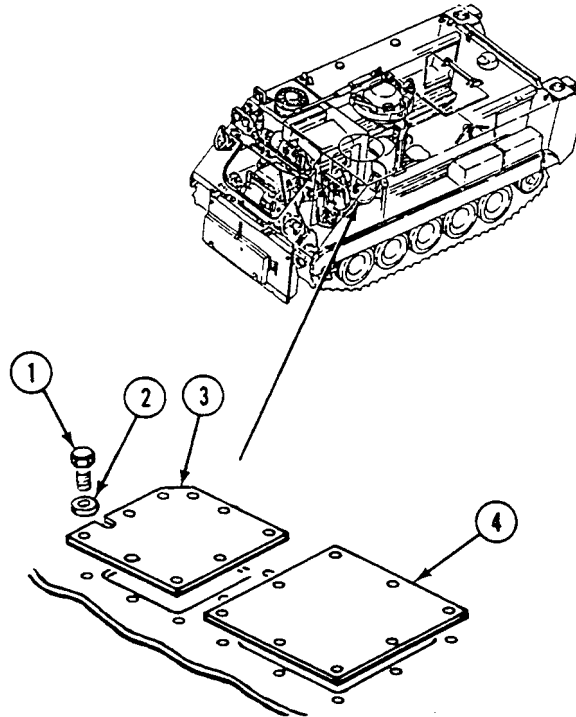
**END OF TASK**

REPLACE REAR COMPARTMENT AIR VENTILATOR

0454 00

THIS WORK PACKAGE COVERS:

- Removal (page 0454 00-1).
- Installation (page 0454 00-2).

INITIAL SETUP:

Maintenance Level

Unit

Personnel Required

Unit Mechanic

Tools and Special Tools

- General Mechanics Tool Kit (WP 0926 00, Item 65)
- Torque Wrench (WP 0926 00, Item 85)

References

See your -10

Materials/Parts

Gasket

Equipment Condition

- Engine stopped (see your -10)
- Carrier blocked (see your -10)
- Ramp lowered (see your -10)

REMOVAL

1. Remove three screws (1), cover (2), and three spacers (3) from hull mount.
2. Remove valve (4) and gasket (5) from cover (2). Discard gasket.

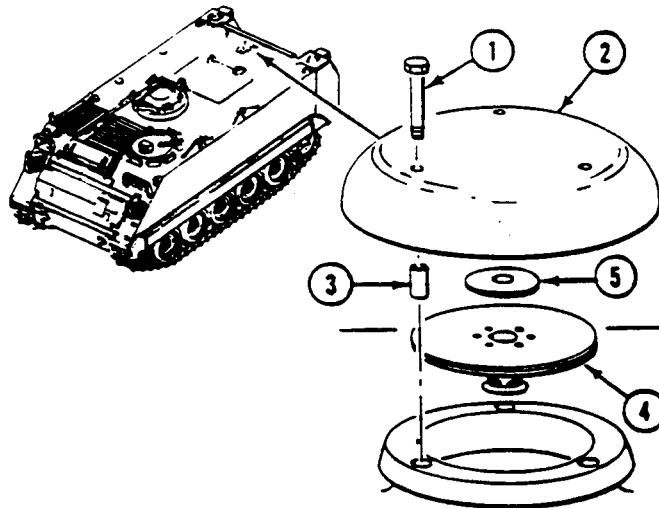

INSTALLATION

1. Install new gasket (5) and valve (4) on cover (2).
2. Align three spacers (3) and cover (2) with hull mount. Secure with three screws (1). TIGHTEN SCREWS TO 75-80 LB-FT (102-108 N·m) TORQUE.

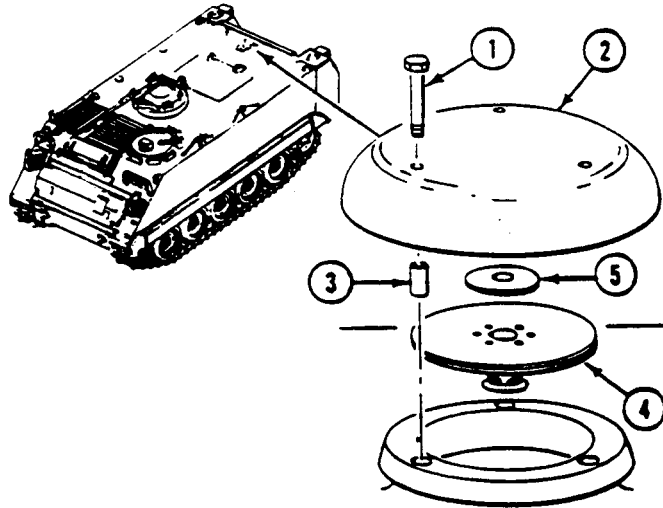
**FOLLOW-THROUGH STEPS**

1. Open and close air ventilator. Check that ventilator is installed right.
2. Start engine (see your -10).
3. Raise and lock ramp (see your -10).
4. Stop engine (see your -10).

END OF TASK

**REPLACE SMOKE GRENADE LAUNCHER GUARD, PLATE, AND BASE
(M113A3 AND M1059A3 ONLY)**

0455 00

THIS WORK PACKAGE COVERS:

Removal (page 0455 00-1).
Installation (page 0455 00-3).

INITIAL SETUP:

Maintenance Level

Unit

Personnel Required

Unit Mechanic

Tools and Special Tools

General Mechanic's Tool Kit (WP 0926 00, Item 65)

References

See your -10
TM 9-1040-267-20&P

Materials/Parts

Lockwasher (7)
Lockwasher (3)

Equipment Condition

Engine stopped (see your -10)
Carrier blocked (see your -10)

REMOVAL

NOTE

Left and right guard, plate, and base are replaced the same way.

**REPLACE SMOKE GRENADE LAUNCHER GUARD, PLATE, AND BASE (M113A3
AND M1059A3 ONLY) — Continued**

0455 00

1. Remove four screws (1), lockwashers (2), and guard (3) from front hull plate. Discard lockwashers.
2. Remove three screws (4), lockwashers (5), and base (6) from front hull plate. Discard lockwashers.
3. Remove three nuts (7), screws (8), lockwashers (9), washers (10), and plate (11) from base (6). Discard lockwashers.

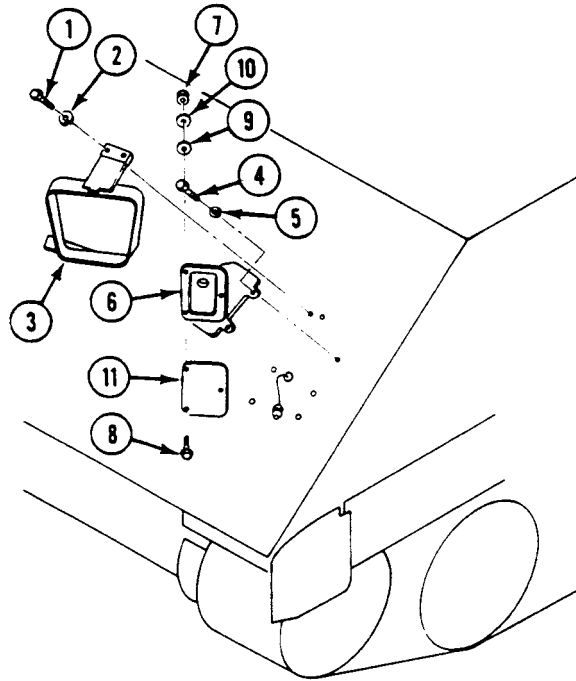

**REPLACE SMOKE GRENADE LAUNCHER GUARD, PLATE, AND BASE (M113A3
AND M1059A3 ONLY) — Continued**

0455 00

INSTALLATION

1. Install base (6) on hull front plate. Secure with three screws (4), and new lockwashers (5).
2. Install plate (11) on base (6). Secure with three nuts (7), screws (8), new lockwashers (9) and washers (10).

NOTE

If there is an interference problem between tubes and guard, shim the two top guard holes using washers.

3. Install guard (3) on front hull plate. Secure with four screws (1) and new lockwashers (2).

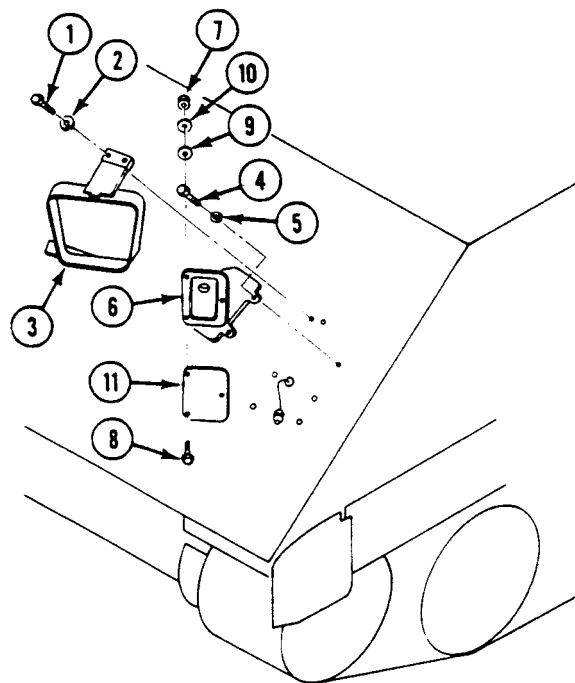
**END OF TASK**

REPLACE WATER BARRIER (M113A3, M577A3, AND M1068A3 ONLY)

0456 00

THIS WORK PACKAGE COVERS:

Removal (page 0456 00-1).
 Installation (page 0456 00-3).

INITIAL SETUP:

Maintenance Level

Unit

References

See your -10

Tools and Special Tools

General Mechanic's Tool Kit (WP 0926 00, Item 65)

Equipment Condition

Engine stopped (see your -10)

Personnel Required

Unit Mechanic

Carrier blocked (see your -10)

REMOVAL

1. Release two straps (1) securing water barrier curtain (2) in stowed position. Unfold curtain.

- Remove four screws (3) and washers (4) that secure water barrier curtain (2) to hull. Remove curtain.

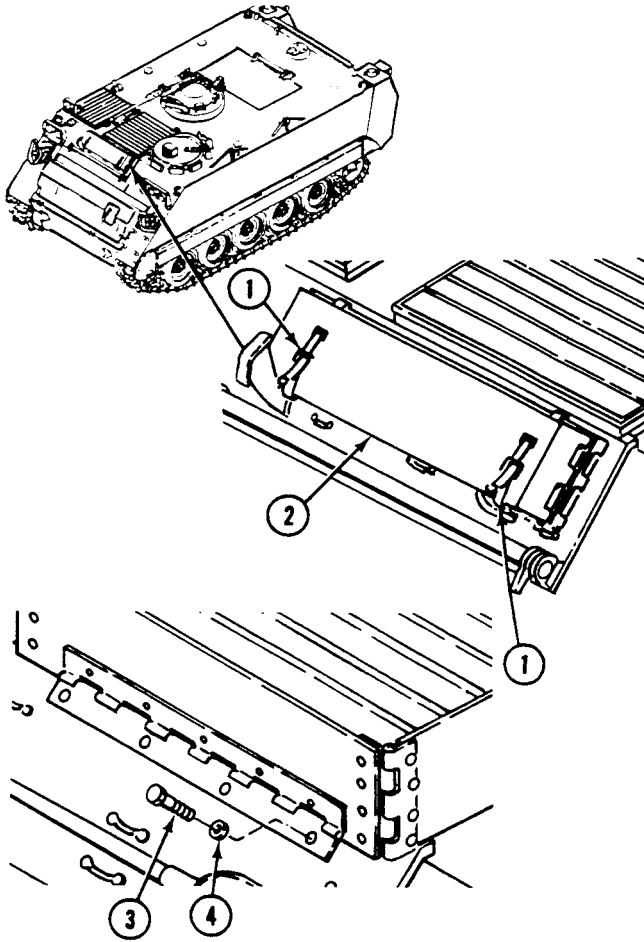

INSTALLATION

1. Install water barrier curtain (2) on hull. Secure curtain with four washers (4) and screws (3).
2. Fold water barrier curtain (2) to stowed position and secure with two straps (1).

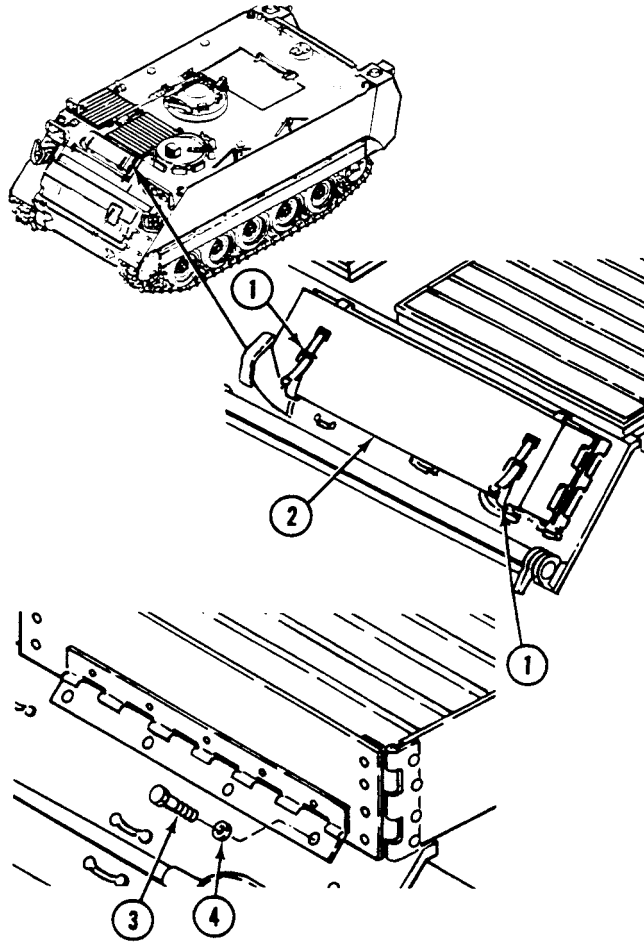
**END OF TASK**

REPLACE WATER BARRIER LOOP AND STRAP (M113A3, M577A3, AND M1068A3 ONLY)

0457 00

THIS WORK PACKAGE COVERS:

Removal (page 0457 00-1).
 Installation (page 0457 00-2).

INITIAL SETUP:

Maintenance Level

Unit

References

See your -10

Tools and Special Tools

General Mechanic's Tool Kit (WP 0926 00, Item 65)

Equipment Condition

Engine stopped (see your -10)

Personnel Required

Unit Mechanic

Carrier blocked (see your -10)

REMOVAL

1. Remove strap (1) from loop (2).
2. Remove two screws (3), washers (4), and loop (2) from carrier.

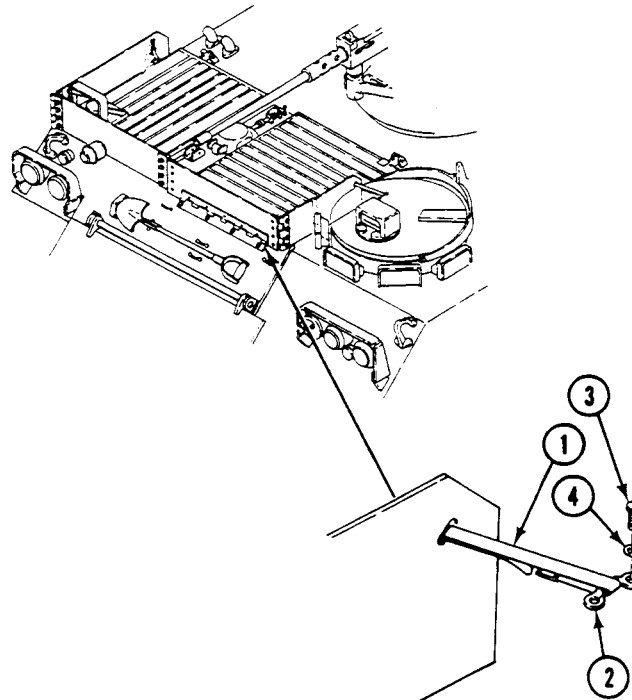

REPLACE WATER BARRIER LOOP AND STRAP (M113A3, M577A3, AND M1068A3 ONLY) — Continued

0457 00

INSTALLATION

1. Install loop (2) on carrier. Secure with two washers (4) and screws (3).
2. Install strap (1) on loop (2).

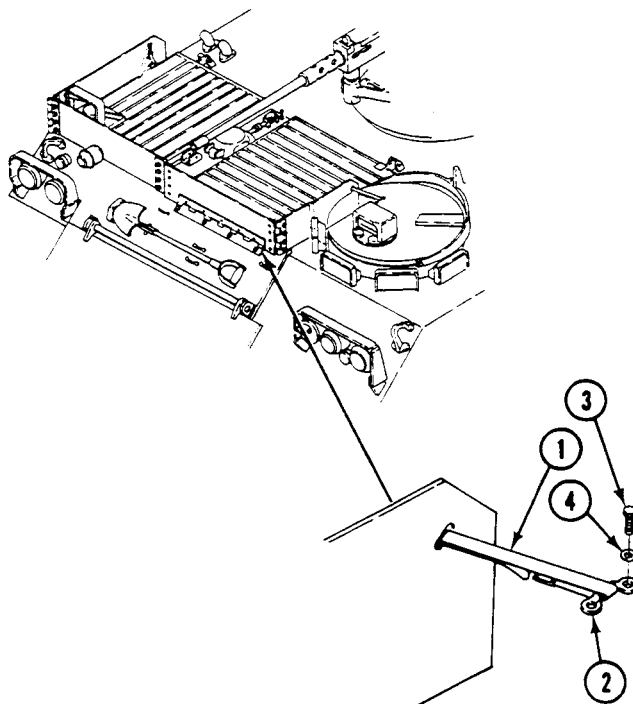
**END OF TASK**

REPLACE TRIM VANE

0458 00

THIS WORK PACKAGE COVERS:

Removal (page 0458 00-1).
 Installation (page 0458 00-2).

INITIAL SETUP:

Maintenance Level

Unit

Personnel Required

Unit Mechanic
 Helper (H)

Tools and Special Tools

General Mechanic's Tool Kit (WP 0926 00, Item 65)

References

See your -10

Materials/Parts

Locknut (4)

Equipment Condition

Engine stopped (see your -10)
 Carrier blocked (see your -10)
 Trim vane stowed (see your -10)

REMOVAL

1. Remove two outer locknuts (1) and screws (2) from hinges (3). Discard locknuts.
2. (H) Lower trim vane (see your -10).
3. Remove two inner locknuts (4) and screws (5) from hinges (6). Remove trim vane from carrier. Have helper assist. Discard locknuts.
4. Remove hinges from trim vane and retain.

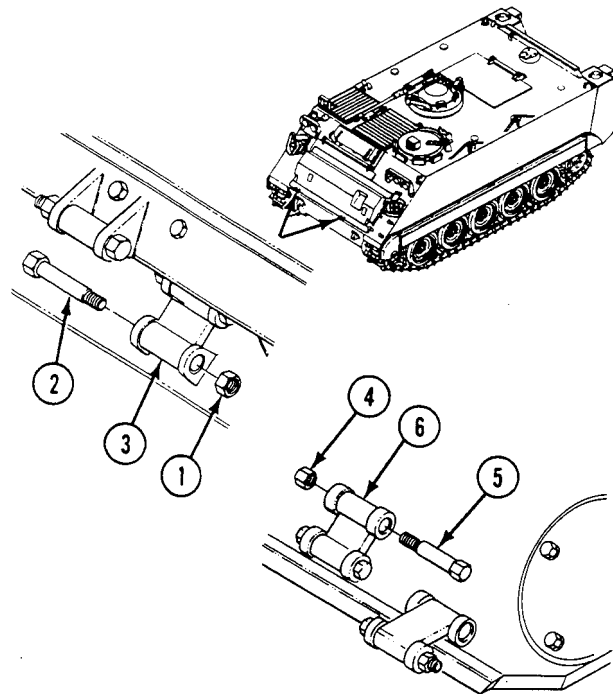

INSTALLATION

1. Install hinges on trim vane.
2. Place trim vane on carrier and align four hinges. Have helper assist. Secure two inner hinges (6) with two screws (5) and new locknuts (4).
3. (H) Stow trim vane (see your -10).
4. Secure two outer hinges (3) with two screws (2) and new locknuts (1).

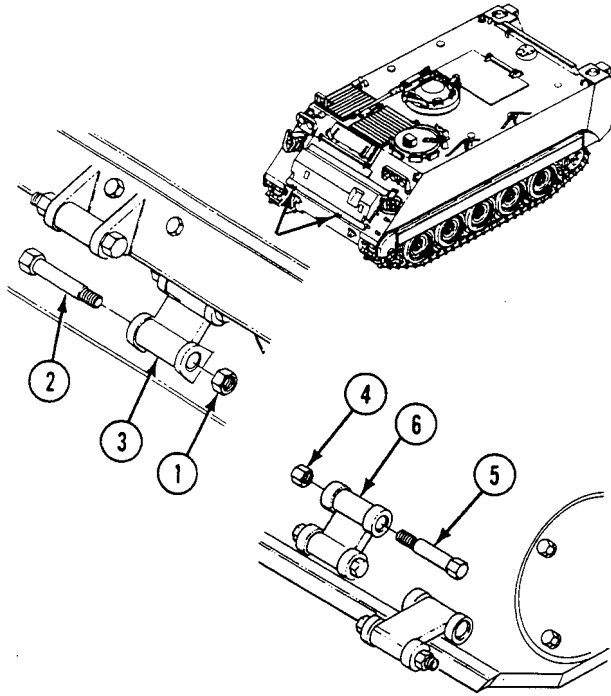
**END OF TASK**

REPAIR TRIM VANE (ALL EXCEPT M58)

0459 00

THIS WORK PACKAGE COVERS:

- Disassemble (page 0459 00-1).
 - Inspection and Repair (page 0459 00-2).
 - Assemble (page 0459 00-3).
-

INITIAL SETUP:

Maintenance Level

Unit

Personnel Required

Unit Mechanic

Tools and Special Tools

General Mechanic's Tool Kit (WP 0926 00, Item 65)

Equipment Condition

Trim vane removed (WP 0458 00)

Materials/Parts

- Locknut (31)
 - Locknut (9)
 - Locknut (2)
-

DISASSEMBLY

1. Remove seven locknuts (1), 14 washers (2), and seven screws (3) from front pod (4), rear pod (5), and trim vane (6). Discard locknuts.

REPAIR TRIM VANE (ALL EXCEPT M58) — Continued

0459 00

2. Remove six locknuts (7), washers (8), screws (9) and front pod (4) from trim vane (6). Discard locknuts.
3. Remove six locknuts (10), 12 washers (11), six screws (12), and rear pod (5) from trim vane (6). Discard locknuts.
4. Remove three locknuts (13), washers (14), bumpers (15), and six washers (16) from trim vane (6). Discard locknuts.
5. Remove two locknuts (17), screws (18), and hinges (19) from trim vane (6). Discard locknuts.
6. Remove seven locknuts (20), screws (21), and lower stiffener (22) from trim vane (6). Discard locknuts.
7. Remove five locknuts (23), screws (24), and upper stiffener (25) from vane (6). Discard locknuts.
8. Remove six locknuts (26), screws (27), two plates (28), and release assembly (29) from trim vane (6). Discard locknuts.

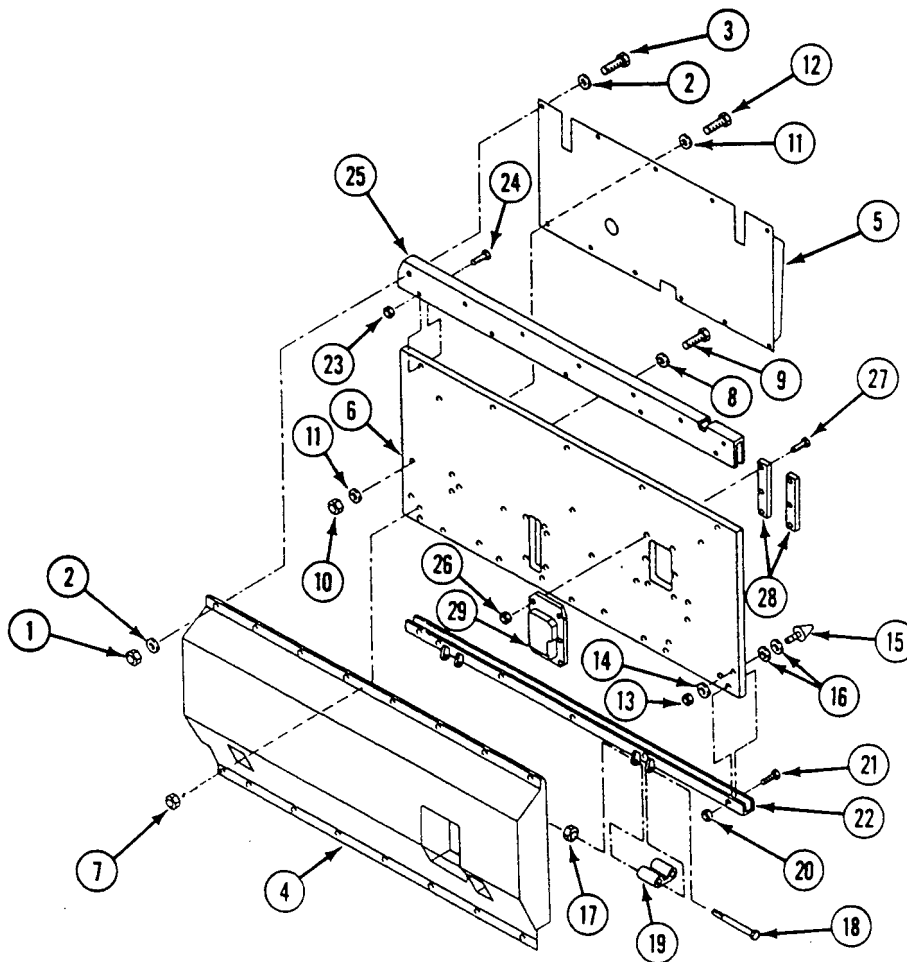

INSPECTION-ACCEPTANCE AND REJECTION CRITERIA

1. Check inside of floatation pod section. If foam filler is cracked or missing, notify your supervisor. Check metal for cracks. Check flatness with straight edge. Use a cross-cut saw to trim off any foam that extends beyond edge of pod.

ASSEMBLY

1. Install release assembly (1) in trim vane (2). Secure with two plates (3), six screws (4), and new locknuts (5).
2. Install upper stiffener (6) on trim vane (2). Secure with five screws (7) and new locknuts (8).
3. Install lower stiffener (9) on trim vane (2). Secure with seven screws (10) and new locknuts (11).
4. Install two hinges (12) on lower stiffener (9). Secure with two screws (13) and new locknuts (14).
5. Install three bumpers (15) with six washers (16) on trim vane (2). Secure with three washers (17) and new locknuts (18).
6. Install rear pod (19), 12 washers (20), six screws (21), and new locknuts (22) on trim vane (2).
7. Install front pod (23), six washers (24) on plywood side, screws (25), and new locknuts (26) on trim vane (2).
8. Install 14 washers (27), seven screws (28), and new locknuts (29) on front pod (23), trim vane (2), and rear pod (19).

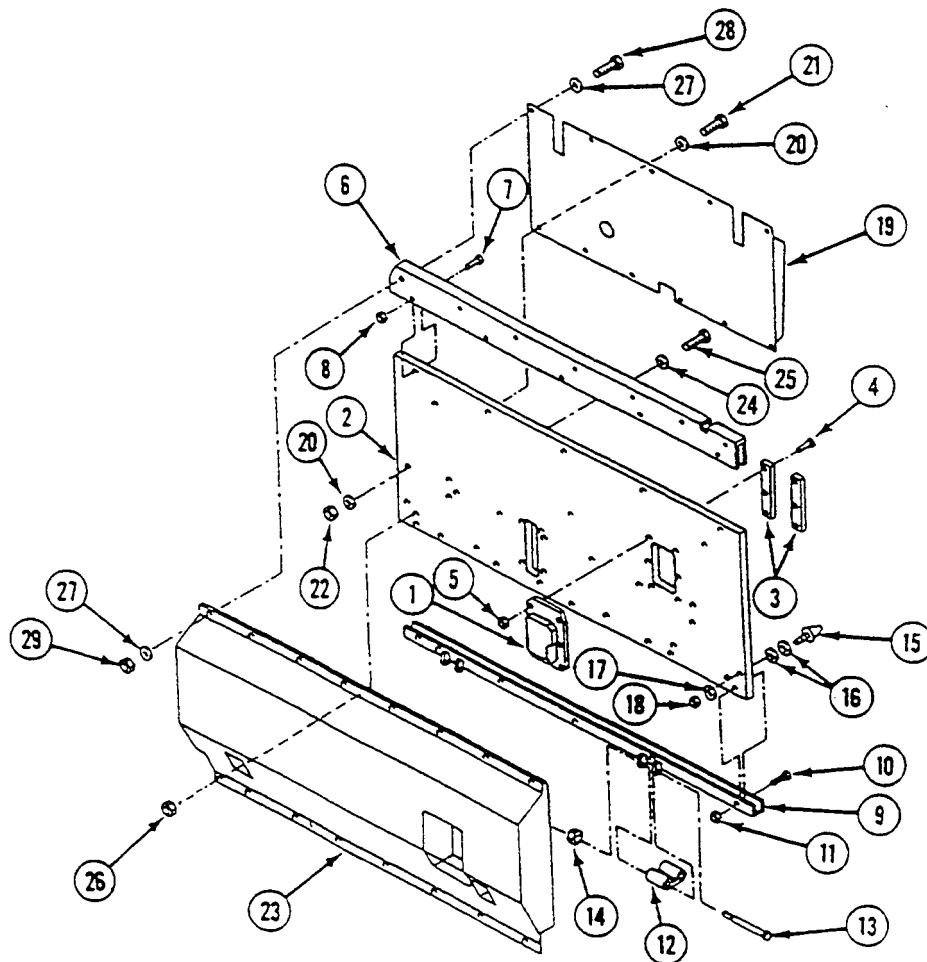
**FOLLOW-THROUGH STEPS**

1. Install trim vane (WP 0458 00).

END OF TASK

REPAIR TRIM VANE (M58 ONLY)

0460 00

THIS WORK PACKAGE COVERS:

Disassemble (page 0460 00-1)
 Assemble (page 0460 00-3)

INITIAL SETUP:

Maintenance Level

Unit

Personnel Required

Unit Mechanic

Tools and Special Tools

General Mechanic's Tool Kit (WP 0926 00, Item 65)

Equipment Condition

Trim vane removed (WP 0458 00)

Materials/Parts

Locknut (14)
 Locknut (10)
 Locknut (4)

DISASSEMBLY

1. Remove three locknuts (1), washers (2), and bumpers (3) from trim vane (4). Discard locknuts.

2. Remove four locknuts (5), screws (6), and hinges (7) from trim vane (4). Discard locknuts.
3. Remove seven locknuts (8), screws (9), and lower stiffener (10) from trim vane (4). Discard locknuts.
4. Remove two locknuts (11), washers (12), and bumpers (13) from trim vane (4). Discard locknuts.
5. Remove three locknuts (14), screws (15), and upper stiffener (16) from trim vane (4). Discard locknuts.
6. Remove six locknuts (17), screws (18), two plates (19), and release assembly (20) from trim vane (4). Discard locknuts.
7. Remove four locknuts (21), washers (22), bracket (23), and screws (24) from trim vane (4). Discard locknuts.

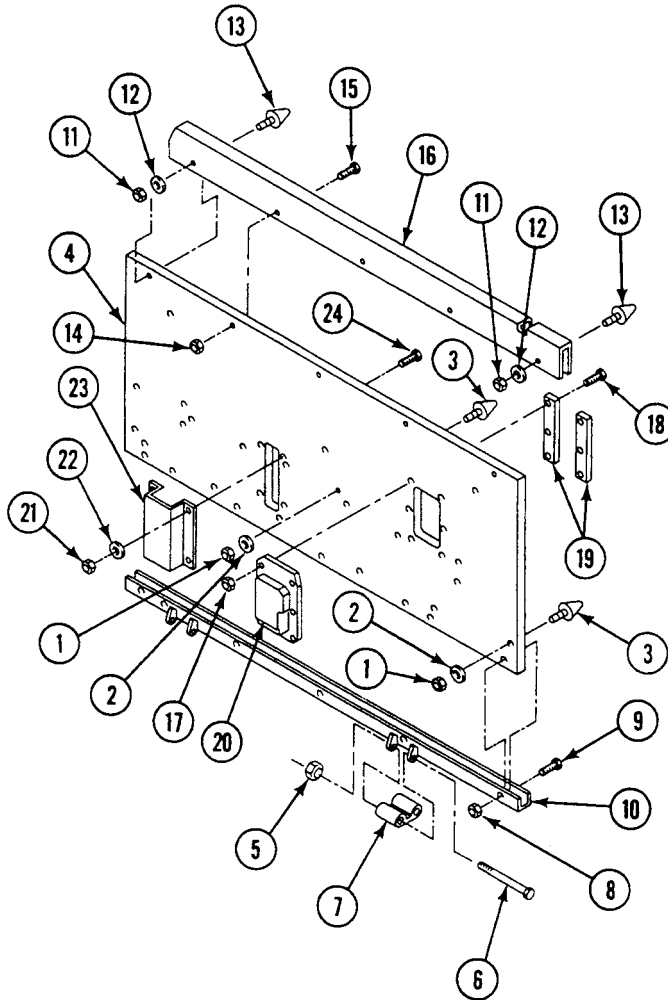

ASSEMBLY

1. Install bracket (1) on trim vane (2). Secure with four screws (3), washers (4), and new locknuts (5).
2. Install release assembly (6) in trim vane (2). Secure with two plates (7), six screws (8), and new locknuts (9).
3. Install upper stiffener (10) on trim vane (2). Secure with six screws (11) and new locknuts (12).
4. Install two bumpers (13) on trim vane (2). Secure with two washers (14) and new locknuts (15).
5. Install lower stiffener (16) on trim vane (2). Secure with six screws (17) and new locknuts (18).
6. Install two hinges (19) on lower stiffener (16). Secure with two screws (20) and new locknuts (21).
7. Install three bumpers (21) on trim vane (2). Secure with three washers (22) and new locknuts (23).

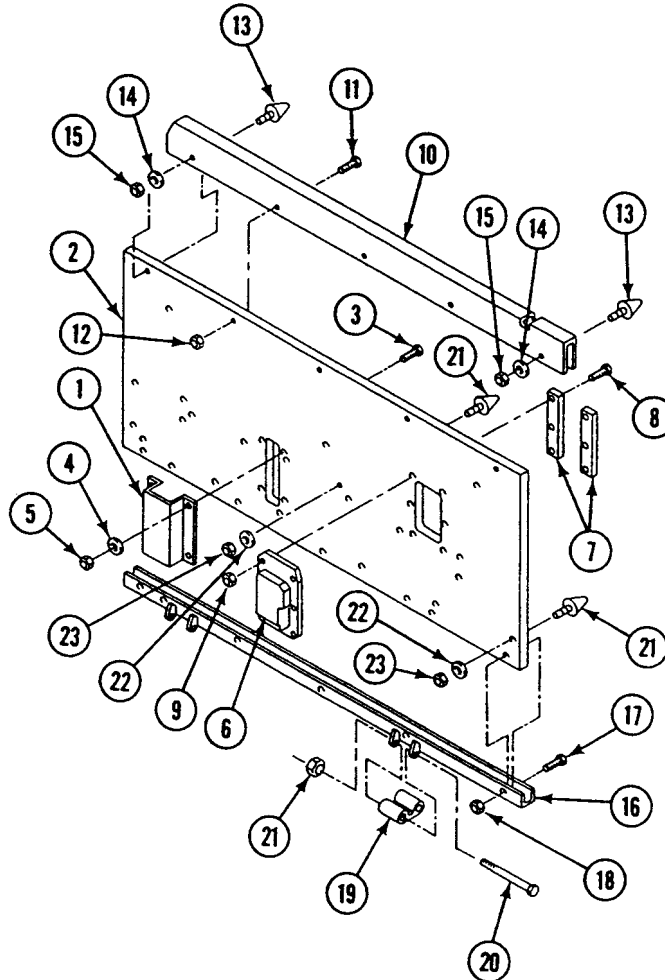

FOLLOW-THROUGH STEPS

1. Install trim vane (WP 0458 00).

END OF TASK

REPAIR TRIM VANE CONTROL LINKAGE

0461 00

THIS WORK PACKAGE COVERS:

Disassembly (page 0461 00-1).
 Assembly (page 0461 00-3).

INITIAL SETUP:

Maintenance Level

Unit

Personnel Required

Unit Mechanic

Tools and Special Tools

General Mechanic's Tool Kit (WP 0926 00, Item 65)
 Torque Wrench (WP 0926 00, Item 85)

References

See your -10

Materials/Parts

Cotter pin
 Locknut

Equipment Condition

Engine stopped (see your -10)
 Carrier blocked (see your -10)
 Trim vane lowered (see your -10)

DISASSEMBLY

1. Remove cotter pin (1) from pin (2). Remove pin (2) from clevis (3) and pivot bracket (4). Discard cotter pin.

2. Remove two screws (5), washers (6), and pivot bracket (4) from hull.
3. Disconnect spring (7) from catch (8) and bracket (9).
4. Remove clevis (3), bracket (9), and nut (10) from eyebolt (11).
5. Remove locknut (12), screw (13), catch (8), and eyebolt (11) from extension (14). Remove extension. Discard Locknut.

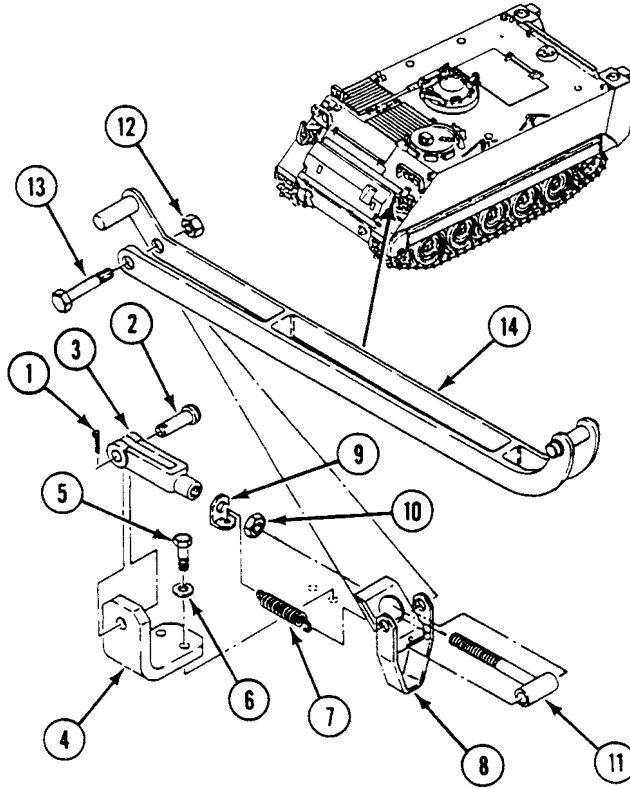

ASSEMBLY

1. Install eyebolt (11) and catch (8) on extension (14). Secure with screw (13) and new locknut (12).
2. Install nut (10), bracket (9), and clevis (3) on eyebolt (11).
3. Install spring (7) on catch (8) and bracket (9).
4. Install pivot bracket (4) on hull. Secure with two screws (5) and washers (6). Tighten screws to 32-34 ft-lb (43-46 N.m) torque.
5. Position trim vane control linkage on carrier with clevis(3) aligned with pivot bracket (4).
6. Install pin (2) in clevis (3) and pivot bracket (4). Secure with new cotter pin (1).
7. Adjust clevis (3) to provide overcenter lock in retracted position.
8. Adjust trim vane quick release to provide overcenter lock in retracted position.

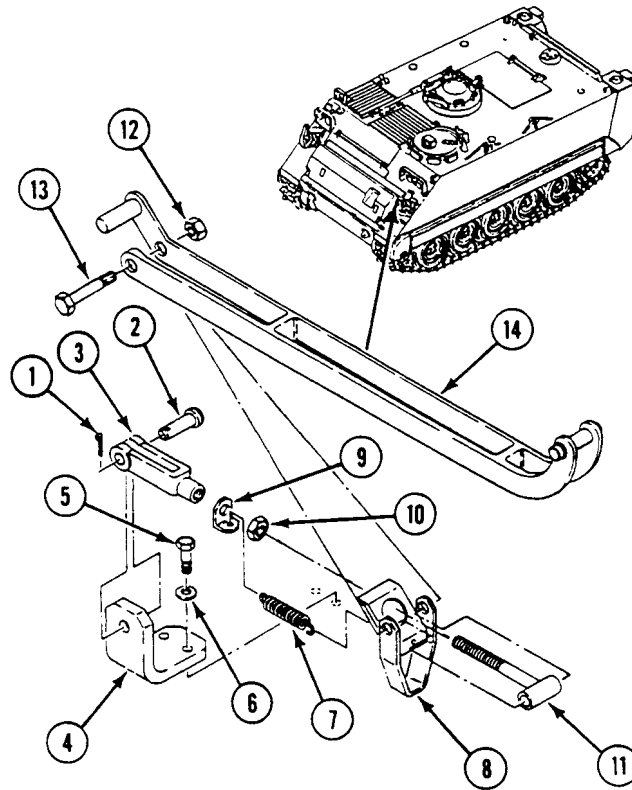
**END OF TASK**

REPLACE TRIM VANE RELEASE

0462 00

THIS WORK PACKAGE COVERS:

- Removal (page 0462 00-1).
- Installation (page 0462 00-1).
- Adjustment (page 0462 00-2).

INITIAL SETUP:

Maintenance Level

Unit

Personnel Required

Unit Mechanic

Tools and Special Tools

General Mechanic's Tool Kit (WP 0926 00, Item 65)

References

See your -10

Materials/Parts

- Cotter pin
- Cotter pin
- Locknut (6)

Equipment Condition

- Engine stopped (see your -10)
- Carrier blocked (see your -10)
- Trim vane lowered (see your -10)

REMOVAL

1. Remove six locknuts (1), screws (2), and two plates (3) from trim vane (4). Discard locknuts.
2. Remove trim vane release (5) from trim vane (4).

INSTALLATION

1. Place two plates (3) and trim vane release (5) on trim vane (4). Secure with six screws (2) and new locknuts (1).

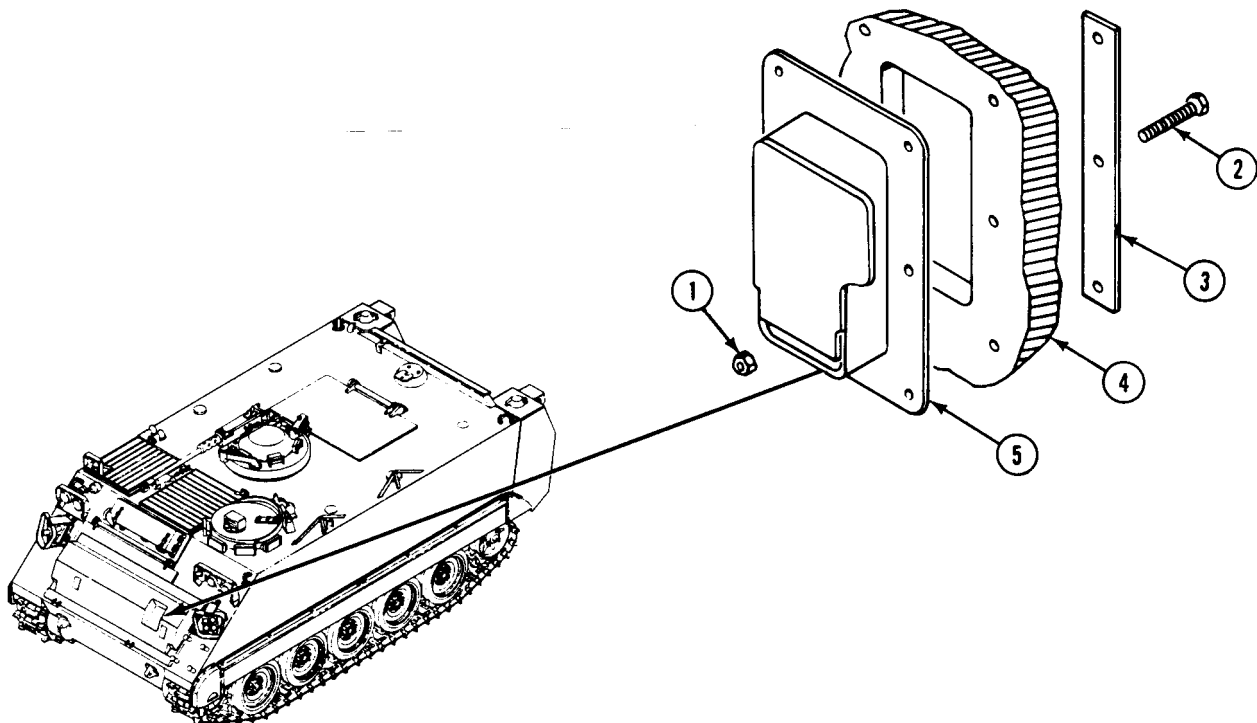

ADJUSTMENT

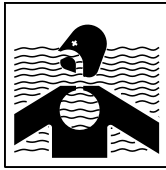
WARNING

Carrier can sink and personnel can be trapped inside and drown if trim vane collapses during water operation. Improper adjustment of trim vane release may allow extension linkage to come out of trim vane release and cause collapse of trim vane.

WARNING

Trim vane can fall and injure personnel. Make sure trim vane zone is clear when you lower or stow trim vane.

NOTE

Several adjustments of clevis rod ends on extension linkage and trim vane release may be necessary to obtain overcenter lock in retracted position.

1. Stow trim vane (see your -10).

REPLACE TRIM VANE RELEASE — Continued

0462 00

2. Manually move upper edge of trim vane (1) forward and rearward to check trim vane for excess movement in stowed position. If trim vane moves too much or is not secure in stowed position, go to Step 3.
3. Remove cotter pin (2) and pin (3) from clevis rod end (4) and bracket (5). Loosen nut (6) and turn clevis rod end to change length of extension linkage. Tighten nut. Retain cotter pin until adjustments are complete.
4. Install clevis rod end (4), pin (3), and retained cotter pin (2) on bracket (5). Check that extension linkage provides overcenter lock in retracted position.
5. Check trim vane (1) for excess movement in stowed position. If trim vane moves too much or is not secure in stowed position, go to Step 6.

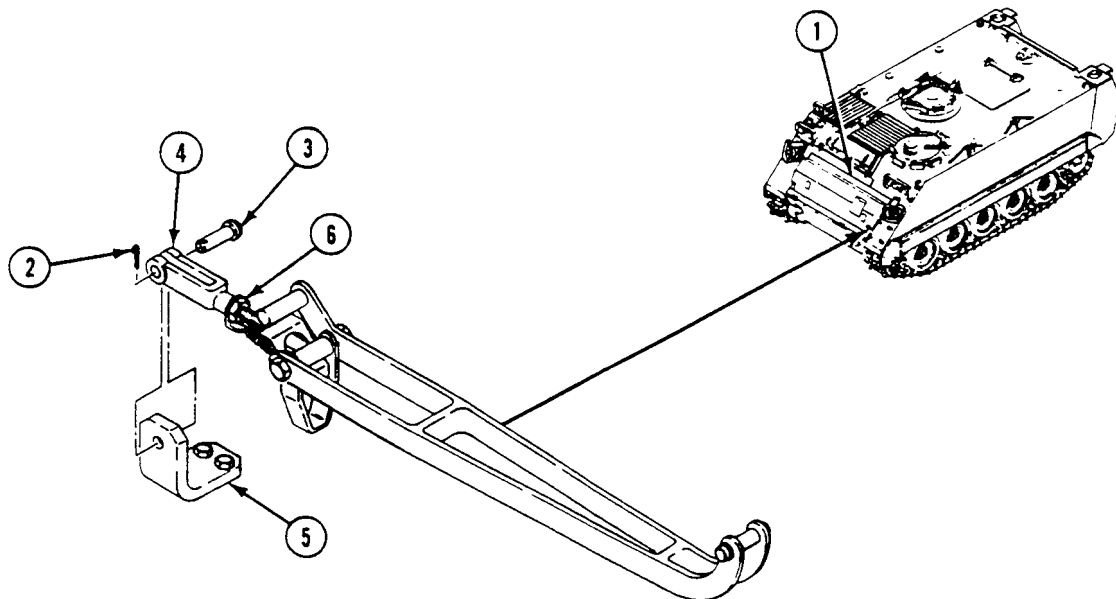

6. Lower trim vane (see your -10) and secure in safe position for access to trim vane release handle (1).
7. Lift and secure spring-loaded trim vane release handle (1) for access to internal parts.
8. Remove cotter pin (2), straight pin (3), and clevis rod end (4) from trim vane release (5). Retain cotter pin until adjustments are complete.
9. Loosen nut (6) and turn clevis rod end (4) to change length of clevis rod. Tighten nut.
10. Install clevis rod end (4), straight pin (3), and retained cotter pin (2) on trim vane release linkage (5).
11. Check that trim vane release linkage (5) provides overcenter lock in retracted position. Repeat adjustment procedure for clevis rod ends on extension linkage and trim vane release, if necessary.
12. Remove and discard retained cotter pin (7) from pin (8) on extension linkage clevis rod end (9). Install new cotter pin (7).

REPLACE TRIM VANE RELEASE — Continued**0462 00**

13. Remove and discard retained cotter pin (2) from straight pin (3) on trim vane release linkage (5). Install new cotter pin (2).

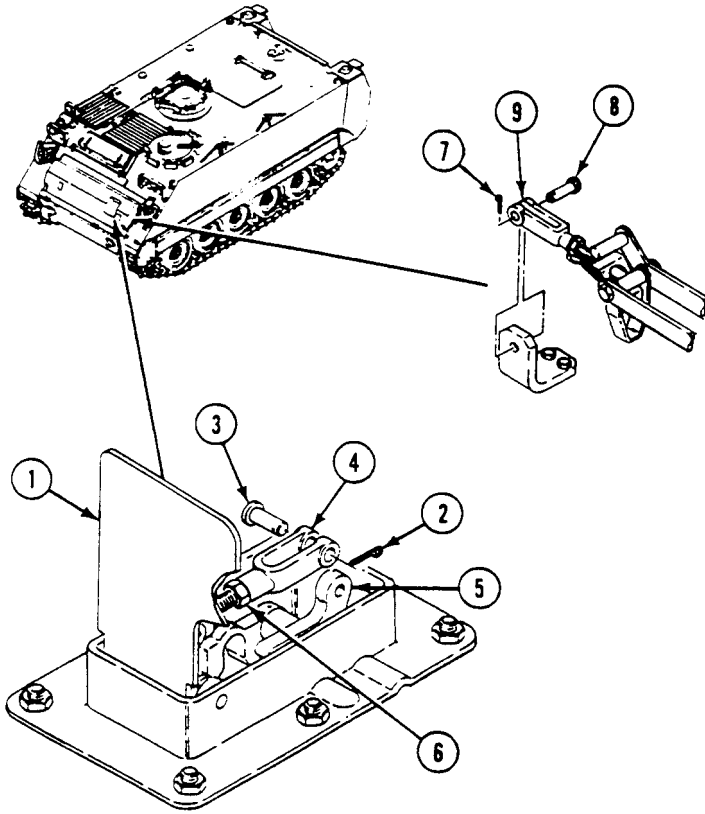
**FOLLOW-THROUGH STEPS**

1. Raise trim vane (see your -10).

END OF TASK

REPAIR TRIM VANE RELEASE

0463 00

THIS WORK PACKAGE COVERS:

- Disassembly (page 0463 00-1)
- Assembly (page 0463 00-3)

INITIAL SETUP:

Maintenance Level
Unit

Personnel Required
Unit Mechanic

Tools and Special Tools
General Mechanic's Tool Kit (WP 0926 00, Item 65)

Equipment Condition

Materials/Parts
Cotter pin (4)

Trim vane release removed from trim vane (WP 0462 00)

DISASSEMBLY

1. Remove cotter pin (1), straight pin (2), and cover (3) from housing (4). Discard cotter pin.
2. Remove cotter pin (5), headed pin (6), and cover (3) from clevis (7). Discard cotter pin.

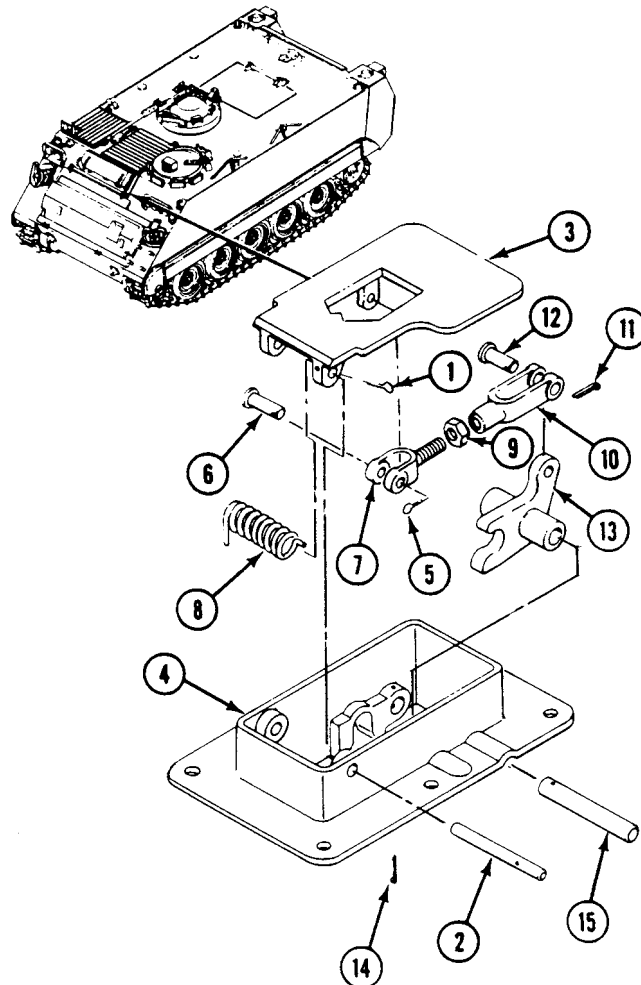

REPAIR TRIM VANE RELEASE — Continued

0463 00

3. Remove cover (3) and spring (8) from housing (4).
4. Remove clevis (7) and nut (9) from clevis (10).
5. Remove cotter pin (11), headed pin (12), and clevis (10) from trim vane release (13). Discard cotter pin.
6. Remove cotter pin (14), straight pin (15), and release (13) from housing (4). Discard cotter pin.

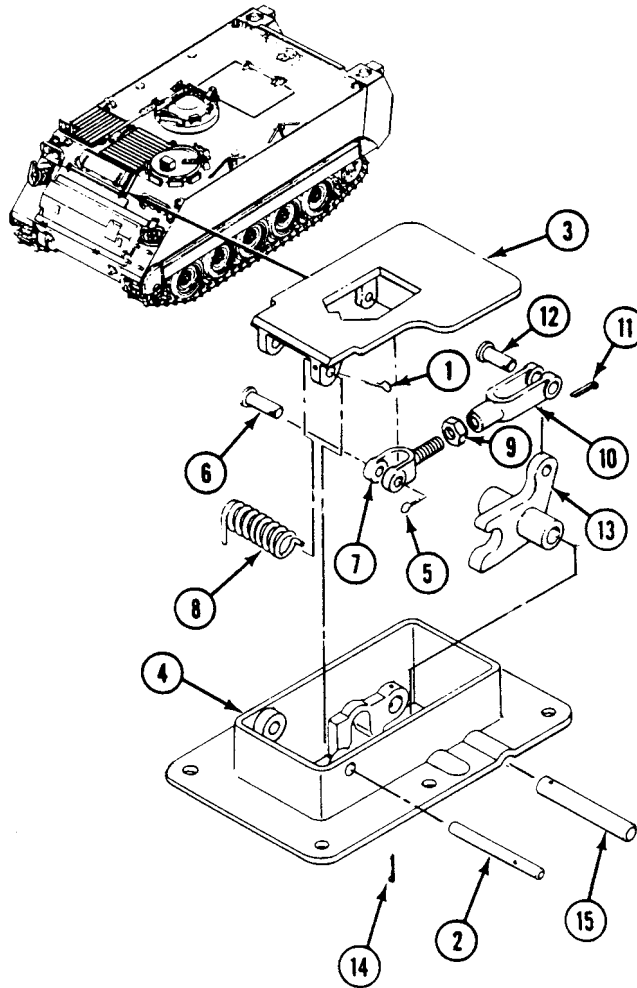

ASSEMBLY

1. Install clevis (1) on cover (2). Secure with headed pin (3) and new cotter pin (4).
2. Install nut (5) and clevis (6) on clevis (1).
3. Install release (7) on housing (8). Secure with straight pin (9) and new cotter pin (10).
4. Place spring (11) in housing (8). Secure cover (2) to housing with straight pin (12) and new cotter pin (13).
5. Raise cover (2). Install clevis (6) on release (7). Secure with headed pin (14) and new cotter pin (15).

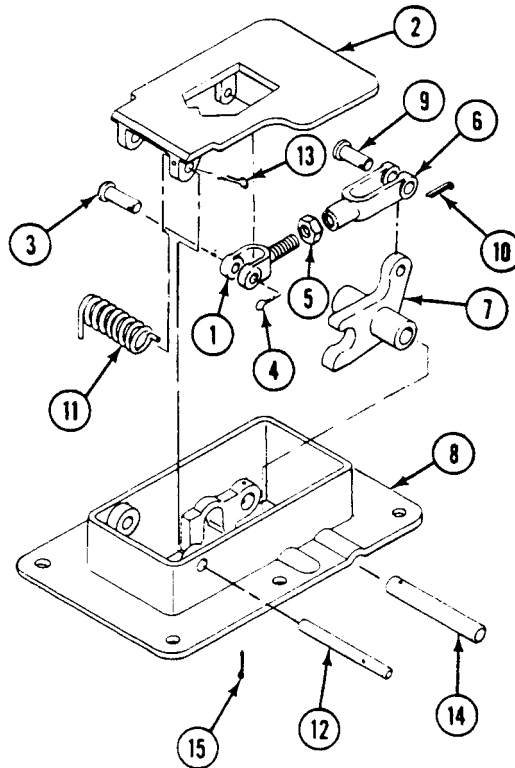
**FOLLOW-THROUGH STEPS**

1. Install trim vane release on trim vane (WP 0462 00).

END OF TASK

RAISE AND LOWER POWER PLANT GRILLE

0464 00

THIS WORK PACKAGE COVERS:

Raise (page 0464 00-2).
 Lower (page 0464 00-10).

INITIAL SETUP:

Maintenance Level

Unit

Tools and Special Tools

General Mechanic's Tool Kit (WP 0926 00, Item 65)
 Socket Adapter (WP 0926 00, Item 1)
 Caulking Gun (WP 0926 00, Item 17)
 Torque Wrench (WP 0926 00, Item 86)

Materials/Parts

Caulking compound (WP 0928 00, Item 14)

Personnel Required

Unit Mechanic
 Helper (H)

References

See your -10
 TM9-6115-664-13&P

Equipment Condition

Engine stopped (see your -10)
 Carrier blocked (see your -10)
 Trim vane lowered (see your -10)
 Power plant front access door opened (see your -10)
 Driver's power plant access panel removed
 (WP 0441 00)
 Power plant upper rear access panel removed
 (WP 0439 00)
 Cooling system drained (WP 0227 00)
 Ventilating fan drive belt removed (WP 0243 00)
 Muffler extension and cap removed (WP 0223 00)
 Coolant heater exhaust removed (WP 0724 00) if coolant
 heater kit is installed.
 4.2 Kilowatt generator set removed (M577A3 and
 M1068A3 ONLY) (see your -10)
 or 5.0 Kilowatt generator set removed
 TM9-6115-664-13&P

PLACING IN SERVICE**RAISE**

The grille assembly will swing when screws are removed. To avoid injury, do not stand in front of or behind grille assembly.

Damaged lifting slings can fail with load. Soldiers can be killed or injured. Inspect all slings before use. Do not use damaged slings.

Grill and access cover are very heavy. Use extreme caution when lifting, blocking, and lowering assembly. Allowing assembly to fall could cause death or injury.

CAUTION

To prevent damage to fan, radiator, and elbows, lower grille onto wood blocks or suitable frame that will support edge of grille.

Use chain and lifting device capable of lifting and holding 2000 lbs (908 kg) securely.

The power plant door is heavy. If necessary, use extra helpers and straps/chains to guide and control power plant door.

1. Loosen two clamps (1) on hose (2). Slide clamps and hose away from radiator inlet elbow (3).

2. Loosen two clamps (4) on hose (5). Slide clamps and hose away from radiator outlet elbow (6).

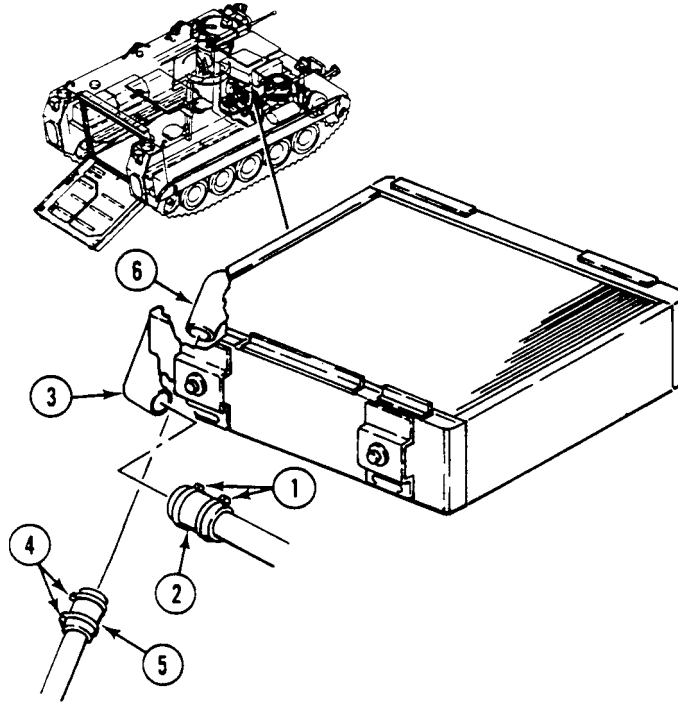

3. Loosen three clamps (1), (2), and (3) on hoses (4)(5)(6). Disconnect hoses from auxiliary tank (7).
4. Disconnect auxiliary fluid level detector (8) from cable (9).

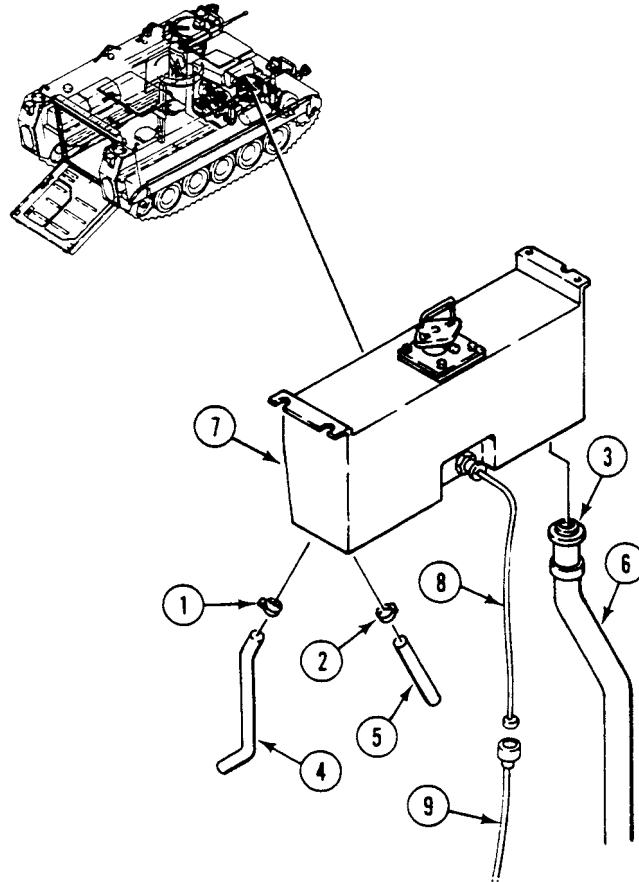

5. Disconnect cannon plug of headlight wiring harness (10) from hull (11).

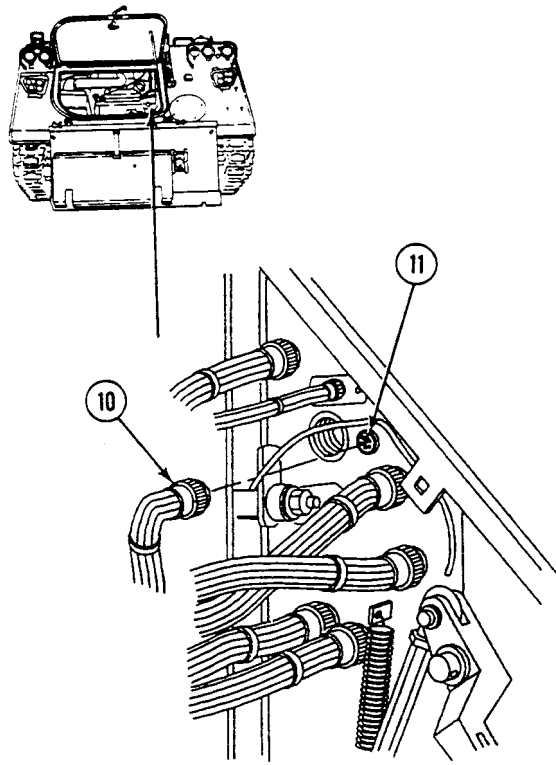

- Loosen two clamps (12)(13) on exhaust elbows (14)(15). Slide one clamp (12) on to muffler inlet pipe (16) and the other clamp (13) on to exhaust elbow (15).

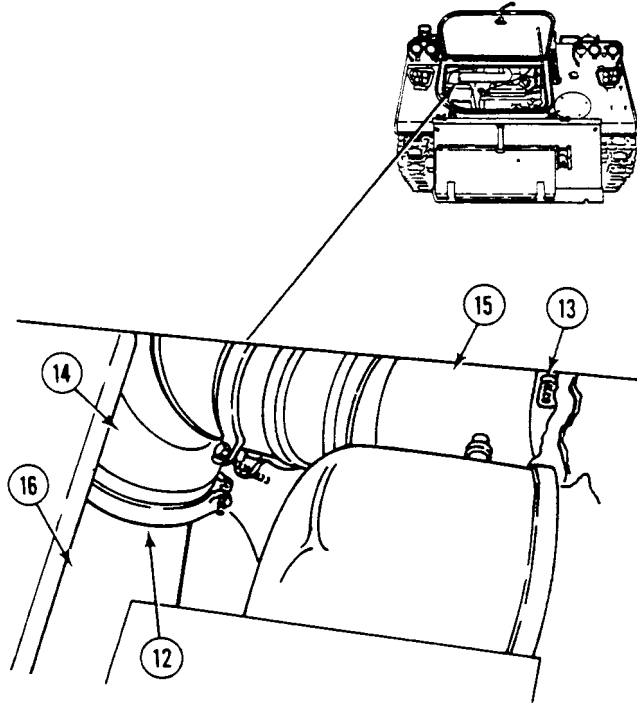

- Remove two elbows (1)(2) from turbo (3) and muffler (4) and set on sponson (5).

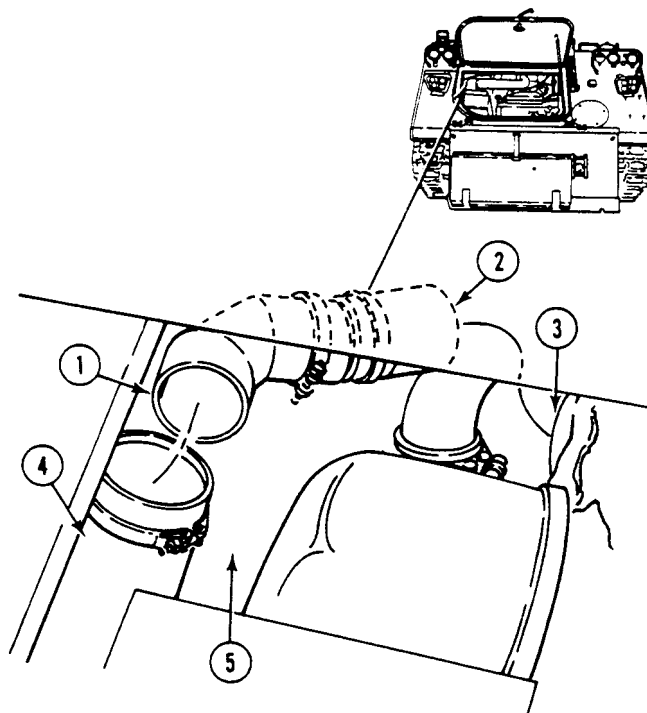

- Loosen clamp (6) on lower intake hose (7). Slide hose off elbow (8).

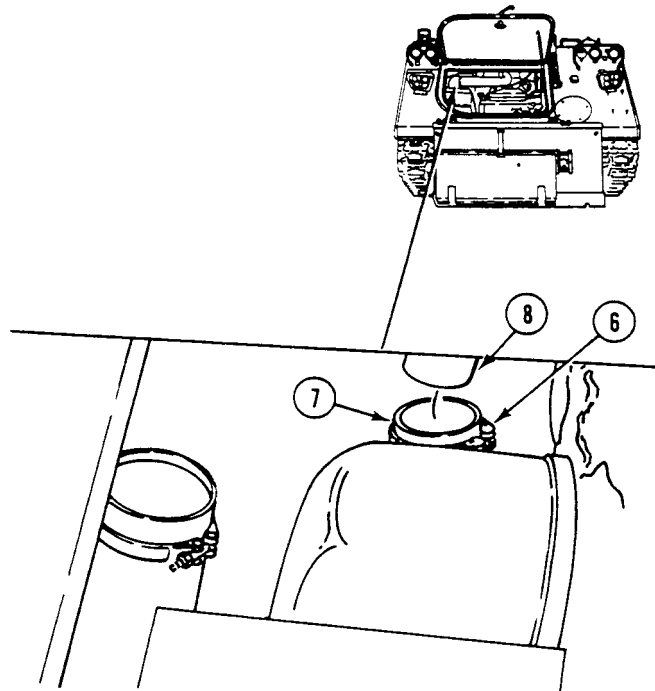

- Remove 14 screws (9) and washers (10) from power plant grill (11).

NOTE

Note location of 14 screws removed. One is the lifting eye screw and two are coarse threaded screws.

- Stow power plant front access door brace (12). Lay access door (13) back on power plant grill (11).

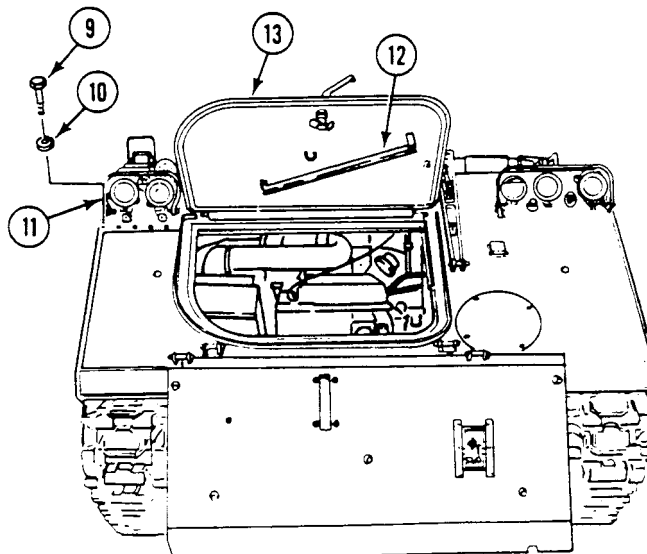

WARNING

Damaged lifting slings can fail with load. Soldiers can be killed or injured. Inspect all slings before use. Do not use damaged slings.

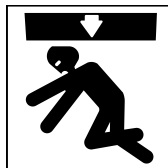
WARNING

Grill and access cover are very heavy. Use extreme caution when lifting, blocking, and lowering assembly. Allowing assembly to fall could cause death or injury.

CAUTION

Use chain and lifting device capable of lifting and holding 2000 lbs (908 kg) securely.

CAUTION

The power plant door is heavy. If necessary, use extra helpers and straps/chains to guide and control power plant door.

CAUTION

To prevent damage to power plant front access door, guide door as grill is lowered into braced position.

11. (H) Loop a 6-foot strap or chain through power plant door latch and hold door (1) back as power plant grill (2) is being raised.

12. Use lifting device to raise grill (2) to vertical position.

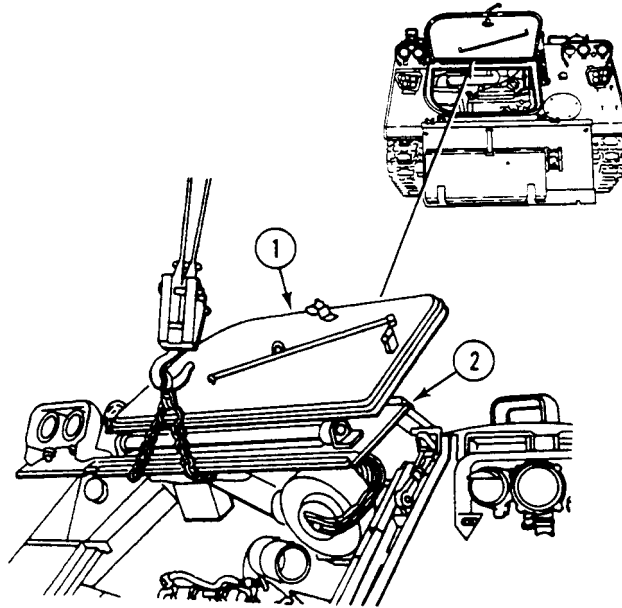

13. Remove screw (3) and locknut (4) that secure brace (5) to lug (6).

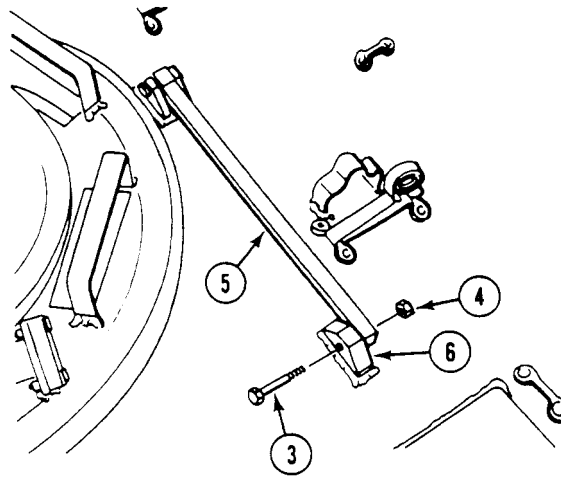

14. Raise power plant grill (2) to open stowed position.

15. Place brace (5) between two lugs (6). Secure with screw (3) and locknut (4).

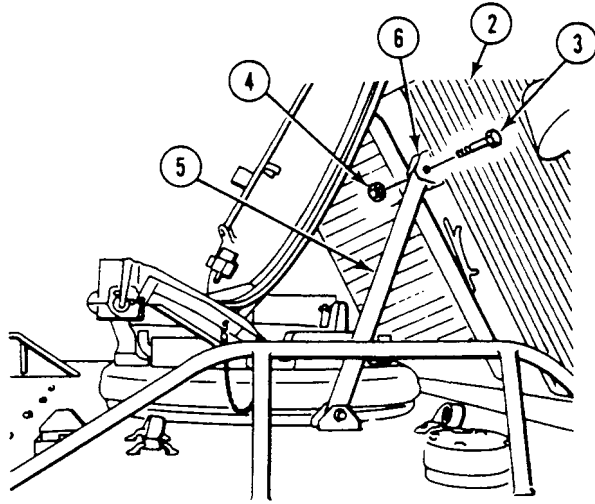

LOWER

1. Install lower intake hose (7) on elbow (8). Secure with clamp (9).

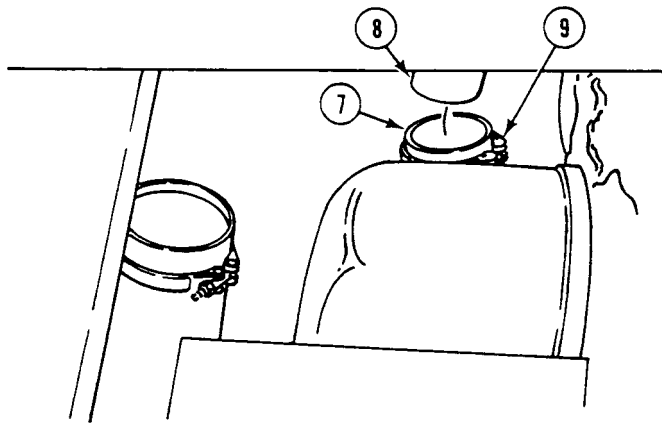

2. Install two elbows (1) and (2) on turbo (3) and muffler (4). Secure with two clamps (5).

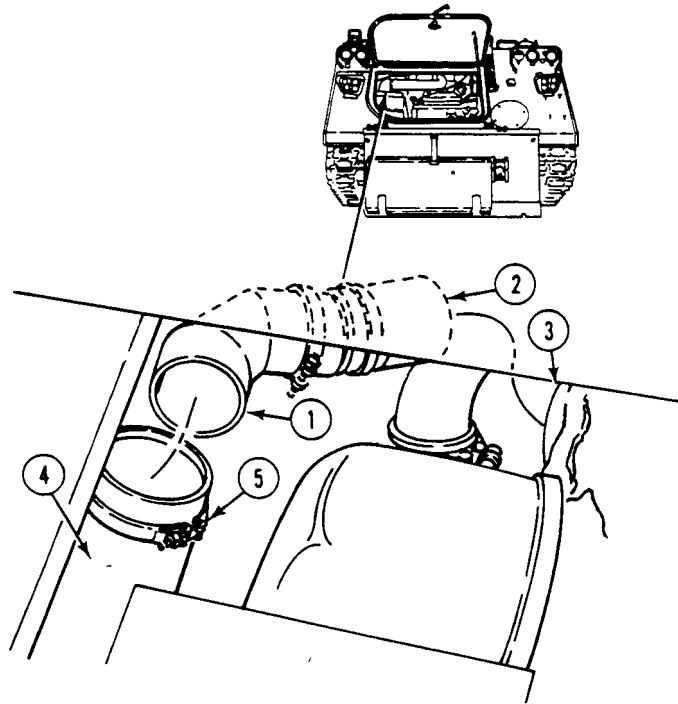

CAUTION

Be sure to use strap installed in step (11) to guide power plant access door while grill is being lowered.

NOTE

Before lowering grill, apply caulking compound to metal joints between hull and lower support of grill to assure water tightness.

3. With lifting device still attached to grill (6), remove screw (7), locknut (8), and brace (9) from two lugs (10).

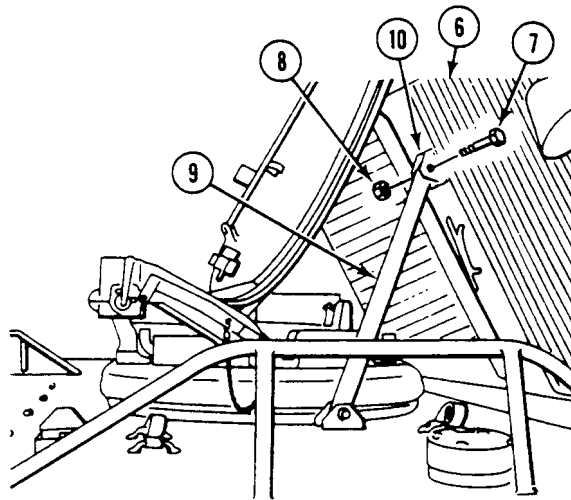

4. Stow brace (9) to lug (10) with screw (7) and locknut (8).

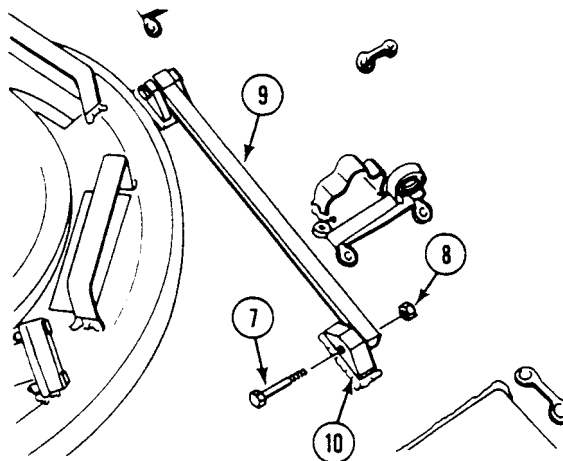

WARNING

Damaged lifting slings can fail with load. Soldiers can be killed or injured. Inspect all slings before use. Do not use damaged slings.

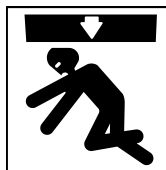
WARNING

Grill and access cover are very heavy. Use extreme caution when lifting, blocking, and lowering assembly. Allowing assembly to fall could cause death or injury.

CAUTION

Use chain and lifting device capable of lifting and holding 2000 lbs (908 kg) securely.

CAUTION

The power plant door is heavy. If necessary, use extra helpers and straps/chains to guide and control power plant door.

5. Use lifting device to lower grill (1) into closed position.

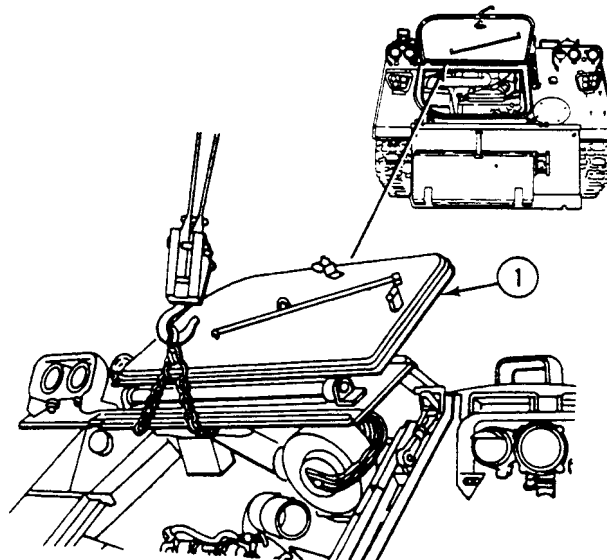

CAUTION

Of the 14 screws removed, one is the lifting eye screw and two are coarse threaded screws.
Make sure the different screws are installed in their proper places.

6. Secure grill (1) to hull (2) with 14 screws (3) and washers (4). TIGHTEN LIFTING EYE SCREW TO 175-200 LB-FT (237-271 N·m) TORQUE. TIGHTEN TWO COARSE THREADED SCREWS TO 151-166 LB-FT (205-225 N·m) TORQUE. TIGHTEN 11 SCREWS TO 100-120 LB-FT (136-163 N·m) TORQUE.
7. Secure power plant front access door (5) in open position with door brace (6).

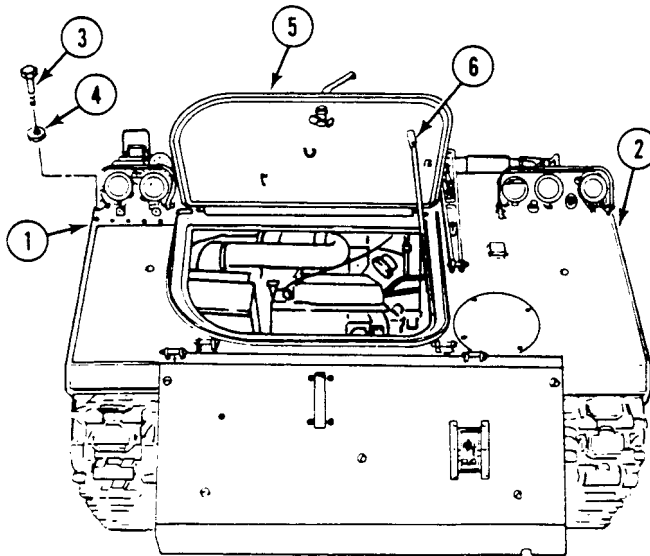

8. Connect cannon plug of headlight wiring harness (7) to hull (8).

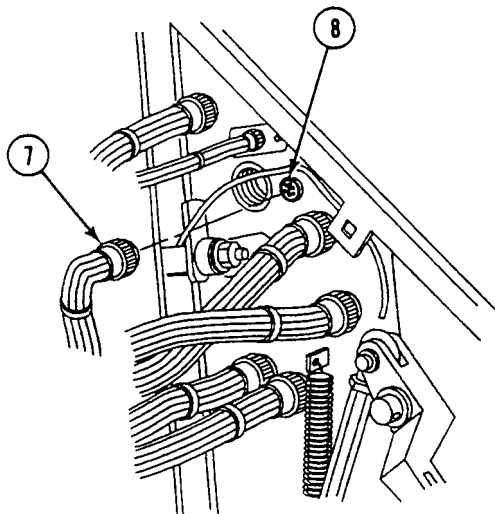

9. Connect auxiliary fluid detector (1) on auxiliary tank (2) to cable (3).

10. Install three hoses (4)(5)(6) on auxiliary tank (2). Secure with three clamps (7)(8)(9).

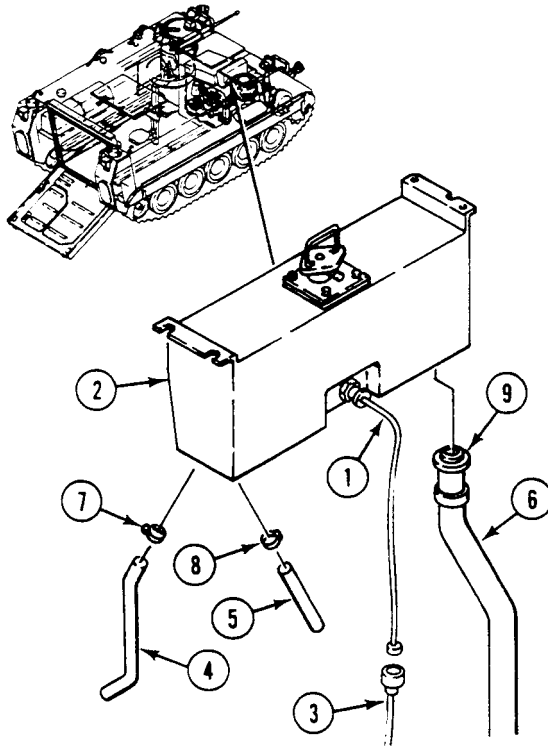

11. Install two hoses (10)(11) on two elbows (12)(13). Tighten four clamps (14)(15).

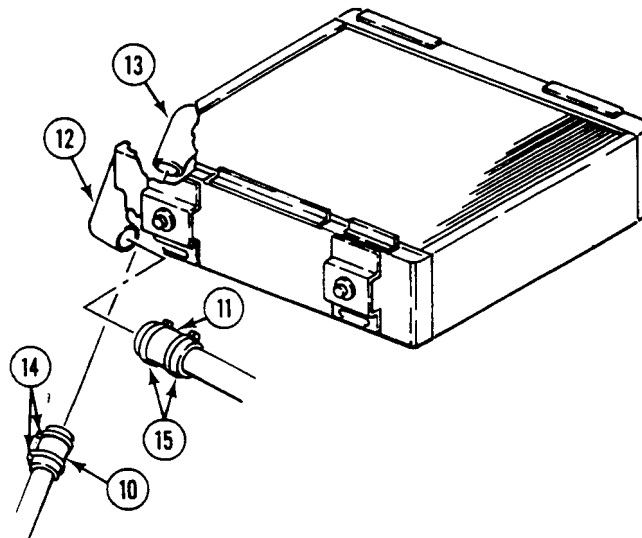

FOLLOW-THROUGH STEPS

1. If removed, install coolant heater exhaust (WP 0724 00).
2. Install muffler extension and cap (WP 0223 00).
3. Install ventilating fan drive belt (WP 0243 00).
4. Fill cooling system (WP 0227 00).
5. Install power plant upper rear access panel (WP 0439 00).
6. Install driver's power plant access panel (WP 0441 00).
7. Close power plant front access door (see your -10).
8. Raise trim vane (see your -10).
9. Install 4.2 KW generator set (M577A3 and M1068A3 ONLY) (see your -10).
10. Or Install 5.0 KW auxiliary power unit. See TM 9-6115-664-13&P.

END OF TASK

REMOVE/INSTALL POWER PLANT GRILLE

0465 00

THIS WORK PACKAGE COVERS:

Removal (page 0465 00-1).
 Installation (page 0465 00-3).

INITIAL SETUP:

Maintenance Level

Unit

References

See your -10

Tools and Special Tools

General Mechanic's Tool Kit (WP 0926 00, Item 65)

Equipment Condition

Engine stopped (see your -10)
 Carrier blocked (see your -10)
 Power plant grille raised (WP 0464 00)

Personnel Required

Unit Mechanic
 Helper

REMOVAL

WARNING

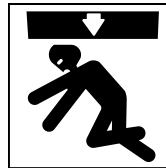

The grille assembly will swing when screws are removed. To avoid injury, do not stand in front of or behind grille assembly.

Damaged lifting slings can fail with load. Soldiers can be killed or injured. Inspect all slings before use. Do not use damaged slings.

Grill and access cover are very heavy. Use extreme caution when lifting, blocking, and lowering assembly. Allowing assembly to fall could cause death or injury.

CAUTION

To prevent damage to fan, radiator, and elbows, lower grille onto wood blocks or suitable frame that will support edge of grille.

Use chain and lifting device capable of lifting and holding 2000 lbs (908 kg) securely.

The power plant door is heavy. If necessary, use extra helpers and straps/chains to guide and control power plant door.

1. Support grille assembly with lifting device.

WARNING

The grille assembly will swing when screws are removed. To avoid injury, do not stand in front of or behind grille assembly.

Damaged lifting slings can fail with load. Soldiers can be killed or injured. Inspect all slings before use. Do not use damaged slings.

Grill and access cover are very heavy. Use extreme caution when lifting, blocking, and lowering assembly. Allowing assembly to fall could cause death or injury.

CAUTION

To prevent damage to fan, radiator, and elbows, lower grille onto wood blocks or suitable frame that will support edge of grille.

Use chain and lifting device capable of lifting and holding 2000 lbs (908 kg) securely.

The power plant door is heavy. If necessary, use extra helpers and straps/chains to guide and control power plant door.

2. Remove two screws (2) and locknuts (3) from two lugs on grille (1). Discard locknuts.

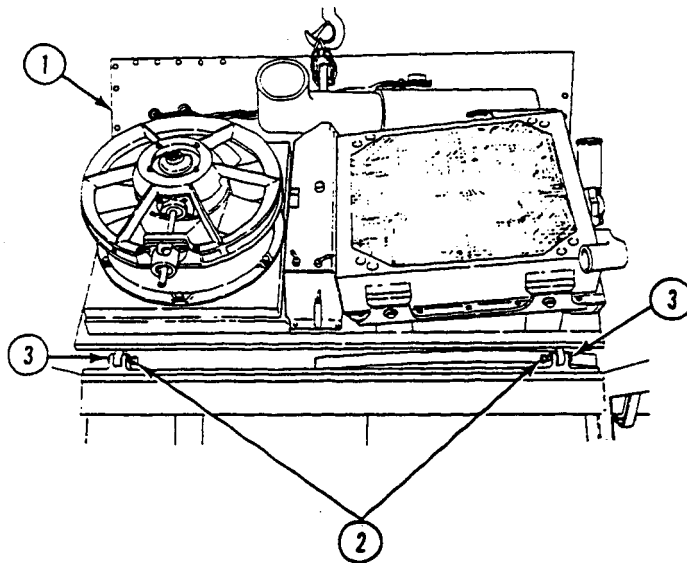

3. Lift and remove grille (1) from carrier. Lower grille onto wood blocks or suitable frame. have helper assist.

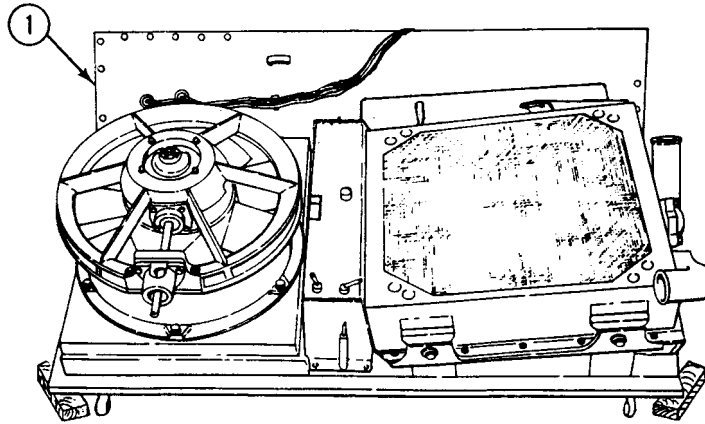

INSTALLATION

1. Lift grille (1) from wood blocks/frame and lower into place on carrier. Have helper assist.

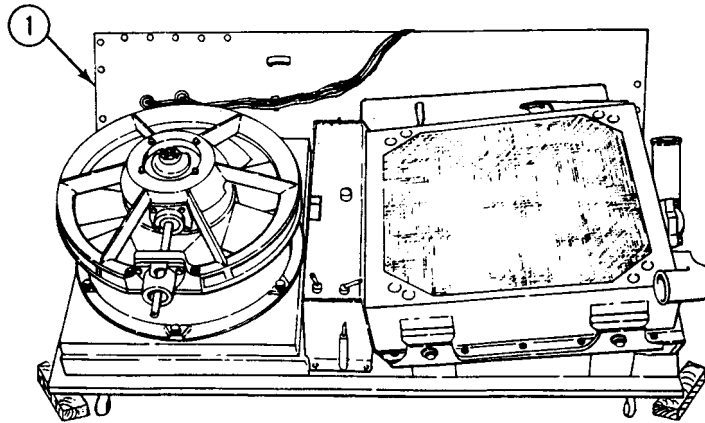

- Secure grille (1) to carrier with two screws (2) and new locknuts (3).

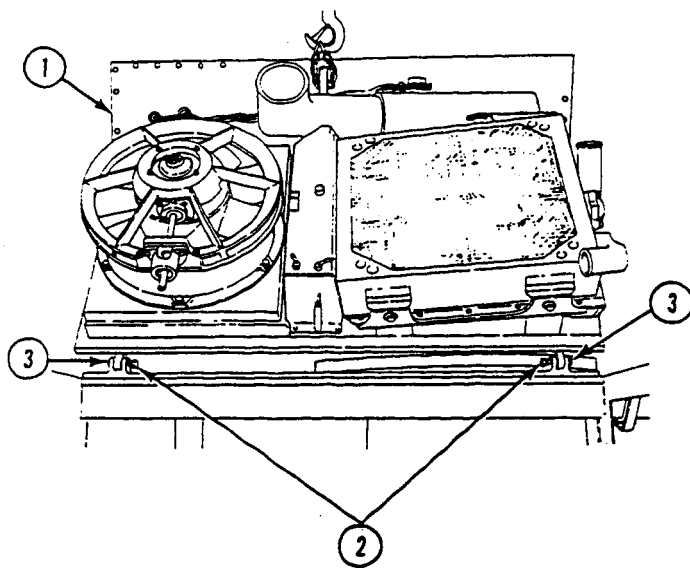
**FOLLOW-THROUGH STEPS**

- Lower power plant grille (WP 0464 00).

END OF TASK

REPLACE COMBAT FILLER COVER AND LOCK

0466 00

THIS WORK PACKAGE COVERS:

Removal (page 0466 00-1).
 Installation (page 0466 00-2).

INITIAL SETUP:

Maintenance Level

Unit

References

See your -10

Tools and Special Tools

General Mechanic's Tool Kit (WP 0926 00, Item 65)

Equipment Condition

Engine stopped (see your -10)

Power plant rear access panel removed (see your -10)

Materials/Parts

Spring pin (3)

Personnel Required

Unit Mechanic

REMOVAL

1. Loosen wing nut (1). Remove thumbscrew (2), washer (3), and spacer (4) from power plant grill.
2. Remove spring pin (5), washer (6), spring (7), and pin (8) from power plant grill. Discard spring pin.
3. Remove two spring pins (9) and cover (10) from power plant grill. Discard spring pins.

NOTE

Removal Step 4 and Installation Step 1 are for M577A3 and M1068A3 only.

4. Remove nut (11), washer (12), two spring pins (13), rod end (14), and cover (15) for M577A3 and M1068A3 only.

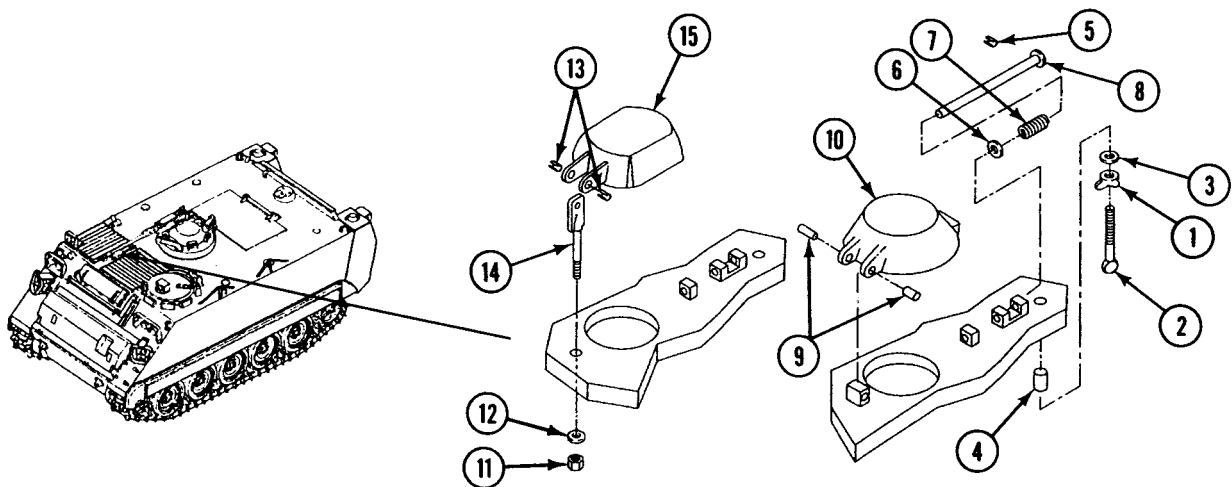

M577A3 / M1068A3

INSTALLATION

1. Install cover (15), rod end (14), two new pin springs (13), washer (12) and nut (11) for M577A3 and M1068A3 only.
2. Secure cover (10) to power plant grill with two new spring pins (9) for all vehicles except M577A3.
3. Install pin (8) in power plant grill. Secure with spring (7), washer (6), and new spring pin (5).
4. Install wing nut (1), washer (3), and spacer (4) on thumbscrew (2).
5. Install thumbscrew (2) in power plant grill.

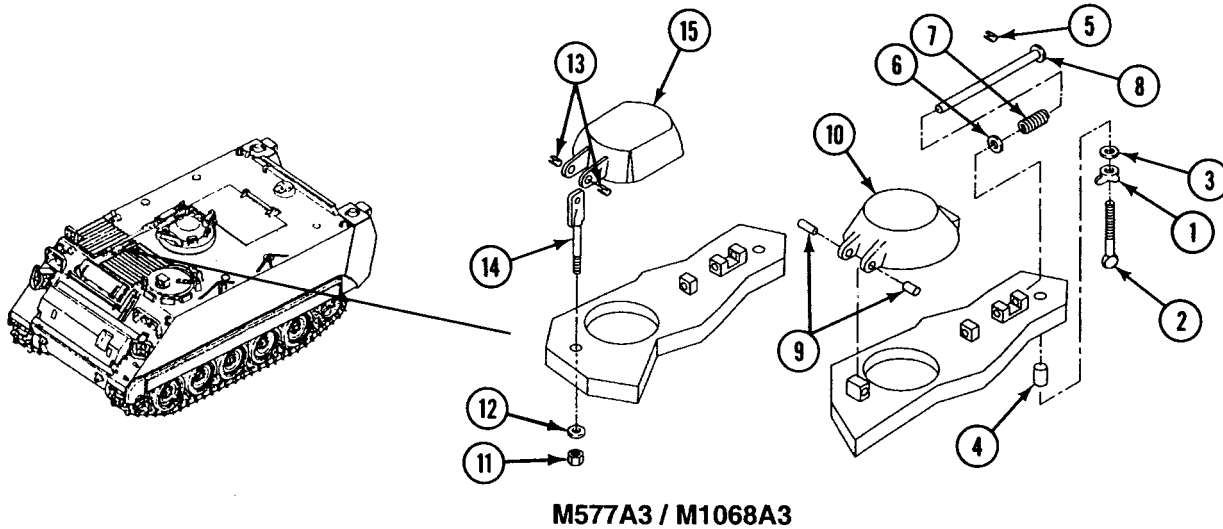
**FOLLOW-THROUGH STEPS**

1. Install power plant rear access panel (see your -10).

END OF TASK

REPLACE POWER PLANT GRILL SUPPORT ARM

0467 00

THIS WORK PACKAGE COVERS:

Removal (page 0467 00-1).
 Installation (page 0467 00-2).

INITIAL SETUP:

Maintenance Level

Unit

References

See your -10

Tools and Special Tools

General Mechanic's Tool Kit (WP 0926 00, Item 65)

Equipment Condition

Engine stopped (see your -10)

Materials/Parts

Locknut (2)

Carrier blocked (see your -10)

Personnel Required

Unit Mechanic

REMOVAL

1. Remove two locknuts (1), screws (2), and grill support arm (3) from two hull top plate mounts. Discard locknuts.

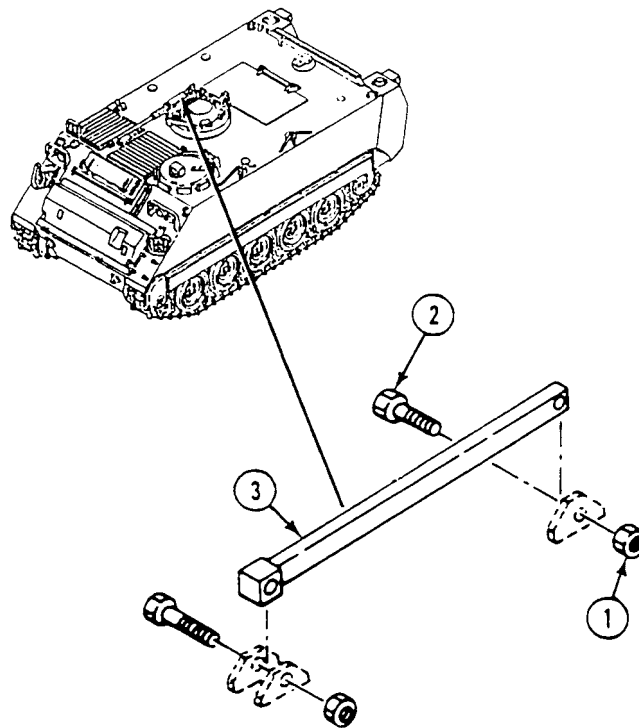

INSTALLATION

1. Place grill support arm (3) in hull top plate mounts with plastic-coated end facing forward.

NOTE

Forward screw must be installed from right side of carrier, as shown.

2. Align grill support arm (3) with mounts. Secure with two screws (2) and new locknuts (1).

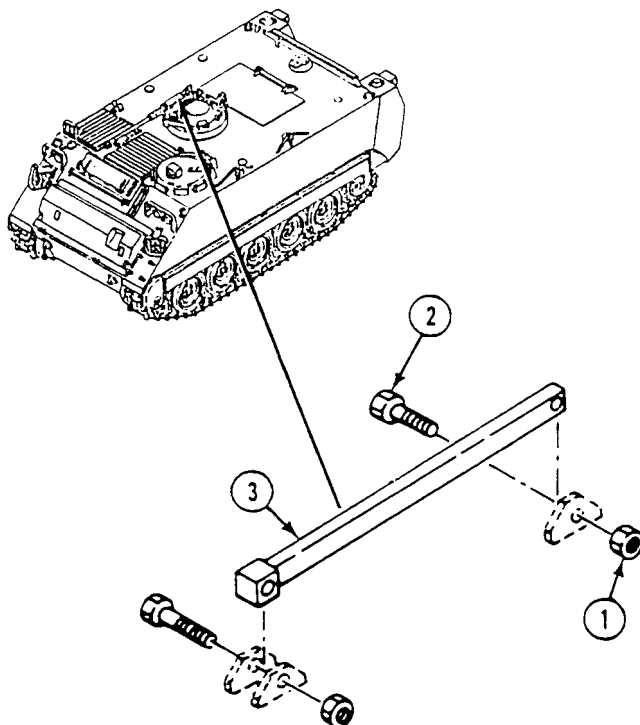

END OF TASK

REPLACE POWER PLANT GRILL SCREEN

0468 00**THIS WORK PACKAGE COVERS:**

Removal (page 0468 00-1).
Installation (page 0468 00-1).

INITIAL SETUP:

Maintenance Level
Unit

References
See your -10

Tools and Special Tools
General Mechanic's Tool Kit (WP 0926 00, Item 65)

Equipment Condition

Personnel Required
Unit Mechanic

Engine stopped (see your -10)
Carrier blocked (see your -10)

REMOVAL**NOTE**

Latest configuration screen is attached to grill with adhesive.

1. Remove two screws (1), washers (2), and screen (3) from power plant grill (4).

INSTALLATION

1. Install screen (3) on grill (4). Secure screen to grill with two washers (2) and screws (1).

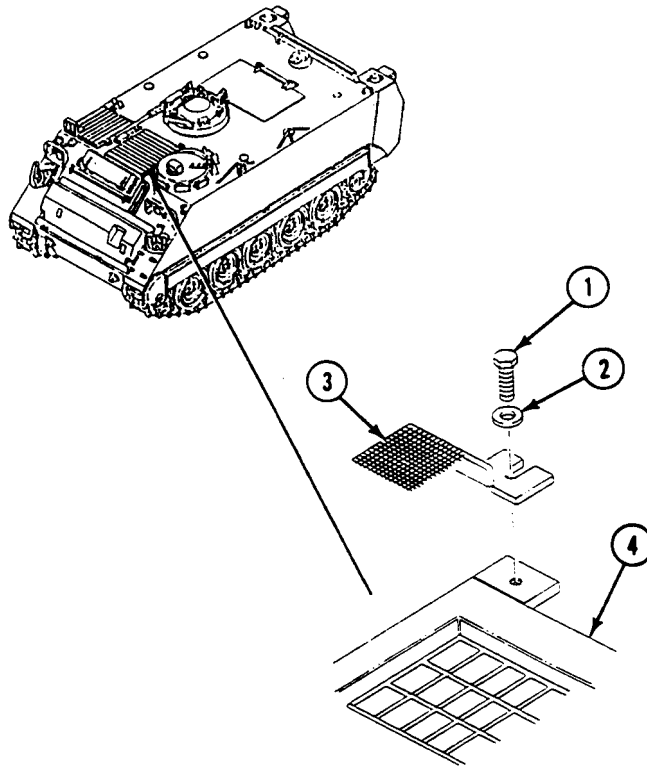
**END OF TASK**

REPLACE RADIATOR ACCESS DOOR

0469 00

THIS WORK PACKAGE COVERS:

Removal (page 0469 00-1).
 Installation (page 0469 00-1).

INITIAL SETUP:

Maintenance Level

Unit

References

See your -10

Tools and Special Tools

General Mechanic's Tool Kit (WP 0926 00, Item 65)

Equipment Condition

Engine stopped (see your -10)
 Carrier blocked (see your -10)
 Driver's power plant access panel
 removed (see your -10)

Personnel Required

Unit Mechanic

REMOVAL

1. Loosen two bolts (1) and clamps (2). Remove radiator access panel (3) from power plant compartment bulkhead.
2. Release two fasteners (4) on access door (5) and remove access door.

INSTALLATION

1. Install radiator access door (5) and secure two fasteners (4).

2. Install radiator access panel (3) on power plant compartment bulkhead. Secure with two clamps (2) and bolts (1).

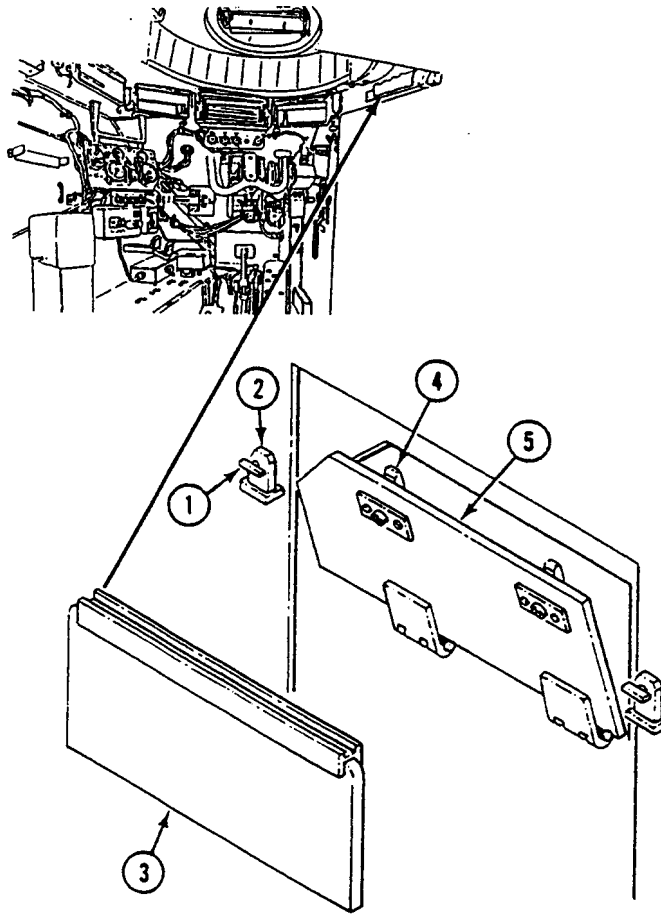
**FOLLOW-THROUGH STEPS**

1. Install driver's power plant access panel (see your -10).

END OF TASK

REPLACE POWER PLANT DOOR (M113A3 ONLY)

0470 00

THIS WORK PACKAGE COVERS:

Removal (page 0470 00-1)
 Installation (page 0470 00-3).

INITIAL SETUP:

Maintenance Level
 Unit

References
 See your -10

Tools and Special Tools
 General Mechanic's Tool Kit (WP 0926 00, Item 65)
 Torque Wrench (WP 0926 00, Item 83)
 Sling (Endless) (WP 0926 00, Item 47)
 Suitable Lifting Device

Equipment Condition
 Engine stopped (see your -10)
 Carrier blocked (see your -10)
 Trim vane lowered and disconnected (see your -10)
 Power plant door open (see your -10)

Personnel Required
 Unit Mechanic
 Helper (H)

REMOVAL

WARNING



Power plant door is heavy. It can fall and injure you. Do not remove housing before relieving spring tension by lifting and holding with lifting device.

Damaged lifting slings can fail with load. Soldiers can be killed or injured. Inspect all slings before use. Do not use damaged slings.

1. Connect a suitable lifting device and sling around power plant door. Raise power plant door until tension is released on tension springs.

REPLACE POWER PLANT DOOR (M113A3 ONLY) — Continued**0470 00**

2. Remove two screws (1) and washers (2) from housing (3) and bracket (4). Remove housing.
3. Remove nine springs (5) and place on something clean.
4. Remove four screws (6), washers (7), two brackets (4), shims (8), and power plant door (9) from hull.
5. Remove two spacers (10) from ends of power plant door (9).

NOTE

Spacers in Step 6 (up to three on each side) are used as required.

6. Remove spacers (11) from ends of power plant door (9).
7. Remove shield (12) from power plant door (9).

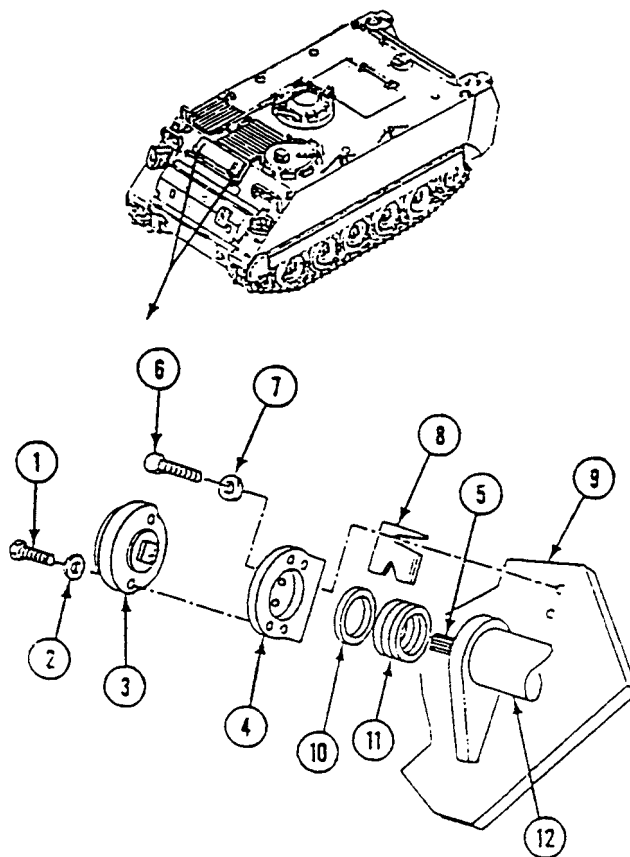

INSTALLATION

1. Install shield (1) on power plant door (2).
2. Install two spacers (3) on ends of power plant door (2).

NOTE

Install spacers in Step 3 (up to three on each side) as required to allow power plant door to swing freely.

3. Install spacers (4) on ends of power plant door (2).
4. Install bracket (5) (with square hole) on left end of power plant door (2), over springs (6).
5. Install bracket (5) on right end of power plant door (2).

WARNING



Power plant door is heavy. It can fall and injure you. Do not remove housing before relieving spring tension by lifting and holding with lifting device.

Damaged lifting slings can fail with load. Soldiers can be killed or injured. Inspect all slings before use. Do not use damaged slings.

6. With suitable lifting device place power plant door (2) in open position, so brackets (5) can be secured to hull with four screws (7) and washers (8). Do not tighten screws.
7. Lower power plant door and check for a secure and even fit. If power plant door does not clear top of opening, shims (9) must be added until an even fit around the hull is obtained. Place shims (9) under brackets (5). Tighten screws (7) snug after each shim is installed until power plant door clears top of opening.
8. **TIGHTEN FOUR SCREWS (7) TO 18-20 LB-FT (24-27 N·m) TORQUE.**

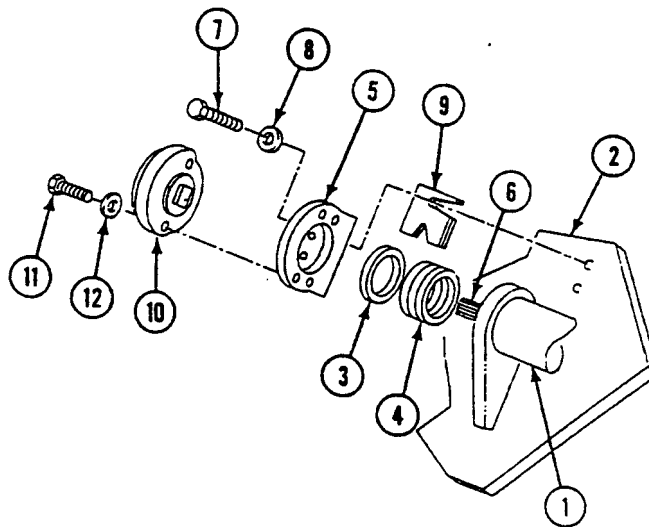

NOTE

If housing is aligned with wrong holes there could be too much tension when the power plant door armor is not installed, or too little tension when the power plant door armor is installed.

9. Install nine springs (6) in square opening in left bracket (5). Raise door (2) until housing (10) can be installed. Align housing with holes on bracket (5) by moving the door back and forth.
10. Secure housing (10) with two screws (11) and washers (12).
11. Remove lifting device from power plant door.

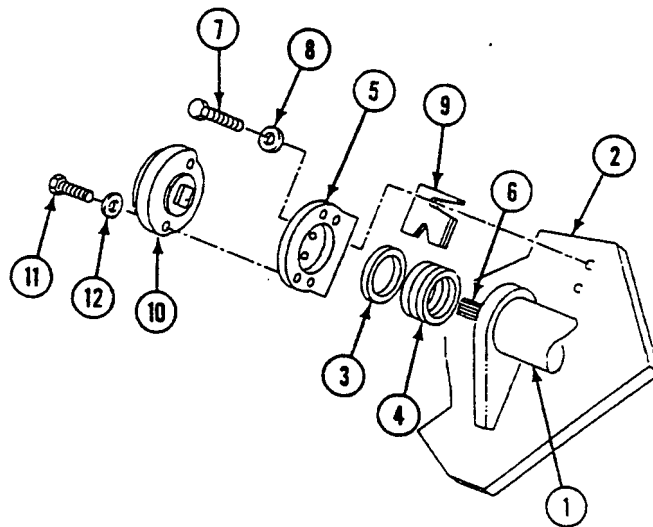
**FOLLOW-THROUGH STEPS**

1. Close and lock power plant door (see your -10).
2. Connect and raise trim vane (see your -10).

END OF TASK

REPLACE POWER PLANT DOOR (ALL EXCEPT M113A3)

0471 00

THIS WORK PACKAGE COVERS:

Removal page 0471 00-1
 Installation page 0471 00-2

INITIAL SETUP:

Maintenance Level

Unit

Personnel Required

Unit Mechanic
 Helper (H)

Tools and Special Tools

General Mechanic's Tool Kit (WP 0926 00, Item 65)
 Socket Wrench Set (WP 0926 00, Item 72)
 Torque Wrench (WP 0926 00, Item 81)
 Sling (WP 0926 00, Item 47)
 Suitable Lifting Device

References

See your -10

Equipment Condition

Engine stopped (see your -10)
 Carrier blocked (see your -10)
 Trim vane lowered and disconnected (see your -10)
 Power plant door open (see your -10)

REMOVAL

WARNING

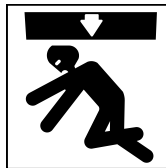

Power plant door is heavy. It can fall and injure you. Do not remove housing before relieving spring tension by lifting and holding with lifting device.

Damaged lifting slings can fail with load. soldiers can be killed or injured. Inspect all slings before use. Do not use damaged slings.

1. Connect a suitable lifting device and sling around power plant door. Hold door straight up until tension is gone.

2. Remove four screws (1), washers (2), two brackets (3)(4), plates (5), and power plant door (6) from hull.
3. Remove two spacers (7) from ends of power plant door (6).

INSTALLATION

WARNING



Power plant door is heavy. It can fall and injure you. Do not remove housing before relieving spring tension by lifting and holding with lifting device.

Damaged lifting slings can fail with load. Soldiers can be killed or injured. Inspect all slings before use. Do not use damaged slings.

1. Install two spacers (7) on ends of power plant door (6).
2. Install bracket (3) on right end of power plant door (6).
3. Install bracket (4) on left end of power plant door (6), with door in open position, so brackets (3)(4) can be secured to hull. Install two brackets, four washers (2), and screws (1) on hull. Do not tighten screws.

NOTE

Do Step 4 if power plant door does not clear top of opening.

4. Place plates (5) under brackets (3)(4). After each plate is installed, tighten screws (1) until power plant door (6) clears top of opening.
5. TIGHTEN FOUR SCREWS (1) TO 216-240 LB-IN (24-27 N·m) TORQUE.
6. Remove lifting device and sling from power plant door.

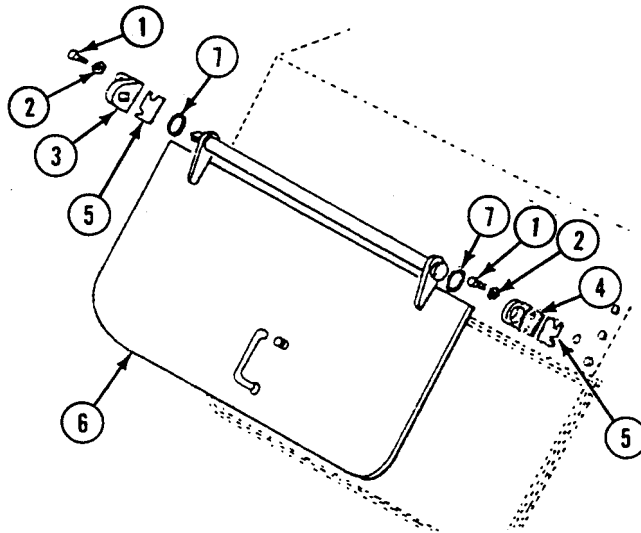

FOLLOW-THROUGH STEPS

1. Close and lock power plant door (see your -10).
2. Connect and raise trim vane (see your -10).

END OF TASK

REPAIR POWER PLANT DOOR

0472 00

THIS WORK PACKAGE COVERS:

- Disassemble (page 0472 00-1)
- Assemble (page 0472 00-2).
- Adjust (page 0472 00-2).

INITIAL SETUP:

Maintenance Level

Unit

Locknut

Packing

Seal

Tools and Special Tools

General Mechanic's Tool Kit (WP 0926 00, Item 65)

Personnel Required

Unit Mechanic

Materials/Parts

Cotter pin

Equipment Condition

Power plant door removed from carrier
(WP 0470 00) or (WP 0471 00)

DISASSEMBLY

1. Remove vehicular leaf pins (1) and shield (2) from door (3).
2. Remove locknut (4), screw (5), and brace (6) from door (3). Discard locknut.
3. Remove cotter pin (7), nut (8), catch (9), and washer (10) from handle (11). Discard cotter pin.
4. Remove handle (11), washer (12), packing (13), and key (14) from door (3). Discard packing.
5. Remove screw (15) and nut (16) from door (3).

NOTE

Do Removal Step 6 and Installation Step 1 only if door seal is damaged.

6. Bend back door seal support and remove seal (17) from door (3). Discard seal.

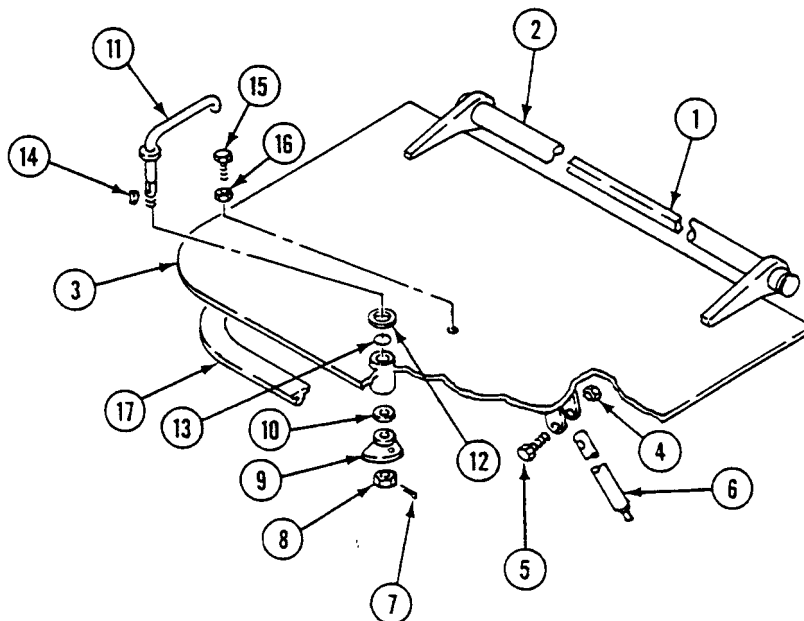

ASSEMBLY

1. If removed, install new seal (1) on door (2). Bend seal support into place to hold seal.
2. Install nut (3) and screw (4) on door (2).
3. Install washer (5) and new packing (6) on handle (7).
4. Install key (8) on handle (7). Insert handle and key in door (2). Make sure key (8) and keyway in door are aligned.
5. Install washer (9), catch (10), nut (11), and new cotter pin (12) on handle (7).
6. Install brace (13) on door (2). Secure with screw (14) and new locknut (15).
7. Install shield (16) and vehicular leaf pins (17) on door (2).

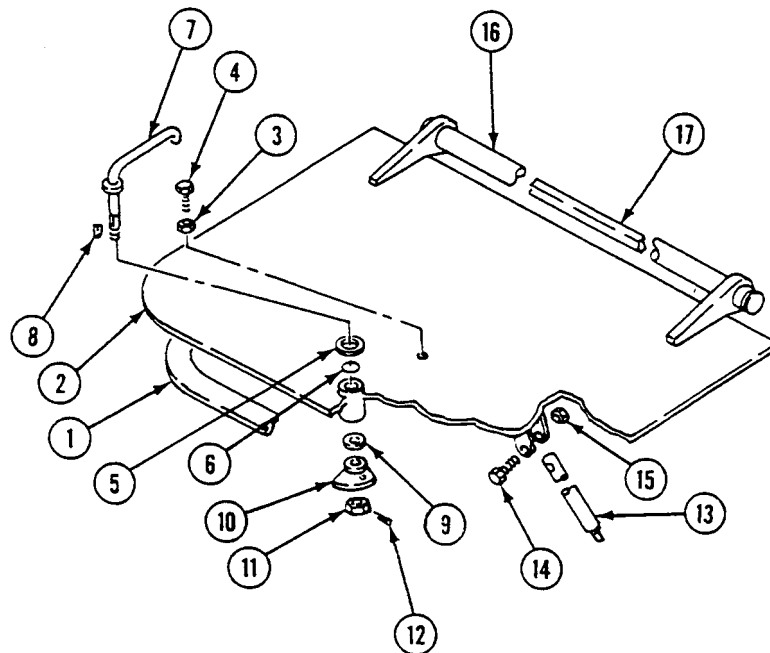
**ADJUSTMENT**

1. Adjust screw (4) until handle (7) rubs on head of screw. This adds slight detent action when opening or closing door (2).

NOTE

After door is installed on carrier, it may be necessary to add or remove washers until door locks securely on hull.

FOLLOW-THROUGH STEPS

1. Install power plant door on carrier (WP 0470 00) or (WP 0471 00) .

END OF TASK

REPLACE POWER PLANT DOOR COMBAT LOCK

0473 00

THIS WORK PACKAGE COVERS:

Removal (page 0473 00-1).
 Installation (page 0473 00-3).

INITIAL SETUP:

Maintenance Level

Unit

References

See your -10

Tools and Special Tools

General Mechanic's Tool Kit (WP 0926 00, Item 65)

Equipment Condition

Engine stopped (see your -10)
 Carrier blocked (see your -10)
 Trim vane lowered and disconnected (see your -10)
 Power plant door open (see your -10)
 Battery ground strap disconnected (WP 0337 00),
 (WP 0338 00), or (WP 0339 00)

Materials/Parts

Drive pin

Personnel Required

Unit Mechanic
 Helper (H)

REMOVAL

NOTE

Tag or mark each harness to make sure each is installed in the right receptacle after service.

1. Disconnect four wiring harnesses (1) from bulkhead inside driver's compartment.

REPLACE POWER PLANT DOOR COMBAT LOCK — Continued

0473 00

2. (H) Hold hand under bolt (2) from outside carrier through power plant access door opening.
3. Drive out pin (3). Remove handle (4) and spring (5) from bolt (2). Discard drive pin.
4. (H) Remove bolt from power plant compartment.

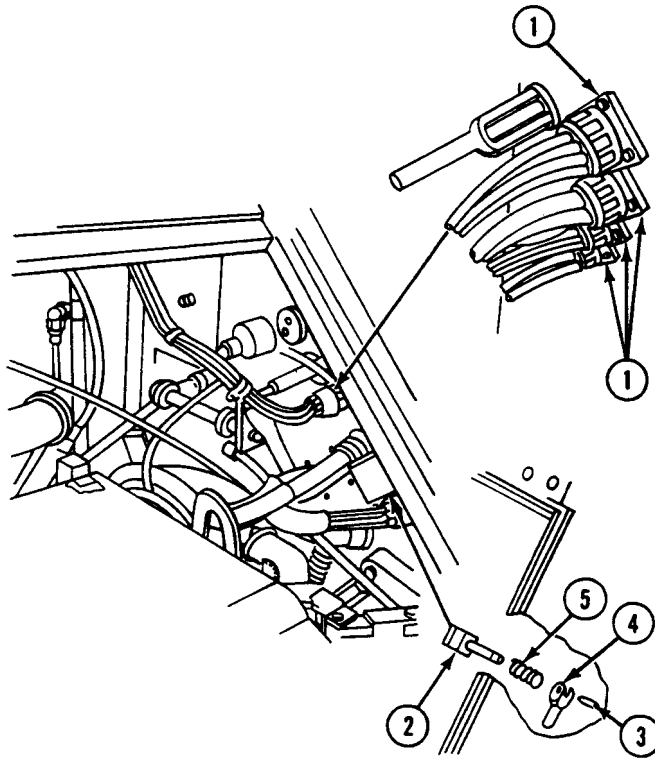

INSTALLATION

1. (H) Install bolt (1) in place from outside carrier through access to power plant compartment.
2. From inside driver's compartment, install spring (2) and handle (3) on bolt (1). Secure with new drive pin (4).
3. Connect four wiring harnesses (5) to bulkhead in driver's compartment.

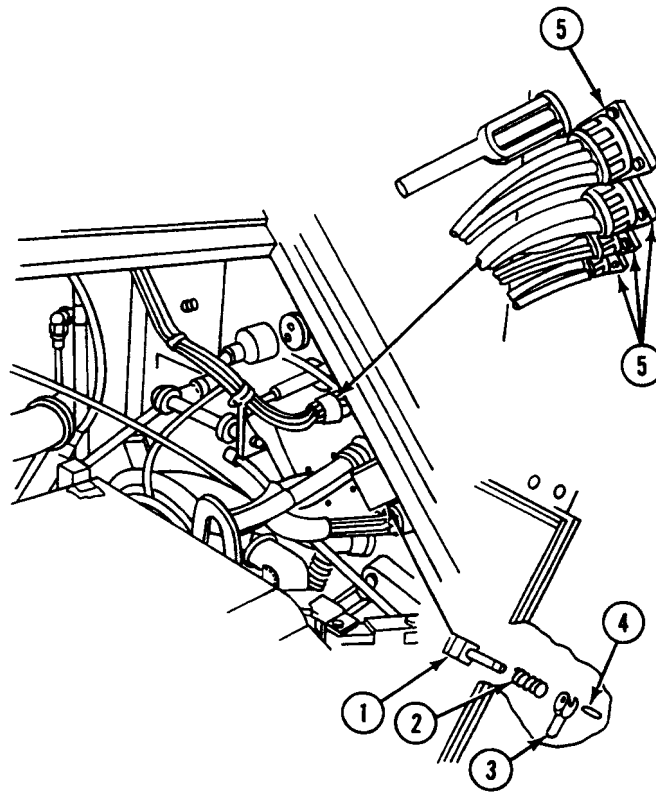
**FOLLOW-THROUGH STEPS**

1. Connect battery ground strap (WP 0337 00), (WP 0338 00), or (WP 0339 00).
2. Close power plant door (see your -10).
3. Connect and raise trim vane (see your -10).

END OF TASK

REPLACE CARGO HATCH HOLD-OPEN HOOK AND BUMPERS (M113A3 AND M1059A3 ONLY)

0474 00

THIS WORK PACKAGE COVERS:

Removal (page 0474 00-1).
 Installation (page 0474 00-3).

INITIAL SETUP:

Maintenance Level

Unit

Personnel Required

Unit Mechanic

Tools and Special Tools

General Mechanic's Tool Kit (WP 0926 00, Item 65)

References

See your -10

Materials/Parts

Locknut (2)
 Locknut (2)
 Locknut

Equipment Condition

Engine stopped (see your -10)
 Carrier blocked (see your -10)

REPLACE CARGO HATCH HOLD-OPEN HOOK AND BUMPERS (M113A3 AND M1059A3 ONLY) — Continued

0474 00

REMOVAL

1. Open both ends of hook (1). Remove hook from chain (2) and hull bracket (3).
2. Remove tube (4) from chain (2).
3. Open both ends of hook (5). Remove hook from chain (2) and safety pin (6).
4. Remove two screws (7), four washers (8), two locknuts (9), and block (10) from hull bracket (3). Discard locknuts.
5. Remove two locknuts (11), washers (12), bumpers (13), and washer(s) (14) from hull brackets. Discard locknuts.
6. Remove locknut (15), screw (16), two washers (17), spring (18), two spacers (19), and hook (20) from hull brackets. Discard locknut.

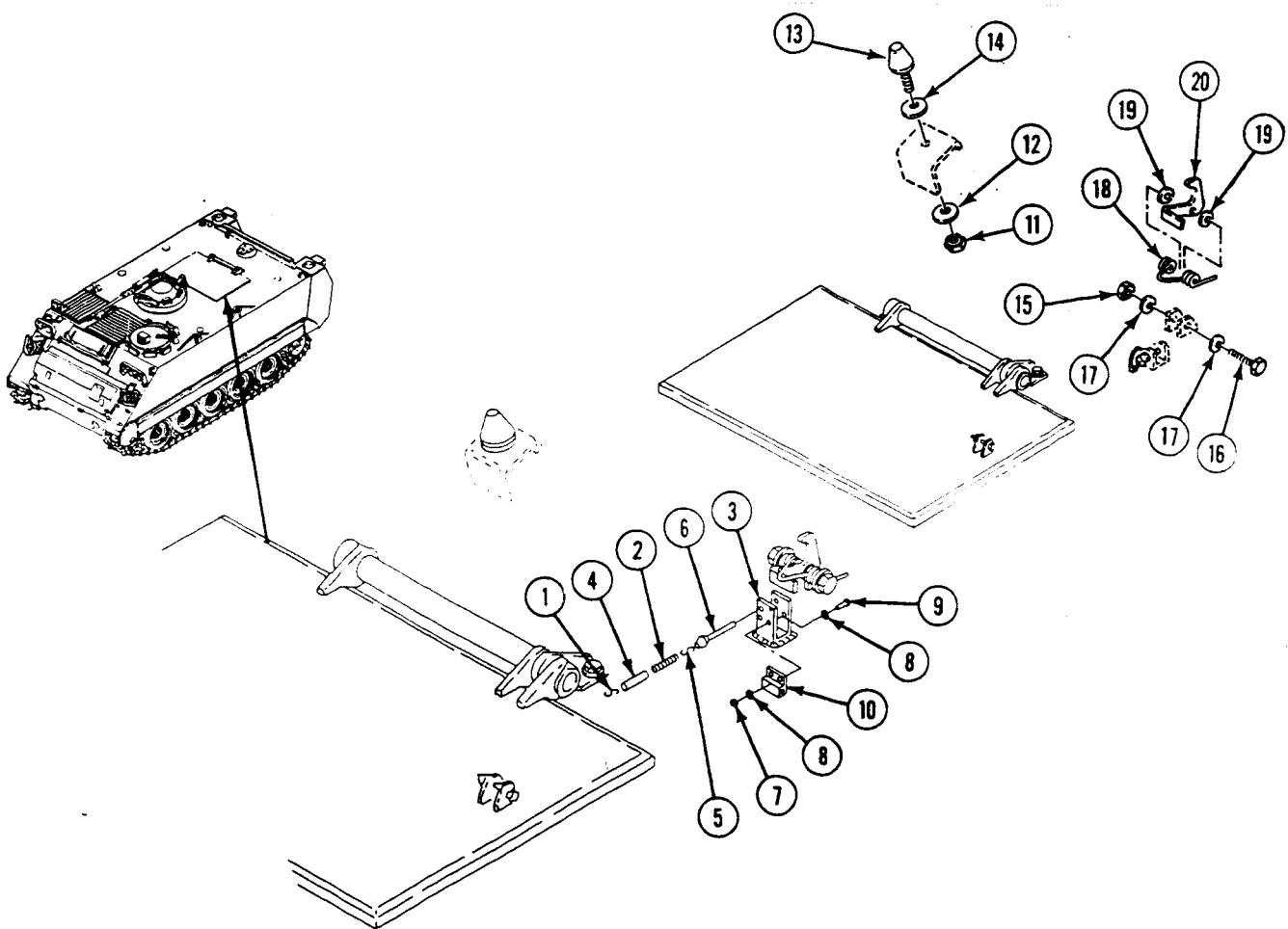

REPLACE CARGO HATCH HOLD-OPEN HOOK AND BUMPERS (M113A3 AND M1059A3 ONLY) — Continued

0474 00

INSTALLATION

1. Align hook (1), two spacers (2), spring (3), and two washers (4) with hull bracket. Secure with screw (5) and new locknut (6).

NOTE

Install washer(s), as needed, to compress left bumper 3/16 to 5/16 inch (5-8 mm) and right bumper 1/16 to 1/4 inch (2-6 mm) when hold-open hook is engaged.

2. Install washer(s) (7) and two bumpers (8) in hull brackets. Secure with two washers (9) and new locknuts (10).
3. Place block (11) on hull bracket (12). Secure with two screws (13), four washers (14), and two new locknuts (15).
4. Install hook (16) in safety pin (17) and chain (18). Squeeze both ends of hook to secure.
5. Install tube (19) on chain (18).
6. Install hook (20) on chain (18) and hull bracket. Squeeze both ends of hook to secure.

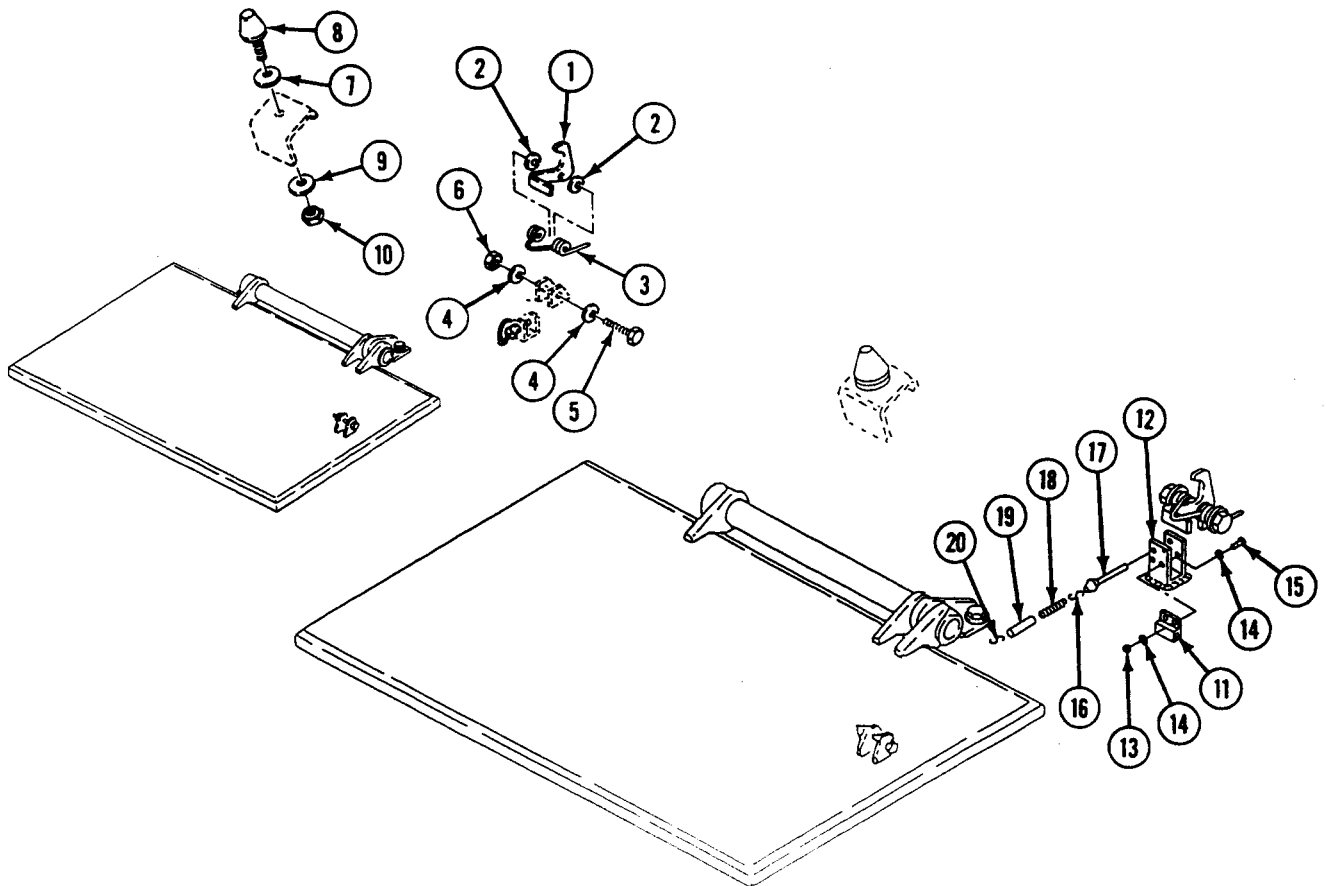

FOLLOW-THROUGH STEPS

1. Open cargo hatch cover and engage hook to check that hook and bumper are installed correctly.

END OF TASK

REPLACE CARGO HATCH INTERIOR LATCH (M113A3 AND M1059A3 ONLY)

0475 00 ■

THIS WORK PACKAGE COVERS:

- Removal (page 0475 00-1).
- Installation (page 0475 00-3).
- Adjustment (page 0475 00-5).

INITIAL SETUP:

Maintenance Level

Unit

Personnel Required

Unit Mechanic

Tools and Special Tools

- General Mechanic's Tool Kit (WP 0926 00, Item 65)
- Torque Wrench (WP 0926 00, Item 85)

References

See your -10

Materials/Parts

- Cotter pin (2)
- Lockwasher (4)

Equipment Condition

- Engine stopped (see your -10)
 - Carrier blocked (see your -10)
-

REMOVAL

NOTE

Do Step 1 and Step 2 for M113A3 (late model) only. ■

1. Remove two cotter pins (1), headed pins (2), and clevises (3) from two latches (4). Discard cotter pins.
2. Remove two clevises (3) from chain (5). Remove tube (6) from chain.

NOTE

Do Step 3 and Step 4 for M113A3 (early model) and M1059A3 only. ■

3. Spread two rings (7) and remove from strikers (8).

REPLACE CARGO HATCH INTERIOR LATCH (M113A3 AND M1059A3 ONLY) — Continued

0475 00

4. Remove two rings (7) from chain (5). Remove tube (6) from chain.
5. Remove four nuts (9) from two latches (4). Remove two latches and springs (10) from two mount brackets (11).
6. Remove eight screws (12), washers (13), two brackets (11), and washers (14) from cargo hatch cover (15).
7. Remove four screws (16), lockwashers (17), and two strikers (8) from hull. Discard lockwashers.

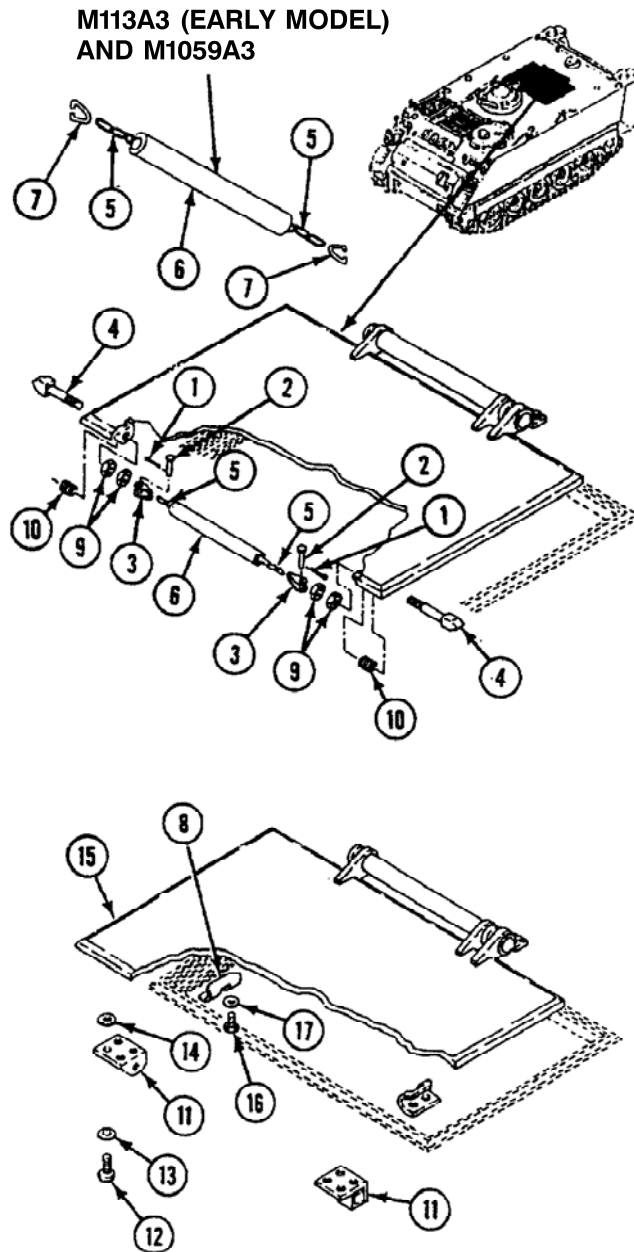

**REPLACE CARGO HATCH INTERIOR LATCH (M113A3 AND
M1059A3 ONLY) — Continued**

0475 00 ■

INSTALLATION

1. Place two strikers (1) on hull. Secure with four new lockwashers (2) and screws (3).
2. Place washers (4) and two mount brackets (5) on cargo hatch cover (6). Secure with eight washers (7) and screws (8).
Do not tighten screws.

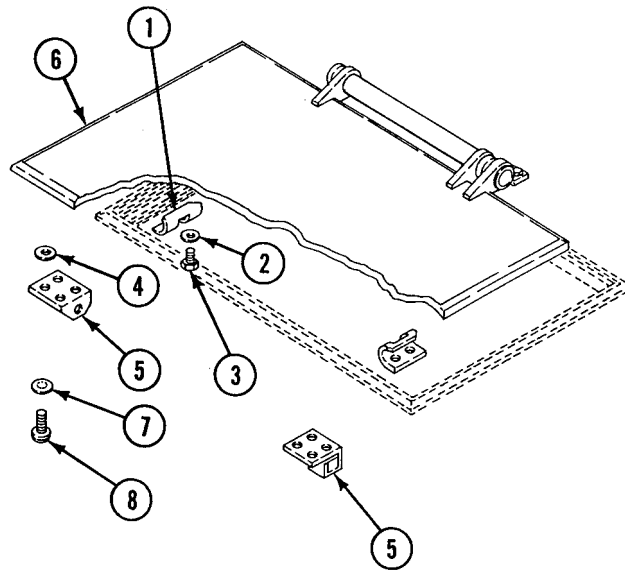

REPLACE CARGO HATCH INTERIOR LATCH (M113A3 AND M1059A3 ONLY) — Continued

0475 00

3. Install two latches (9) and springs (10) in brackets (5). Secure with four nuts (11).
4. Install tube (12) on chain (13).

NOTE

Do Step 5 for M113A3 (late model) only.

5. Install two clevises (14) on chain (13). Secure clevises to two latches (9) with headed pins (15) and new cotter pins (16).

NOTE

Do Step 6 for M1059A3 and M113A3 (early model) only.

6. Install two rings (17) on chain (13). Squeeze rings on two strikers (1) to secure.

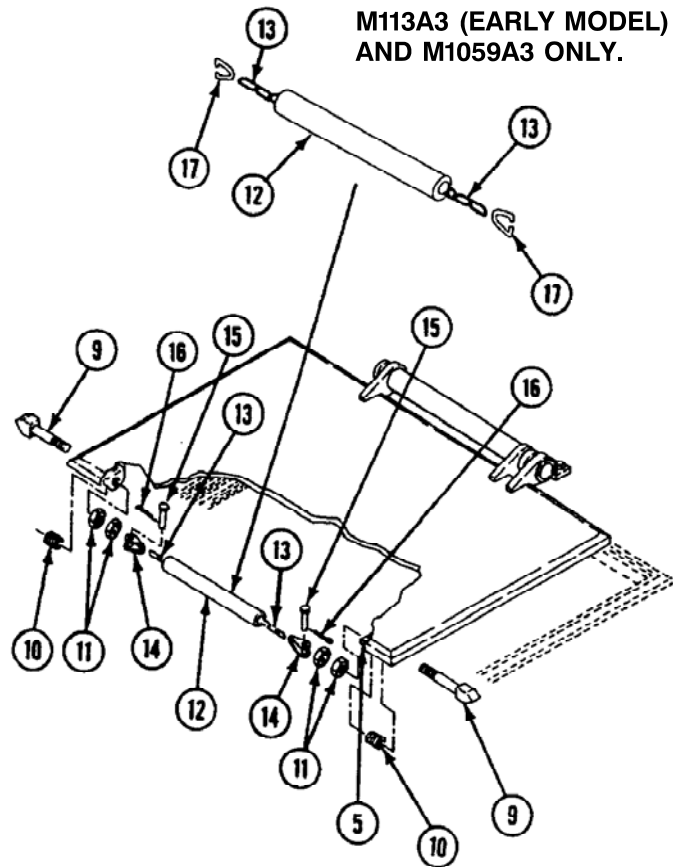

REPLACE CARGO HATCH INTERIOR LATCH (M113A3 AND M1059A3 ONLY) — Continued

0475 00

ADJUSTMENT

NOTE

Cargo hatch cover should fit tightly and evenly along all four sides.

1. Remove or add washers (1) between two brackets (2) and the cargo hatch cover (3), as needed, to establish a proper seal and correct latch engagement.
2. If cargo hatch cover does not seal correctly, remove required number of washers (1), equally, from both brackets (2) to tighten seal.
3. If cargo hatch cover (3) is too tight to latch correctly, add required number of washers (1), equally, to both brackets (2) to obtain proper latch engagement.
4. Position bracket (2) so that latch (4) engages striker (5) within 3/8 to 5/8 inch (10-16 mm).
5. **TIGHTEN EIGHT SCREWS (6) TO 22-24 LB-FT (30-37 N•m) TORQUE.**

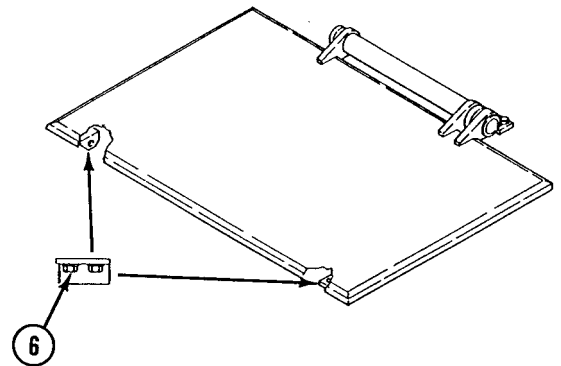
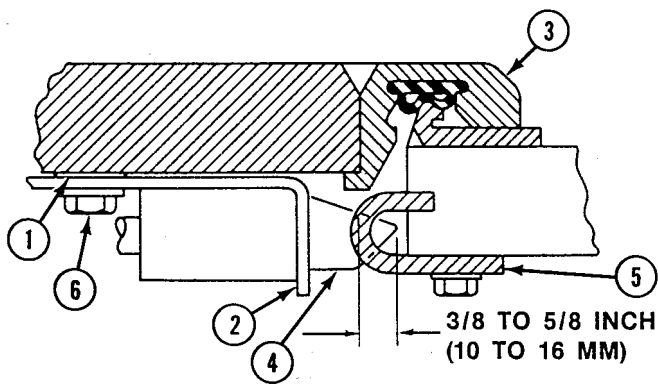

END OF TASK

REPLACE CARGO HATCH SEALS (M113A3 AND M1059A3 ONLY)

0478 00

THIS WORK PACKAGE COVERS:

- Removal (page 0478 00-1).
- Installation (page 0478 00-1).

INITIAL SETUP:

Maintenance Level

Unit

References

See your -10

Tools and Special Tools

General Mechanic's Tool Kit (WP 0926 00, Item 65)

Equipment Condition

- Engine stopped (see your -10)
- Carrier blocked (see your -10)
- Cargo hatch open (see your -10)

Personnel Required

Unit Mechanic

REMOVAL

1. Remove two short seals (1) and two long seals (2) from cover (3). Discard seals.

INSTALLATION

1. Install two new long seals (2) and two new short seals (1) on cover (3). Press seals into place.

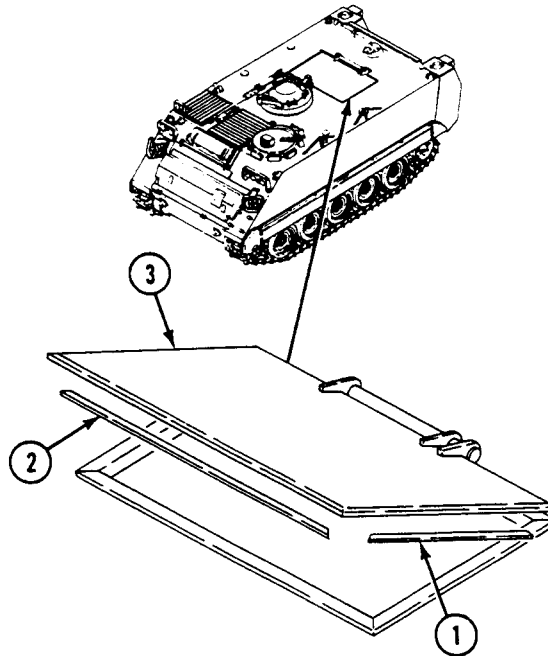

FOLLOW-THROUGH STEPS

1. Close cargo hatch (see your -10).

END OF TASK

REPLACE CARGO HATCH COVER (M113A3 AND M1059A3 ONLY)

0479 00 ■

THIS WORK PACKAGE COVERS:

Removal (page 0479 00-2).
 Installation (page 0479 00-3).

INITIAL SETUP:

Maintenance Level

Unit

References

See your -10

Tools and Special Tools

General Mechanic's Tool Kit (WP 0926 00, Item 65)
 Socket Wrench Set (WP 0926 00, Item 72)
 Torque Wrench (WP 0926 00, Item 78)

Equipment Condition

Engine stopped (see your -10)
 Carrier blocked (see your -10)
 Cargo hatch interior latch removed (WP 0475 00)
 Cargo hatch spall liner removed
 (M113A3 only) (WP 0509 00)

Materials/Parts

Grease (WP 0928 00, Item 12)
 Locknut

Personnel Required

Unit Mechanic
 Helper (H)

REPLACE CARGO HATCH COVER (M113A3 AND M1059A3 ONLY) —
Continued

0479 00

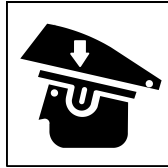
REMOVAL**WARNING**

Hatch cover may spring up and injure you. Open hatch cover and support in vertical position.

1. Remove two screws (1), washers (2), bracket (3), and shim(s) (4) from hull top plate.
2. Support cover (5). Remove 10 springs (6), shield (7), two fiber washers (8), and cover (5) from hinge brackets.
3. Remove two screws (9), washers (10), bracket (11), and shim(s) (12) from hull top plate.
4. Remove locknut (13) and screw (14) from cover (5). Discard locknut.

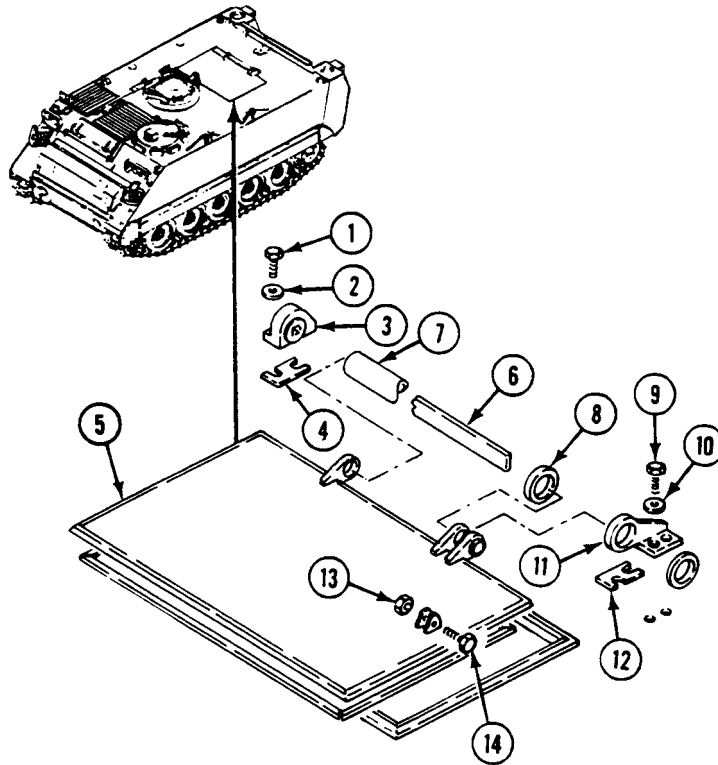

REPLACE CARGO HATCH COVER (M113A3 AND M1059A3 ONLY) —
Continued

0479 00

INSTALLATION

1. Install screw (1) in cover (2). Secure with new locknut (3).
2. Place shim(s) (4) and bracket (5) on hull top plate. Secure with two washers (6) and screws (7). TIGHTEN SCREWS TO 60-65 LB-FT (81-88 N•m) TORQUE.
3. Align cover (2) with hinge brackets. Install two fiber washers (8) and shield (9).
4. Apply coat of grease to each spring (10). Install 10 springs in shield (9).
5. Place cover (2) in vertical position. Install shim(s) (11) and bracket (12). Secure with two washers (13) and screws (14). TIGHTEN SCREWS TO 60-65 LB-FT (81-88 N•m) TORQUE.

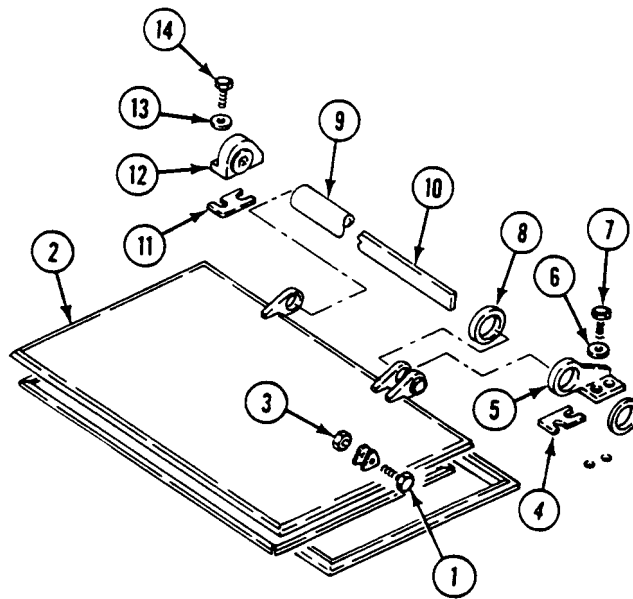

FOLLOW-THROUGH STEPS

1. Install cargo hatch interior latch (WP 0475 00).
2. Install cargo hatch spill liner (M113A3 only) (WP 0509 00).
3. Adjust latch (WP 0475 00).
4. Close cover. Check that cargo hatch cover is installed correctly.

END OF TASK

**REPLACE MORTAR HATCH EXTERIOR CATCHES AND BUMPERS
(M1064A3 ONLY)**

0480 00

THIS WORK PACKAGE COVERS:

- Removal (page 0480 00-1).
- Installation (page 0480 00-4).
- Adjust (page 0480 00-5).

INITIAL SETUP:

Maintenance Level

Unit

Personnel Required

Unit Mechanic

Tools and Special Tools

- General Mechanic's Tool Kit (WP 0926 00, Item 65)
- Socket Wrench Set (WP 0926 00, Item 73)
- Torque Wrench (WP 0926 00, Item 85)

References

See your -10

Materials/Parts

- Cotter pin (6)
- Lockwasher (20)
- Locknut (6)
- Spring pin (12)

Equipment Condition

- Engine stopped (see your -10)
 - Carrier blocked (see your -10)
-

REMOVAL

NOTE

Three exterior catches and bumpers are removed and installed the same way. The three chains and some brackets are not interchangeable and should be returned to the same assembly during installation. Left section is shown.

REPLACE MORTAR HATCH EXTERIOR CATCHES AND BUMPERS (M1064A3 ONLY) —
Continued

0480 00

1. Remove two cotter pins (1) from headed pins (2). Discard cotter pins.
2. Remove two headed pins (2) and clevises (3) from tee head bolt (4) and arm (5).
3. Remove two clevises (3) from chain (6).
4. Remove spring pin (7), handle (8), spring (9), and washer (10) from arm (5). Discard spring pin. Remove arm from hull top plate.
5. Remove two nuts (11) from tee head bolt (4). Remove tee head bolt and spring (12) from latch bolt bracket (13).

NOTE

Latch bolt bracket for center door section is mounted on right door section. Bracket for right door section does not have four spacers installed.

6. Remove four screws (14), lockwashers (15), spacers (16), and latch bolt bracket (13) from hull top plate. Discard lockwashers.

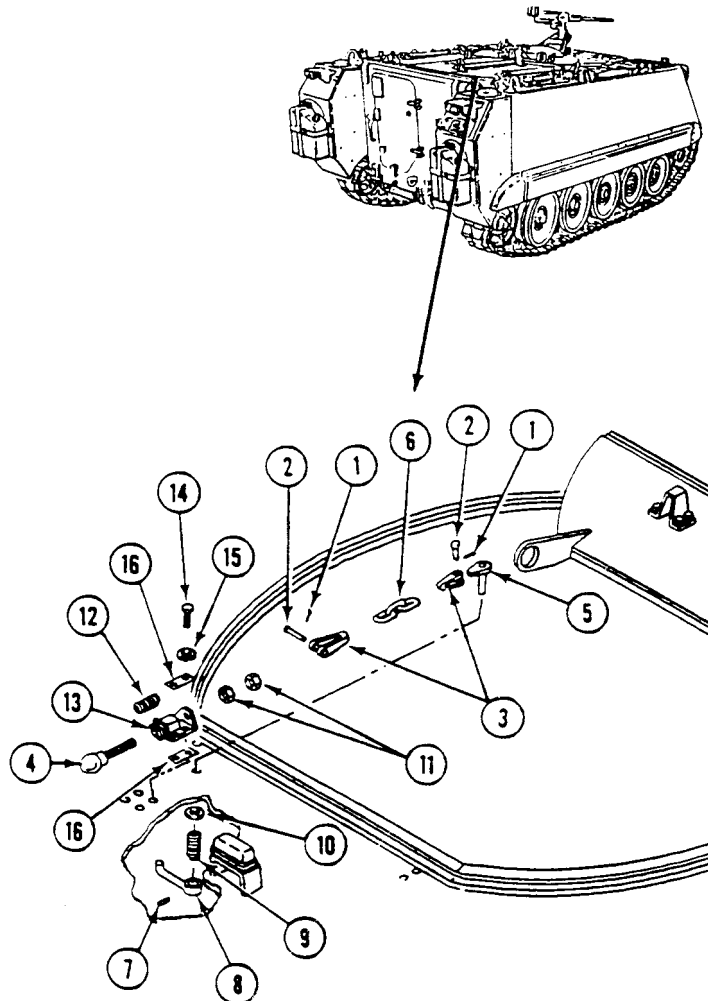

NOTE

Striker and catch for center and right door sections are both mounted on center door section.

7. Remove four screws (1), lockwashers (2), and catch (3) from door section (4). Discard lockwashers.

NOTE

Bumper for center door section is mounted on right door section.

8. Remove two locknuts (5), washers (6), bumper (7), and shims(s) (8) from hull bracket. Discard locknuts.

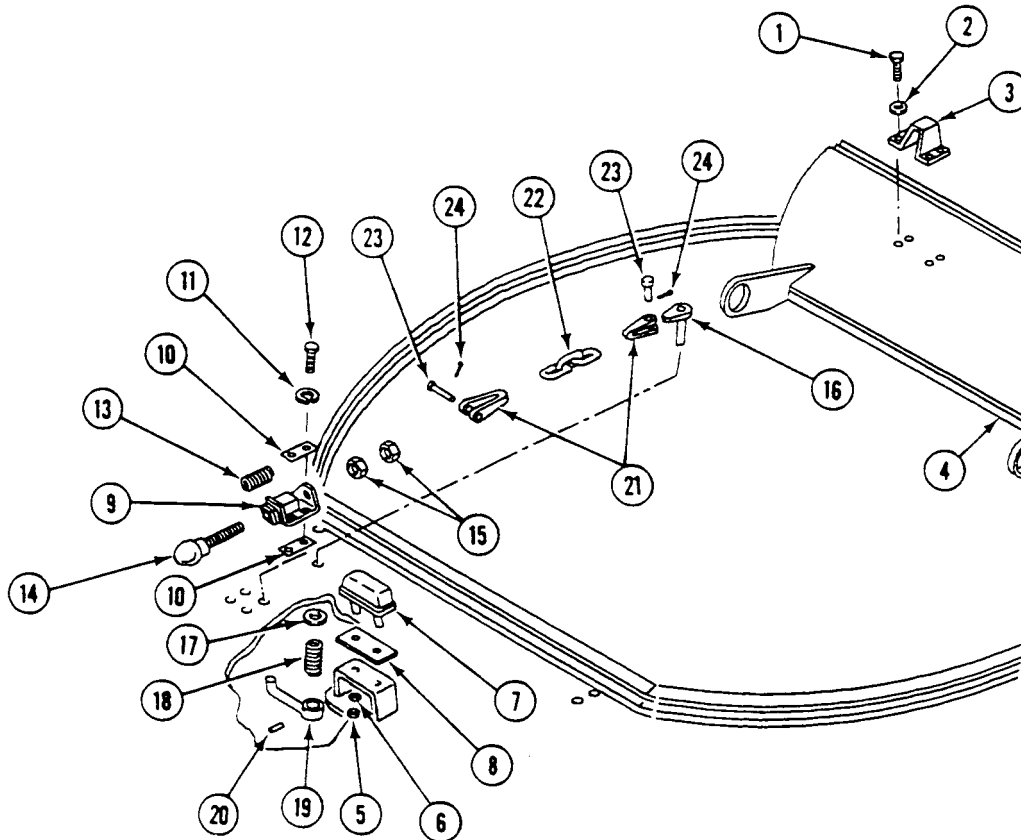

INSTALLATION

NOTE

Shim(s) are installed between bumper and hull bracket to remove all end play between cover and bumper.

1. Install shim(s) (8) and bumper (7) on hull bracket. Secure with two washers (6) and new locknuts (5).
2. Place catch (3) on door section (4). Secure with four new lockwashers (2) and screws (1). Do not torque screws at this time.

NOTE

Latch bolt bracket for center door section is mounted on right door section. Bracket for right door section does not have spacers installed.

3. Place latch bolt bracket (9) and two spacers (10) on hull top plate. Secure with new lockwashers (11) and four screws (12). Do not tighten screws at this time.
4. Install spring (13) and tee head bolt (14) on latch bolt bracket (9). Secure with two nuts (15).
5. Install arm (16) through hole in hull top plate. Install washer (17), spring (18), and handle (19) on arm. Secure with new spring pin (20).
6. Install two clevises (21) on chain (22). Secure clevises to arm (16) and tee head bolt (14) with two headed pins (23) and new cotter pins (24).

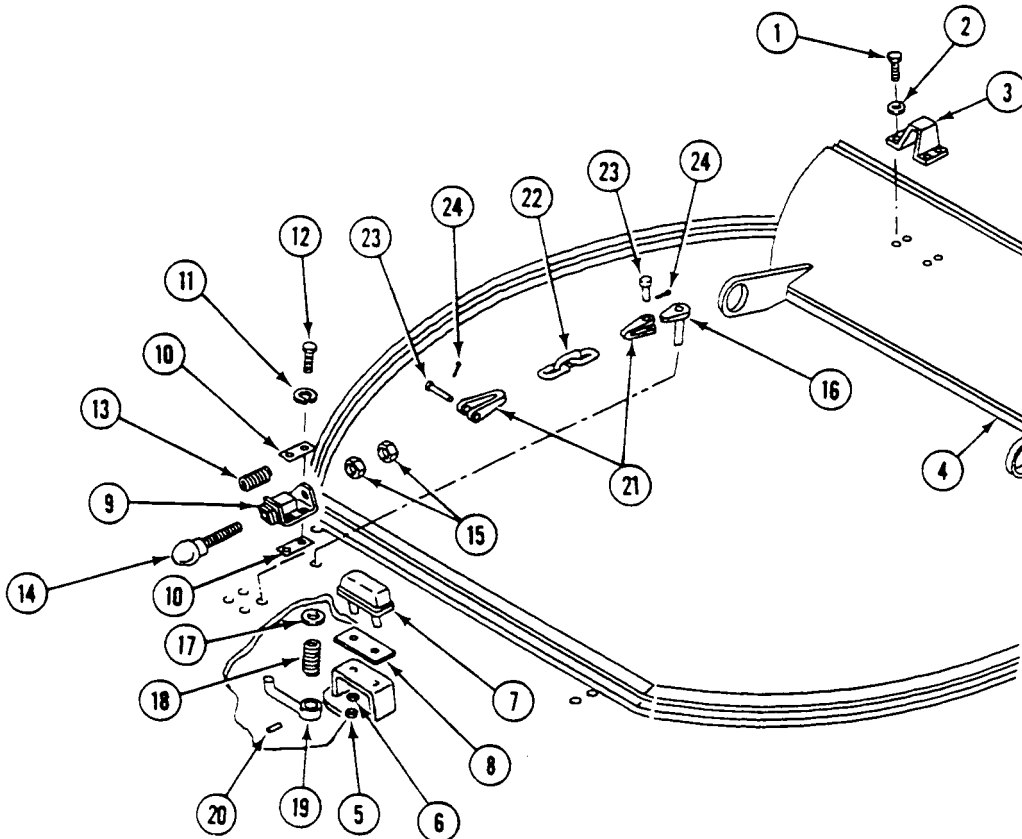

REPLACE MORTAR HATCH EXTERIOR CATCHES AND BUMPERS (M1064A3 ONLY) —
Continued

0480 00

ADJUSTMENT

1. Adjust LEFT and CENTER exterior latches as follows:

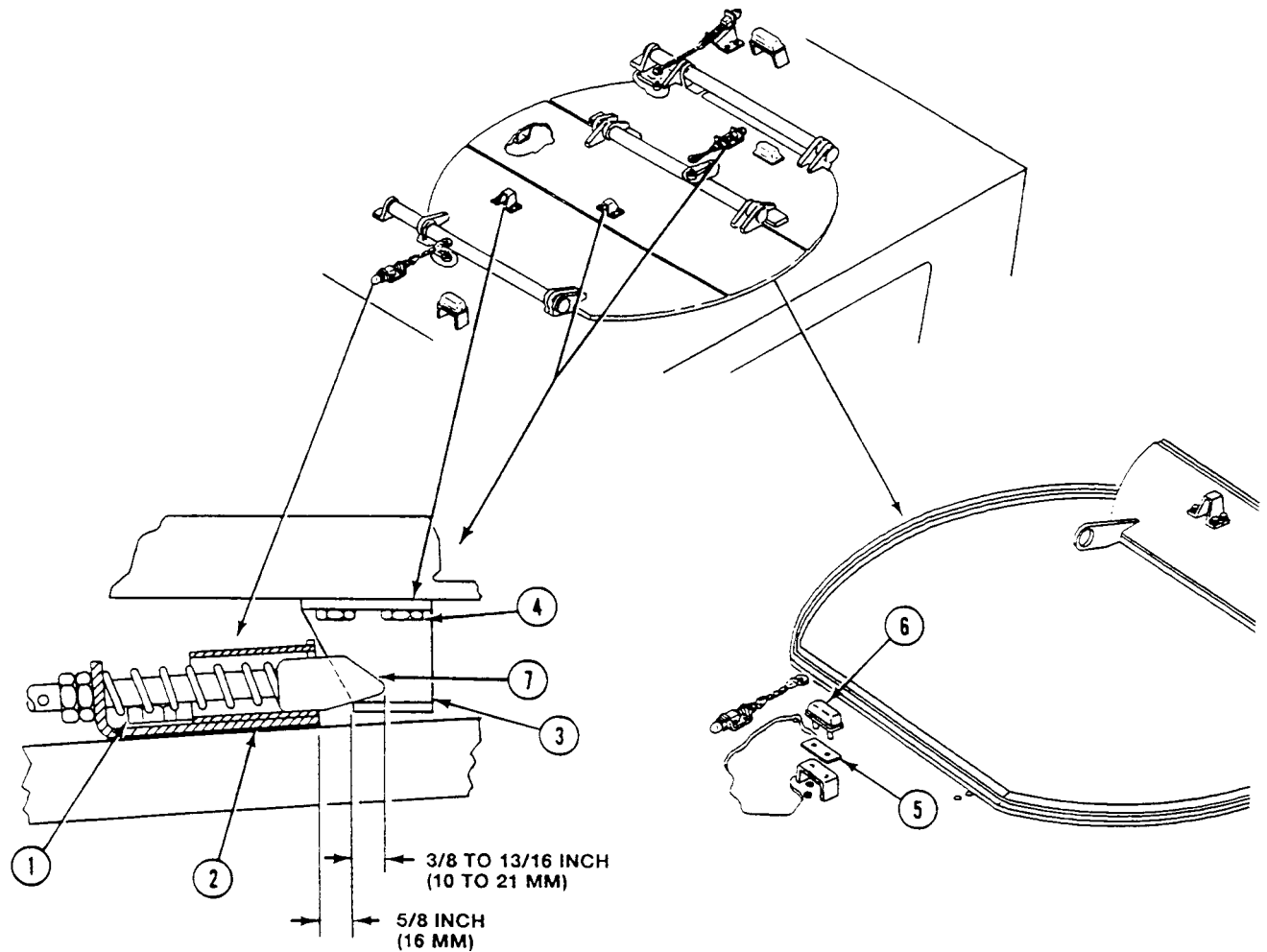
**LEFT AND CENTER EXTERIOR LATCH ADJUSTMENT**

- a. Open hatch sections.
- b. Loosen screws (1). Move latch bolt bracket (2) to get 5/8 in (16 mm) between end of bracket (2) and edge of catch (3).
- c. If above adjustment cannot be made, loosen screws (4) and move catch (3) to get above measurement.
- d. Remove or install shims (5) between bumper (6) and hull so that tee head bolt (7) protrudes into catch (3) a distance of 3/8 to 13/16 in (10 to 21 mm) with center door section firmly against bumper.
- e. Tighten screws (1) on bracket (2).
- f. TIGHTEN SCREWS (4) ON CATCH (3) AND TORQUE TO 360-420 LB-IN (41-47 N·m).

REPLACE MORTAR HATCH EXTERIOR CATCHES AND BUMPERS (M1064A3 ONLY) —
Continued

0480 00

2. Adjust RIGHT exterior latch as follows:

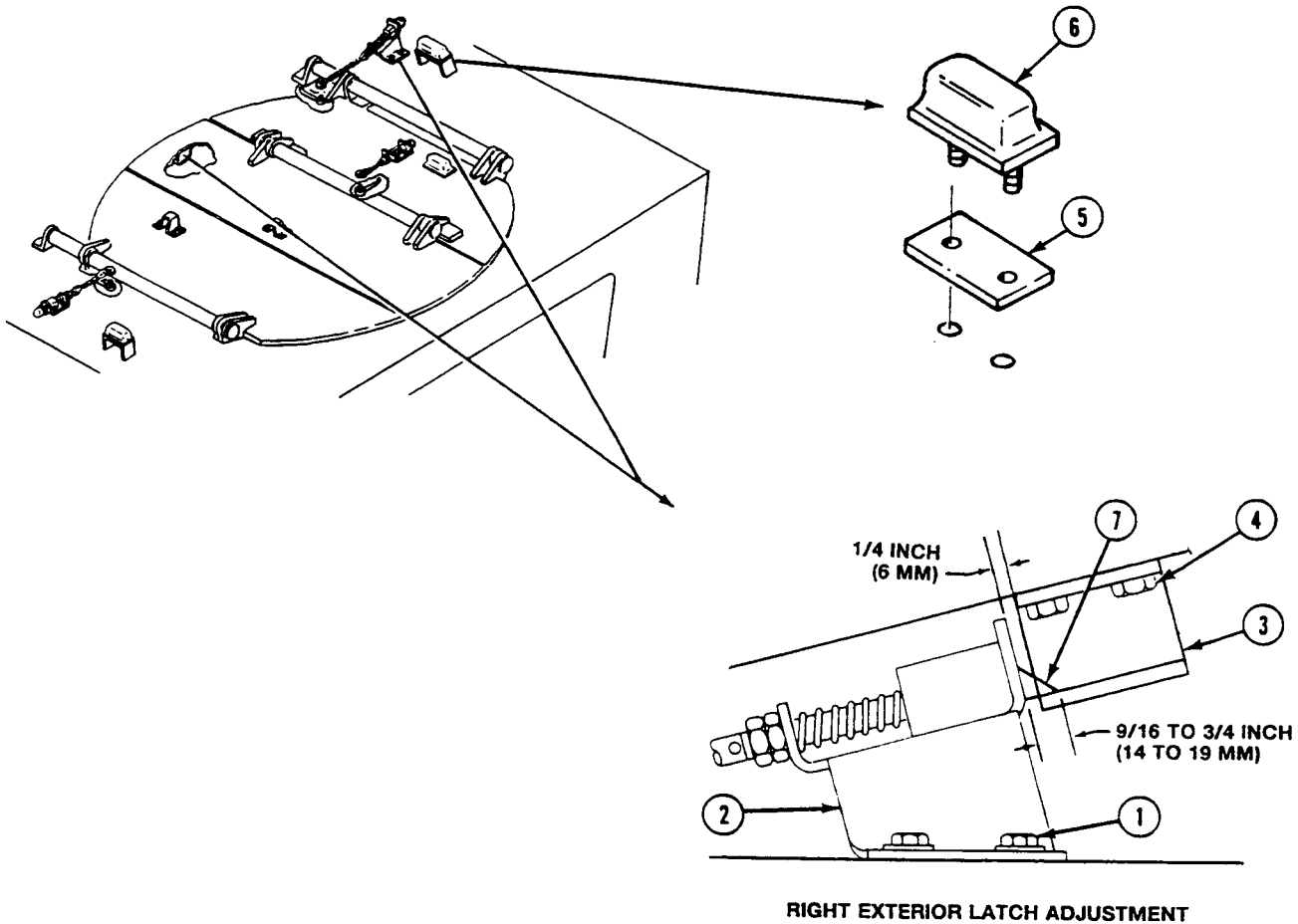

- a. Open hatch sections.
- b. Loosen screws (1). Move bracket (2) to get 1/4 in (6 mm) between end of bracket (2) and edge of catch (3).
- c. If above adjustment cannot be made, loosen screws (4) and move catch (3) to get above measurement.
- d. Remove or install shims (5) between bumper (6) and door section so that tee head bolt (7) protrudes into catch (3) a distance of 9/16 to 3/4 in (14 to 19 mm) with center and right door sections firmly against bumper.
- e. Tighten screws (1) on bracket (2).
- f. **TIGHTEN SCREWS (4) ON CATCH (3) AND TORQUE TO 360-420 LB-IN (41-47 N·m).**

FOLLOW-THROUGH STEPS

1. Open and close mortar hatch covers (see your -10). Check that covers are properly installed.

END OF TASK

REPLACE MORTAR HATCH INTERIOR RELEASE MECHANISMS (M1064A3 ONLY)

0481 00

THIS WORK PACKAGE COVERS:

- Removal (page 0481 00-1).
- Installation (page 0481 00-3).
- Adjustment (page 0481 00-4).

INITIAL SETUP:

Maintenance Level

Unit

Personnel Required

Unit Mechanic

Tools and Special Tools

General Mechanic's Tool Kit (WP 0926 00, Item 65)

References

See your -10

Materials/Parts

- Caulking compound (WP 0928 00, Item 14)
- Cotter pin (2)
- Lockwasher (8)
- Lockwasher (4)

Equipment Condition

- Engine stopped (see your -10)
 - Carrier blocked (see your -10)
 - Ramp lowered (see your -10)
-

REMOVAL

NOTE

There are three interior latch mechanisms. Inner chain and tube are longer than outside chains and tubes. Remove and install all three release mechanisms the same way. Left section is shown.

REPLACE MORTAR HATCH INTERIOR RELEASE MECHANISMS (M1064A3 ONLY) —
Continued

0481 00

1. Remove two cotter pins (1) from headed pins (2). Discard cotter pins.
2. Remove two headed pins (2) and clevises (3) from tee head bolts (4).
3. Remove two clevises (3) and tube (5) from chain (6).
4. Remove four nuts (7), two tee head bolts (4), and springs (8) from brackets (9).
5. Remove eight screws (10), lockwashers (11), two brackets (9), and washers (12) from cover section (13). Discard lockwashers.
6. Remove four screws (14), lockwashers (15), two strikes (16), and spacer(s) (17) from hull top plate. Discard lockwashers.

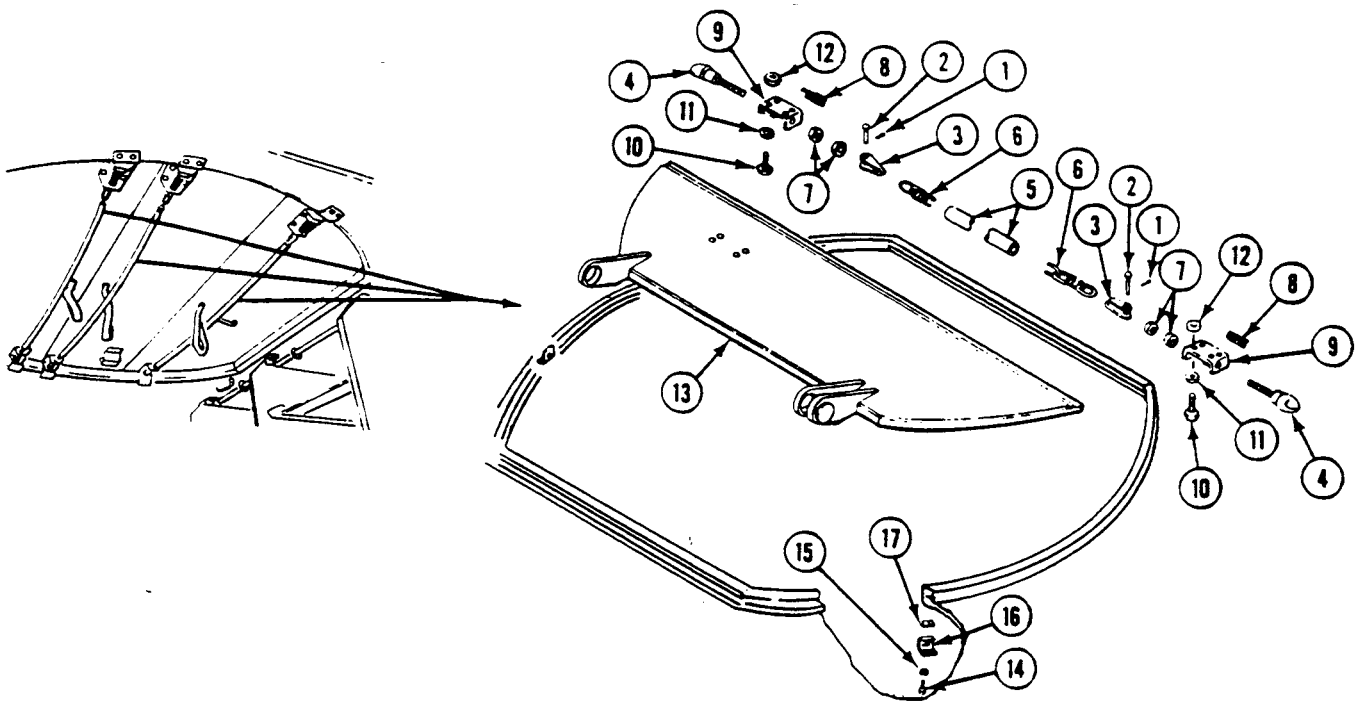

REPLACE MORTAR HATCH INTERIOR RELEASE MECHANISMS (M1064A3 ONLY) —
Continued

0481 00

INSTALLATION

1. Apply caulking compound to surfaces of strikes (1) that contact seal ledge.
2. Place spacer(s) (2) and two strikes (1) on hull top plate. Secure with four new lockwashers (3) and screws (4).
3. Place eight washers (5) and two brackets (6) on cover section (7). Secure with eight new lockwashers (8) and screws (9). Do not tighten screws.
4. Install two tee head bolts (10) and springs (11) on brackets (6). Secure with four nuts (12).

NOTE

Inner chain and tube are longer than outside chains and tubes. Check lengths of chains and tubes before installation.

5. Install tube (13) and two clevises (14) on chain (15). Secure clevises to tee head bolts (10) with headed pins (16) and new cotter pins (17).

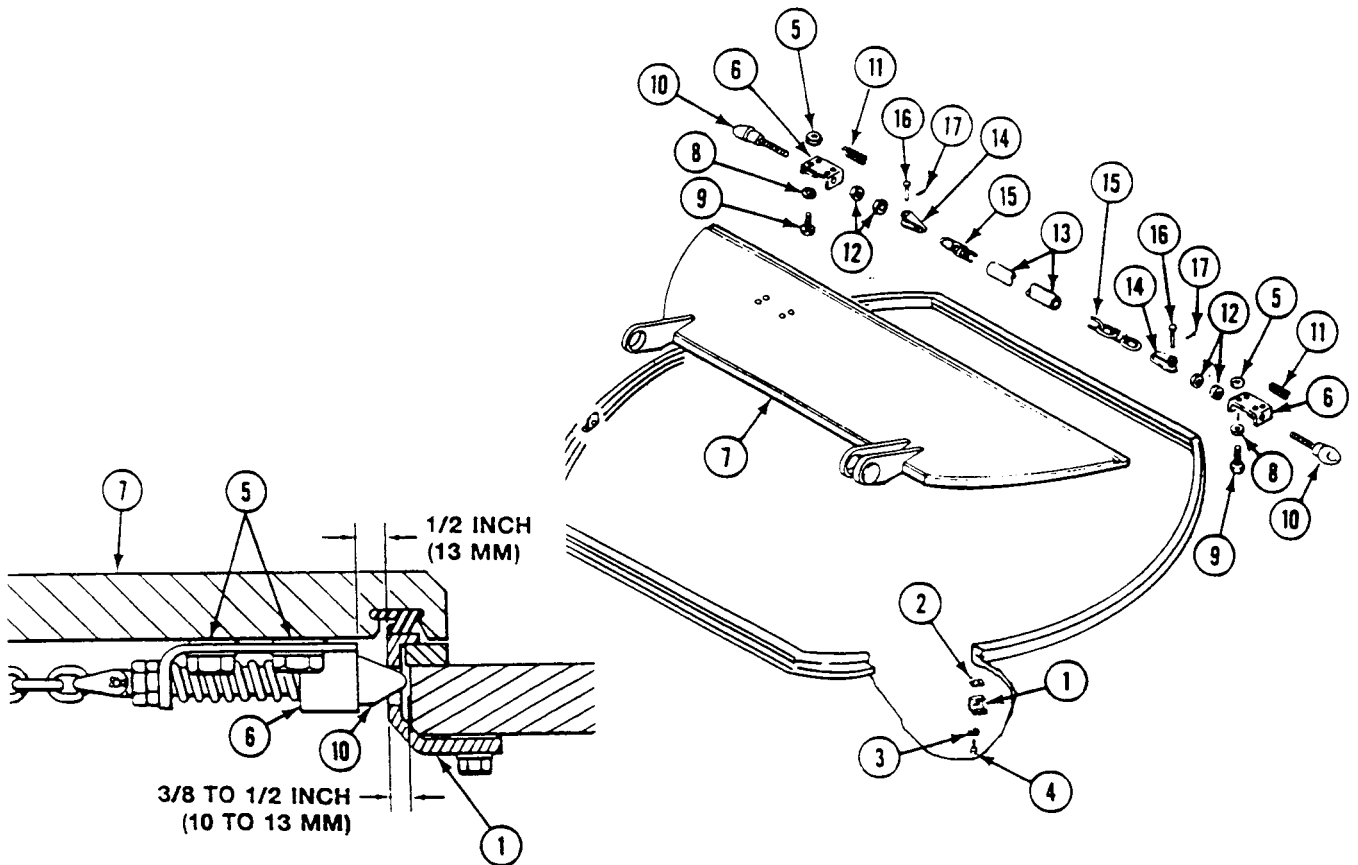

**REPLACE MORTAR HATCH INTERIOR RELEASE MECHANISMS (M1064A3 ONLY) —
Continued**

0481 00

ADJUSTMENT

1. Position each bracket (6) on cover (7) to get 1/2 inch (13 mm) maximum distance from strike (1) to bracket with cover closed.
2. Install washer(s) (5) between each bracket (6) and cover (7) until tee head bolt (10) inserts into strike (1) 3/8-1/2 in (10-13 mm) with cover closed.
3. Tighten four screws (9).

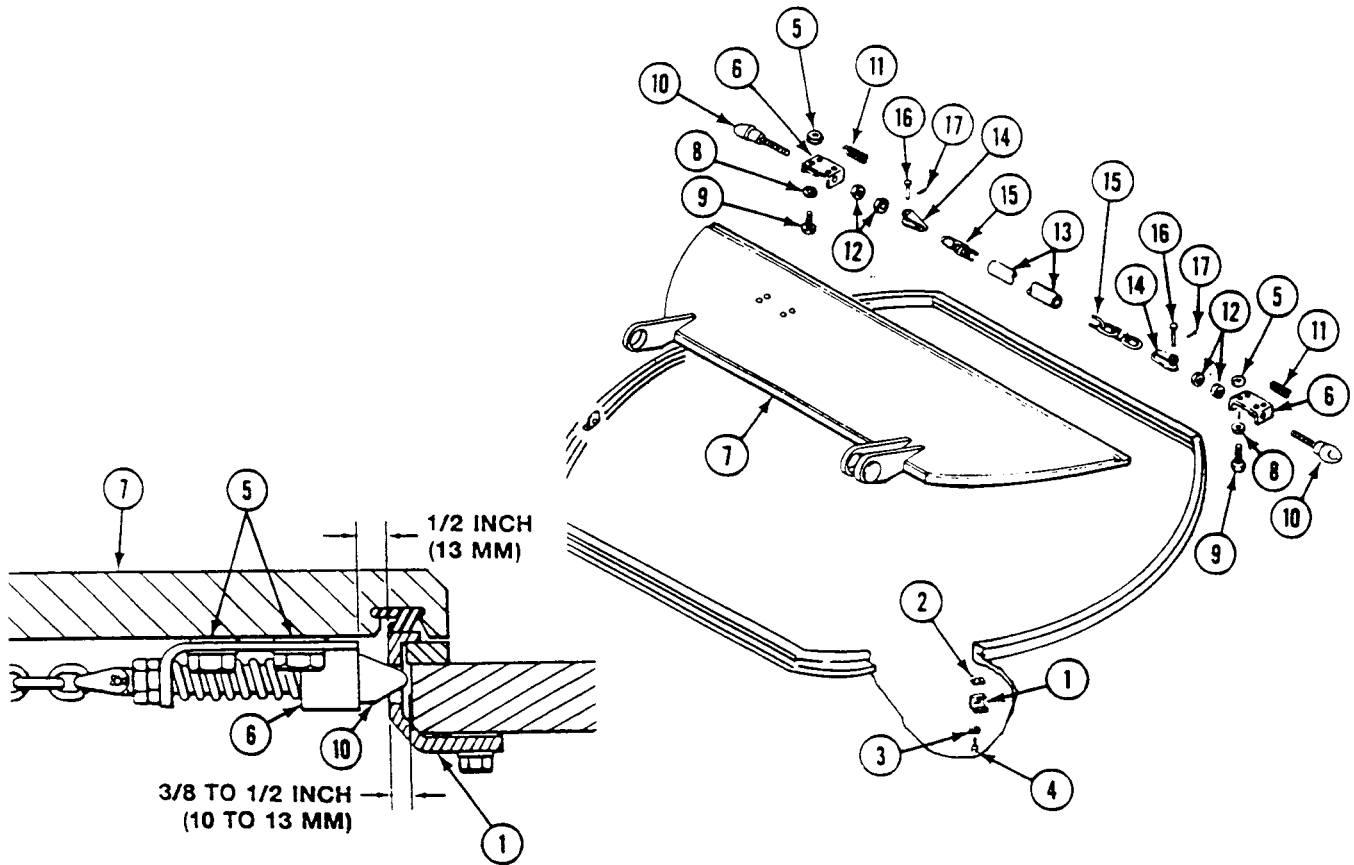

FOLLOW-THROUGH STEPS

1. Start engine (see your -10).
2. Raise and lock ramp (see your -10).
3. Stop engine (see your -10).

END OF TASK

REPLACE MORTAR HATCH COVERS (M1064A3 ONLY)

0482 00

THIS WORK PACKAGE COVERS:

Removal (page 0482 00-2).
 Installation (page 0482 00-3).

INITIAL SETUP:

Maintenance Level

Unit

References

See your -10

Tools and Special Tools

General Mechanic's Tool Kit (WP 0926 00, Item 65)
 Torque Wrench (WP 0926 00, Item 85)

Equipment Condition

Materials/Parts

Grease (WP 0928 00, Item 12)
 Seal (2)
 Seal (2)
 Seal (2)

Engine stopped (see your -10)
 Carrier blocked (see your -10)
 Ramp lowered (see your -10)

Personnel Required

Unit Mechanic
 Helper (H)

Mortar hatch interior release mechanism
 removed (WP 0481 00)
 Mortar hatch exterior catch removed (WP 0480 00)

REMOVAL

WARNING



Mortar hatch sections must be in a vertical position to release torsion spring tension before removing torsion spring brackets.

NOTE

There are three mortar hatch sections. Remove and install all three the same way. Left section is shown.

1. Remove two screws (1), washers (2), bracket (3), and spacers (4) from hull top plate.
2. Support door (5). Remove two springs (6), shield (7), two spacers (8), and door from hinges (9) and (10). Remove six springs from shield for right door section.
3. Remove four screws (11), washers (12), two hinges (9)(10), and spacers (13) from hull top plate.
4. Remove two seals (14) from door (5). Discard seal.

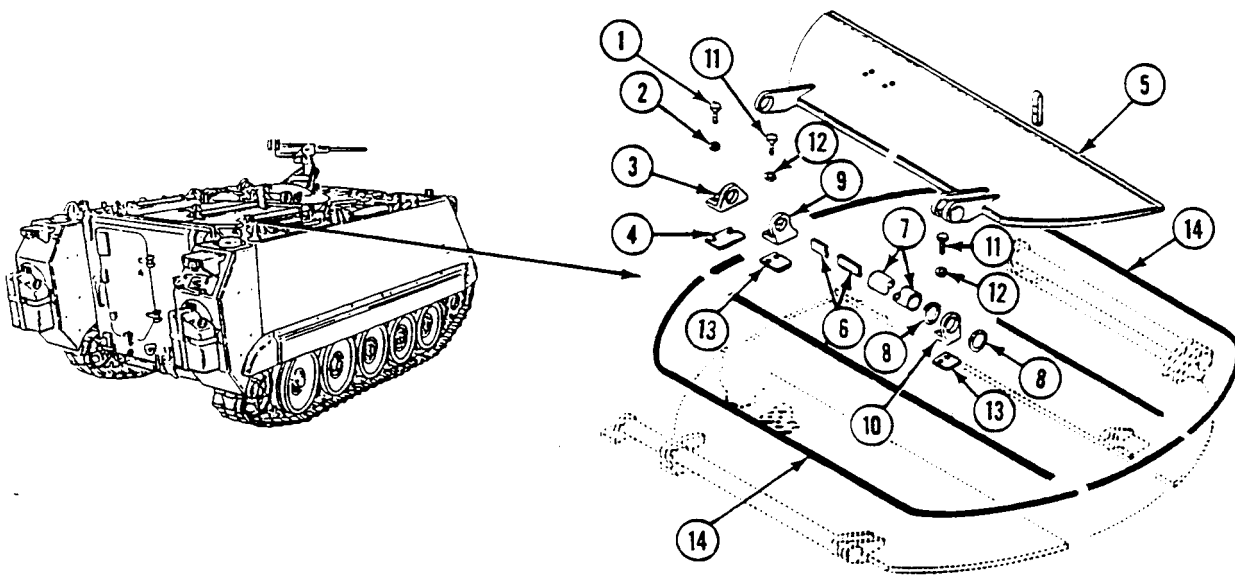

5. Remove two seals (1) and two seals (2) from center door. Discard seals.
6. Remove canvas strap (3) from door (4).

INSTALLATION

1. Install canvas strap (3) on door (4).
2. Place two new seals (5) over retaining groove in door (4). Press seals into place.
3. Install two new seals (1) and two new seals (2) on center door.
4. Place two spacers (6) and hinges (7)(8) on hull top plate. Secure with four washers (9) and screws (10). TIGHTEN SCREWS TO 60-65 LB-FT (81-88 N·m) TORQUE.
5. Align door (4) with hinges (7)(8). Install two spacers (11) and shield (12).
6. Apply light coat of grease to each spring (13). Install two springs in shield (12) for left door section. Install six springs in shield for right door section.
7. Place door (4) in vertical position. Install spacer(s) (14) and bracket (15). Secure with two washers (16) and screws (17). TIGHTEN SCREWS TO 60-65 LB-FT (81-88 N·m) TORQUE.

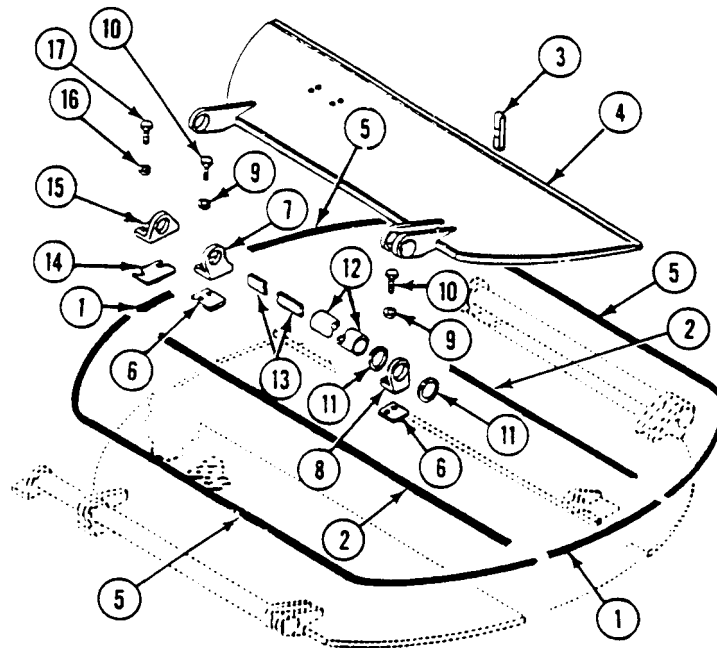
**FOLLOW-THROUGH STEPS**

1. Install mortar hatch exterior catch (WP 0480 00).
2. Install mortar hatch interior release mechanism (WP 0481 00).
3. Close cover. Check that mortar hatch door is properly installed.
4. Start engine (see your -10).
5. Raise and lock ramp (see your -10).
6. Stop engine (see your -10).

END OF TASK

REPLACE HOPPER HATCH LOCK ASSEMBLY (M58 ONLY)

0483 00

THIS WORK PACKAGE COVERS:

- Disassembly (page 0483 00-1).
- Assembly (page 0483 00-2).
- Adjustment (page 0483 00-2).

INITIAL SETUP:

Maintenance Level

Unit

Personnel Required

Unit Mechanic

Tools and Special Tools

General Mechanic's Tool Kit (WP 0926 00, Item 65)

References

See your -10

Materials/Parts

Locknut (2)
Seal

Equipment Condition

Engine stopped (see your -10)
Carrier blocked (see your -10)

DISASSEMBLY

1. Remove locknut (1), lock (2), key (3), washers (4), and spacer (5) from lock handle (6). Discard locknut.
2. Remove lock handle (6) and four washers (7) from shaft (8).
3. Remove preformed packing (9) from shaft (8). Discard preformed packing.

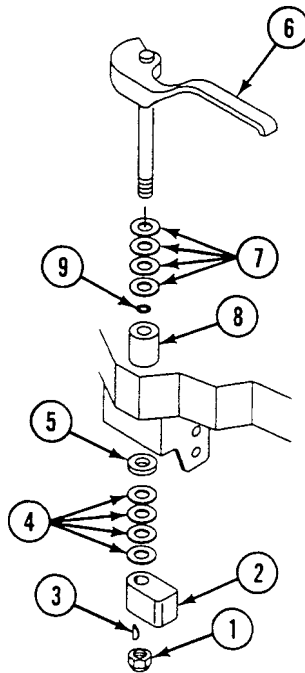

ASSEMBLY

1. Install new preformed packing (1) on shaft (2).
2. Install four washers (3) and lock handle (4) on shaft (2).
3. Install spacer (5), washers (6), key (7), lock (8), and new lock nut (9) on lock handle (4).

ADJUSTMENT

1. Use exterior washers (3) as required to achieve snug and even compression of seal.
2. Use interior washers (6) as required to position centerline of lock (8) within 1/8 inch of centerline of combat lock pin.

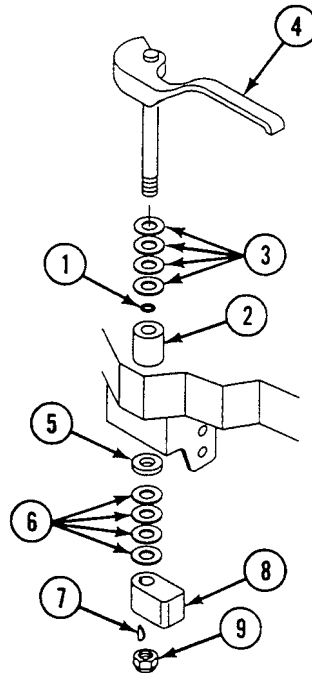
**END OF TASK**

REPLACE HOPPER HATCH (M58 ONLY)

0484 00

THIS WORK PACKAGE COVERS:

- Removal (page 0484 00-1).
 - Installation (page 0484 00-3).
 - Adjustment (page 0484 00-4).
-

INITIAL SETUP:

Maintenance Level

Unit

Personnel Required

Unit Mechanic
Helper

Tools and Special Tools

General Mechanic's Tool Kit (WP 0926 00, Item 65)

References

See your -10

Materials/Parts

Locknut (2)
Seal

Equipment Condition

Engine stopped (see your -10)
Carrier blocked (see your -10)

REMOVAL

WARNING

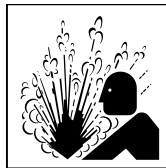

Personnel could be injured if they slip on oil or graphite on top of carrier. Clean up spills immediately. Personnel on top of carrier should always use three point stance.

1. Release hopper hatch lock (1). Raise hopper hatch cover (2) 3/4 up to unsprung position. Have helper support hatch.

CAUTION

Damage to equipment may occur if hopper hatch is not raised to 3/4 open position when removing retainer.

2. Remove two locknuts (3), screws (4), and retainer (5) from hinge brackets (6). Discard locknuts.
3. Have helper support hopper hatch cover (2). Remove 17 springs (7), shield (8), and two fiber washers (9) from hopper hatch cover and hinge brackets (6).
4. Remove hopper hatch cover (2) from carrier top plate.
5. Remove four screws (10), washers (11), two brackets (6), and shims (12) from carrier top plate.
6. Remove seal (13) from hopper hatch cover (2). Discard seal.
7. Using cable assembly (14), lift screen (15) from hopper opening.
8. Remove two screws (16), washers (17), and cable assembly (14) from screen (15).

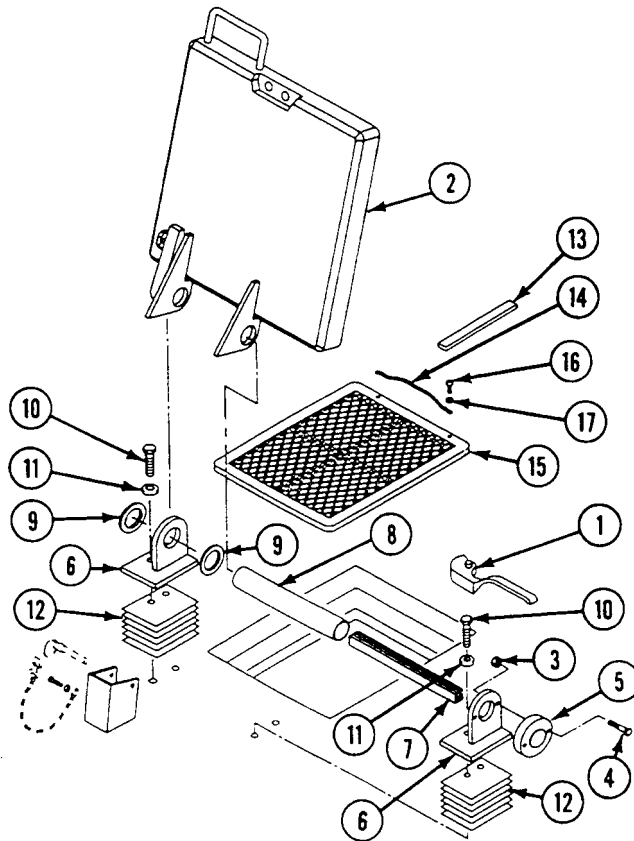

INSTALLATION

WARNING

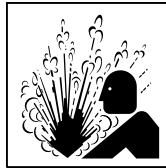

Personnel could be injured if they slip on oil or graphite on top of carrier. Clean up spills immediately. Personnel on top of carrier should always use three point stance.

1. Install cable assembly (1), two washers (2), and screws (3) on screen (4).
2. Lower screen (4) into position using cable assembly (1).
3. Install new seal (5) on hopper hatch cover (6). Bend seal retainers to secure seal.

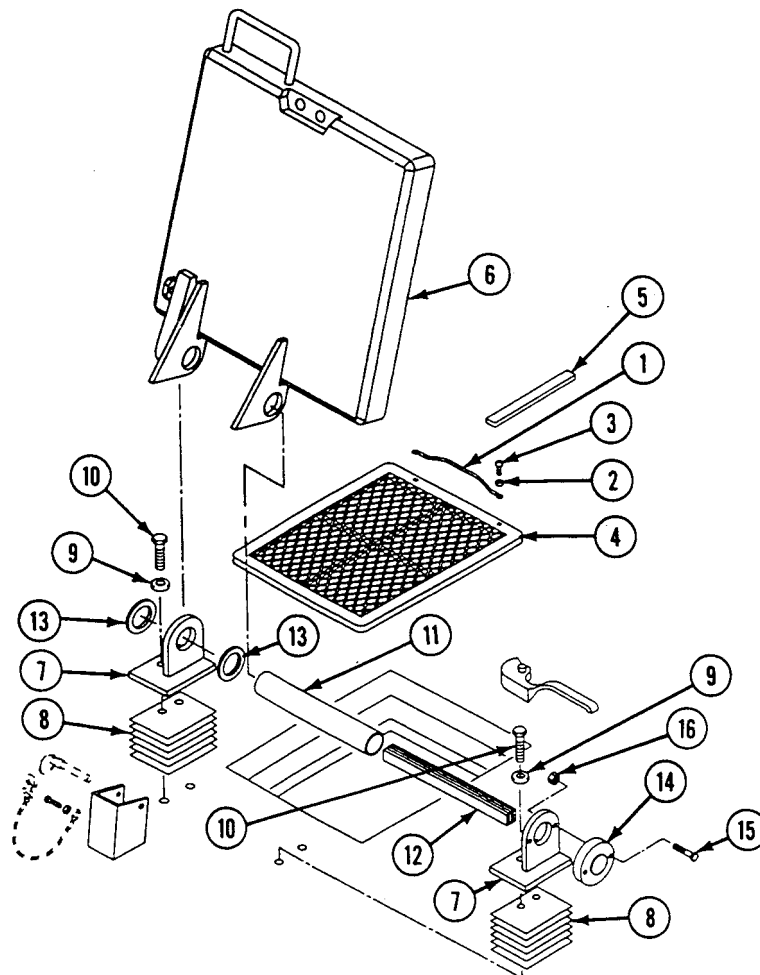

4. Install two hinge brackets (7), shims (8), four washers (9), and screws (10) on carrier top plate.
5. TIGHTEN FOUR SCREWS (10) ON HINGE BRACKETS (7) TO 76-83 LB-FT (103-112 N·m) TORQUE.
6. Position hopper hatch cover (6) between hinge brackets (7).
7. Install shield (11), 17 springs (12), and two fiber washers (13) in hopper hatch cover (6) and hinge brackets (7).

CAUTION

Damage to equipment may occur if hopper hatch is not raised to 3/4 open position when installing retainer.

8. Have helper hold hopper hatch cover (6) at 3/4 open unsprung position. Install retainer (14), two screws (15), and new locknuts (16) on hinge bracket (7).

ADJUSTMENT

1. Use shims (8) as required to achieve snug and even compression of seal (5).

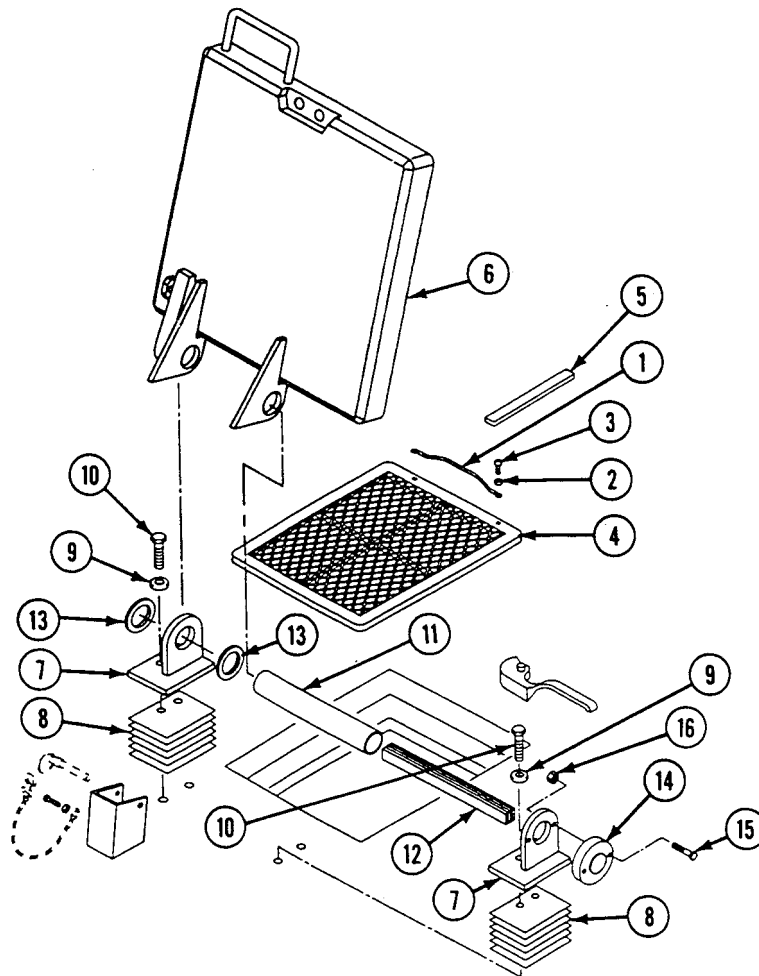

END OF TASK

REPLACE TURBINE ACCESS DOOR (M58 ONLY)

0485 00

THIS WORK PACKAGE COVERS:

Removal (page 0485 00-2).
Installation (page 0485 00-2).

INITIAL SETUP:

Maintenance Level

Unit

Personnel Required

Unit Mechanic

References

See your -10

Tools and Special Tools

General Mechanic's Tool Kit (WP 0926 00, Item 65)

Equipment Condition

Engine stopped (see your -10)
Carrier blocked (see your -10)

REMOVAL

NOTE

The hinge pins are not removed from the hinge halves for this task.

1. Remove four screws (1), washers (2), and two hinge halves (3) from turbine access door (4).
2. Remove eight screws (5), washers (6), and turbine access door (4) from carrier.
3. Remove strap assembly (7) from turbine access door (4).

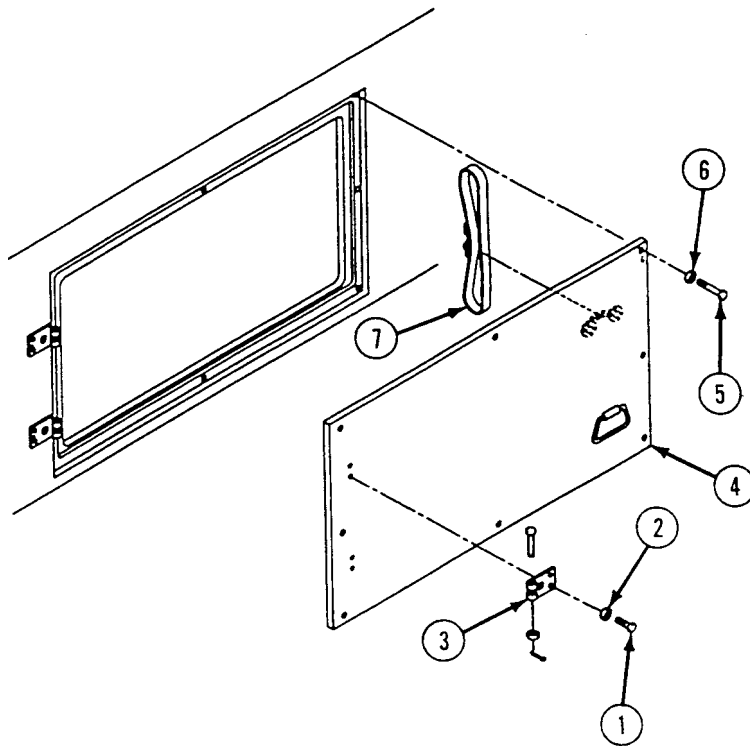

INSTALLATION

1. Install strap assembly (7) on turbine access door (4).
2. Install turbine access door (4), eight washers (6), and screws (5) on carrier.

REPLACE TURBINE ACCESS DOOR (M58 ONLY) — Continued

0485 00

3. Install two hinge halves (3), four washers (2), and screws (1) on turbine access door (4).

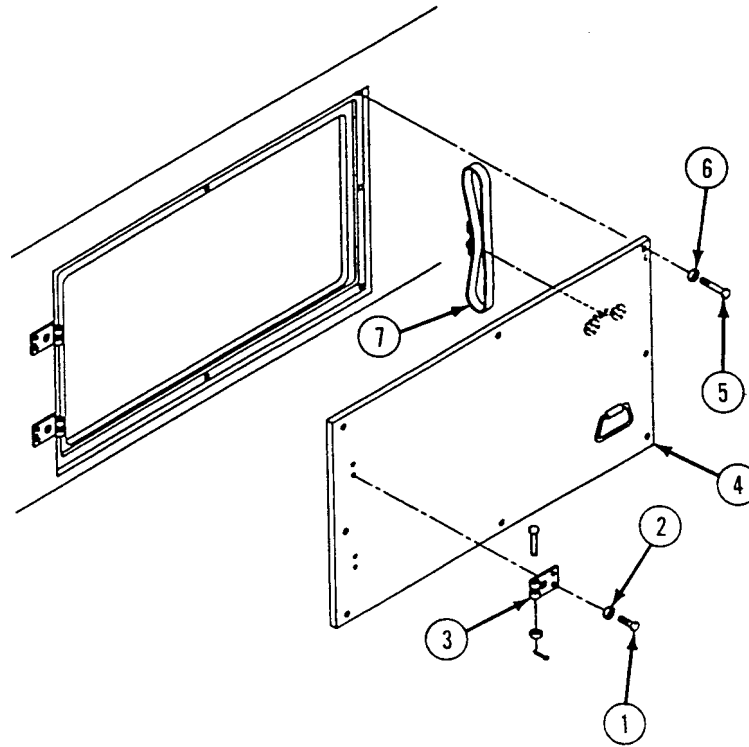
**END OF TASK**

REPLACE TURBINE ACCESS DOOR GASKET (M58 ONLY)

0486 00

THIS WORK PACKAGE COVERS:

Removal (page 0486 00-1).
 Installation (page 0486 00-1).

INITIAL SETUP:

Maintenance Level

Unit

Personnel Required

Unit Mechanic

Tools and Special Tools

General Mechanic's Tool Kit (WP 0926 00, Item 65)

References

See your -10

Materials/Parts

Adhesive (WP 0928 00, Item 4)
 Gasket

Equipment Condition

Engine stopped (see your -10)
 Carrier blocked (see your -10)
 Turbine access door removed (WP 0485 00)

REMOVAL

1. Remove gasket (1) from carrier. Discard gasket.

INSTALLATION

1. Apply adhesive to cleaned mating surfaces. Trim gasket if needed.
2. Install new gasket (1) with gasket seam positioned nearest carrier top plate.

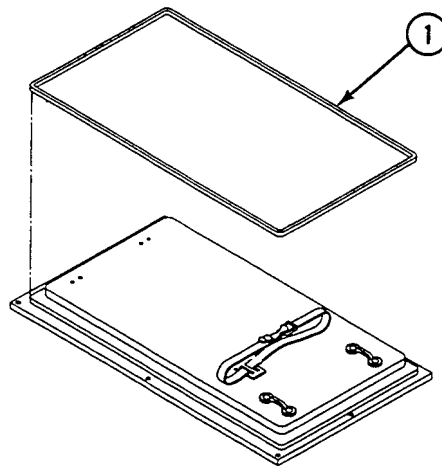

FOLLOW-THROUGH STEPS

1. Install turbine access door (WP 0485 00).

END OF TASK

REPLACE TURBINE ACCESS DOOR HINGES (M58 ONLY)

0487 00

THIS WORK PACKAGE COVERS:

Removal (page 0487 00-2).
 Installation (page 0487 00-3).

INITIAL SETUP:

Maintenance Level

Unit

Personnel Required

Unit Mechanic

Tools and Special Tools

General Mechanic's Tool Kit (WP 0926 00, Item 65)

References

See your -10

Materials/Parts

Sealing compound (WP 0928 00, Item 56)
 Cotter pins

Equipment Condition

Engine stopped (see your -10)
 Carrier blocked (see your -10)

REMOVAL

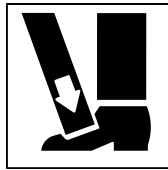
WARNING

Do not remove screws securing door to hull. It may fall and injure personnel. Tag door handle to warn those who want access to turbine compartment.

1. Remove eight screws (1), washers (2), and two hinges (3) from carrier and turbine access door (4).
2. Remove two cotter pins (5), shoulder pins (6), and washers (7) from four hinge halves (8). Discard cotter pins.

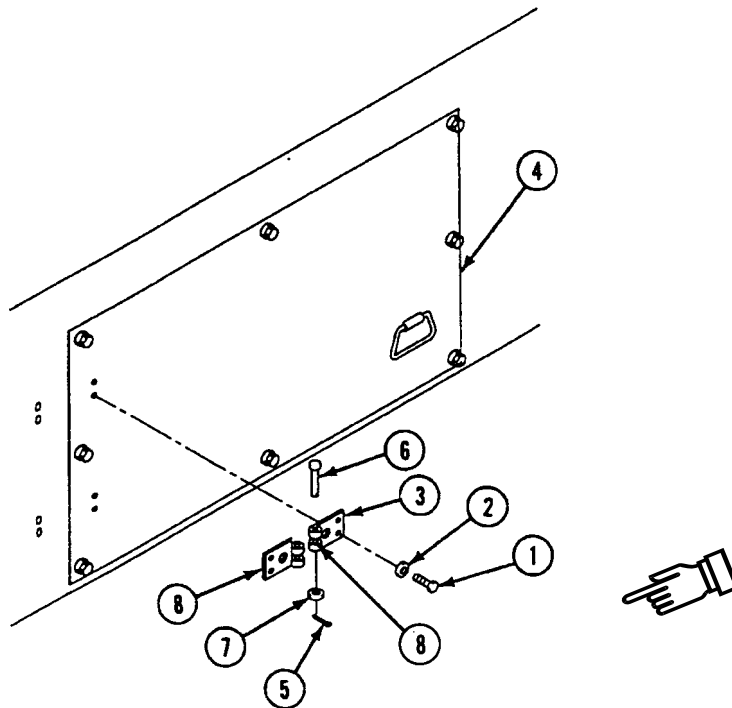

INSTALLATION

1. Assemble four hinge halves (8) and install two shoulder pins (6), washers (7), and new cotter pins (5). Install washers as required to take up excess space between hinge halves (8).
2. Apply sealing compound to screws before installing in hinges.
3. Install two hinges (3), eight washers (2), and screws (1) on turbine access door (4) and carrier.

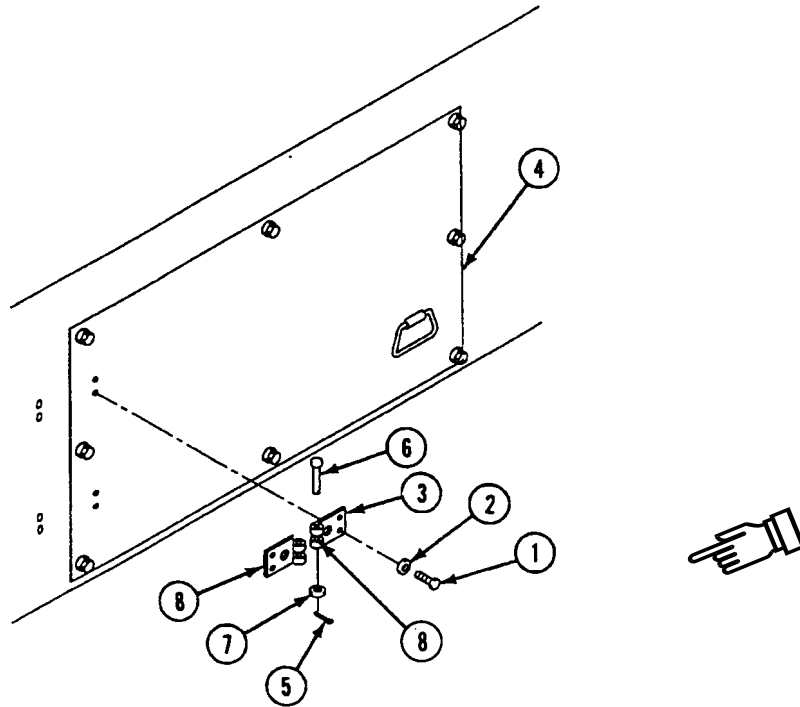

END OF TASK

**REPLACE COMMANDER'S CUPOLA CUSHIONING PAD AND HANDLE
(M113A3, M1059A3, M58, AND M1064A3 ONLY)**

0488 00

THIS WORK PACKAGE COVERS:

Removal (page 0488 00-1).
Installation (page 0488 00-2).

INITIAL SETUP:

Maintenance Level

Unit

References

See your -10

Tools and Special Tools

General Mechanic's Tool Kit (WP 0926 00, Item 65)
Torque Wrench (WP 0926 00, Item 80)

Equipment Condition

Engine stopped (see your -10)
Carrier blocked (see your -10)
Hatch cover open (see your -10)

Personnel Required

Unit Mechanic

REMOVAL

1. Remove two screws (1), washers (2), and handle (3) from hull ceiling next to commander's cupola.
2. Remove six screws (5), washers (4), and pad (6) from commander's cupola.

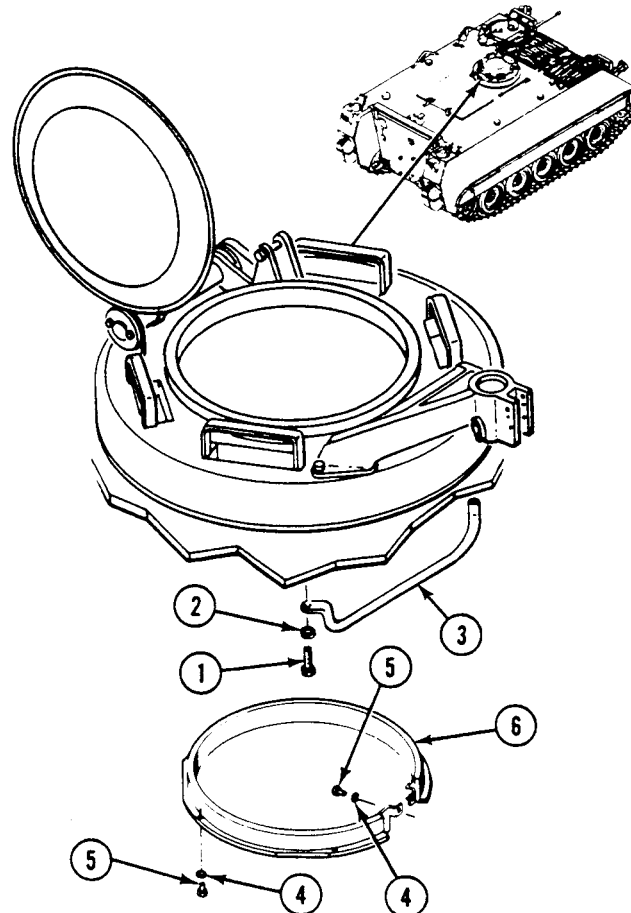

**REPLACE COMMANDER'S CUPOLA CUSHIONING PAD AND HANDLE (M113A3,
M1059A3, M58, AND M1064A3 ONLY) — Continued**

0488 00

INSTALLATION

1. Align pad (6) with holes in commander's cupola. Secure with six washers (4) and screws (5).
2. Align handle (3) with holes in hull ceiling next to commander's cupola. Secure with two washers (2) and screws (1).
TIGHTEN SCREWS TO 120-130 LB-FT (163-176 N·m) TORQUE.

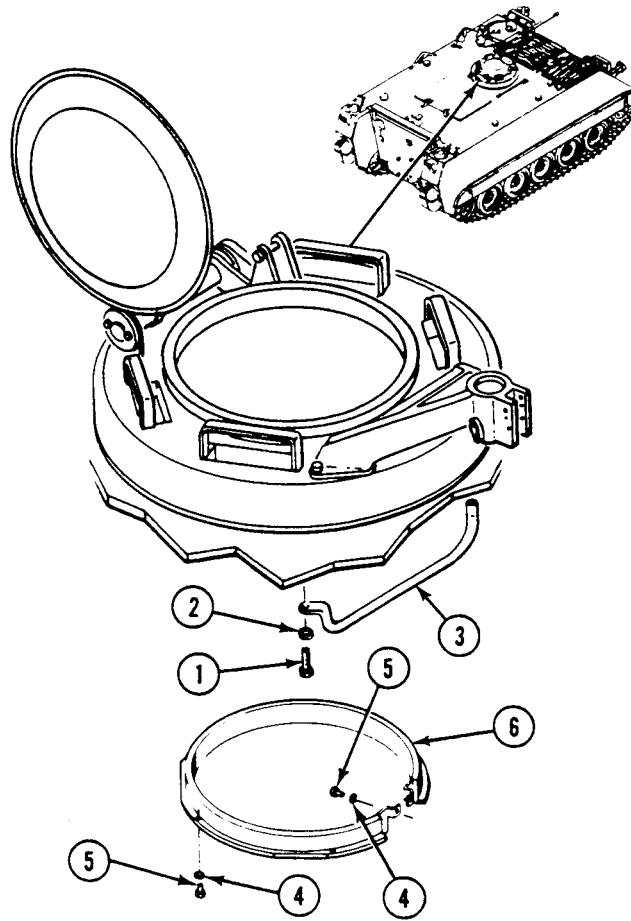
**FOLLOW-THROUGH STEPS**

1. Close hatch cover (see your -10).

END OF TASK

REPLACE COMMANDER'S CUPOLA AZIMUTH LOCK (M113A3, M1059A3, M58 AND M1064A3 ONLY)

0489 00

THIS WORK PACKAGE COVERS:

Removal (page 0489 00-1).
 Installation (page 0489 00-2).

INITIAL SETUP:

Maintenance Level

Unit

Personnel Required

Unit Mechanic

Tools and Special Tools

General Mechanic's Tool Kit (WP 0926 00, Item 65)

References

See your -10

Materials/Parts

Spring pin

Equipment Condition

Engine stopped (see your -10)
 Carrier blocked (see your -10)

REMOVAL

1. Remove spring pin (1) and handle (2) from pin (3). Discard spring pin.
2. Remove bushing (4), washer(s) (5), pin (3), and spring (6) from hull ceiling below commander's cupola.

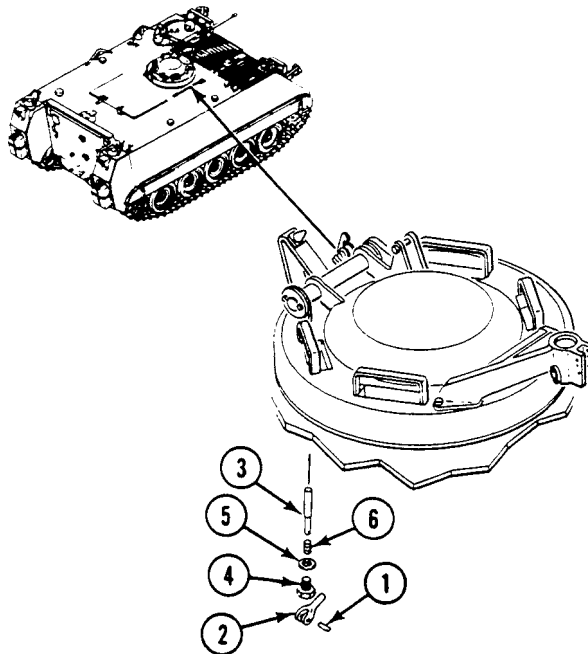

REPLACE COMMANDER'S CUPOLA AZIMUTH LOCK (M113A3, M1059A3, M58 AND M1064A3 ONLY) — Continued

0489 00

INSTALLATION**NOTE**

Use the least number of washers needed to release pin in unlocked position.

1. Install spring (6), pin (3), washer(s) (5), and bushing (4) in hull ceiling below commander's cupola.
2. Align handle (2) with pin (3). Secure with new spring pin (1).

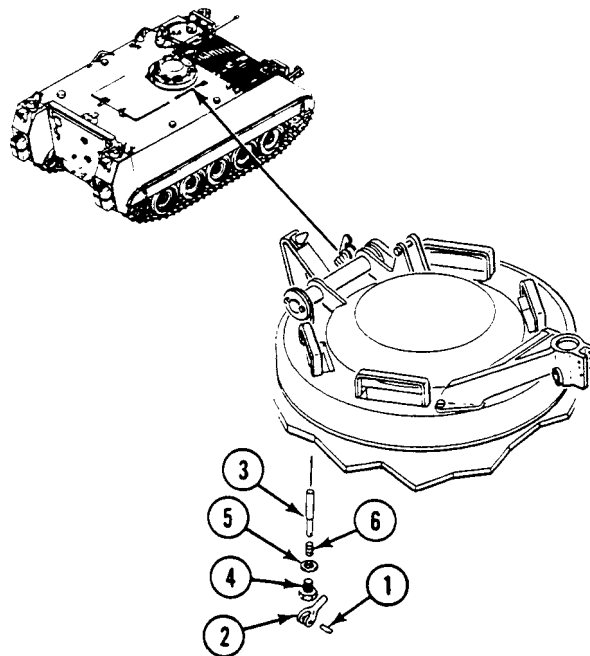
**FOLLOW-THROUGH STEPS**

1. Operate azimuth lock (see your -10). Check that cupola can be locked and unlocked. If cupola does not unlock, add more washers (5) under bushing (4).

END OF TASK

**REPLACE COMMANDER'S CUPOLA VISION BLOCK LOCKS AND SEALS
(M113A3 AND M1059A3, M58 ONLY)**

0490 00

THIS WORK PACKAGE COVERS:

Removal (page 0490 00-1).
Installation (page 0490 00-3).

INITIAL SETUP:

Maintenance Level

Unit

Personnel Required

Unit Mechanic

Tools and Special Tools

General Mechanic's Tool Kit (WP 0926 00, Item 65)

References

See your -10

Materials/Parts

Adhesive (WP 0928 00, Item 4)
Seal
Spring pin

Equipment Condition

Engine stopped (see your -10)
Carrier blocked (see your -10)
Vision block removed (see your -10)

REMOVAL

NOTE

**There are five vision blocks on the commander's cupola. Each block has two locks and one seal.
Task is for one lock and one seal.**

REPLACE COMMANDER'S CUPOLA VISION BLOCK LOCKS AND SEALS (M113A3 AND M1059A3, M58 ONLY) — Continued

0490 00

1. Remove thumbscrew (1) from arm (2).
2. Remove spring pin (3) from arm (2). Discard pin.
3. Remove arm (2) and washer (4) from cupola bracket.
4. Scrape seal (5) from vision block opening.

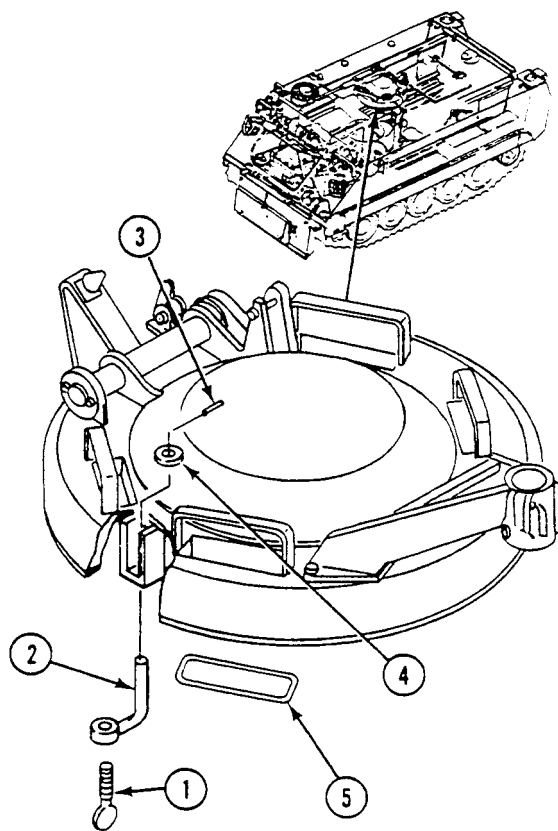

REPLACE COMMANDER'S CUPOLA VISION BLOCK LOCKS AND SEALS (M113A3 AND M1059A3, M58 ONLY) — Continued

0490 00

INSTALLATION**NOTE**

Surface on seal marked **BOND THIS SIDE** should be glued to cupola.

1. Apply adhesive to cleaned mating surface around vision block opening. Allow adhesive to become tacky. Install new seal (5) on cupola.
2. Install arm (2) and washer (4) in cupola bracket. Secure with new spring pin (3).
3. Install thumbscrew (1) in arm (2). Deform first thread of thumbscrew to prevent easy removal.

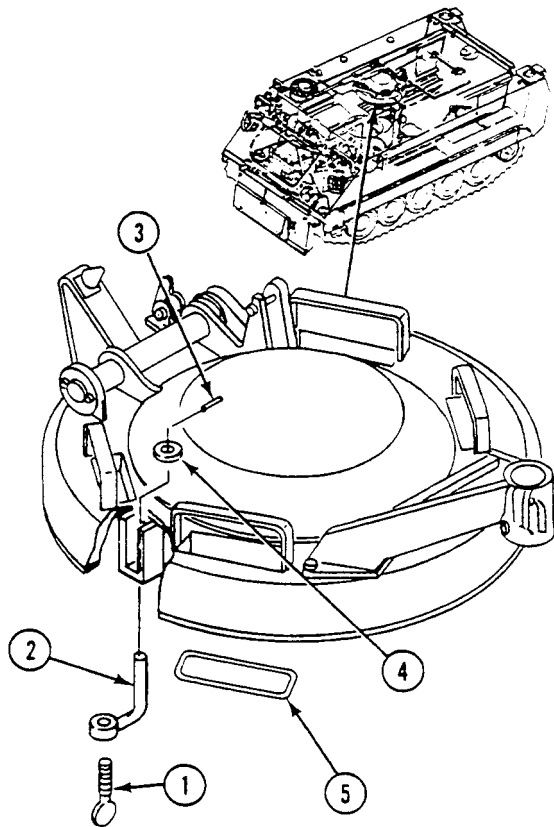
**FOLLOW-THROUGH STEPS**

1. Install vision block (see your -10).

END OF TASK

**REPLACE COMMANDER'S CUPOLA VISION BLOCK LOCKS AND SEALS
(M1064A3 ONLY)**

0491 00

THIS WORK PACKAGE COVERS:

Removal (page 0491 00-1).
Installation (page 0491 00-3).

INITIAL SETUP:

Maintenance Level

Unit

Personnel Required

Unit Mechanic

Tools and Special Tools

General Mechanic's Tool Kit (WP 0926 00, Item 65)
Socket Wrench Set (WP 0926 00, Item 72)
Torque Wrench (WP 0926 00, Item 80)
Torque Wrench (WP 0926 00, Item 84)

References

See your -10

Equipment Condition

Engine stopped (see your -10)
Carrier blocked (see your -10)
Vision block removed (see your -10)

Materials/Parts

Adhesive WP 0928 00, Item 4
Seal

REMOVAL

NOTE

**There are five vision blocks on the commander's cupola. Each block has two locks and one seal.
Task is for one lock and one seal.**

REPLACE COMMANDER'S CUPOLA VISION BLOCK LOCKS AND SEALS (M1064A3 ONLY) — Continued

0491 00

1. Remove thumbscrew (1) and spring (2) from periscope clamp (3).
2. Remove bolt (4), washer (5), and periscope clamp (3) from post (6).
3. Remove post (6) and washer (7) from cupola.
4. Scrape seal (8) from vision block opening.

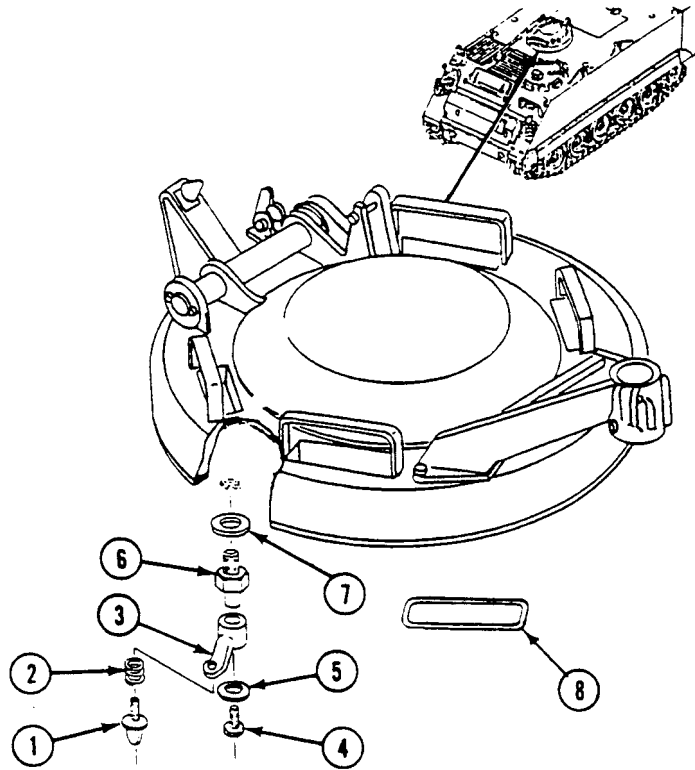

REPLACE COMMANDER'S CUPOLA VISION BLOCK LOCKS AND SEALS (M1064A3 ONLY) — Continued

0491 00

INSTALLATION**NOTE**

Surface on seal marked BOND THIS SIDE should be glued to cupola.

1. Apply adhesive to cleaned mating surface around vision block opening. Allow adhesive to become tacky. Install new seal (8) on cupola.
2. Install washer (7) and post (6) in cupola. **TIGHTEN POST TO 54-59 LB-FT (73-80 N·m) TORQUE.**
3. Install periscope clamp (3) on post (6). Secure with washer (5) and bolt (4). **TIGHTEN BOLT TO 144-168 LB-IN (16-19 N·m) TORQUE.**
4. Install spring (2) and thumbscrew (1) on periscope clamp (3). Deform first thread of thumbscrew to prevent easy removal.

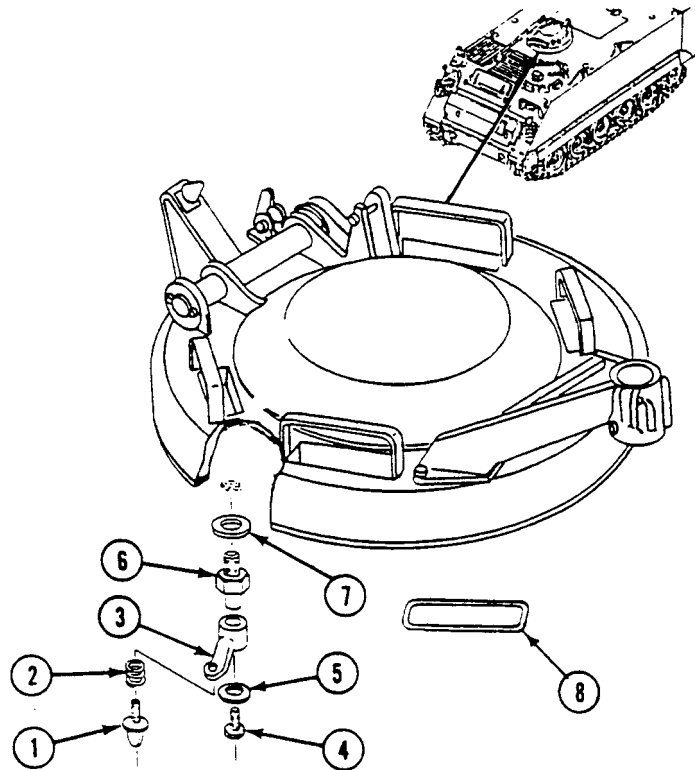
**FOLLOW-THROUGH STEPS**

1. Install vision block (see your -10).

END OF TASK

REPLACE COMMANDER'S CUPOLA BRAKE ASSEMBLY (M113A3, M1059A3, M58, AND M1064A3 ONLY)

0492 00

THIS WORK PACKAGE COVERS:

Removal (page 0492 00-1).
 Installation (page 0492 00-1).

INITIAL SETUP:Maintenance Level

Unit

References

See your -10

Tools and Special Tools

General Mechanic's Tool Kit (WP 0926 00, Item 65)

Equipment Condition

Engine stopped (see your -10)

Personnel Required

Unit Mechanic

Carrier blocked (see your -10)

REMOVAL

1. Remove two screws (1), washers (2), and brake assembly (3) from commander's cupola.

INSTALLATION

1. Align brake assembly (3) with holes in commander's cupola. Secure with two washers (2) and screws (1).

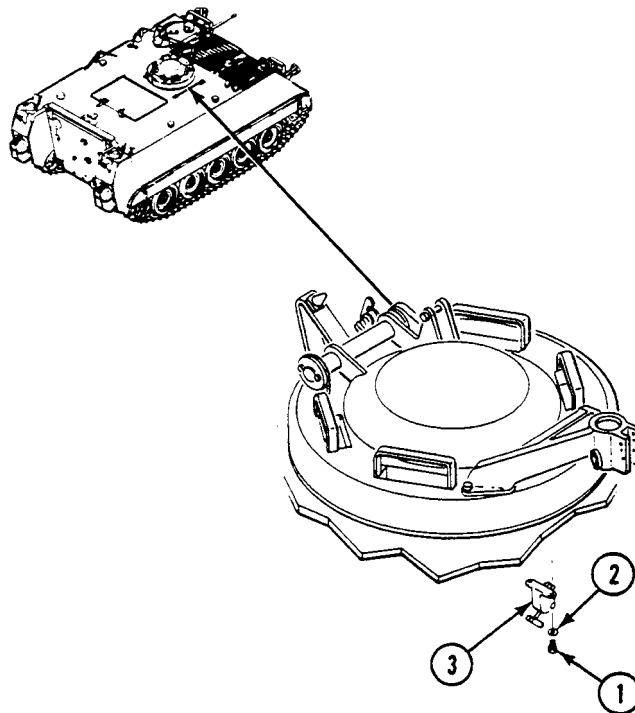
**FOLLOW-THROUGH STEPS**

1. Tighten brake. Check that brake can slow and stop cupola movement (see your -10).

END OF TASK

**REPLACE COMMANDER'S CUPOLA COVER (M113A3, M1059A3, M58,
AND M1064A3 ONLY)**

0493 00

THIS WORK PACKAGE COVERS:

Removal (page 0493 00-2).
Installation (page 0493 00-3).

INITIAL SETUP:

Maintenance Level

Unit

Personnel Required

Unit Mechanic

Tools and Special Tools

General Mechanic's Tool Kit (WP 0926 00, Item 65)

References

See your -10

Materials/Parts

Grease (WP 0928 00, Item 12)
Locknut (3)
Seal

Equipment Condition

Engine stopped (see your -10)
Carrier blocked (see your -10)

REMOVAL

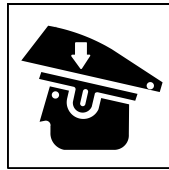
WARNING

Falling hatch could seriously injure you.

Keep head lower than closed hatch position when opening or closing hatch. Keep hands clear of hatch rim when closing. Make sure latch pin or mechanism is fully engaged when hatch is in any open position.

1. Remove two locknuts (1), washers (2), screws (3), and retainer (4) from cupola bracket. Discard locknuts.
2. Support cover (5). Remove 12 springs (6), shield (7), two fiber washers (8), and cover (5) from cupola.
3. Remove locknut (9) and screw (10) from cover (5). Discard locknut.
4. Pry up end of seal (11) and remove from cover (5). Discard seal.

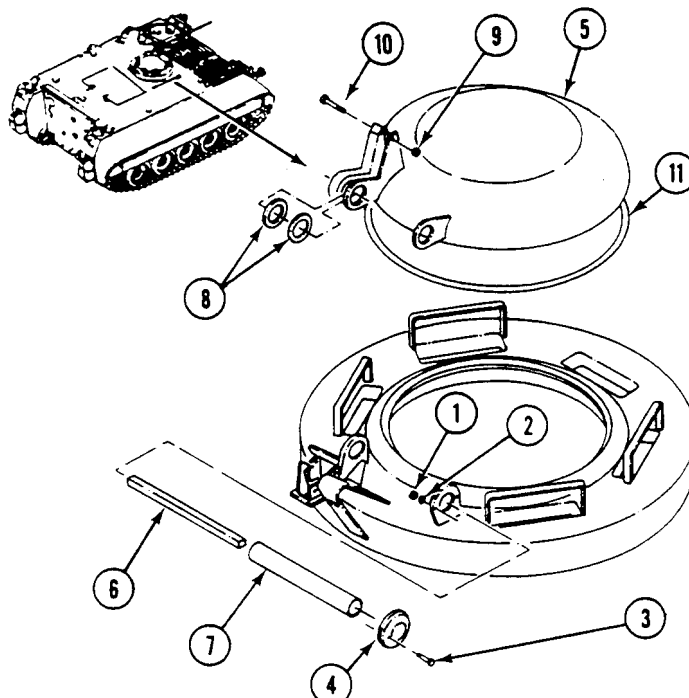

REPLACE COMMANDER'S CUPOLA COVER (M113A3, M1059A3, M58, AND M1064A3 ONLY) — Continued

0493 00

INSTALLATION

1. Place new seal (11) over retaining groove in cover (5). Press seal into place. Trim end of seal if needed.
2. Install screw (10) in cover (5). Secure with new locknut (9).
3. Align cover (5) with cupola brackets. Install two fiber washers (8) and shield (7).
4. Apply light coat of grease to each spring (6). Install 12 springs in shield (7).
5. Place cover (5) in vertical position. Install retainer (4) on cupola bracket. Secure with two screws (3), washers (2), and new locknuts (1).

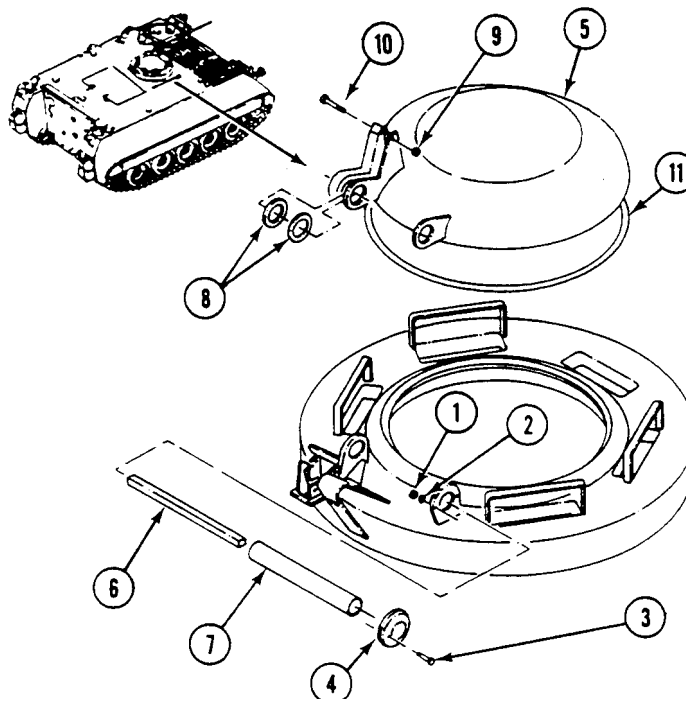
**FOLLOW-THROUGH STEPS**

1. Adjust commander's cupola cover latch (WP 0496 00).
2. Close cover. Check that commander's cupola cover is installed right (see your -10).

END OF TASK

**REPLACE COMMANDER'S CUPOLA HOLD-OPEN HOOK AND BUMPER
(M113A3, M1059A3, M58, AND M1064A3 ONLY)**

0494 00

THIS WORK PACKAGE COVERS:

Removal (page 0494 00-1).
Installation (page 0494 00-2).

INITIAL SETUP:

Maintenance Level

Unit

References

See your -10

Tools and Special Tools

General Mechanic's Tool Kit (WP 0926 00, Item 65)

Equipment Condition

Engine stopped (see your -10)

Personnel Required

Unit Mechanic

Carrier blocked (see your -10)

REMOVAL

1. Open both ends of hook (1). Remove hook from chain (2) and cupola bracket.
2. Remove tube (3) from chain (2).
3. Open both ends of hook (4). Remove hook from chain (2) and safety pin (5).

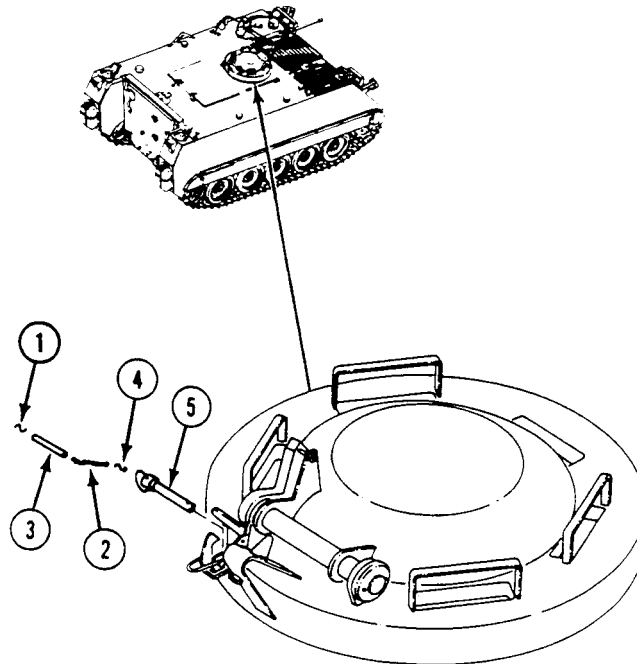

REPLACE COMMANDER'S CUPOLA HOLD-OPEN HOOK AND BUMPER (M113A3, M1059A3, M58, AND M1064A3 ONLY) — Continued

0494 00

4. Remove locknut (6), two washers (7), spring (8), two spacers (9), hook (10), and screw (11) from cupola.
5. Remove nut (12), washer (13), bumper (14), and washer(s) (15) from cupola bracket.

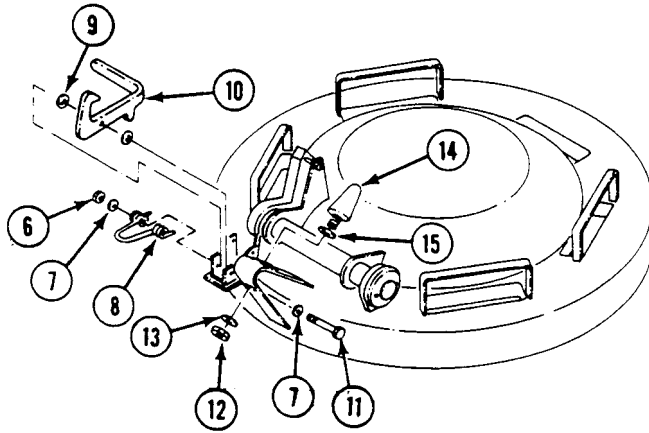
**INSTALLATION****NOTE**

Install washer(s), as needed, to compress bumper 1/4 inch (6 mm) when hold-open hook is engaged.

1. Install washer(s) (15) and bumper (14) in cupola bracket. Secure with washer (13) and nut (12).
2. Align hook (10), two spacers (9), spring (8), and two washers (7) with cupola bracket. Secure with screw (11) and locknut (6).

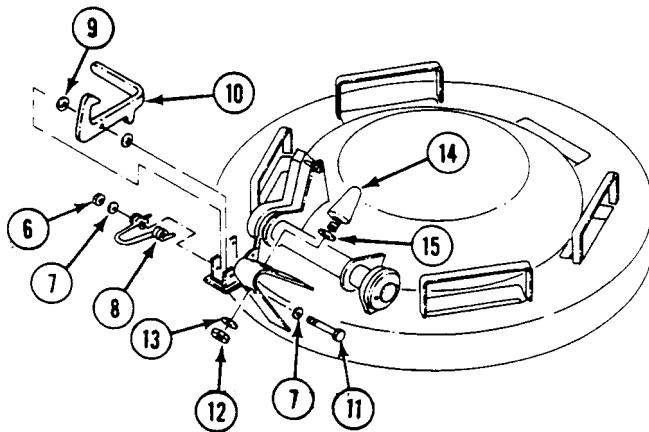

**REPLACE COMMANDER'S CUPOLA HOLD-OPEN HOOK AND BUMPER (M113A3,
M1059A3, M58, AND M1064A3 ONLY) — Continued**

0494 00

3. Install hook (1) in safety pin (2) and chain (3). Squeeze both ends of hook to secure.
4. Install tube (4) on chain (3).
5. Install hook (5) in chain (3) and cupola bracket. Squeeze both ends of hook to secure.

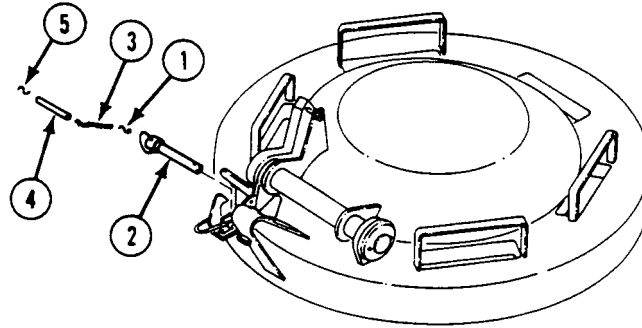
**FOLLOW-THROUGH STEPS**

1. Open commander's cupola cover and engage hook (see your -10). Check that hook and bumper are installed right.

END OF TASK

**REPLACE COMMANDER'S CUPOLA SAFETY PIN STOWAGE BLOCK
(M113A3, M1059A3, M58, AND M1064A3 ONLY)**

0495 00

THIS WORK PACKAGE COVERS:

Removal (page 0495 00-1).
Installation (page 0495 00-1).

INITIAL SETUP:

Maintenance Level

Unit

References

See your -10

Tools and Special Tools

General Mechanic's Tool Kit (WP 0926 00, Item 65)

Equipment Condition

Engine stopped (see your -10)

Materials/Parts

Locknut (2)

Carrier blocked (see your -10)

Personnel Required

Unit Mechanic

Commander's hatch closed and latched (see your -10)

REMOVAL

1. Remove two screws (1), locknuts (2), four washers (3), and block (4) from cupola. Discard locknuts.

INSTALLATION

1. Install block (4) on cupola and secure with two screws (1), new locknuts (2), and four washers (3).

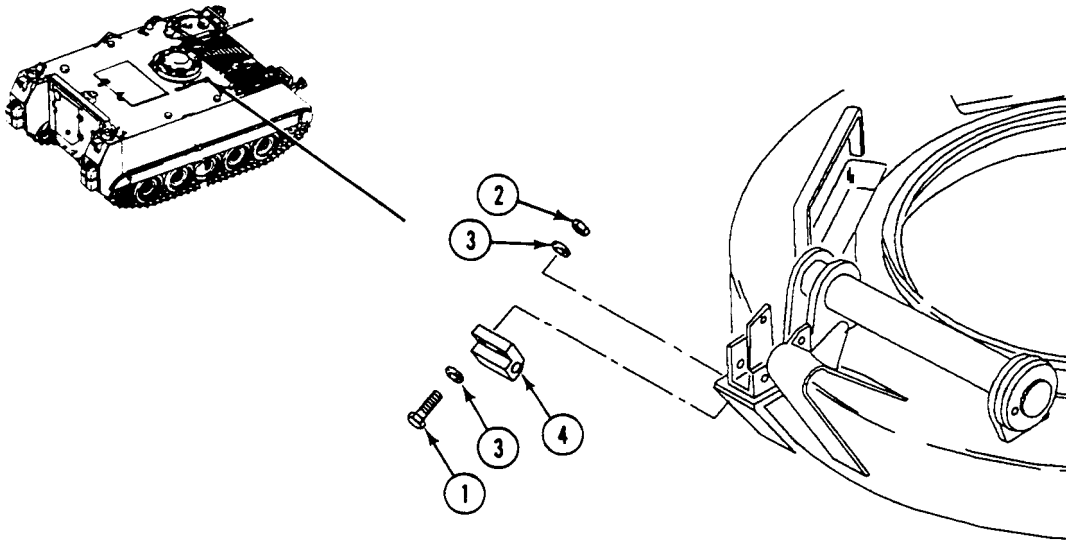

END OF TASK

REPLACE COMMANDER'S CUPOLA INTERIOR LATCH (M113A3, M1059A3, M58, AND M1064A3 ONLY)

0496 00

THIS WORK PACKAGE COVERS:

- Removal (page 0496 00-1).
- Installation (page 0496 00-2).
- Adjustment (page 0496 00-2).

INITIAL SETUP:

Maintenance Level

Unit

Personnel Required

Unit Mechanic

Tools and Special Tools

- General Mechanic's Tool Kit (WP 0926 00, Item 65)
- Socket Wrench Set (WP 0926 00, Item 72)
- Torque Wrench (WP 0926 00, Item 81)

References

See your -10

Materials/Parts

Cotter pin

Equipment Condition

- Engine stopped (see your -10)
- Carrier blocked (see your -10)

REMOVAL

1. Remove cotter pin (1) from headed pin (2). Discard cotter pin.
2. Remove pin (2), spring (3), and catch (4) from support (5).
3. Remove two screws (6), washers (7), support (5), and shim(s) (8) from cupola.
4. Remove two screws (9), washers (10), and striker (11) from cupola cover.

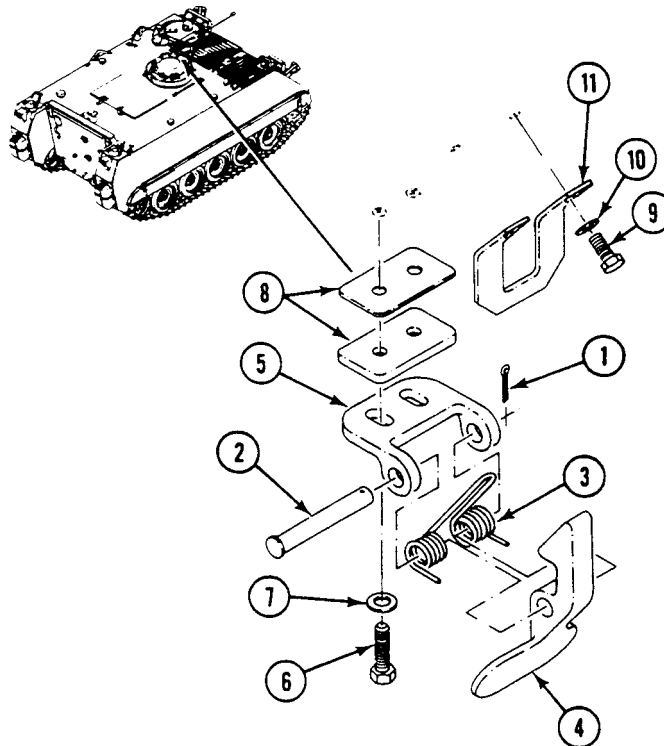

REPLACE COMMANDER'S CUPOLA INTERIOR LATCH (M113A3, M1059A3, M58, AND M1064A3 ONLY) — Continued

0496 00

INSTALLATION

1. Align striker (11) with holes in cupola cover. Secure with two washers (10) and screws (9).
2. Place shim(s) (8) and support (5) on cupola. Secure with two washers (7) and screws (6). Do not tighten screws until Step 3.
3. Align catch (4) and spring (3) with support (5). Secure with headed pin (2) and new cotter pin (1).

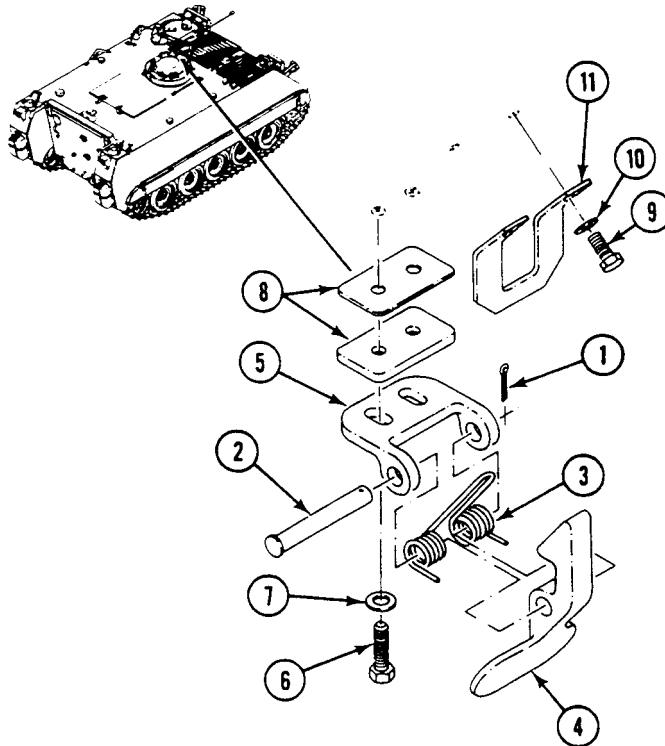
**ADJUSTMENT**

1. Open and close cupola cover. Check that cover latches tightly with a firm latching action.
2. To increase pressure of catch (4) on striker (11), add shim(s) (8) between support (5) and cupola. To decrease pressure, remove shim(s).
3. TIGHTEN TWO SCREWS (6) TO 300-360 LB-IN (34-41 N·m) TORQUE.

END OF TASK

REPLACE COMMANDER'S CUPOLA MACHINE GUN MOUNT (M113A3, M1059A3, M58, AND M1064A3 ONLY)

0497 00

THIS WORK PACKAGE COVERS:

Removal (page 0497 00-1).
 Installation (page 0497 00-1).

INITIAL SETUP:

Maintenance Level
 Unit

References
 See your -10

Tools and Special Tools
 General Mechanic's Tool Kit (WP 0926 00, Item 65)

Equipment Condition

Personnel Required
 Unit Mechanic

Engine stopped (see your -10)
 Carrier blocked (see your -10)

REMOVAL

NOTE

Spacers are used on M58 only.

Remove four screws (1), washers (2), and machine gun mount (3), and two spacers (4) from commander's cupola.

INSTALLATION

Place two spacers (4) and machine gun mount (3) on commander's cupola. Secure with four washers (2) and screws (1).

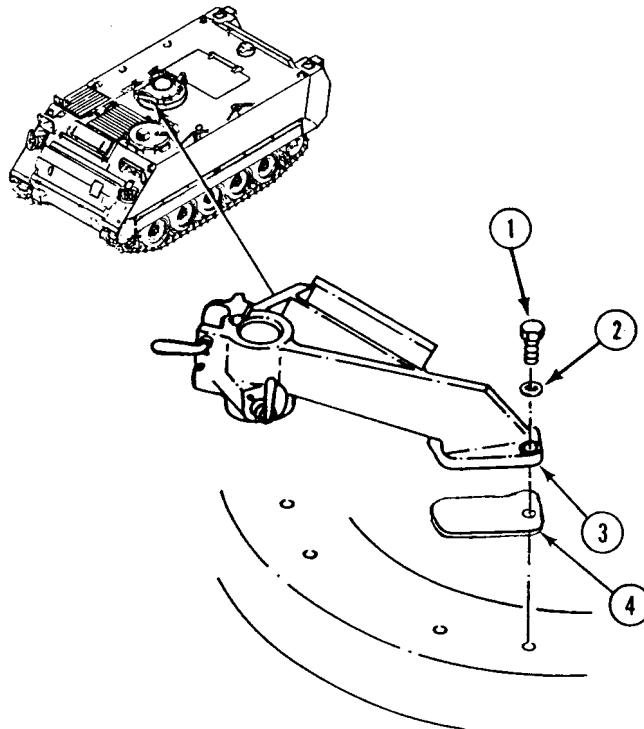

END OF TASK

REPAIR COMMANDER'S CUPOLA MACHINE GUN MOUNT (M113A3, M1059A3, M58, AND M1064A3 ONLY)

0498 00

THIS WORK PACKAGE COVERS:

Disassembly (page 0498 00-1).
 Assembly (page 0498 00-2).

INITIAL SETUP:

Maintenance Level

Unit

Personnel Required

Unit Mechanic

Tools and Special Tools

General Mechanic's Tool Kit (WP 0926 00, Item 65)

References

See your -10

Materials/Parts

Cotter pin (2)

Equipment Condition

Engine stopped (see your -10)
 Carrier blocked (see your -10)

DISASSEMBLY

1. Remove cotter pin (1) and pin (2) from mount (3). Discard cotter pin.
2. Remove travel lock pin (4), two S-hooks (5), chain (6), and travel lock (7) from mount (3).

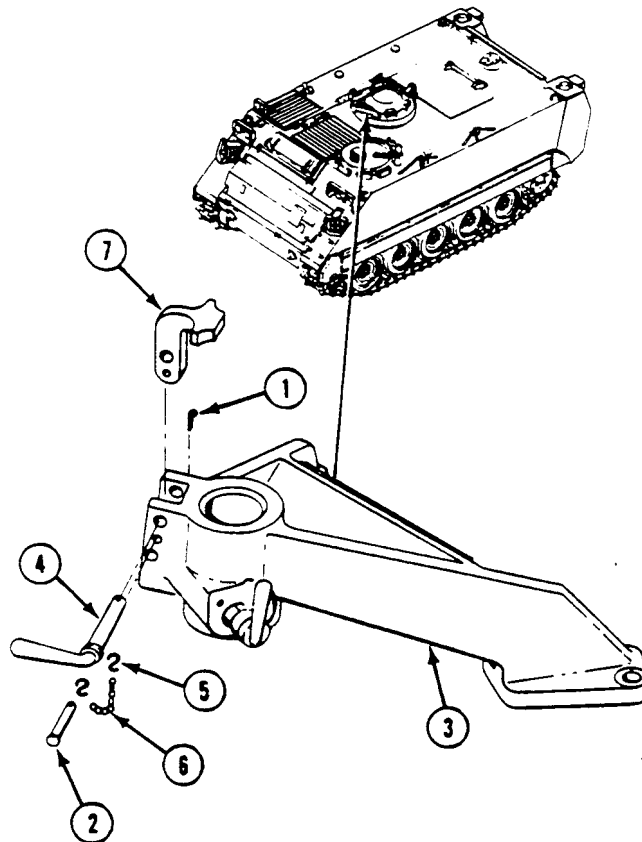

3. Remove cotter pin (8), cover (9), spring (10), and pin (11) from mount (3). Discard cotter pin.

REPAIR COMMANDER'S CUPOLA MACHINE GUN MOUNT (M113A3, M1059A3, M58,
AND M1064A3 ONLY) — Continued

0498 00

4. Remove cam and handle assembly (12) and two pins (13) from mount (3).
5. Remove two screws (14), washers (15), and stop (16) from mount (3).

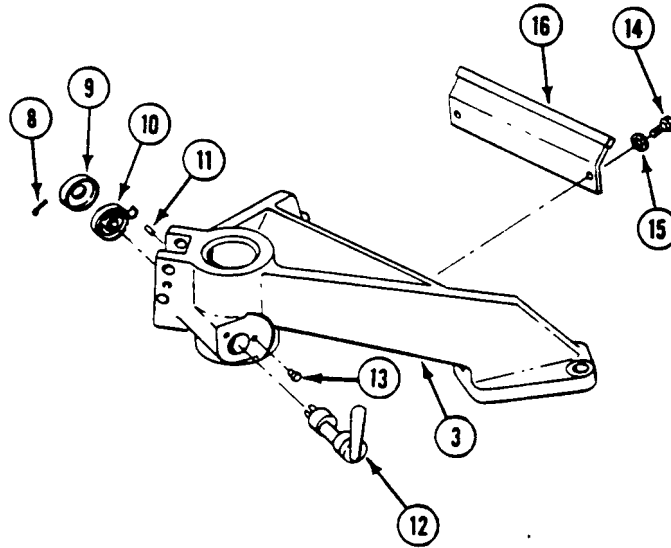

ASSEMBLY

1. Install stop (1) on mount (2). Secure with two washers (3) and screws (4).
2. Install cam and handle assembly (5) and two pins (6) in mount (2).
3. Install pin (7) in mount (2). Install spring (8) with center tang engaging slot in handle (5) and outer tang engaging pin (7).
4. Install cover (9) over spring (8). Secure with new cotter pin (10) through handle (5).

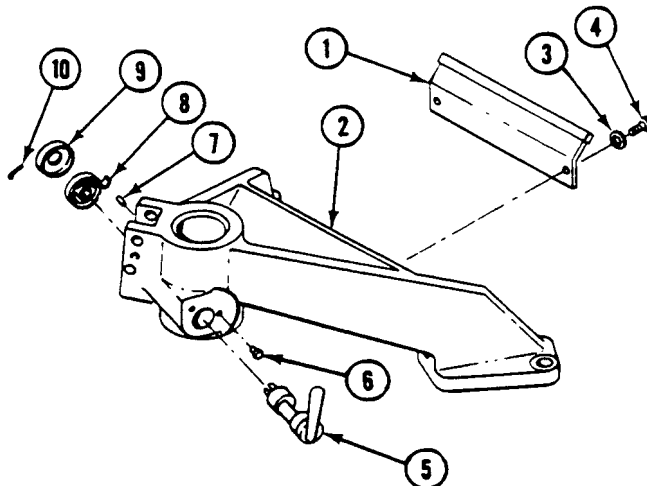

**REPAIR COMMANDER'S CUPOLA MACHINE GUN MOUNT (M113A3, M1059A3, M58,
AND M1064A3 ONLY) — Continued**

0498 00

5. Install travel lock (11) in mount (2).
6. Insert lock pin (12) through mount (2) and large hole in travel lock (11).
7. Install pin (13) through travel lock (11). Secure with new cotter pin (14).
8. Install two S-hooks (15) and chain (16) between pin (13) and lock pin (12).

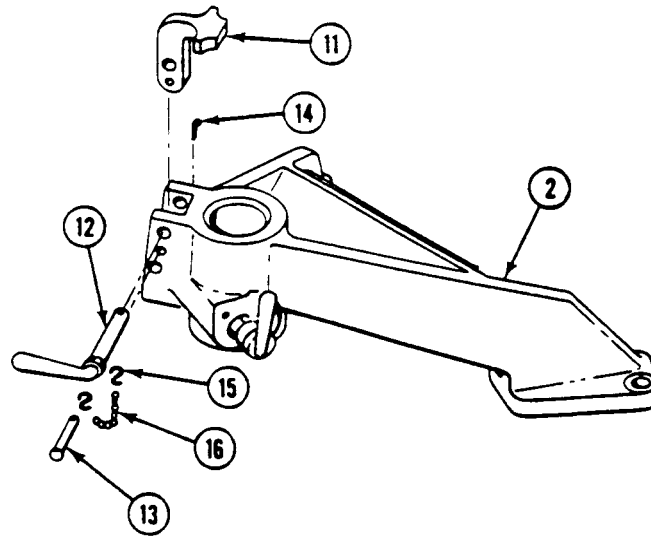
**END OF TASK**

**REPLACE COMMANDER'S CUPOLA MACHINE GUN MOUNT STOPS
(M1059A3 ONLY)**

0499 00

THIS WORK PACKAGE COVERS:

Removal (page 0499 00-1).
Installation (page 0499 00-3).

INITIAL SETUP:

Maintenance Level

Unit

Personnel Required

Unit Mechanic

Tools and Special Tools

General Mechanic's Tool Kit (WP 0926 00, Item 65)
Socket Wrench Set (WP 0926 00, Item 72)
Torque Wrench (WP 0926 00, Item 81)

References

See your -10

Materials/Parts

Lockwasher (4)

Equipment Condition

Engine stopped (see your -10)
Carrier blocked (see your -10)

REMOVAL

NOTE

Left and right stops (brackets) are removed and installed the same way.

**REPLACE COMMANDER'S CUPOLA MACHINE GUN MOUNT STOPS (M1059A3 ONLY) —
Continued**

0499 00

1. Remove two screws (1), lockwashers (2), washers (3) bracket (4) and shims (5) from carrier. Discard lockwashers.
2. Remove two screws (6), lockwashers (7), and catch (8) from mount (9). Discard lockwasher.

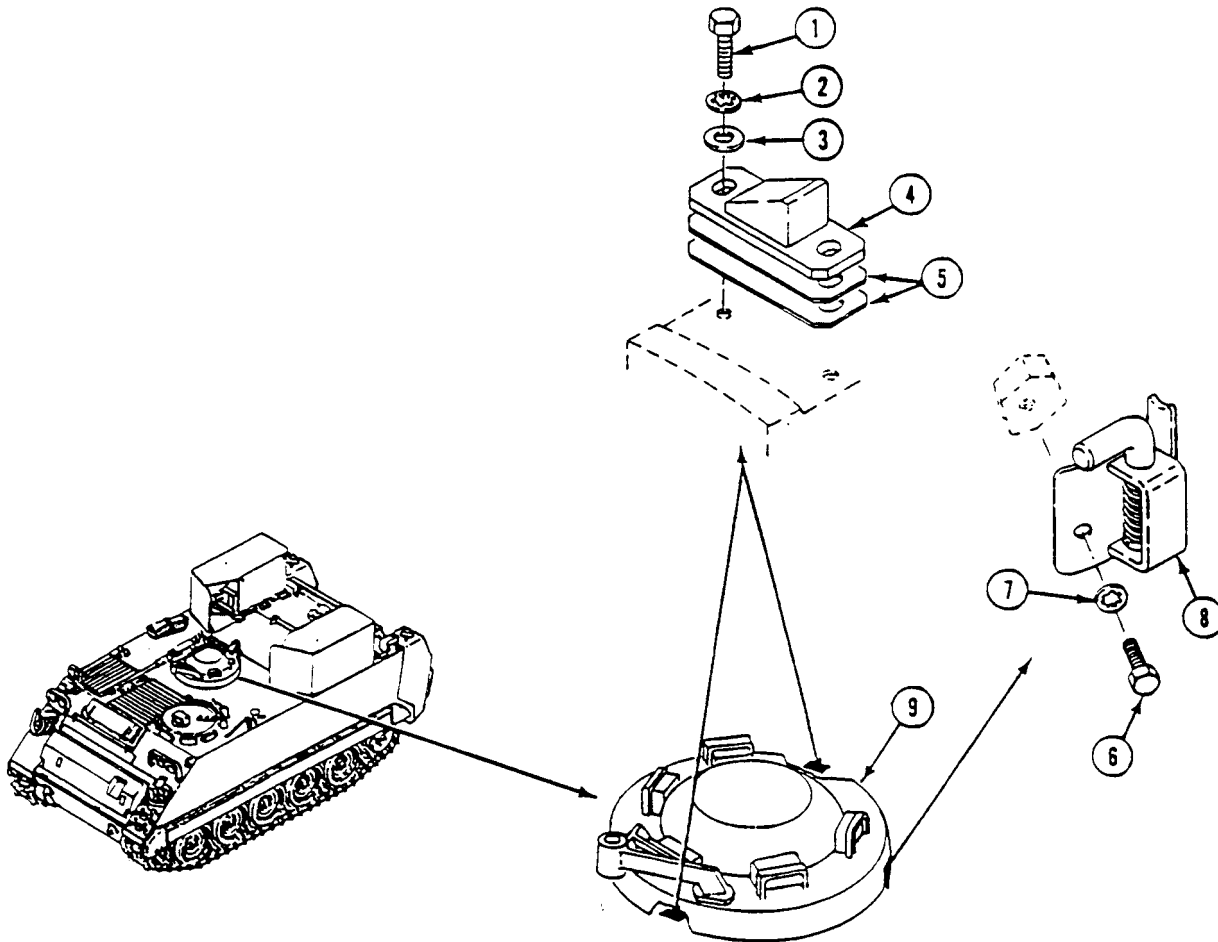

REPLACE COMMANDER'S CUPOLA MACHINE GUN MOUNT STOPS (M1059A3 ONLY) —
Continued

0499 00

INSTALLATION

1. Install catch (1) on mount (2). Secure with two new lockwashers (3) and screws (4). TIGHTEN SCREWS TO 264-284 IN-LB (30-32 N·m) TORQUE.

NOTE

**Install shims (5) as required so pin of catch contacts bracket from 5/16 to 7/16 inch (8 to 11 mm).
 Make sure flat surface of bracket makes contact with pin.**

2. Install shims (5) and bracket (6) on carrier. Secure with two washers (7), new lockwashers (8), and screws (9). TIGHTEN SCREWS TO 264-284 IN-LB (30-32 N·m)TORQUE.
3. Turn cupola until catch (1) contacts bracket (6). Measure distance from bottom of pin to top of bracket. Distance should be 5/16 to 7/16 inch (8 to 11 mm). If not, add or remove shims (5) to obtain correct measurement.

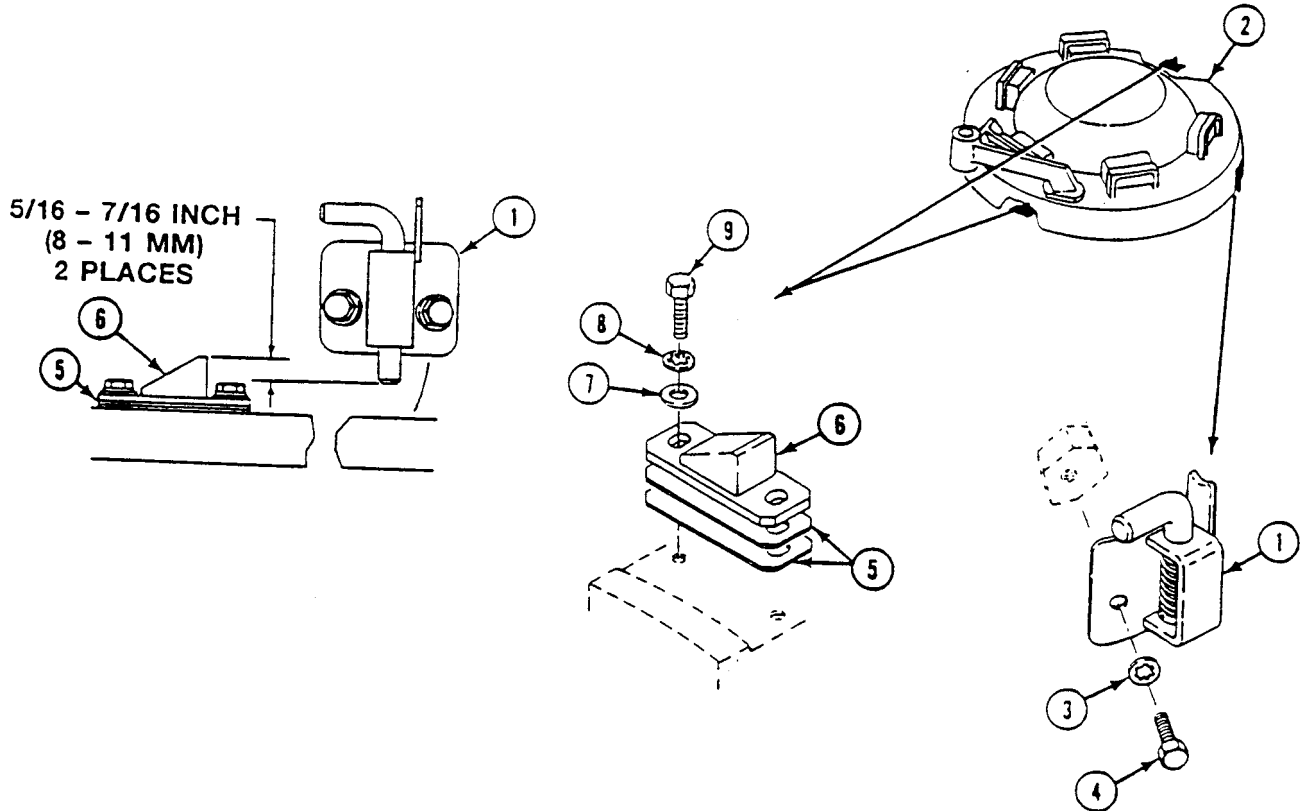

END OF TASK

**REPLACE COMMANDER'S HATCH CUSHIONING PAD AND HANDLE
(M577A3 AND M1068A3 ONLY)**

0500 00

THIS WORK PACKAGE COVERS:

Removal (page 0500 00-1).
Installation (page 0500 00-2).

INITIAL SETUP:

Maintenance Level

Unit

Personnel Required

Unit Mechanic

Tools and Special Tools

General Mechanic's Tool Kit (WP 0926 00, Item 65)

References

See your -10

Materials/Parts

Lockwasher (2)
Lockwasher (6)

Equipment Condition

Engine stopped (see your -10)
Carrier blocked (see your -10)

REMOVAL

1. Remove two screws (1), lockwashers (2), and handle (3) from hull ceiling. Discard lockwashers.
2. Remove six screws (4), lockwashers (5), washers (6), and pad (7) from commander's hatch opening. Discard lockwashers.

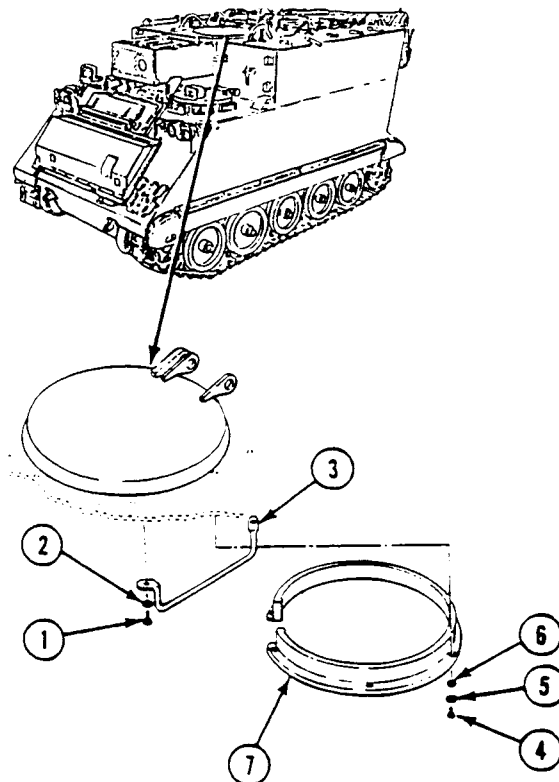

REPLACE COMMANDER'S HATCH CUSHIONING PAD AND HANDLE (M577A3 AND M1068A3 ONLY) — Continued

0500 00

CLEANING**CLEANING, INSPECTION, AND REPAIR**

1. Clean cushioning pad with soap and water. Dry with clean cloth.
2. Check handle. Replace cracked or damaged handle.
3. Check pad. Replace cut, broken, or hard pad.

INSTALLATION

1. Install pad (7) in commander's hatch opening. Secure with six washers (6), new lockwashers (5), and screws (4).
2. Place handle (3) on hull ceiling. Secure with two new lockwashers (2) and screws (1).

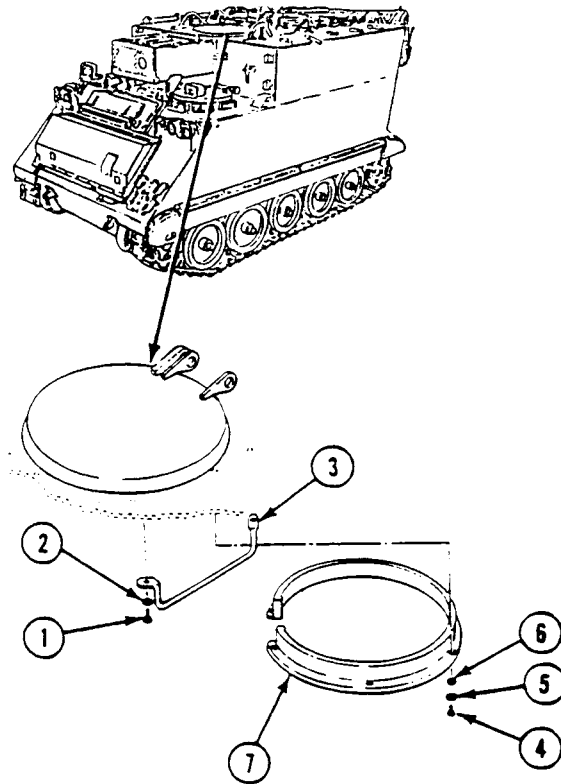
**END OF TASK**

REPLACE COMMANDER'S HATCH HOOK AND BUMPER (M577A3 AND M1068A3 ONLY)

0501 00

THIS WORK PACKAGE COVERS:

Removal (page 0501 00-2).
 Installation (page 0501 00-4).

INITIAL SETUP:

Maintenance Level

Unit

Personnel Required

Unit Mechanic 63T10

Tools and Special Tools

General Mechanic's Tool Kit (WP 0926 00, Item 65)

References

See your -10

Materials/Parts

Locknut
 Locknut

Equipment Condition

Engine stopped (see your -10)
 Carrier blocked (see your -10)

— Continued

REMOVAL

WARNING



Falling hatch could seriously injure you.

Keep head lower than closed hatch position when opening or closing hatch. Keep hands clear of hatch rim when closing. Make sure latch pin or mechanism is fully engaged when hatch is in any open position.

1. Open both ends of hook (1). Remove from chain (2) and hull bracket.
2. Remove tube (3) from chain (2).
3. Open both ends of hook (4). Remove from chain (2) and quick release pin (5).
4. Remove two screws (6), nuts (7), four washers (8), and block (9) from bracket.
5. Remove locknut (10), washer (11), bumper (12), and washer (13) from hull brackets. Discard locknut.

REPLACE COMMANDER'S HATCH HOOK AND BUMPER (M577A3 AND M1068A3 ONLY)

0501 00

— Continued

6. Remove locknut (14), screw (15), two washers (16), spring (17), two spacers (18), and hook (19) from hull brackets. Discard locknut.

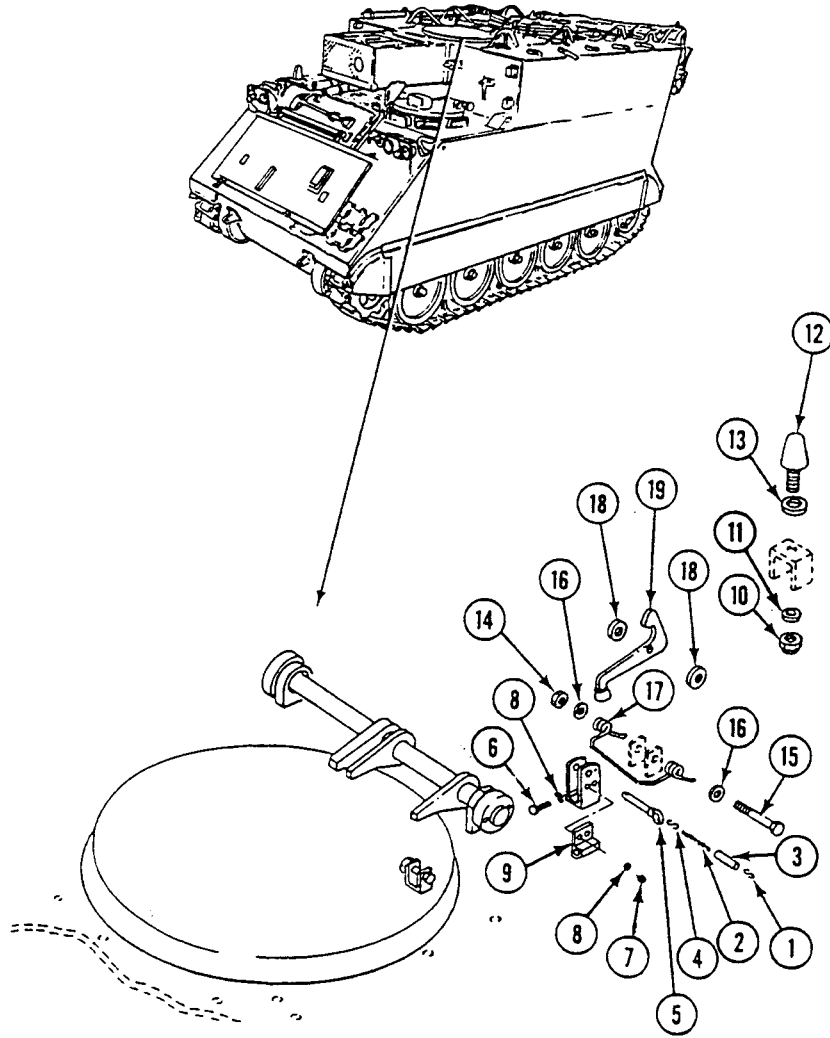

REPLACE COMMANDER'S HATCH HOOK AND BUMPER (M577A3 AND M1068A3 ONLY)**0501 00****— Continued****INSTALLATION**

1. Align hook (1), two spacers (2), spring (3), and two washers (4) with hull brackets. Secure with screw (5) and new locknut (6).

NOTE

Install washers (7), as needed, to compress bumper 1/4 inch (6 mm) when hook is engaged.

2. Install washer (7) and bumper (8) in hull bracket. Secure with washer (9) and new locknut (10).
3. Install block (11) four washers (12), two screws (13), and nuts (14) on bracket.
4. Install hook (15) in quick release pin (16) and chain (17). Squeeze both ends of hook to secure.
5. Install tube (18) on chain (17).
6. Install hook (19) on chain (17) and hull bracket. Squeeze both ends of hook to secure.

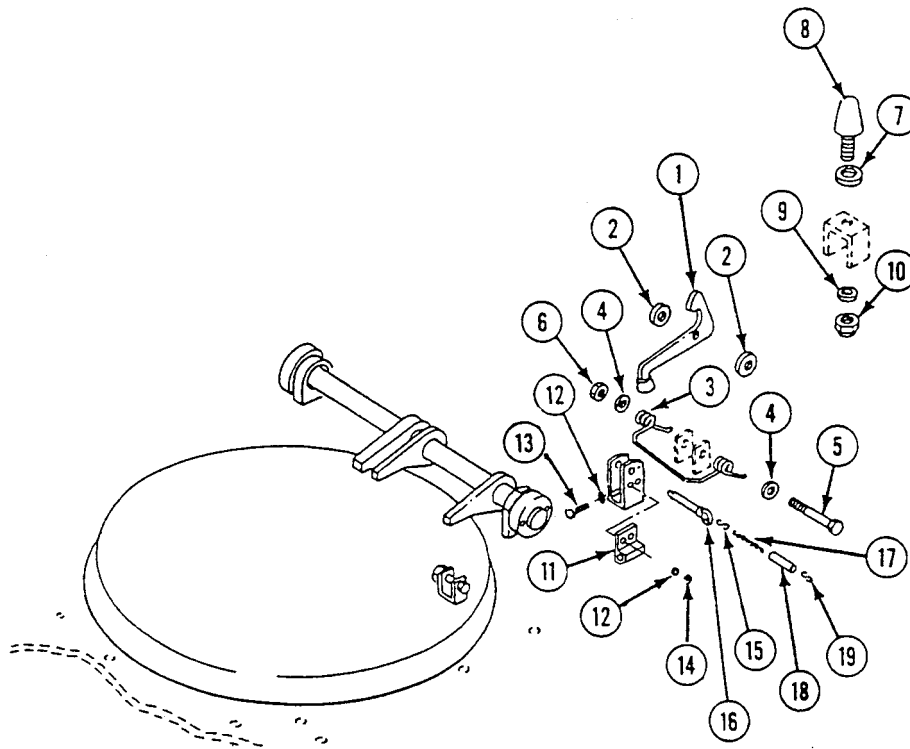
**FOLLOW-THROUGH STEPS**

1. Install and adjust commander's hatch interior latch WP 0502 00.
2. Open commander's hatch cover and engage hook (see your -10). Check that hook and bumper are properly installed.

END OF TASK

REPLACE COMMANDER'S HATCH INTERIOR LATCH (M577A3 AND M1068A3 ONLY)

0502 00

THIS WORK PACKAGE COVERS:

- Removal (page 0502 00-1).
- Installation (page 0502 00-2).
- Adjustment (page 0502 00-2).

INITIAL SETUP:

Maintenance Level

Unit

Personnel Required

Unit Mechanic

Tools and Special Tools

- General Mechanic's Tool Kit (WP 0926 00, Item 65)
- Socket Wrench Set (WP 0926 00, Item 72)
- Torque Wrench (WP 0926 00, Item 81)

References

See your -10

Materials/Parts

- Cotter pin
- Lockwasher (2)

Equipment Condition

- Engine stopped (see your -10)
- Carrier blocked (see your -10)

REMOVAL

1. Remove cotter pin (1) from headed pin (2). Discard cotter pin.
2. Remove pin (2), spring (3), and latch plate (4) from eye bracket (5).
3. Remove two screws (6), washers (7), eye bracket (5), and spacers (8) from hull.
4. Remove two screws (9), lockwashers (10), and strike (11) from commander's hatch cover. Discard lockwashers.

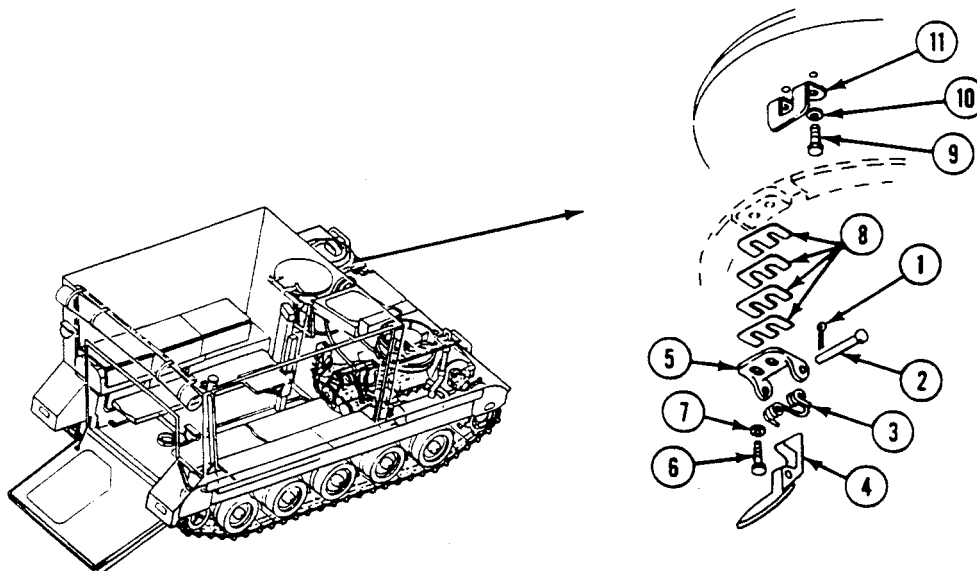

REPLACE COMMANDER'S HATCH INTERIOR LATCH (M577A3 AND M1068A3 ONLY) —
Continued

0502 00

INSTALLATION

1. Align strike (11) with holes in hatch cover. Secure with two new lockwashers (10) and screws (9).
2. Place spacers (8) and eye bracket (5) on hull. Secure with two washers (7) and screws (6). Do not tighten screws.
3. Align latch plate (4) and spring (3) with eye bracket (5). Secure with headed pin (2) and new cotter pin (1).

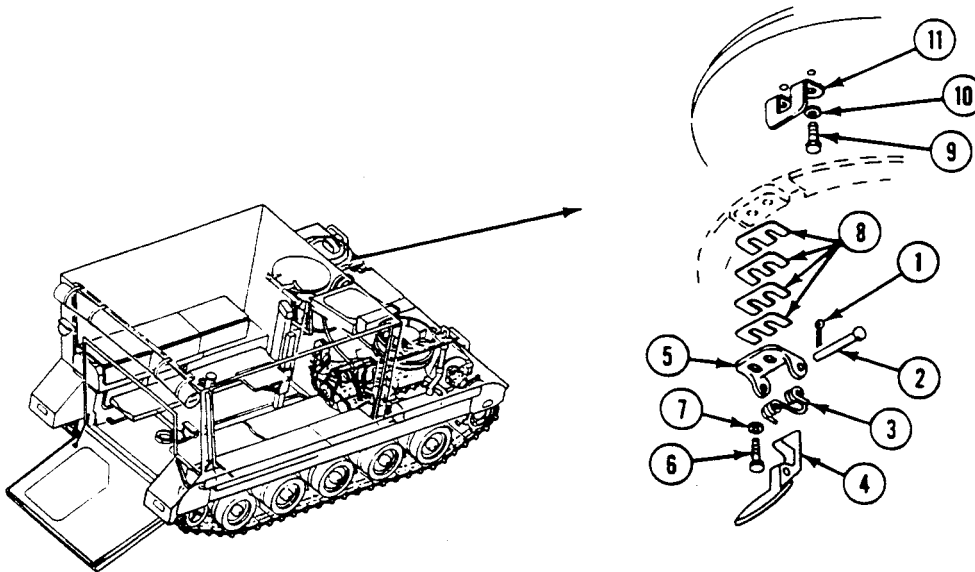
**ADJUSTMENT**

1. Check that commander's hatch cover latches tightly with a firm latching action.
2. To increase pressure of latch plate (4) on strike (11), add spacers (8) between eye bracket (5) and hull. To decrease pressure, use fewer spacers.
3. Tighten screws (6) to 300-360 lb-in (34-41 N.m) torque.

END OF TASK

REPLACE COMMANDER'S HATCH COVER (M577A3 AND M1068A3 ONLY)

0503 00

THIS WORK PACKAGE COVERS:

Removal (page 0503 00-2).
 Installation (page 0503 00-3).

INITIAL SETUP:

Maintenance Level

Unit

Personnel Required

Unit Mechanic

Tools and Special Tools

General Mechanic's Tool Kit (WP 0926 00, Item 65)

References

See your -10

Materials/Parts

Grease (WP 0928 00, Item 12)
 Locknut (4)
 Locknut

Equipment Condition

Engine stopped (see your -10)
 Carrier blocked (see your -10)
 Commander's hatch interior latch removed WP 0502 00

REMOVAL

WARNING



Driver's hatch cover may spring up and injure you. Open and support hatch cover in vertical position.

1. Remove four locknuts (1), screws (2), and two retaining plates (3) from hatch brackets. Discard locknuts.
2. Support hatch cover (4). Remove 28 springs (5), two tubes (6), spacers (7), and cover (4) from hatch brackets.
3. Remove locknut (8) and screw (9) from cover (4). Discard locknut.
4. If necessary, pry up end of seal (10) and remove from cover (4).

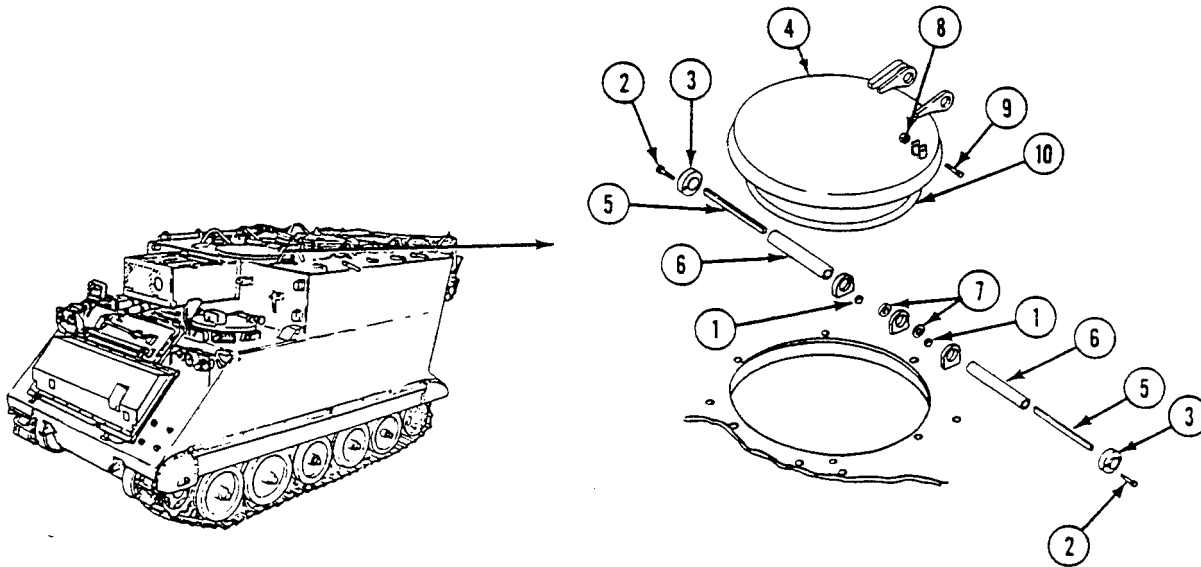

INSTALLATION

1. If removed, place seal (1) over retaining groove on cover (2). Press seal into place. Trim end of seal, if necessary.
2. Install screw (3) in cover (2). Secure with new locknut (4).
3. Align cover (2) with hinge brackets. Install two spacers (5) and tubes (6).
4. Apply a light coat of grease on each spring (7). Install 14 springs in each tube (6).
5. Place cover (2) in vertical position. Install two retaining plates (8) on hatch brackets. Secure with four screws (9) and new locknuts (10).

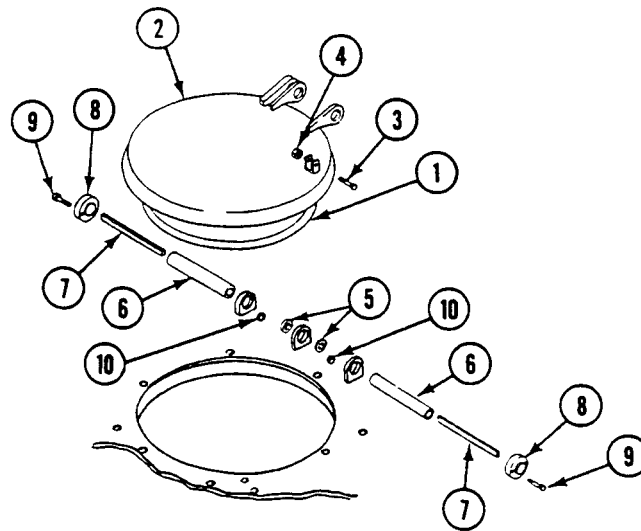
**FOLLOW-THROUGH STEPS**

1. Install and adjust commander's hatch interior latch WP 0502 00.
2. Close cover and check for proper installation.

END OF TASK

REPLACE RIGHT SIDE SPALL LINERS (M113A3 ONLY)

0504 00

THIS WORK PACKAGE COVERS:

- Removal (page 0504 00-1).
- Installation (page 0504 00-4).

INITIAL SETUP:

Maintenance Level

Unit

References

See your -10

Tools and Special Tools

- General Mechanic's Tool Kit (WP 0926 00, Item 65)
- Torque Wrench (WP 0926 00, Item 85)

Equipment Condition

- Engine stopped (see your -10)
- Carrier blocked (see your -10)
- Ramp lowered (see your -10)
- Quick release pins and plates removed (WP 0506 00)

Personnel Required

- Unit Mechanic
 - Helper (H)
-

REMOVAL

1. Position four shields (1) to rear of carrier.
2. Remove 12 screws (2) and washers (3) from upper front track (4). Remove track from hull.

NOTE

If upper front track needs to be replaced, do Step 3.

3. Loosen screw (5), and slide stop assembly (6) off end of upper front track (4).
4. Remove five screws (7) and washers (8) from lower front track (9) and support (10).

REPLACE RIGHT SIDE SPALL LINERS (M113A3 ONLY) — Continued

0504 00

5. Remove five screws (11) and washers (12) from lower front track (9). Remove track from hull.
6. Slide four shields (1) forward and remove.

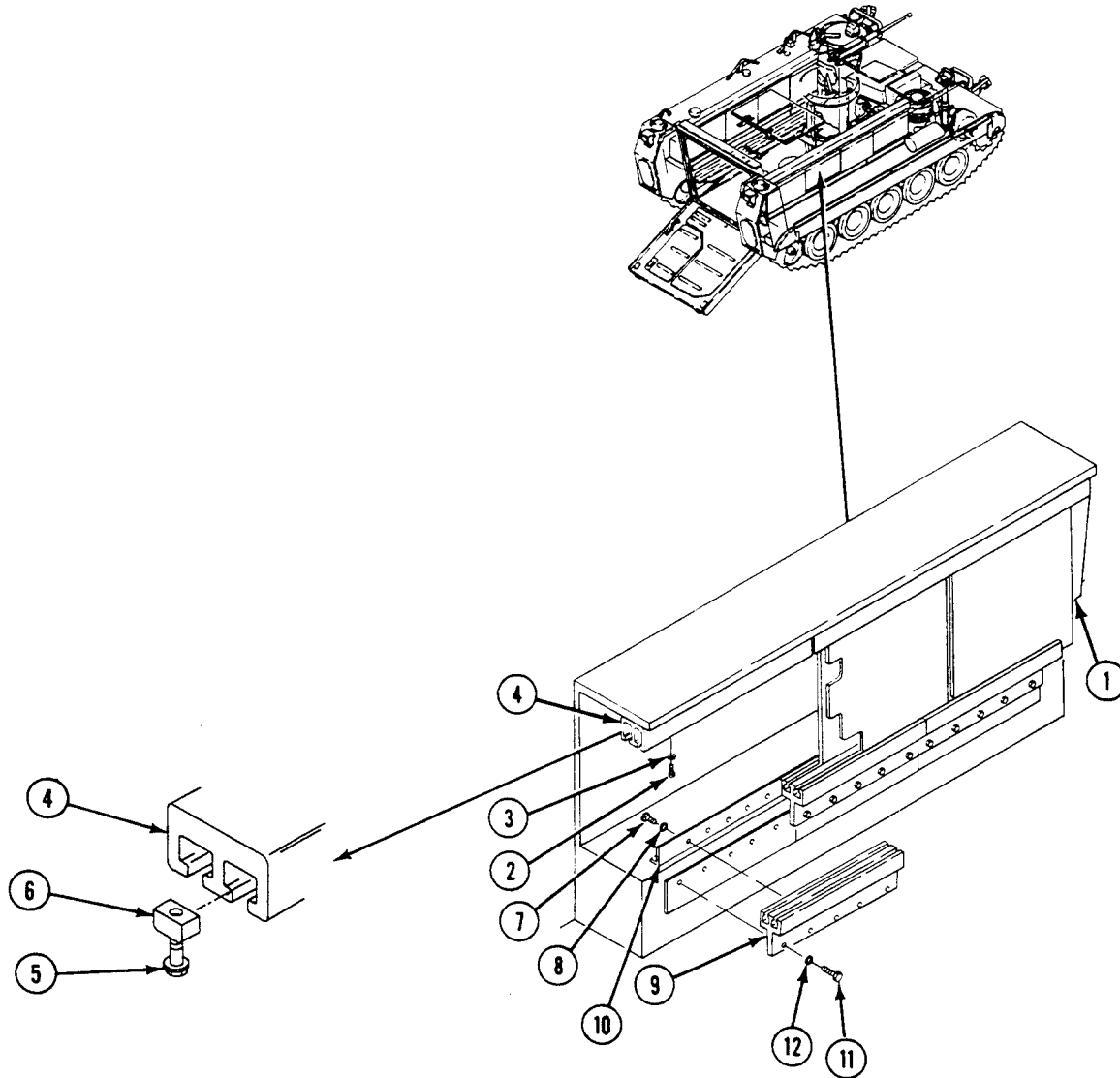

7. Remove 24 screws (1) and washers (2) from upper rear track (3). Remove track from hull. Have helper assist.

NOTE

If upper rear track needs to be replaced, do Step 8.

8. Loosen two screws (4), and slide two stop assemblies (5) off end of upper rear track (3).
9. Remove 10 screws (6) and washers (7) from middle lower track (8), rear lower track (9), and support (10).
10. Remove 10 screws (11) and washers (12) from middle lower track (8) and rear lower track (9). Remove tracks from hull.

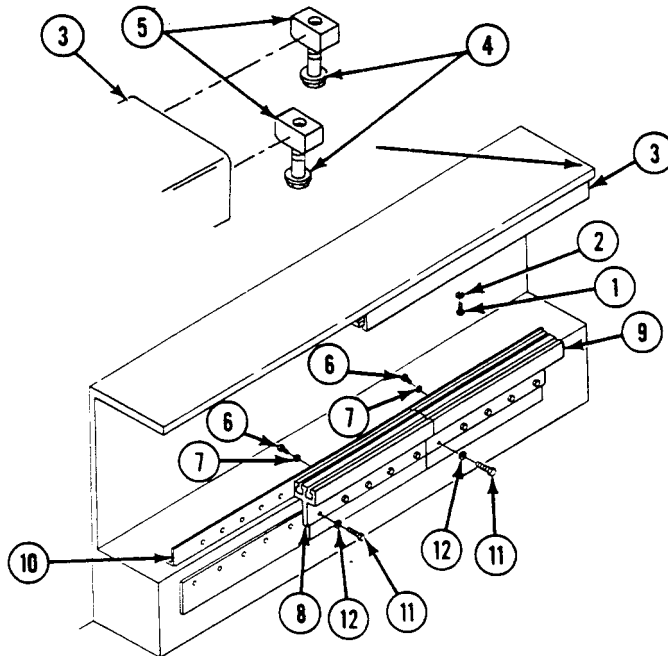

11. Remove 15 screws (13) and washers (14) from three supports (10). Remove supports from hull.

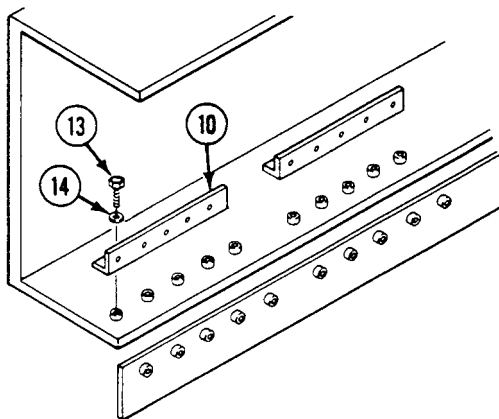

INSTALLATION

1. Install three supports (10) on hull. Secure with 15 screws (13) and washers (14). TIGHTEN SCREWS TO 32-34 LB-FT (43-46 N·m) TORQUE.

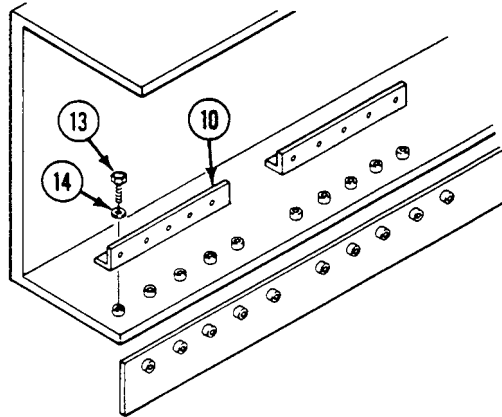

2. Install rear lower track (9) and middle lower track (8) on hull. Secure with 10 screws (11) and washers (12). TIGHTEN SCREWS TO 32-34 LB-FT (43-46 N·m) TORQUE.
3. Install rear lower track (9) and middle lower track (8) on support (10). Secure with 10 screws (6) and washers (7). TIGHTEN SCREWS TO 32-34 LB-FT (43-46 N·m) TORQUE.

NOTE

If stop assemblies were removed in Step 8, do Step 4 and Step 5.

4. Slide stop assembly (5) onto outside track of upper rear track (3). Position stop 4-3/4 to 3-3/4 inches (12.07 to 9.53 cm) from end of track. Secure stop with screw (4).
5. Slide other stop assembly (5) onto inside track of upper rear track (3). Position stop 7/16 to 3/8 inches (1.11 to 0.95 cm) from end of track. Secure stop with screw (4).
6. Install upper rear track (3) on hull. Secure with 24 screws (1) and washers (2). **TIGHTEN SCREWS TO 32-34 LB-FT (43-46 N·m) TORQUE.** Have helper assist.

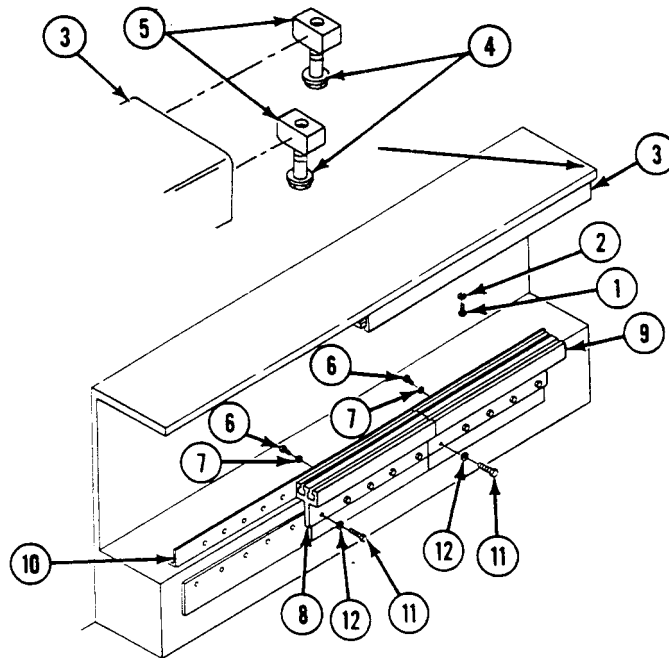
**NOTE**

Install rear shield on the right track first and alternate the other three shields. There should be two shields on each track.

7. Install four shields (1) and position them to the rear.
8. Install lower front track (2) on hull. Secure with five screws (3) and washers (4). **TIGHTEN SCREWS TO 32-34 LB-FT (43-46 N·m) TORQUE.**
9. Install lower front track (2) to support (5). Secure with five screws (6) and washers (7). **TIGHTEN SCREWS TO 32-34 LB-FT (43-46 N·m) TORQUE.**

NOTE

If stop assembly was removed in Step 3, do Step 10.

10. Slide stop assembly (8) onto inside track of upper front track. Position stop 4-5/16 to 4-13/16 inch (10.95 to 12.22 cm) from end of track. Secure stop with screw (9).
11. Install upper front track (10) on hull. Secure with 12 screws (11) and washers (12). **TIGHTEN SCREWS TO 32-34 LB-FT (43-46 N·m) TORQUE.**

12. Realign four shields (1) to overlap.

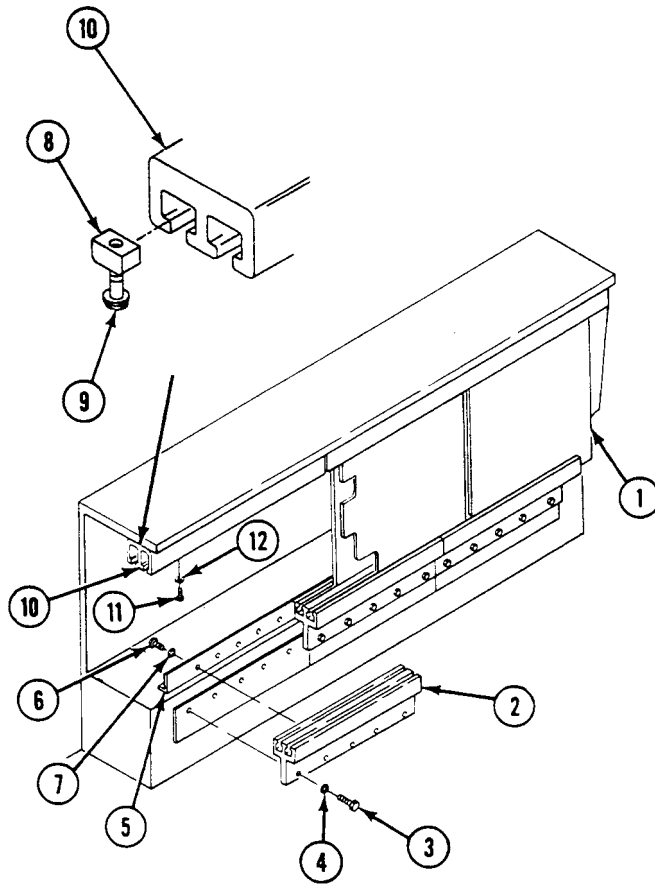

FOLLOW-THROUGH STEPS

1. Install quick release pins and plates (WP 0506 00).
2. Start engine (see your -10).
3. Raise and lock ramp (see your -10).
4. Stop engine (see your -10).

END OF TASK

REPLACE LEFT SIDE SPALL LINERS (M113A3 ONLY)

0505 00

THIS WORK PACKAGE COVERS:

- Removal (page 0505 00-1).
- Installation (page 0505 00-4).

INITIAL SETUP:

Maintenance Level

Unit

References

See your -10

Tools and Special Tools

- General Mechanic's Tool Kit (WP 0926 00, Item 65)
- Torque Wrench Adapter (WP 0926 00, Item 5)
- Torque Wrench (WP 0926 00, Item 85)

Equipment Condition

- Engine stopped (see your -10)
- Carrier blocked (see your -10)
- Ramp lowered (see your -10)
- Quick release pins and plates removed (WP 0506 00)

Personnel Required

- Unit Mechanic
- Helper (H)

REMOVAL

1. Position four shields (1) to rear of carrier.

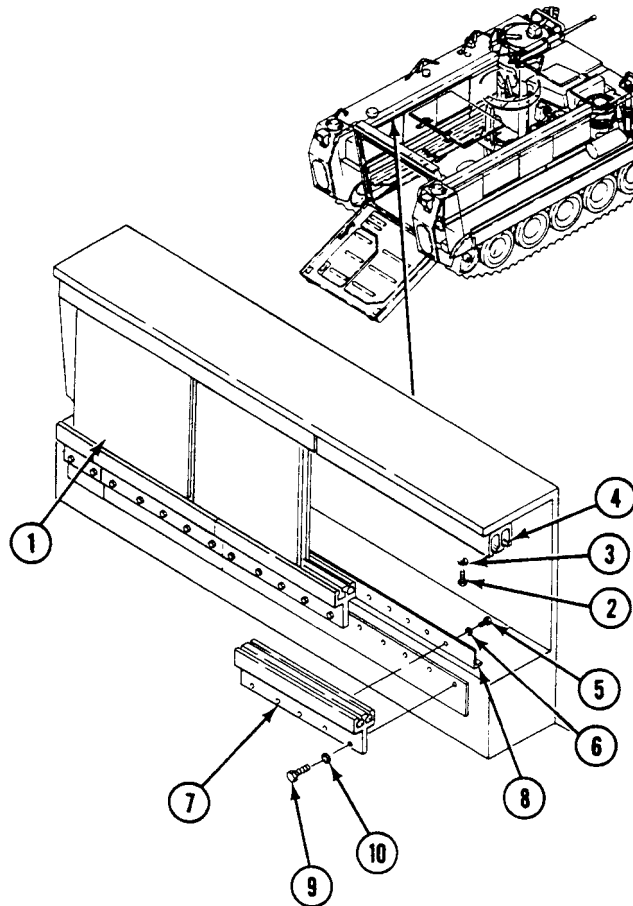

2. Remove 12 screws (2) and washers (3) from upper front track (4). Remove track from hull.

REPLACE LEFT SIDE SPALL LINERS (M113A3 ONLY) — Continued**0505 00**

3. Remove five screws (5) and washers (6) from lower front track (7) and support (8).
4. Remove five screws (9) and washers (10) from lower front track (7). Remove track from hull.
5. Slide four shields (1) forward and remove.

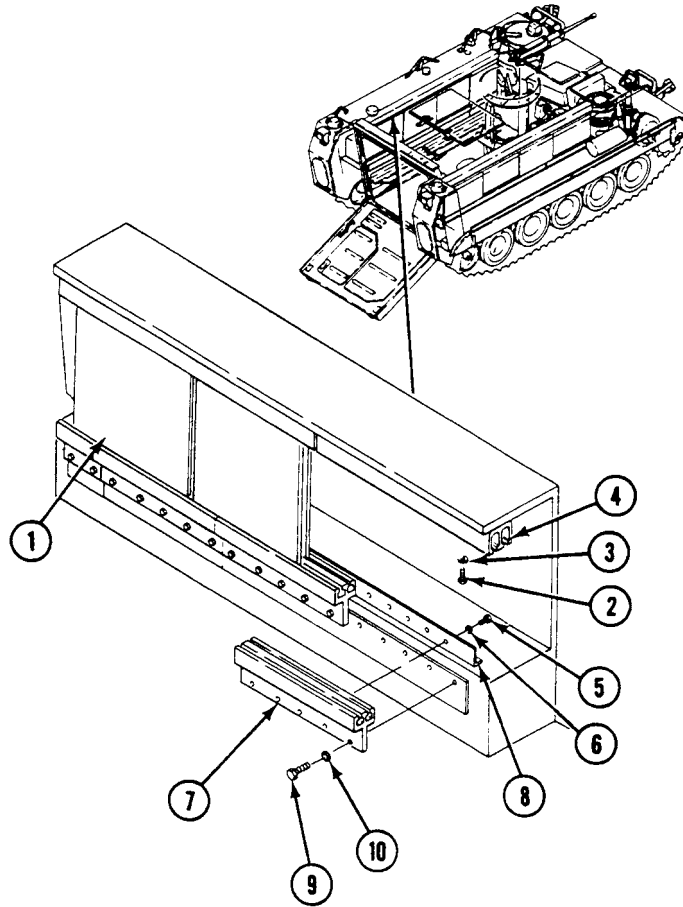

6. Remove 24 screws (1) and washers (2) from upper rear track (3). Remove track from hull. Have helper assist.

NOTE

If upper rear track needs to be replaced, do Step 7.

7. Loosen two screws (4) and slide two stop assemblies (5) off end of upper rear track (3).
8. Remove 12 screws (6) and washers (7) from middle lower track (8), two rear lower tracks (9) and (10) and support (11).
9. Remove 12 screws (12) and washers (13) from middle track (8) and two rear lower tracks (9) and (10). Remove tracks from hull.

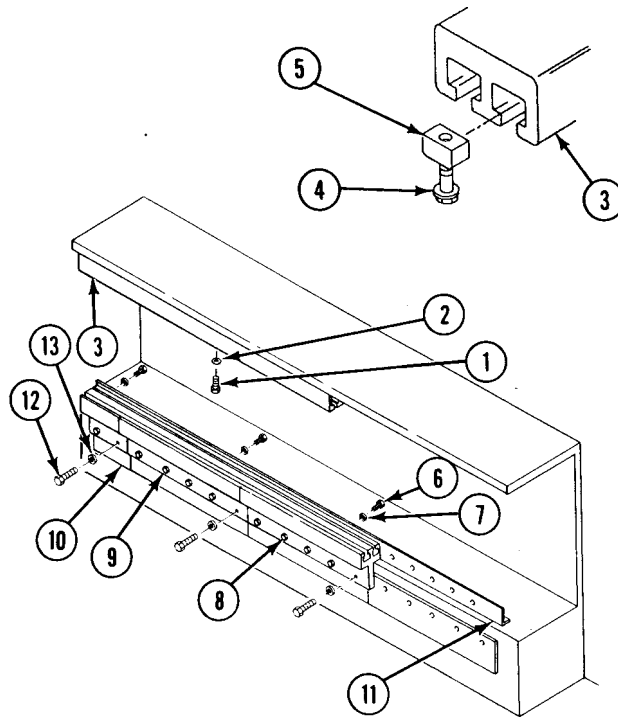

10. Remove 18 screws (14) and washers (15) from four supports (11). Remove support from hull.

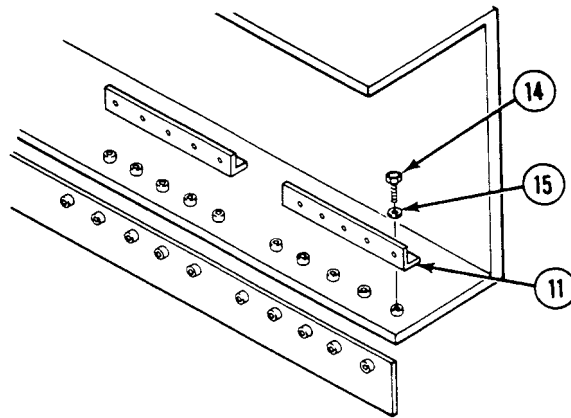

INSTALLATION

1. Install four supports (11) on hull. Secure with 18 screws (14) and washers (15). TIGHTEN SCREWS TO 32-34 LB-FT (43-46 N•m) TORQUE.

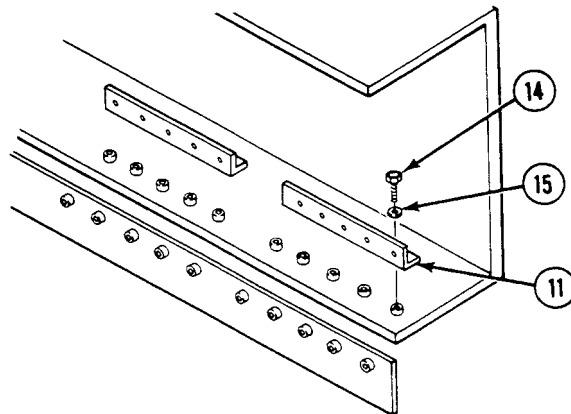

NOTE

Install short track on rear of vehicle first.

When using torque wrench with adapter, torque value must be corrected. Procedure for converting torque value is on (WP 0155 00).

2. Install two lower rear tracks (9) and (10) and middle track (8) on hull. Secure with 12 screws (12) and washers (13). TIGHTEN SCREWS TO 32-34 LB-FT (43-46 N•m) TORQUE.
3. Install two lower rear tracks (9) and (10) and middle lower track (8) on support (11). Secure with 12 screws (6) and washers (7). TIGHTEN SCREWS TO 32-34 LB-FT (43-46 N•m) TORQUE.

NOTE

If stop assemblies were removed in (Step 7), do (Step 4) and (Step 5).

4. Slide stop assembly (5) onto outside track of upper rear track (3). Position stop 4-3/4 to 5-1/4 inches (12.1 to 14.6 cm) from end of track. Secure stop with screw (4).
5. Slide other stop assembly (5) onto inside track of upper rear track (3). Position stop 3/8 to 7/16 inch (0.95 to 1.11 cm) from end of track. Secure stop with screw (4).
6. Install upper rear track (3) on hull. Secure with 24 screws (1) and washers (2). TIGHTEN SCREWS TO 32-34 LB-FT (43-46 N•m) TORQUE. Have helper assist.

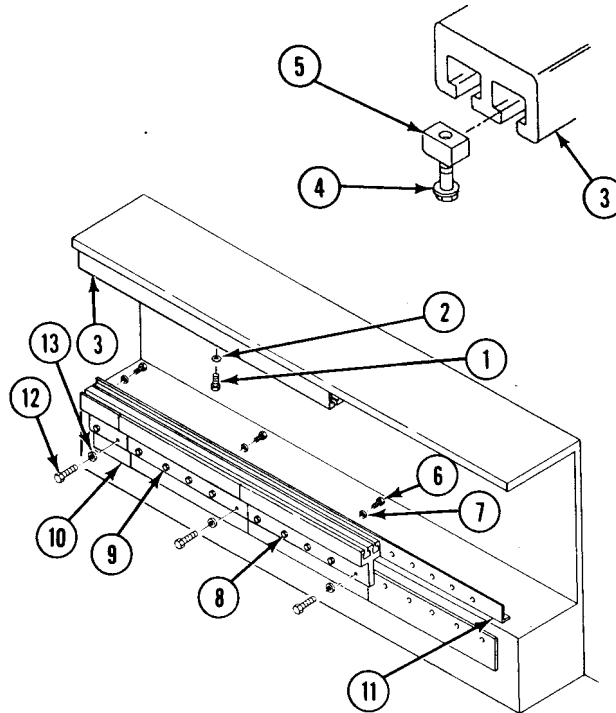

NOTE

Install rear shield on left track first and alternate the other three shields. There should be two shields on each track.

7. Install four shields (1) and position them to the rear.
8. Install lower front track (2) on hull. Secure with five screws (3) and washers (4). TIGHTEN SCREWS TO 32-34 LB-FT (43-46 N•m) TORQUE.
9. Install lower front track (2) on support (5). Secure with five screws (6) and washers (7). TIGHTEN SCREWS TO 32-34 LB-FT (43-46 N•m) TORQUE.
10. Install upper front track (8) on hull. Secure with 12 screws (9) and washers (10). TIGHTEN SCREWS TO 32-34 LB-FT (43-46 N•m) TORQUE.
11. Realign shields (1) to overlap.

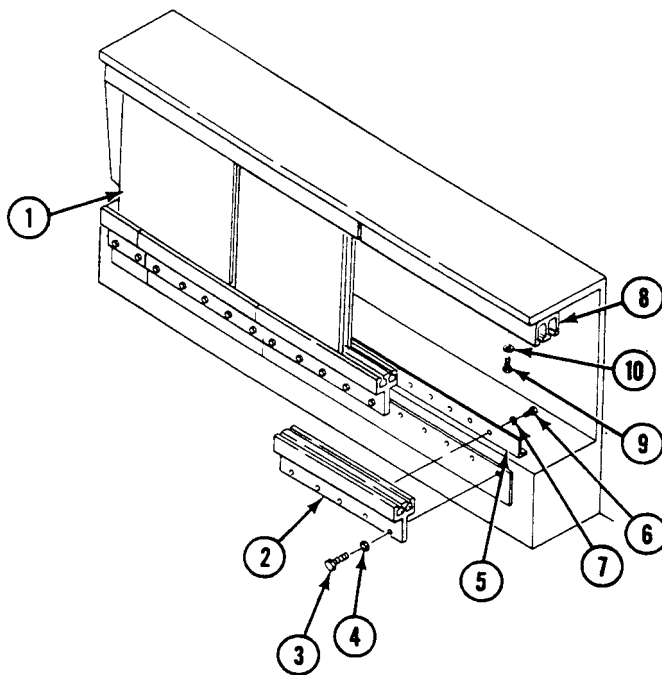
**FOLLOW-THROUGH STEPS**

1. Install quick release pins and plates (WP 0506 00).
2. Start engine (see your -10).
3. Raise and lock ramp (see your -10).
4. Stop engine (see your -10).

END OF TASK

REPAIR SPALL LINER QUICK RELEASE PINS AND PLATES (M113A3 ONLY)

0506 00

THIS WORK PACKAGE COVERS:

Removal (page 0506 00-1).
 Installation (page 0506 00-3).

INITIAL SETUP:

Maintenance Level

Unit

Personnel Required

Unit Mechanic

Tools and Special Tools

General Mechanic's Tool Kit (WP 0926 00, Item 65)
 Torque Wrench (WP 0926 00, Item 85)

References

See your -10

Materials/Parts

Lockwasher

Equipment Condition

Engine stopped (see your -10)
 Carrier blocked (see your -10)
 Ramp lowered (see your -10)

REMOVAL

NOTE

There are 6 quick release pins and 12 plates (6 front and 6 back) on the spall liner track. All are removed and installed the same way.

REPAIR SPALL LINER QUICK RELEASE PINS AND PLATES (M113A3 ONLY) —
Continued

0506 00

1. Remove quick release pin (1) from plates (2) and (3).
2. Remove screw (4), lockwasher (5), and washer (6) from lanyard (7) and quick release pin (1). Remove lanyard and pin from track. Discard lockwasher.
3. Remove two screws (8) and washers (9) from plate (2). Remove plate from track.
4. Remove two screws (10) and washers (11) from plate (3). Remove plate from track.

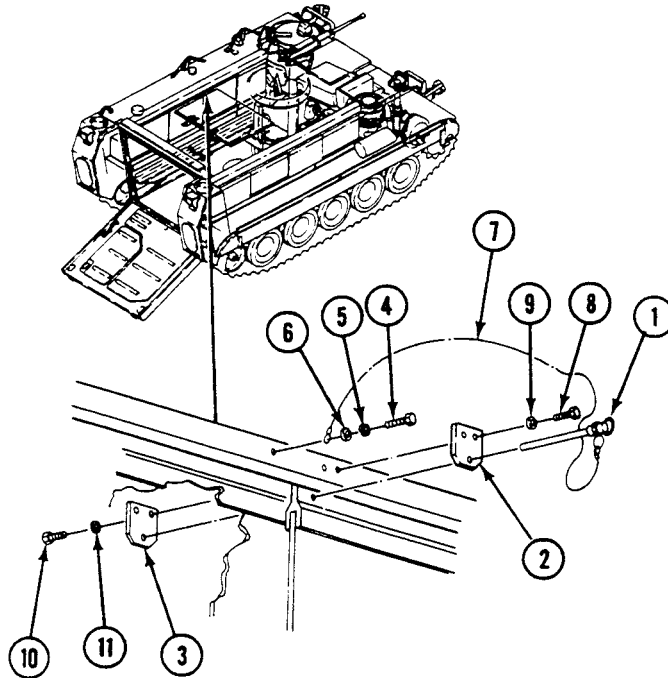

REPAIR SPALL LINER QUICK RELEASE PINS AND PLATES (M113A3 ONLY) —
Continued

0506 00

INSTALLATION

1. Install plate (3) on track with two screws (10) and washers (11). TIGHTEN SCREWS TO 32-34 LB-FT (43-46 N·m) TORQUE.
2. Install plate (2) on track with two screws (8) and washers (9). TIGHTEN SCREWS TO 32-34 LB-FT (43-46 N·m) TORQUE.
3. Install lanyard (7) and quick release pin (1) on track with screw (4), new lockwasher (5), and washer (6).
4. Install quick release pin (1) in plates (2) and (3).

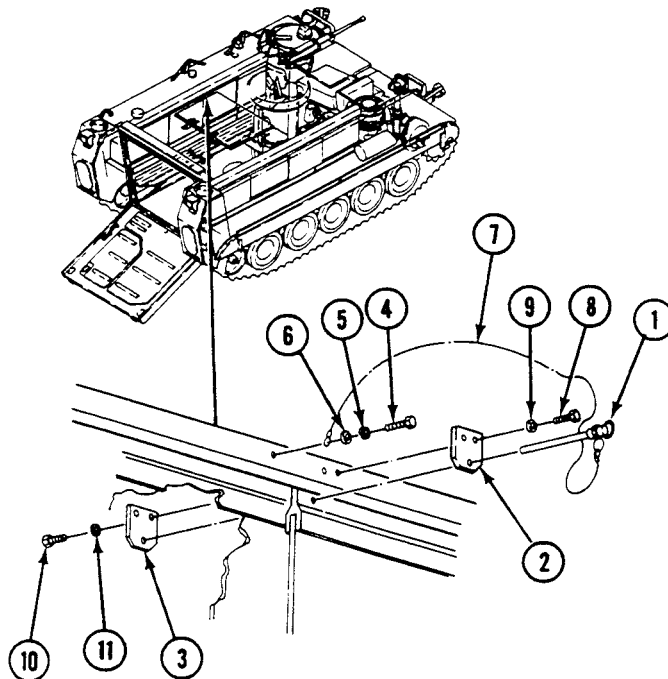
**FOLLOW-THROUGH STEPS**

1. Start engine (see your -10).
2. Raise and lock ramp (see your -10).
3. Stop engine (see your -10).

END OF TASK

REPLACE FORWARD SPALL LINER AND BRACKET (M113A3 ONLY)

0507 00

THIS WORK PACKAGE COVERS:

Removal (page 0507 00-1).
 Installation (page 0507 00-3).

INITIAL SETUP:

Maintenance Level

Unit

Personnel Required

Unit Mechanic

Tools and Special Tools

General Mechanic's Tool Kit (WP 0926 00, Item 65)
 Torque Wrench (WP 0926 00, Item 85)

References

See your -10

Materials/Parts

Locknut (8)

Equipment Condition

Engine stopped (see your -10)
 Carrier blocked (see your -10)
 Dome light disconnected (WP 0309 00)

REMOVAL

1. Remove four screws (1), washers (2), and locknuts (3) from lower spall liner backing plate (4) and sponson bracket (5). Discard locknuts.

REPLACE FORWARD SPALL LINER AND BRACKET (M113A3 ONLY) — Continued

0507 00

2. Remove four screws (1), washers (2), and locknuts (3) from upper spall liner backing plate (6) and upper hull bracket (7). Discard locknuts.
3. Remove six screws (8) and washers (9) from upper hull bracket (7). Remove bracket from hull.
4. Remove spall liner (10) from carrier.

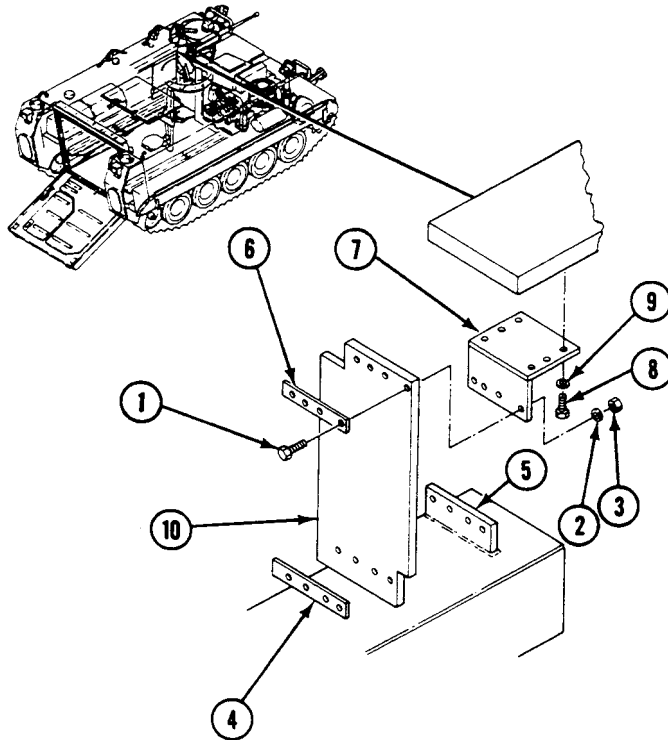

INSTALLATION

1. Secure spall liner (10) and lower backing plate (4) with four screws (1), washers (2), and new locknuts (3) to sponson bracket (5). TIGHTEN SCREWS TO 32-34 LB-FT (43-46 N·m) TORQUE.
2. Secure upper hull bracket (7) to hull with six screws (8) and washers (9). TIGHTEN SCREWS TO 32-34 LB-FT (43-46 N·m) TORQUE.
3. Install upper backing plate (6) to spall liner (10) with four screws (1), washers (2), and new locknuts (3). TIGHTEN SCREWS TO 32-34 LB-FT (43-46 N·m) TORQUE.

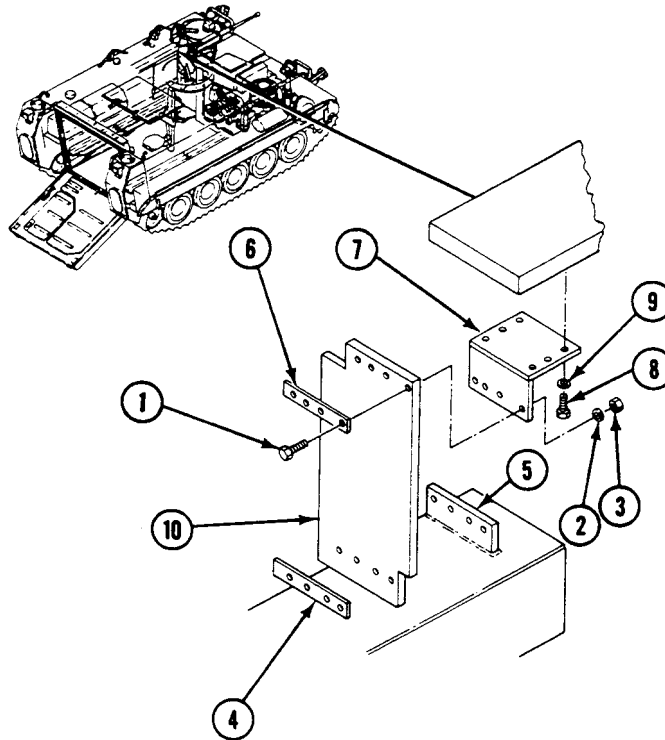
**FOLLOW-THROUGH STEPS**

1. Connect dome light (WP 0309 00).

END OF TASK

**REPLACE FORWARD UPPER RIGHT AND LEFT SIDE SPALL LINERS
(M113A3 ONLY)**

0508 00

THIS WORK PACKAGE COVERS:

Removal (page 0508 00-1).
Installation (page 0508 00-2).

INITIAL SETUP:

Maintenance Level

Unit

Personnel Required

Unit Mechanic

Tools and Special Tools

General Mechanic's Tool Kit (WP 0926 00, Item 65)
Screwdriver Set (WP 0926 00, Item 46)

References

See your -10

Materials/Parts

Lockwasher (14)

Equipment Condition

Engine stopped (see your -10)
Carrier blocked (see your -10)
Ramp lowered (see your -10)

REMOVAL

NOTE

Seven identical screws, washers, and lockwashers secure spall liners on the upper right and left sides of carrier overhead. Spall liners on both sides are removed and installed the same way.

1. Remove seven screws (1), washers (2), and lockwashers (3) from spall liner (4). Remove spall liner from ceiling. Discard lockwashers.

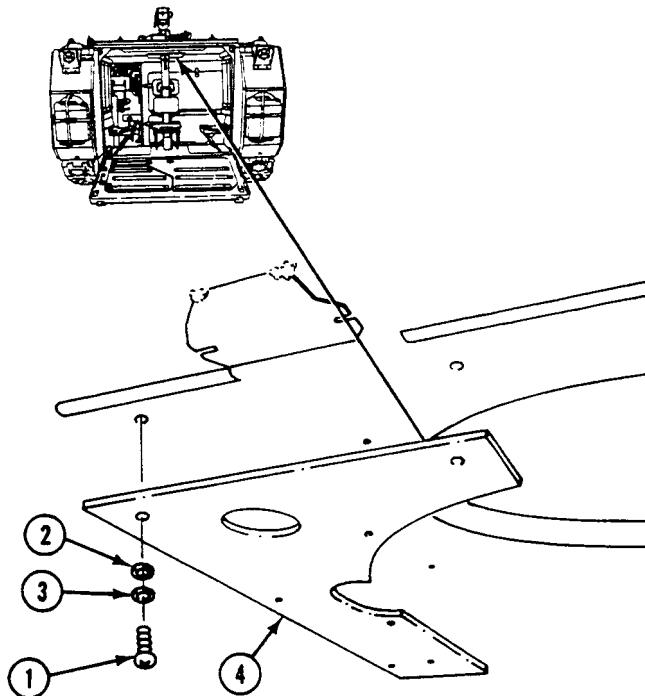

REPLACE FORWARD UPPER RIGHT AND LEFT SIDE SPALL LINERS (M113A3 ONLY) —
Continued

0508 00

INSTALLATION

1. Install spall liner (4) on ceiling with seven screws (1), washers (2), and new lockwashers (3).

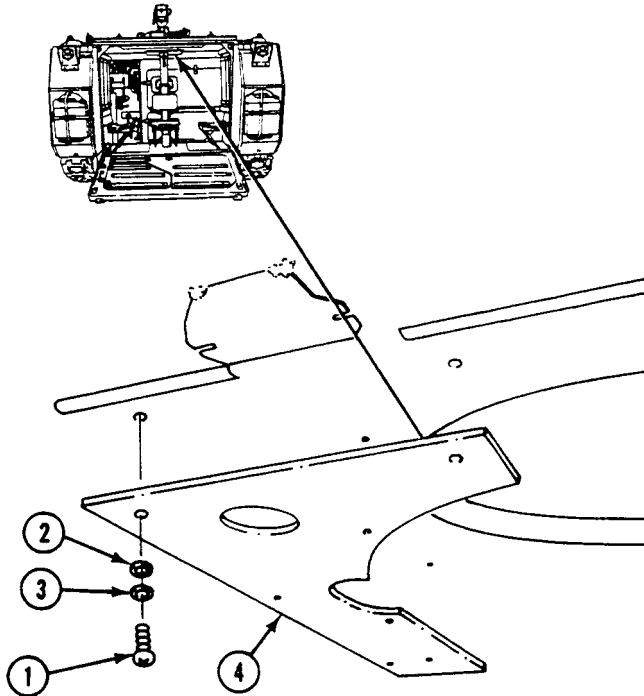
**FOLLOW-THROUGH STEPS**

1. Start engine (see your -10).
2. Raise and lock ramp (see Your -10).
3. Stop engine (see your -10).

END OF TASK

REPLACE SPALL LINER ON CARGO HATCH COVER (M113A3 ONLY)

0509 00

THIS WORK PACKAGE COVERS:

Removal (page 0509 00-1).
 Installation (page 0509 00-2).

INITIAL SETUP:

Maintenance Level

Unit

Personnel Required

Unit Mechanic

Tools and Special Tools

General Mechanic's Tool Kit (WP 0926 00, Item 65)
 Screwdriver Set (WP 0926 00, Item 46)

References

See your -10

Materials/Parts

Lockwasher (10)

Equipment Condition

Engine stopped (see your -10)
 Carrier blocked (see your -10)
 Ramp lowered (see your -10)
 Cargo hatch cover opened (see your -10)

REMOVAL

1. Remove 10 screws (1), washers (2), lockwashers (3), and spall liner plate (4) from cargo hatch cover. Discard lockwashers.

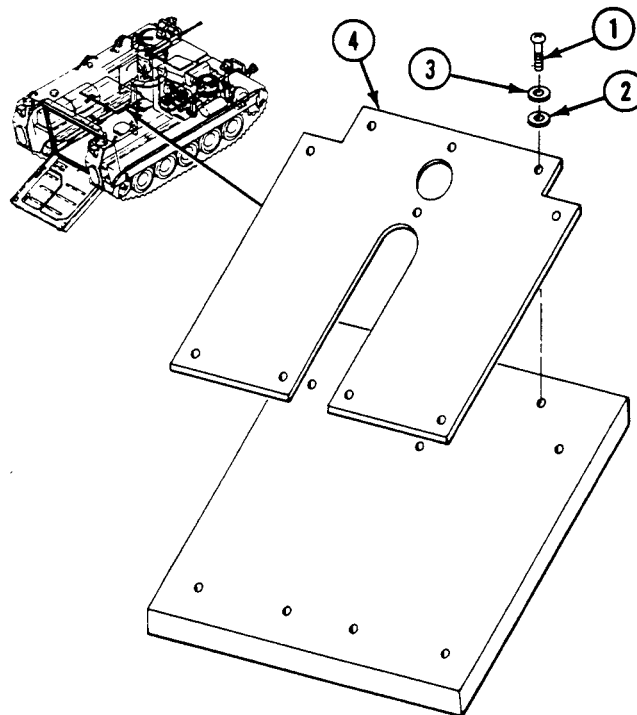

INSTALLATION

1. Install spall liner plate (4) on cargo hatch cover with 10 screws (1), washers (2), and new lockwashers (3).

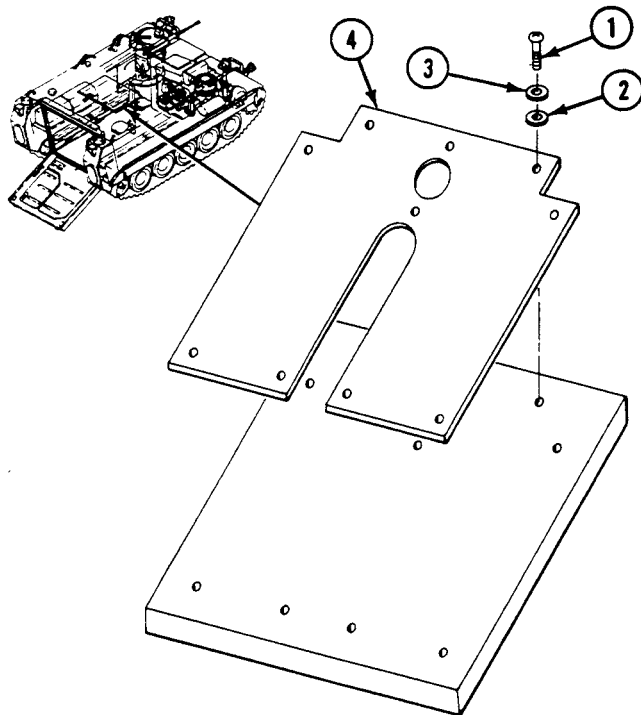
**FOLLOW-THROUGH STEPS**

1. Close cargo hatch cover (see your -10).
2. Start engine (see your -10).
3. Raise and lock ramp (see your -10).
4. Stop engine (see your -10).

END OF TASK

REPLACE REAR UPPER HULL SPALL LINER (M113A3 ONLY)

0510 00

THIS WORK PACKAGE COVERS:

- Removal (page 0510 00-1).
- Installation (page 0510 00-2).

INITIAL SETUP:

Maintenance Level

Unit

Personnel Required

Unit Mechanic
Helper (H)

Tools and Special Tools

- General Mechanic's Tool Kit (WP 0926 00, Item 65)
- Screwdriver Set (WP 0926 00, Item 46)

References

See your -10

Materials/Parts

Lockwasher (11)

Equipment Condition

- Engine stopped (see your -10)
- Carrier blocked (see your -10)
- Ramp lowered (see your -10)

REMOVAL

1. Have helper hold rear upper hull spall liner (1) in place. Remove 11 screws (2), washers (3), and lockwashers (4) from spall liner. Remove spall liner from carrier overhead. Discard lockwashers.

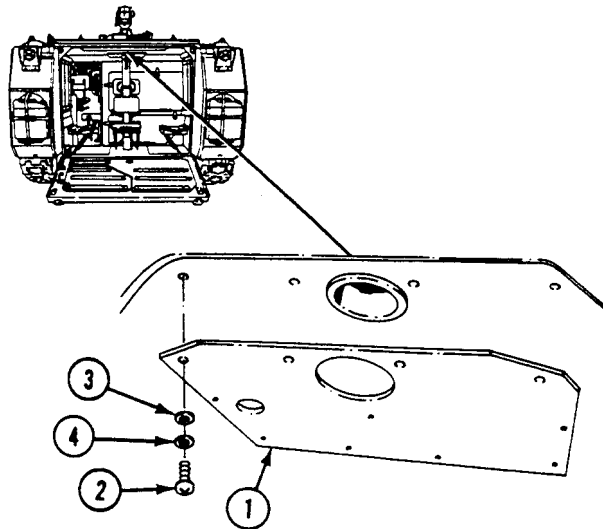

INSTALLATION

1. Have helper hold spall liner (1) in place. Secure with 11 screws (2), washers (3), and new lockwashers (4).

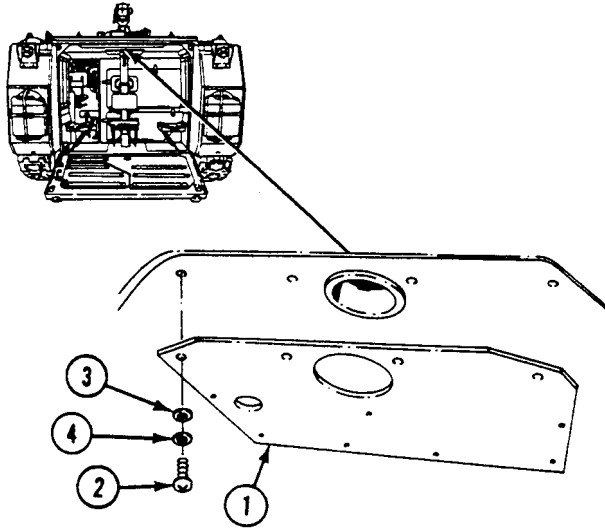
**FOLLOW-THROUGH STEPS**

1. Start engine (see your -10).
2. Raise and lock ramp (see your -10).
3. Stop engine (see your -10).

END OF TASK

REPLACE SPALL LINER ON RAMP DOOR (M113A3 ONLY)

0511 00

THIS WORK PACKAGE COVERS:

Removal (page 0511 00-1).
 Installation (page 0511 00-2).

INITIAL SETUP:

Maintenance Level

Unit

Personnel Required

Unit Mechanic

Tools and Special Tools

General Mechanic's Tool Kit (WP 0926 00, Item 65)
 Torque Wrench (WP 0926 00, Item 85)

References

See your -10

Materials/Parts

Lockwasher (6)

Equipment Condition

Engine stopped (see your -10)
 Carrier blocked (see your -10)
 Ramp lowered (see your -10)

REMOVAL

NOTE

Spall liner retainers are not used on all vehicles. Some vehicles use lockwashers and flat washers instead of flat washers (2) and retainers (3) to secure the spall liner to the ramp door.

1. Remove six screws (1), lockwashers (if equipped), washers (2), and three retainers (3) (if equipped) from spall liner (4). Remove spall liner from ramp door. Discard lockwashers.

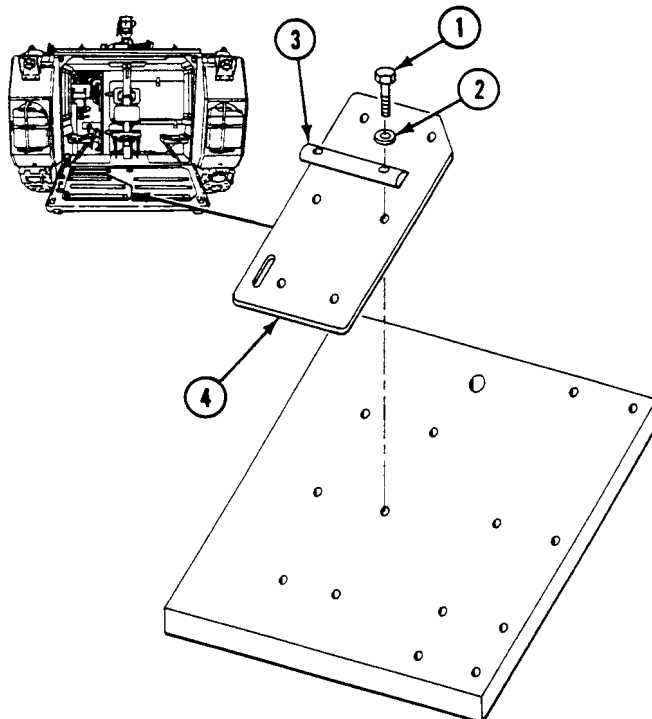

INSTALLATION

1. Place spall liner (4) on ramp door and secure with three retainers (3) (if equipped), six washers (2), new lockwashers (if equipped), and screws (1). TIGHTEN SCREWS TO 32-34 LB-FT (43-46 N·m) TORQUE.

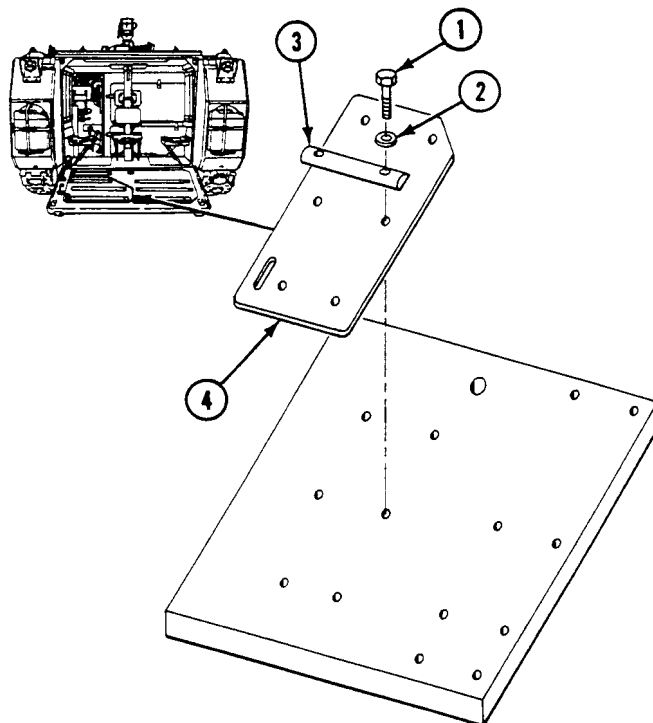
**FOLLOW-THROUGH STEPS**

1. Start engine (see your -10).
2. Raise and lock ramp (see your -10).
3. Stop engine (see your -10).

END OF TASK

REPLACE SPALL LINER ON RAMP (M113A3 ONLY)

0512 00

THIS WORK PACKAGE COVERS:

Removal (page 0512 00-1).
 Installation (page 0512 00-2).

INITIAL SETUP:

Maintenance Level

Unit

Personnel Required

Unit Mechanic

Tools and Special Tools

General Mechanic's Tool Kit (WP 0926 00, Item 65)
 Torque Wrench (WP 0926 00, Item 85)

References

See your -10

Materials/Parts

Lockwasher (12)

Equipment Condition

Engine stopped (see your -10)
 Carrier blocked (see your -10)
 Ramp lowered (see your -10)

REMOVAL

NOTE

Spall liner retainers are not used on all vehicles. Some vehicles use lockwashers and flat washers instead of flat washers (2) and retainers (3) to secure the spall liner to the ramp.

1. Remove 12 screws (1), lockwashers (if equipped), washers (2), and six retainers (3) (if equipped) from spall liner (4). Remove spall liner from ramp. Discard lockwashers.

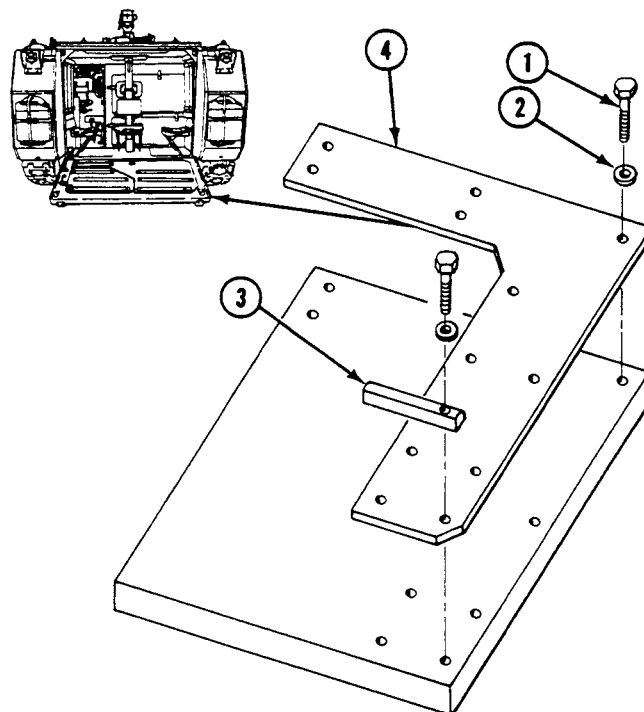

INSTALLATION

1. Place spall liner (4) on ramp. Secure with six retainers (3) (if equipped), 12 washers (2), new lockwashers (if equipped), and screws (1). **TIGHTEN SCREWS TO 32-34 LB-FT (43-46 N·m) TORQUE.**

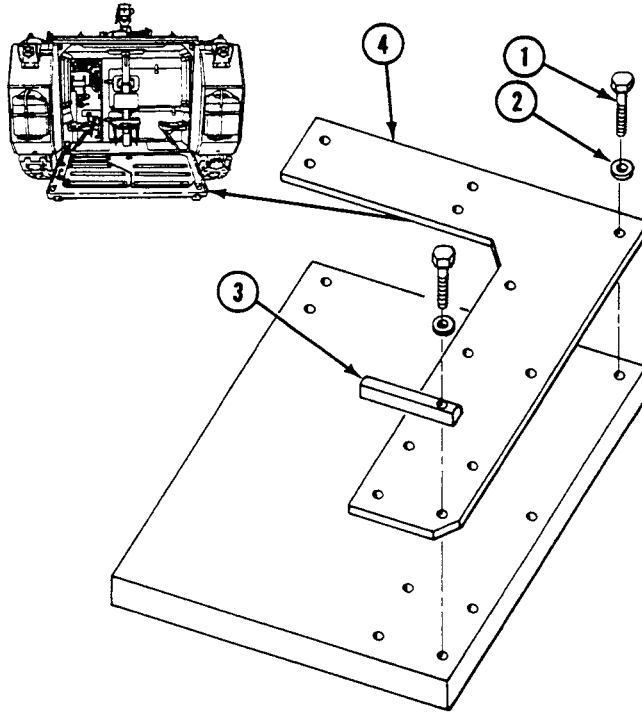
**FOLLOW-THROUGH STEPS**

1. Start engine (see your -10).
2. Raise and lock ramp (see your -10).
3. Stop engine (see your -10).

END OF TASK

RAISE/LOWER INOPERABLE/UNSAFE RAMP

0513 00

THIS WORK PACKAGE COVERS:

Raise Inoperable/Unsafe Ramp (page 0513 00-2).
Lower Inoperable/Unsafe ramp (page 0513 00-7).

INITIAL SETUP:

Maintenance Level

Unit

Personnel Required

Unit Mechanic

Tools and Special Tools

General Mechanic's Tool Kit (WP 0926 00, Item 65)
Powered lifting device with rated lift capacity of at least
700 lbs (318 kg)

References

See your -10

Equipment Condition

Engine stopped (see your -10)
Carrier blocked (see your -10)

SERVICING**RAISE INOPERABLE/UNSAFE RAMP**

An inoperable/unsafe ramp can fall and kill soldiers. Follow these procedures and never get behind a raised, inoperable/unsafe ramp that is not secured.

NOTE

This task is for carriers without armor only.

1. Connect cable (1) to tow pintle (2) of ramp and to lifting hook of powered lifting device. Position cable under center of ramp and out at top edge. If required, use crowbar to raise ramp slightly.
2. Raise ramp. Make sure ramp actuator cable does not get caught between ramp and hull.
3. Lock driver's ramp lock handle (see your -10)

4. Install tow cable (3), tow hook (4), headed pin (5), and safety clip (6) to right rear towing eye (7).

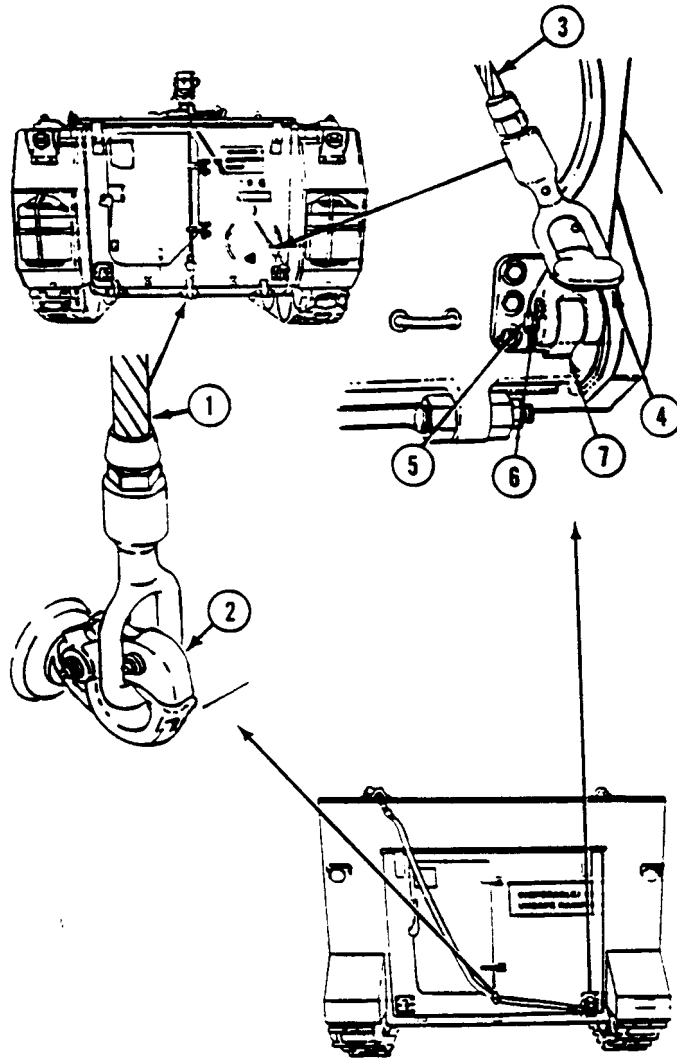

5. Secure end of cable (1) with tow hook (2), headed pin (3), and safety clip (4) as follows:

a. Antenna brush guards (5) on all vehicles.

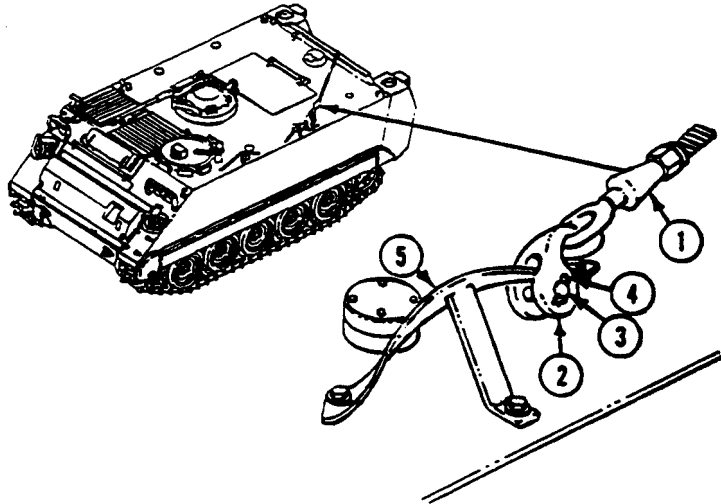

b. Mortar hatch catch (6) on M1064A3.

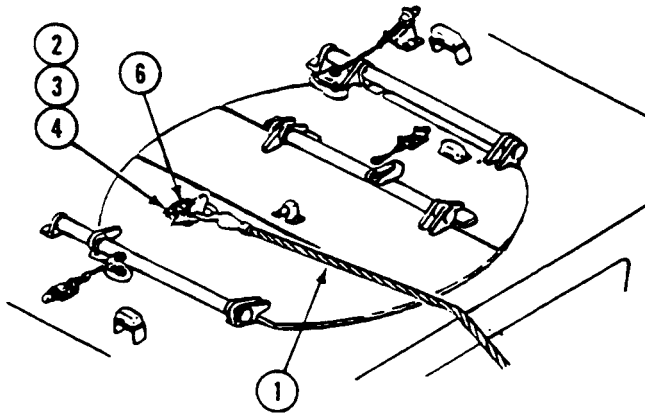

- c. Through tow pintle (7) to rear left lifting eye (8) on M577A3 and M1068A3.

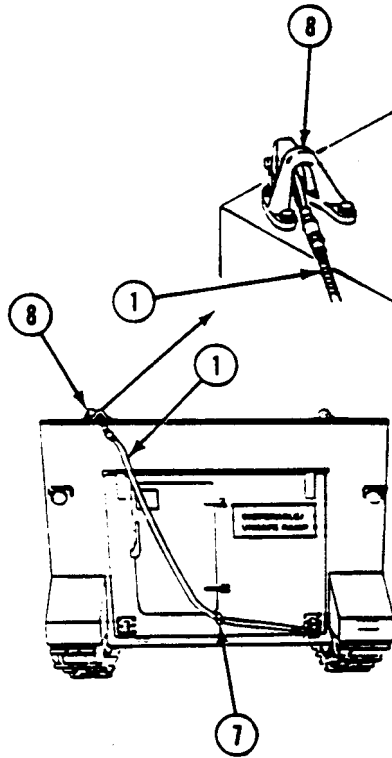

6. Close ramp access door (9) and secure combat lock (10) with padlock (11) from tool bag (See your -10).

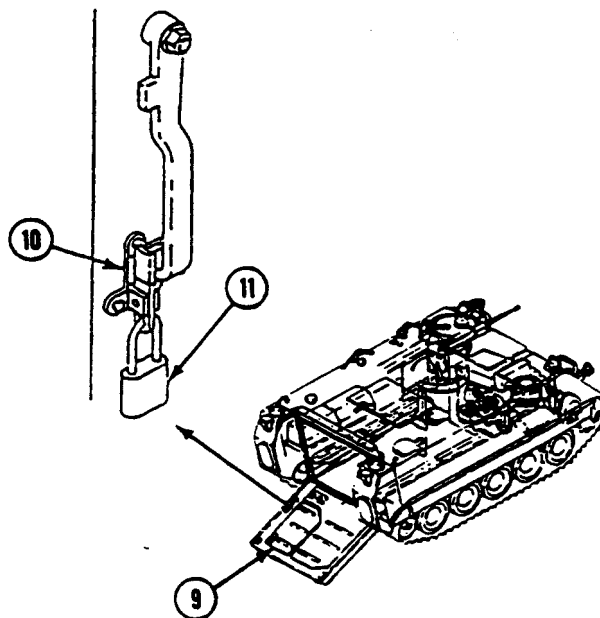

7. Tag the driver's ramp lock lever with the following warning.
 - a. **WARNING!**
Inoperable/unsafe ramp. A falling ramp can kill you. Do not remove cable securing ramp unless proper lifting equipment is attached.
8. Post sign on ramp with the following warning.
 - a. **WARNING!**
Inoperable/unsafe ramp. A falling ramp can kill you. Do not remove cable securing ramp unless proper lifting equipment is attached.
9. Release load from lifting device and remove cable (12) from tow pintle (13).

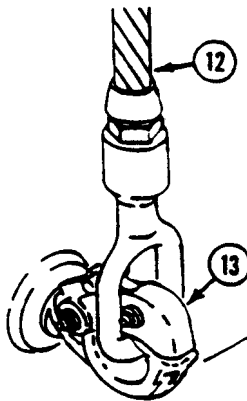

LOWER INOPERABLE/UNSAFE RAMP

1. Make sure driver's ramp lock is locked.
2. Connect cable (1) to tow pintle (2) and to lifting hook of powered lifting device. Apply load to lifting device.

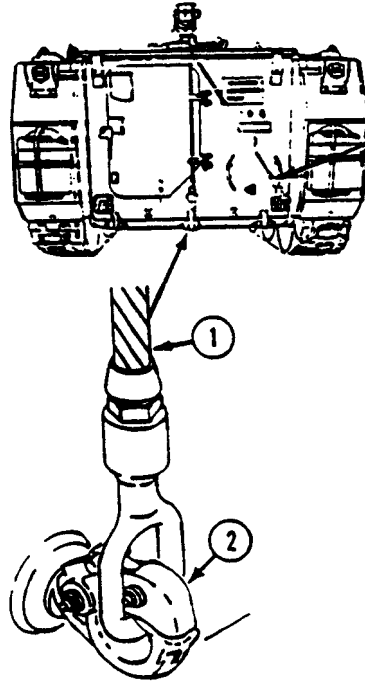

3. Remove safety clip (3), headed pin (4), tow hook (5), and tow cable (6) from the following location as applicable:

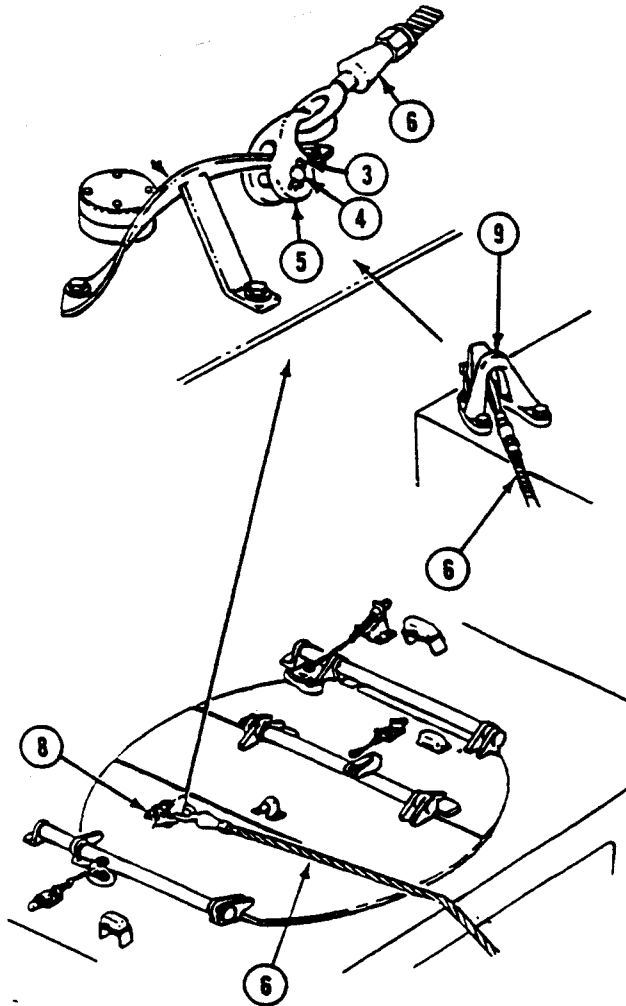

- a. Antenna brush guard (7) on all vehicles.
- b. Mortar hatch catch (8) on M1064A3.
- c. Rear left lifting eye (9) on M577A3 and M1068A3.

4. Remove safety clip (10), headed pin (11), tow hook (12) and tow cable (13) from right rear towing eye.

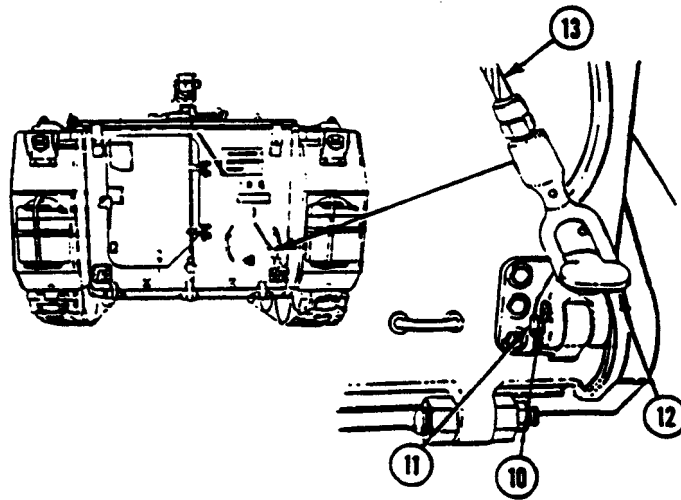

5. Unlock driver's ramp lock handle.
6. Hold ramp actuator handle down as powered lifting device lowers ramp.
7. Disconnect cable (1) from tow pintle (2) and lifting hook of powered lifting device. If required, use crowbar to raise ramp slightly for cable removal.

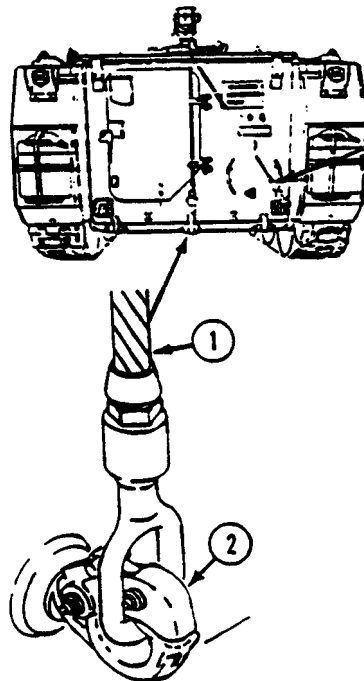

END OF TASK

REPLACE RAMP SEAL

0514 00

THIS WORK PACKAGE COVERS:

Removal (page 0514 00-1).
 Installation (page 0514 00-2).

INITIAL SETUP:

Maintenance Level

Unit

References

See your -10

Tools and Special Tools

General Mechanic's Tool Kit (WP 0926 00, Item 65)

Equipment Condition

Engine stopped (see your -10)

Personnel Required

Unit Mechanic

Carrier blocked (see your -10)

Ramp lowered (see your -10)

REMOVAL

1. Bend retaining strip (1) up. Remove upper seal (2) from hull rear bulkhead.
2. Bend three retaining strips (3) up. Remove lower seal (4) from hull rear bulkhead.

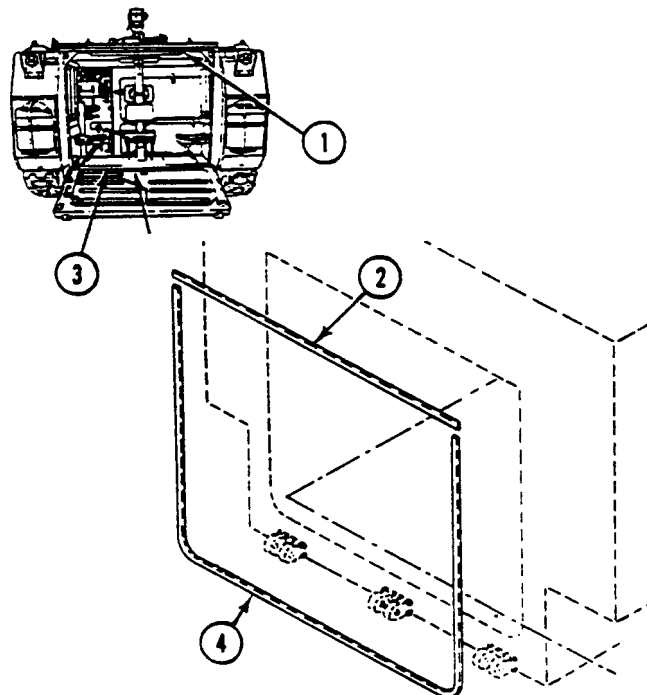

INSTALLATION**NOTE**

Trim seal to fit.

1. Place lower seal (4) on rear bulkhead. Bend three retaining strips (3) on seal to secure in place.
2. Place upper seal (2) on rear bulkhead. Bend retaining strip (1) down on seal to secure in place.

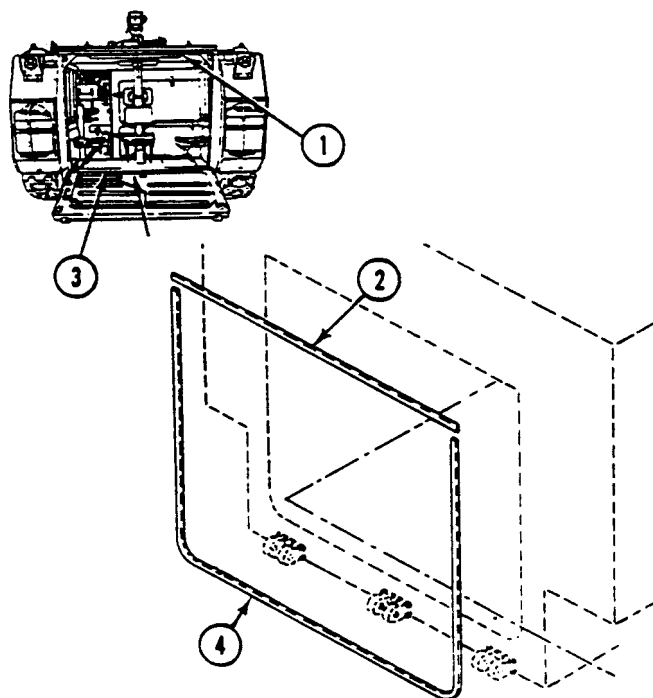
**FOLLOW-THROUGH STEPS**

1. Start engine (see your -10).
2. Perform ramp seal chalk test (WP 0521 00).
3. Raise and lock ramp (see your -10).
4. Stop engine (see your -10).

END OF TASK

REPLACE RAMP DRAIN PLUGS

0515 00

THIS WORK PACKAGE COVERS:

Removal (page 0515 00-1).
 Installation (page 0515 00-1).

INITIAL SETUP:

Maintenance Level

Unit

Personnel Required

Unit Mechanic

Tools and Special Tools

General Mechanic's Tool Kit (WP 0926 00, Item 65)

References

See your -10

Materials/Parts

Antiseize compound
 (WP 0928 00, Item NSN-8030-00-251-3980)

Equipment Condition

Engine stopped (see your -10)
 Carrier blocked (see your -10)
 Ramp raised and locked (see your -10)

REMOVAL

1. Remove three pipe plugs (1) from ramp (2).

INSTALLATION

1. Apply thin coat of antiseize compound to external tapered threads of three pipe plugs (1).
2. Install three pipe plugs (1) on ramp (2).

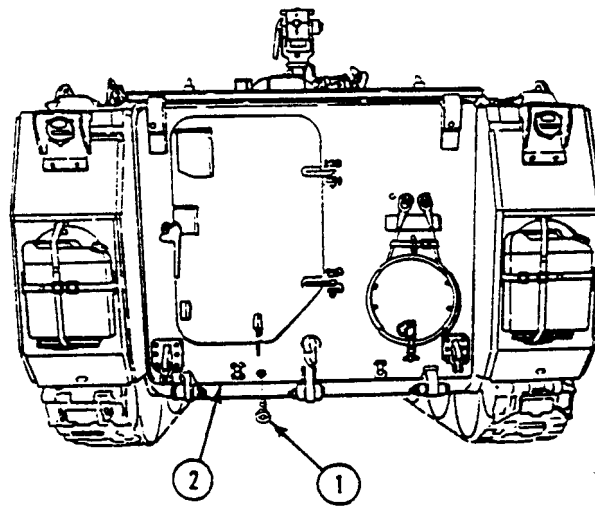

END OF TASK

REPLACE RAMP BRACKET (M113A3, M577A3, AND M1068A3 ONLY)

0516 00

THIS WORK PACKAGE COVERS:

Removal (page 0516 00-1).
 Installation (page 0516 00-1).

INITIAL SETUP:

Maintenance Level

Unit

References

See your -10

Tools and Special Tools

General Mechanic's Tool Kit (WP 0926 00, Item 65)

Equipment Condition

Engine stopped (see your -10)

Personnel Required

Unit Mechanic

Carrier blocked (see your -10)

Ramp raised and locked (see your -10)

REMOVAL

1. Remove four screws (1), washers (2), and bracket (3) from ramp (4).

INSTALLATION

1. Install bracket (3) on ramp (4). Secure with four screws (1) and washers (2).

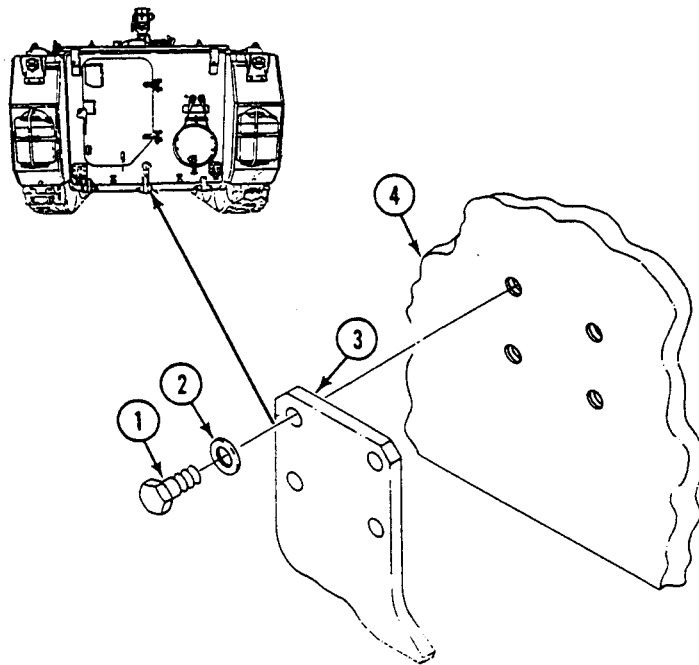

END OF TASK

REPLACE RAMP DOOR STOP BRACKET

0517 00

THIS WORK PACKAGE COVERS:

Removal (page 0517 00-1).
 Installation (page 0517 00-1).

INITIAL SETUP:

Maintenance Level
 Unit

References
 See your -10

Tools and Special Tools
 General Mechanic's Tool Kit (WP 0926 00, Item 65)

Equipment Condition
 Engine stopped (see your -10)
 Carrier blocked (see your -10)
 Ramp raised and locked (see your -10)

Materials/Parts
 Locknut
Personnel Required
 Unit Mechanic

REMOVAL

1. Remove screw (1) and locknut (2) from bracket (3). Discard locknut.
2. Remove four screws (4) and bracket (3) from ramp (5).

INSTALLATION

1. Install bracket (3) on ramp (5). Secure with four screws (4).
2. Install screw (1) and new locknut (2) on bracket (3).

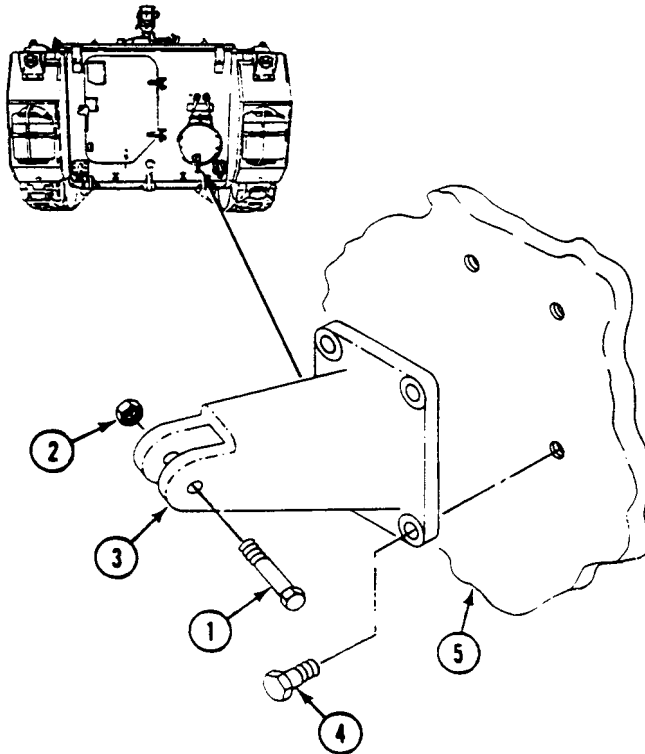

END OF TASK

REPLACE RAMP DOOR HOOK AND SPRING

0518 00

THIS WORK PACKAGE COVERS:

Removal (page 0518 00-1).
 Adjustment (page 0518 00-2).

INITIAL SETUP:

Maintenance Level

Unit

References

See your -10

Tools and Special Tools

General Mechanic's Tool Kit (WP 0926 00, Item 65)

Equipment Condition

Engine stopped (see your -10)

Materials/Parts

Locknut

Carrier blocked (see your -10)

Personnel Required

Unit Mechanic

Ramp raised and locked (see your -10)

REMOVAL

1. Remove locknut (1), screw (2), two washers (3), spring (4), two spacers (5), two rubber washers (6), and hook (7) from mount on door (8). Discard locknut.

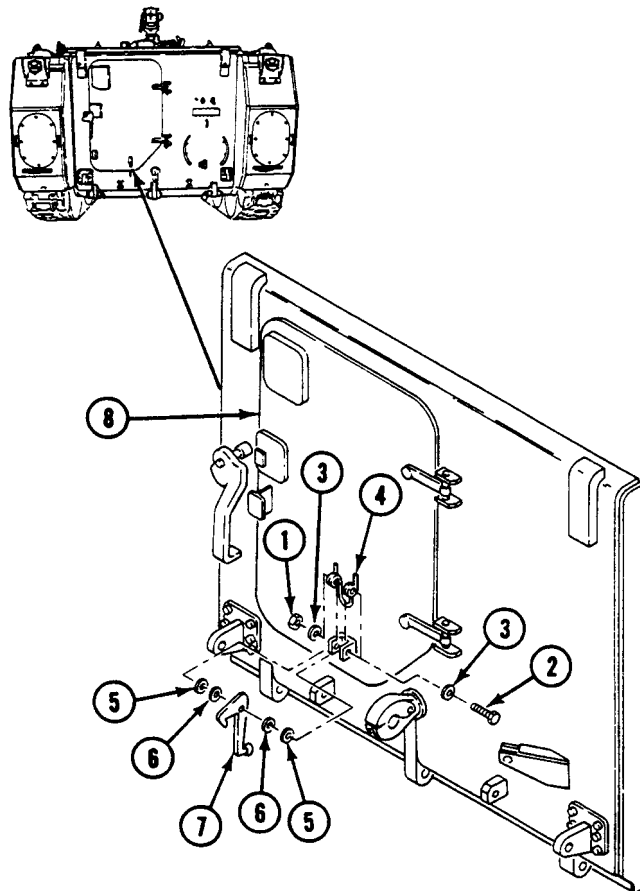

INSTALLATION

1. Align hook (7), two rubber washers (6), spacers (5), spring (4), and two washers (3) with mount on door (8). Secure with screw (2) and new locknut (1).

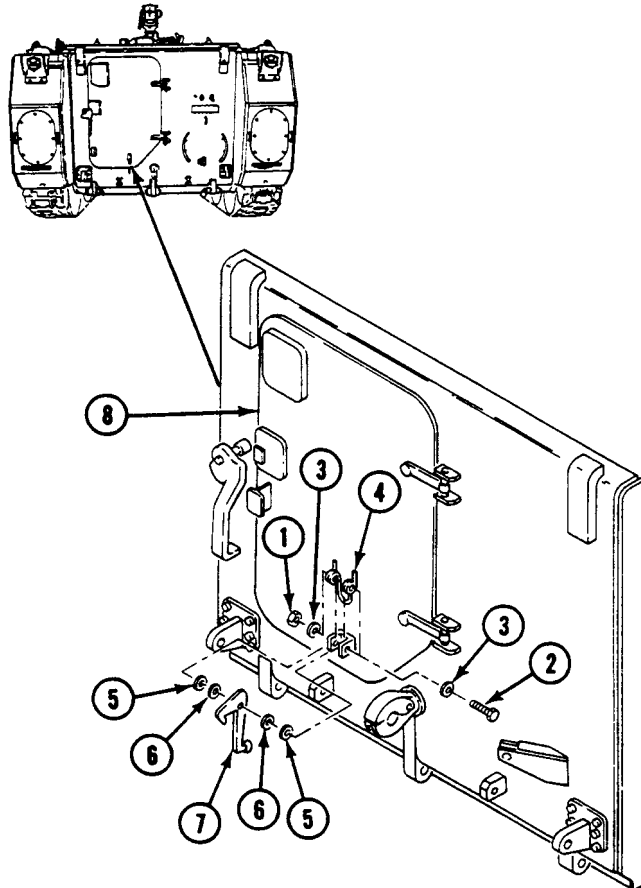
**FOLLOW-THROUGH STEPS**

1. Open and close ramp door to check that ramp door hook and spring work right.

END OF TASK

REPLACE RAMP DOOR HANDLES AND SHAFT

0519 00

THIS WORK PACKAGE COVERS:

- Removal (page 0519 00-1).
- Installation (page 0519 00-2).
- Adjustment (page 0519 00-3).

INITIAL SETUP:

Maintenance Level

Unit

Personnel Required

Unit Mechanic

Tools and Special Tools

General Mechanic's Tool Kit (WP 0926 00, Item 65)

References

See your -10

Materials/Parts

- Locknut
- Lockwasher (2)
- Preformed packing

Equipment Condition

- Engine stopped (see your -10)
- Carrier blocked (see your -10)
- Ramp raised and locked (see your -10)

REMOVAL

1. Remove pin (1), two washers (2), and door lock (3) from mount on ramp.
2. Remove locknut (4), inside handle (5), and inside washer(s) (6), and spacer (7) from shaft (8). Discard locknut.
3. Remove key (9) from shaft (8).
4. Remove two screws (10), lockwashers (11), washers (12), and outside handle (13) from shaft (8). Discard lockwashers.
5. Remove shaft (8), washer(s) (14), and preformed packing (15) from ramp (16). Discard packing.

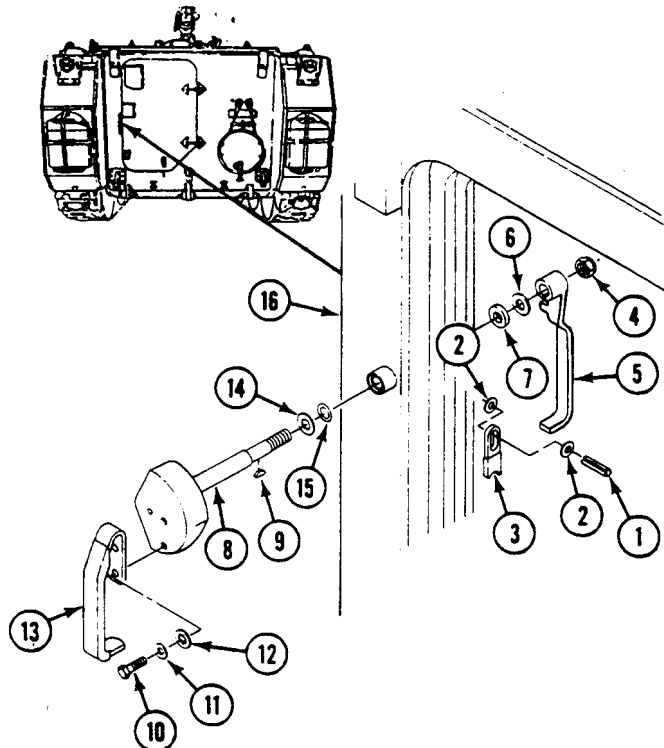

INSTALLATION

1. Install new preformed packing (15), washer(s) (14), and shaft (8) on ramp (16).
2. Install outside handle (13) on shaft (8). Secure with two washers (12), new lockwashers (11), and screws (10).
3. Install key (9) on shaft (8).
4. Install inside washer(s) (6), spacer (7), and inside handle (5) on shaft (8). Secure with new locknut (4).

NOTE

Make sure key fits properly into inside handle.

5. Align door lock (3) and two washers (2) with mount on ramp (16). Secure with pin (1).

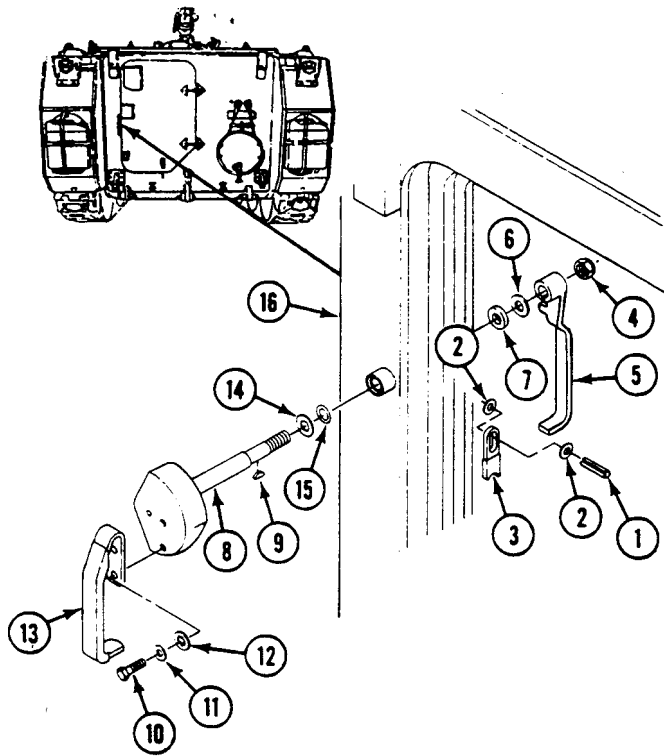

6. Adjust ramp door handles (Steps 1 - 4).

ADJUSTMENT**NOTE**

When adjusted right, door handle will have no end play. Ramp door should be flush with ramp in the closed position.

1. Remove handles (1) and (2) from ramp (3) (Steps 2 - 5).
2. Remove or install washer(s) (4) and (5) on shaft of handle (1) from inside and outside ramp (3) to obtain proper fit.

NOTE

Install washer(s) (4) on inside and washer(s) (5) on outside of ramp up to a maximum of nine at each position.

3. Install handles (1) and (2) on ramp (Steps 1 - 4).
4. Repeat steps as often as needed to obtain right adjustment.

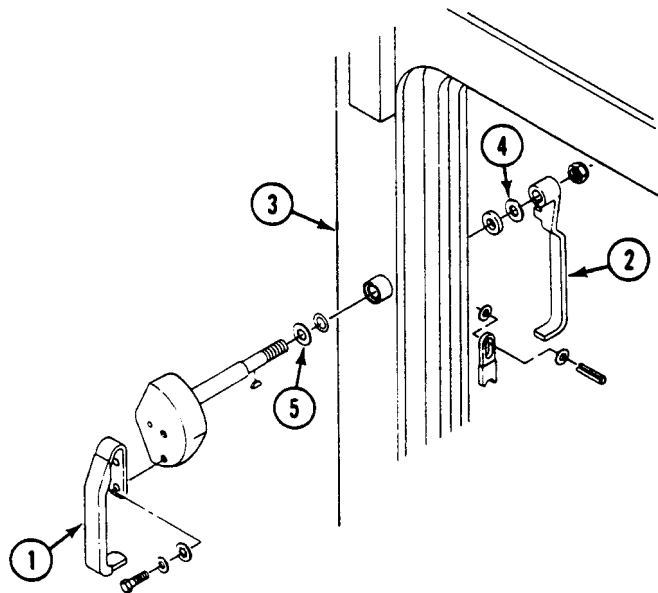
**FOLLOW-THROUGH STEPS**

1. Open and close ramp door to check that ramp door handles are installed right.
2. Perform chalk test (WP 0155 00page 5c).

END OF TASK

REPLACE RAMP DOOR SEAL

0520 00

THIS WORK PACKAGE COVERS:

Removal (page 0520 00-1).
 Adjustment (page 0520 00-2).

INITIAL SETUP:

Maintenance Level

Unit

References

See your -10

Tools and Special Tools

General Mechanic's Tool Kit (WP 0926 00, Item 65)

Equipment Condition

Engine stopped (see your -10)

Carrier blocked (see your -10)

Ramp raised and locked (see your -10)

Personnel Required

Unit Mechanic

REMOVAL

NOTE

Check ramp door seal in same manner as ramp seal (WP 0521 00). Chalk pattern should be evenly distributed over interior sealing lip of ramp door. If pattern is uneven, adjust door handle (WP 0519 00). If adjustment of handle does not solve problem, notify your supervisor.

1. Bend five retainer strips (1), on door (2), away from door seal (3).
2. Remove damaged seal (3) from door (2).

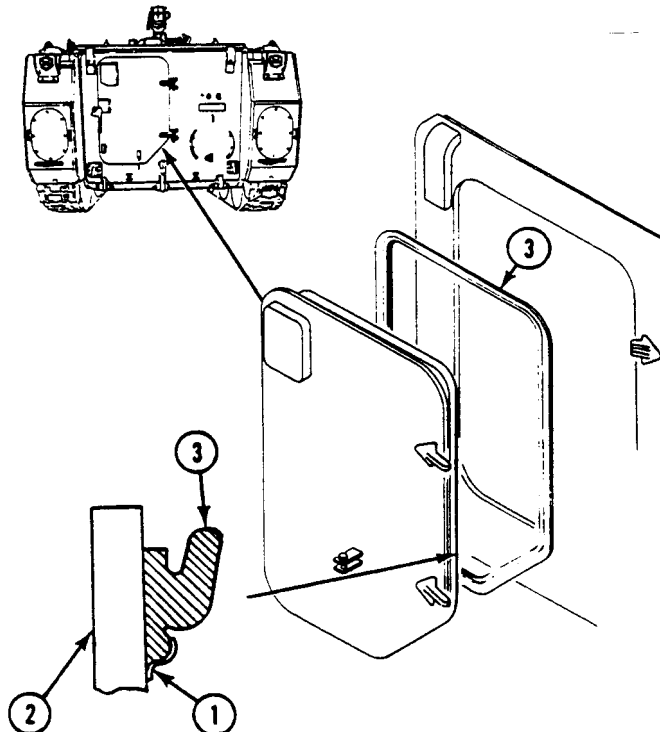

INSTALLATION

1. Place door seal (3) on door (2).
2. Bend five retainer strips (1), on door (2), down on seal (3) to secure in place.

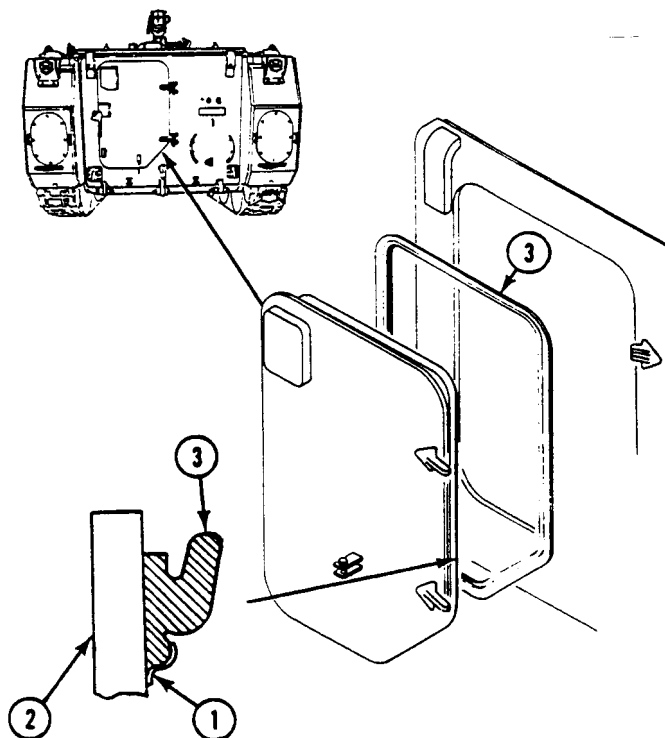
**FOLLOW-THROUGH STEPS**

1. Close ramp door to check that ramp door seal works right (see your -10).
2. Perform chalk test (WP 0155 00page 5c).

END OF TASK

ADJUST RAMP LOCK (M113A3 AND M1059A3 ONLY)

0521 00

THIS WORK PACKAGE COVERS:

- Ramp Lock Test (page 0521 00-1).
- Ramp Seal Test (page 0521 00-1).
- Ramp Lock Adjustment (page 0521 00-2).

INITIAL SETUP:

Maintenance Level

Unit

Personnel Required

Unit Mechanic
Helper (H)

Tools and Special Tools

General Mechanic's Tool Kit (WP 0926 00, Item 65)

References

See your -10

Materials/Parts

- Cotter pin
- Flat washer (as needed)
- Key washer (8)
- Key washer (carriers with hex shaped ramp lock rods only) (2)

Equipment Condition

Engine stopped (see your -10)
Carrier blocked (see your -10)

TEST AND INSPECTION

RAMP LOCK TEST

1. Turn MASTER SWITCH ON. Start engine (see your -10).
2. Raise and lock ramp (see your -10).
3. With ramp up, ramp lock handle should latch tight. Swing handle forward until it clicks. If linkage is adjusted right, it should take a good push to latch the handle.
4. Check that top, sides, and bottom of ramp are aligned right.

NOTE

Ramp seal should be compressed enough to prevent water leakage, yet without metal-to-metal contact between ramp and hull.

5. If ramp handle will not latch or ramp does not seal, perform ramp seal test (Step 1) and adjust ramp lock (Step 1).

RAMP SEAL TEST

WARNING



Lowering ramp could injure personnel. Make sure no one is in ramp zone before you lower ramp. If tactical situation permits, sound horn before dropping ramp.

1. Lower ramp (see your -10).

2. Check ramp-to-hull seal. Replace cracked, worn, or torn seal (WP 0514 00).
3. If seal looks all right, apply a heavy coat of white chalk to sealing lip of ramp seal.
4. Raise and lock ramp. Unlock and lower ramp (see your -10).
5. Check ramp for chalk transfer from seal to ramp surface.
6. If chalk is not evenly distributed, adjust ramp lock (Step 1).
7. If there is no chalk along bottom of ramp or if no contact shows on bottom of ramp, replace seal (WP 0514 00).

ADJUSTMENT

RAMP LOCK ADJUSTMENT

NOTE

All ramp adjustments must be done with the ramp down. Always adjust forward linkage first.

1. Lower ramp (see your -10).
2. Remove cotter pin (1) and headed pin (2) from clevis (3). Discard cotter pin.
3. Disconnect clevis (3) from link (4).
4. Swing ramp lock handle (5) forward. If catch (6) does not engage with striker (7), adjust catch (Step 5). If catch and striker adjustment is all right, go to Step 7.

NOTE

Install the same number of flat washers on each side of all four supports.

5. To adjust catch (6) and striker (7), remove eight screws (8) and key washers (9) from four supports (10). Discard key washers. Remove or add new flat washers (11), as required, to shim between supports (10) and hull top plate.

6. Install eight new key washers (9). Tighten eight screws (8). If shimmed right, catch (6) on lock handle (5) will engage firmly with striker (7). Bend keys to secure screws.

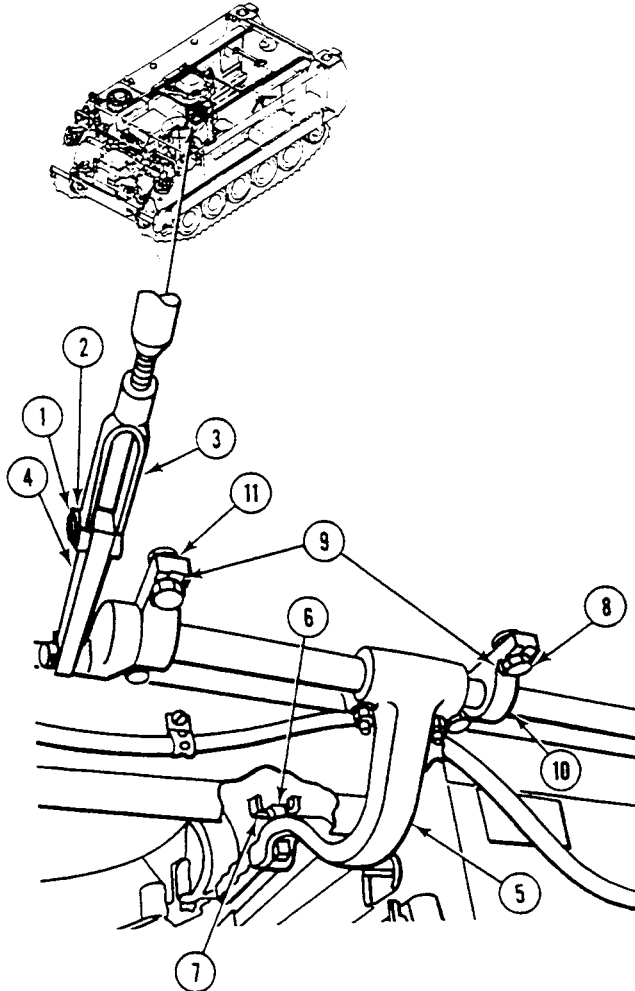
**NOTE**

Test is for one side of ramp lock adjustment. Adjust both sides of carrier at the same time.
Have helper assist.

NOTE

Some carriers are equipped with flat shaped ramp lock rods, while other carriers are equipped with hex shaped ramp lock rods. Adjustment is different, as described below.

7. To adjust rear latches (1), loosen two screws (2) that secure bracket (3) to hull top plate.
8. For carriers with flat shaped rod (4), turn clevis (5) on rod, as needed, to lengthen or shorten linkage.

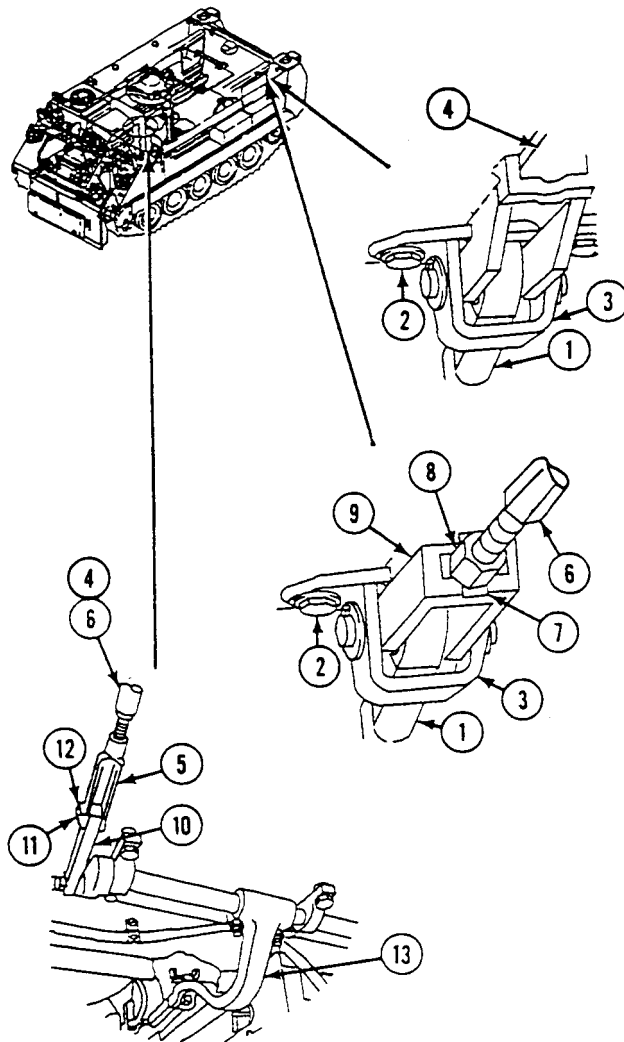
**NOTE**

Making linkage shorter pulls the ramp in and puts a tight squeeze on the ramp seal. Making linkage longer lessens the squeeze on the seal.

9. For carriers with hex shaped rod (6), bend back tabs on washer (7), loosen jam nut (8), remove rod from clevis (9), and discard washer. Install new washer, and install rod in clevis. Place link (10) in clevis (5). Secure with headed pin (11) and new cotter pin (12). Turn rod as needed to lengthen or shorten linkage. Tighten jam nut and secure by bending tabs of new washer.
10. For carriers with flat shaped rod (4), place link (10) in clevis (5). Secure with headed pin (11) and a new cotter pin (12).

ADJUST RAMP LOCK (M113A3 AND M1059A3 ONLY) — Continued**0521 00**

11. Push handle (13) in full forward position. Push bracket (3) to the rear until forward edge of slot in bracket makes contact with cam surface on latch (1).
12. Tighten two screws (2).
13. The latch (1) should point down as shown in illustration. Put your hand under latch and try to lift latch. If adjustment is right, latch will not move.
14. Move handle (13) to full released position. Latch (1) will contact rear edge of bolt in bracket (3) and will move up as shown in illustration.

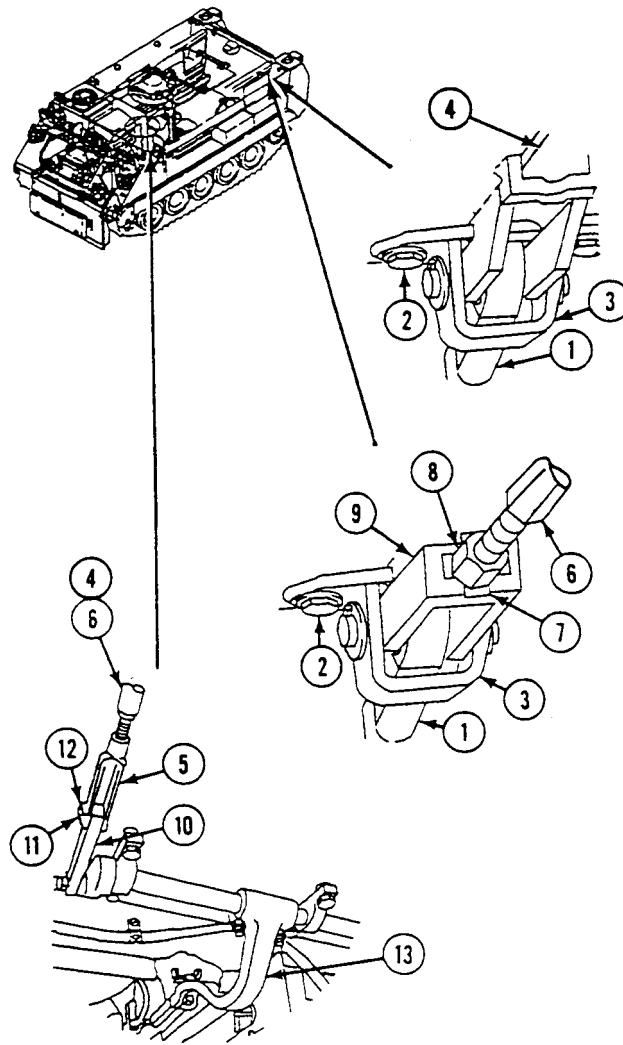

15. Wipe chalk off ramp surface and repeat seal test (Step 1).
16. If ramp fails test, check and repeat Steps 1 - 14, as needed.

END OF TASK

ADJUST RAMP LOCK (M577A3 AND M1068A3 ONLY)

0522 00

THIS WORK PACKAGE COVERS:

Adjustment (page 0522 00-1).

INITIAL SETUP:

Maintenance Level

Unit

References

See your -10

Tools and Special Tools

General Mechanic's Tool Kit (WP 0926 00, Item 65)

Equipment Condition

Engine stopped (see your -10)

Carrier blocked (see your -10)

Materials/Parts

Cotter pin (3)

Personnel Required

Unit Mechanic

Helper (H)

ADJUSTMENT

WARNING



Falling ramp could cause severe injuries. Keep personnel clear of ramp area.

1. Lower ramp (see your -10).
2. Latch ramp lock lever (1) with ramp down.
3. Remove cotter pin (2) and headed pin (3) from clevis (4) at arm (5). Discard cotter pin.
4. Loosen locknut (6) on clevis (7).

5. Remove cotter pin (8) and headed pin (9) from clevis (7) and arm (10). Discard cotter pin.

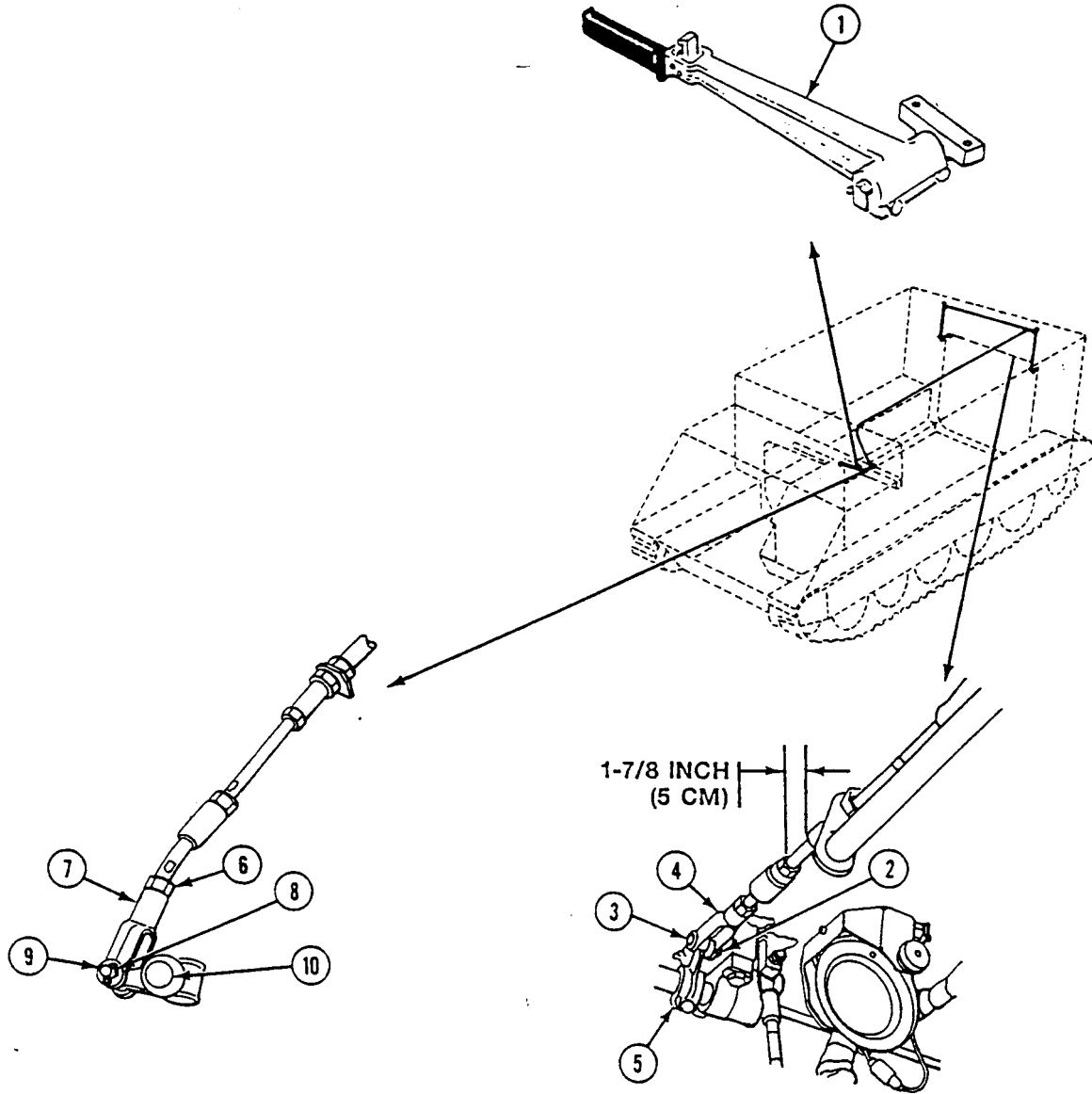

- Loosen locknuts (1) on both sides of the vehicle.

CAUTION

Insure proper thread engagement after clevis adjustment. Thread engagement should be at least 1-1/2 times diameter of rod.

NOTE

Setscrew must be adjusted so the center of the top arm is offset toward front of vehicle in reference to the center of rod.

- Adjust two setscrews (2) and rotate arm (3) until center line of arm (3) is aligned with center line of rod (4). Continue to rotate arm (3) until it is tilted 1/8 inch (3 mm) past center in reference to rod (4) toward front of vehicle.
- Tighten locknut (1) on setscrew (2).

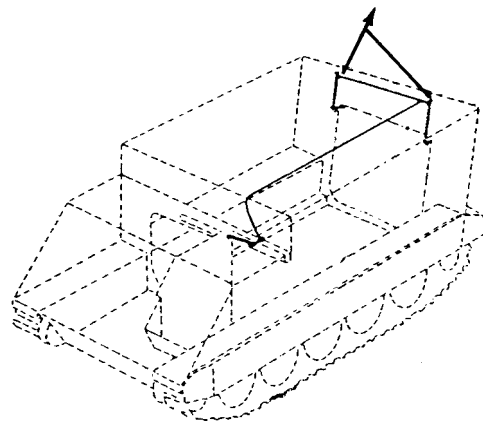
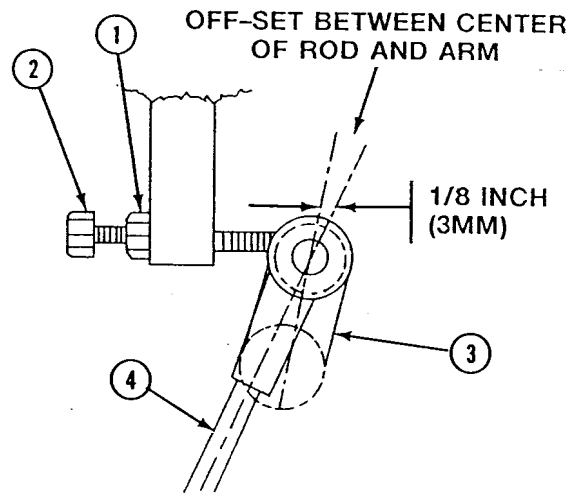

NOTE

After attaching clevis to the arm, make sure arm (3) is still against the setscrews.

9. Align clevis (5) with arm (6). Secure with headed pin (7) and new cotter pin (8).
10. Loosen two nuts (9) on cable (10) at bracket (11).
11. Adjust length of cable (10) to obtain 1-7/8 inches (5 cm) clearance between nut (12) and seal (13). Tighten two nuts (9).

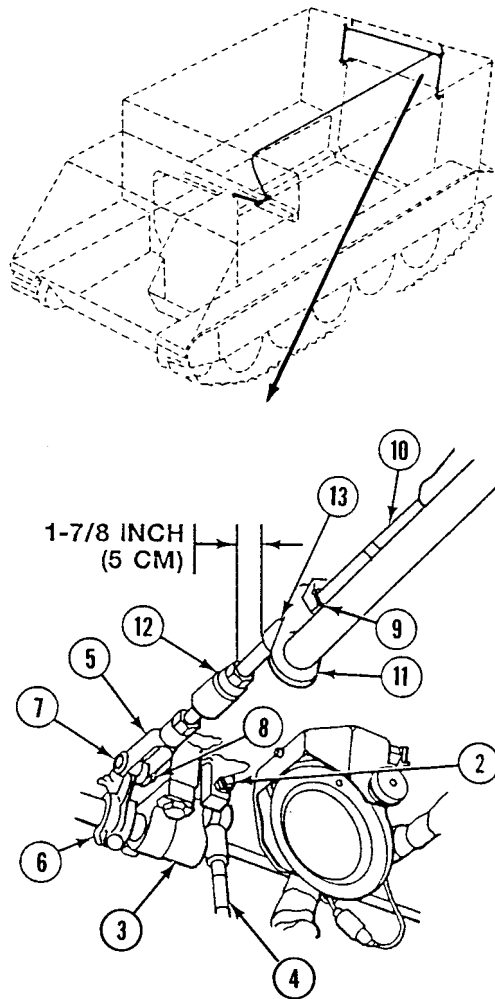

12. With ramp lock lever (1) remaining in locked position, adjust clevis (2) 3/16 inch (5 mm) short of pin (4) fitting freely with arm (3).
13. Release lever (1) and align clevis (2) with arm (3). Secure with headed pin (4) and new cotter pin (5). Tighten locknut (6).
14. Loosen two nuts (7) on lever (1) and move arm (3) to obtain 3/8 inch (10 mm) clearance between end of clevis (2) and bulkhead. Tighten nuts (7).
15. Raise and lock ramp (see your -10).

NOTE

Ramp seal should be compressed enough to prevent water leakage, yet without metal-to-metal contact between ramp and hull. Make linkage shorter to compress seal more. Make linkage longer to compress seal less.

16. Check ramp for proper seal. Stand inside the vehicle with ramp up. Insert a thick piece of paper or inspection tag between ramp (8) and hull (9). The paper should slide freely around edge with no metal to metal contact. If ramp is too tight or too loose, repeat Steps 1 - 16.

17. With ramp up, release lock lever (1).

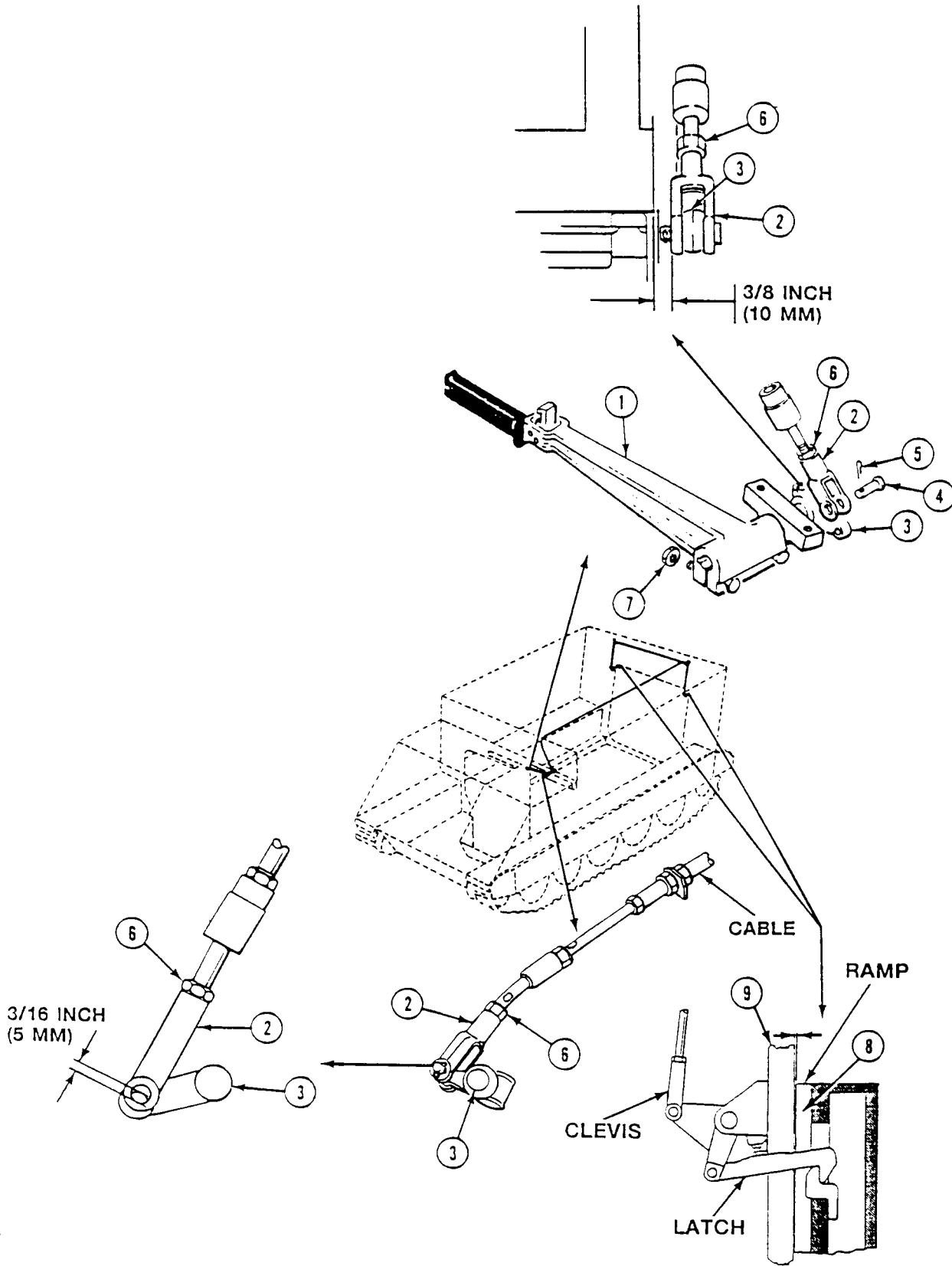

ADJUST RAMP LOCK (M577A3 AND M1068A3 ONLY) — Continued

0522 00

18. Remove cotter pin (1), headed pin (2), and clevis (3) from lever (4) for one side of vehicle only. Discard cotter pin.
19. Adjust clevis (3) to lengthen or shorten linkage and obtain a water tight seal between ramp (5) and hull (6). Latches (7) must pull tight on catches (8).
20. Align clevis (3) with lever (4). Secure with headed pin (2).
21. Latch ramp lock lever (9).
22. Check for adequate tension on ramp latch (7) and catch (8). There should be no free play in latches (7) when ramp lock lever (9) is latched.
23. Repeat Steps 17 - 22 until latch (7) is under proper tension. Install new cotter pin (1) in headed pin (2).
24. Repeat Steps 17 - 23 for latch (7) on opposite side of vehicle.
25. With ramp up and locked, loosen locknuts (10) on setscrew (11). Adjust setscrews (11) to obtain 1/16 inch (2 mm) to 3/32 inch (3 mm) maximum clearance between latches (7) and setscrews (11)

26. Tighten locknut (10) on setscrew (11).

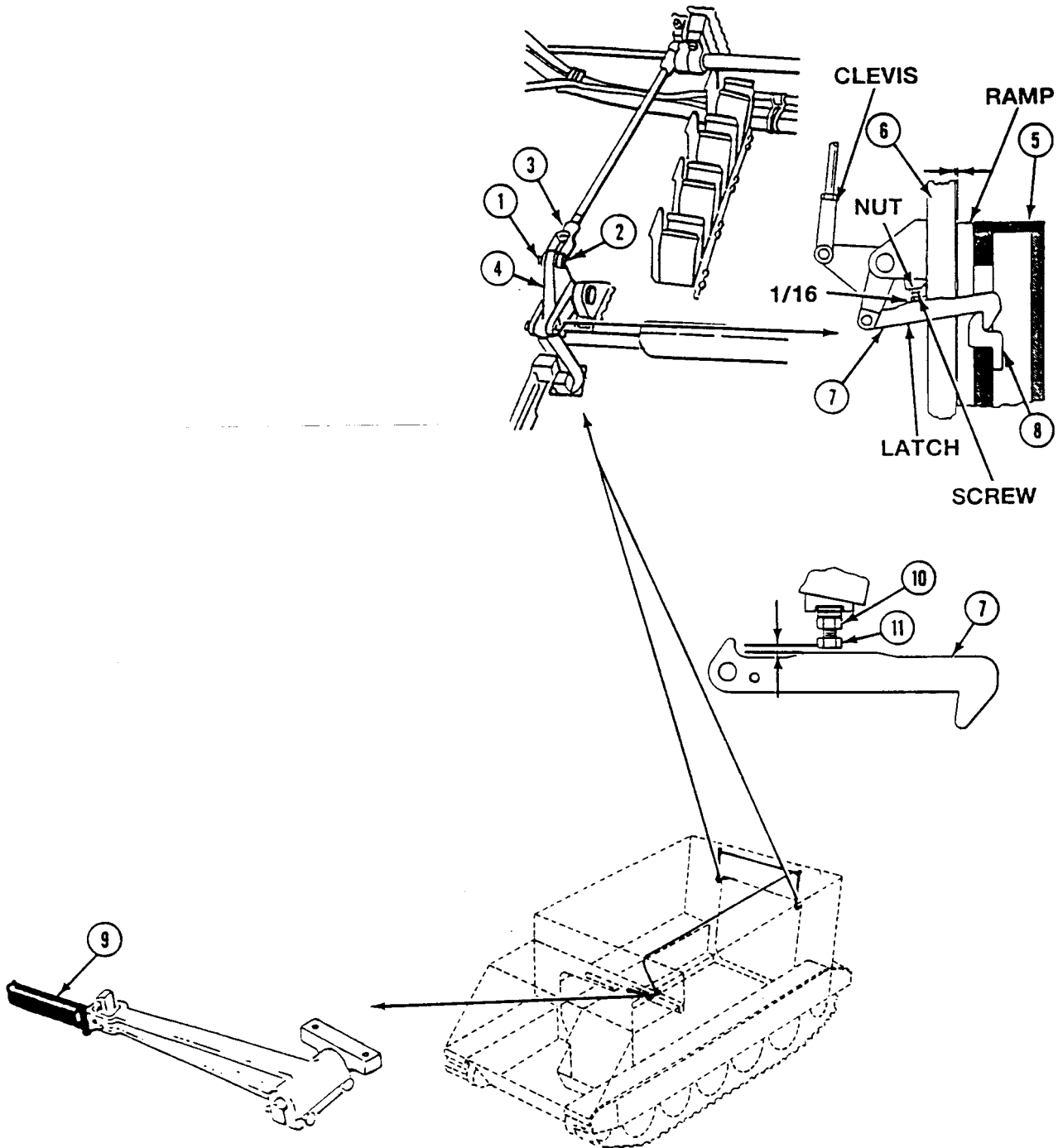

FOLLOW-THROUGH STEPS

WARNING



Falling ramp could cause severe injuries. Keep personnel clear of ramp area.

1. Perform ramp lock test (WP 0521 00).
2. Perform ramp seal test (WP 0521 00).

END OF TASK

ADJUST RAMP LOCK (M1064A3 ONLY)

0523 00

THIS WORK PACKAGE COVERS:

Adjustment (page 0523 00-1).

INITIAL SETUP:

Maintenance Level

Unit

Personnel Required

Unit Mechanic
Helper (H)

Tools and Special Tools

General Mechanic's Tool Kit (WP 0926 00, Item 65)

References

See your -10

Materials/Parts

Cotter pin
Flat steel washer (as needed)
Key washer (8)
Lockwasher (2)

Equipment Condition

Engine stopped (see your -10)
Carrier blocked (see your -10)

ADJUSTMENT

WARNING



Falling ramp could cause severe injuries. Keep personnel clear of ramp area.

1. Lower ramp (see your -10).
2. Remove cotter pin (1) and headed pin (2) from clevis (3). Discard cotter pin.
3. Disconnect link (4) from clevis (3).
4. Swing lever (5) forward. If catch (6) does not engage with striker (7), adjust catch (Step 5). If catch and striker adjustment is all right, go to Step 7.

NOTE

Install the same number of flat washers (8) on each side of all four supports (9).

5. To adjust catch (6) and striker (7), remove eight screws (10) and key washers (11) from four supports (9). Discard key washers. Install new flat washers (8) to shim between supports (9) and hull top plate.

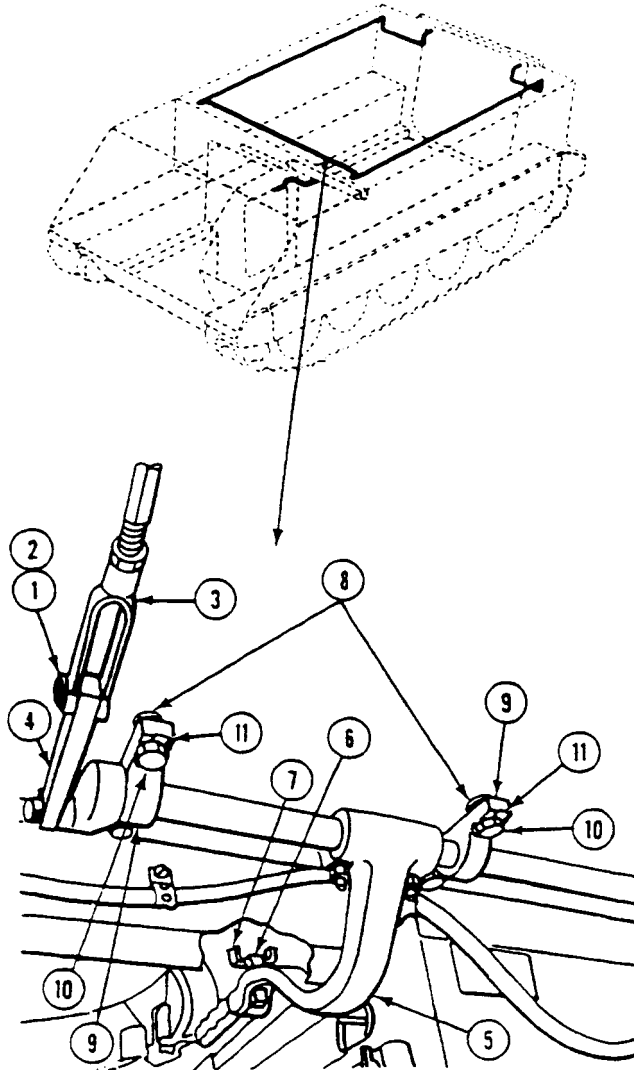

6. Install eight new key washers (1). Tighten eight screws (2) and bend washer keys to secure screws. If shimmed right, catch (3) on lever (4) will engage firmly with striker (5).
7. For carriers with flat shaped rod (6), place link (7) in clevis (8). Secure with headed pin (9) and a new cotter pin (10).
8. Start engine (see your -10).
9. Raise and lock ramp (see your -10).
10. Stop engine (see your -10).

NOTE

The steps below are for one side of ramp lock adjustment. Adjust both sides of carrier at the same time.

11. Loosen locknut (11) on forward clevis (8).

NOTE

Making linkage shorter pulls the ramp in and puts a tight squeeze on the ramp seal. Making linkage longer lessens the squeeze on the seal.

12. Turn rod (6), as needed, to make sure ramp seal is compressed right. Tighten locknut (11) on clevis (8).
13. Lower ramp (see your -10). Return lever (4) to closed position.
14. Remove two screws (12) and lockwashers (13) from trip plate (14). Discard lockwashers.

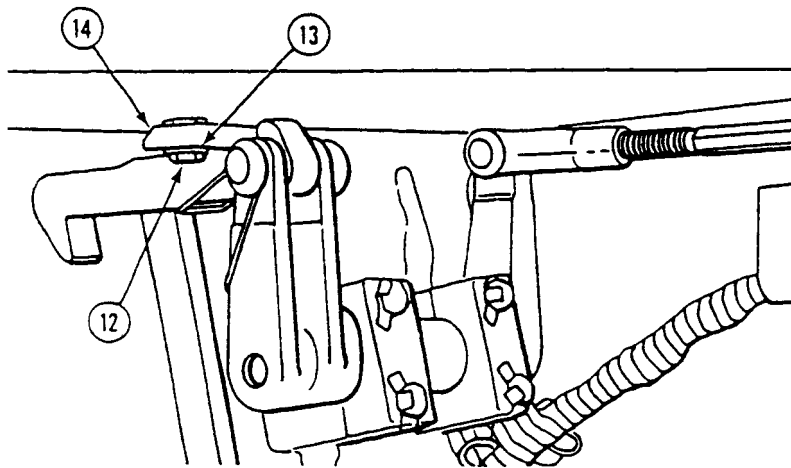
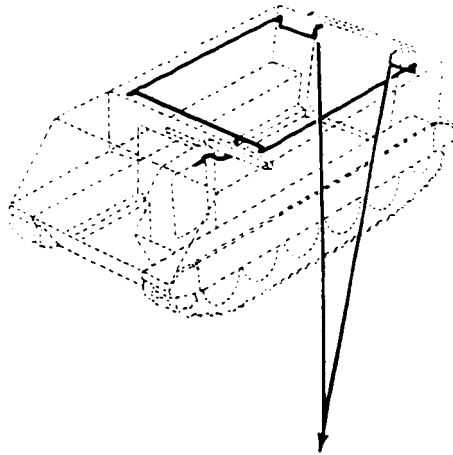
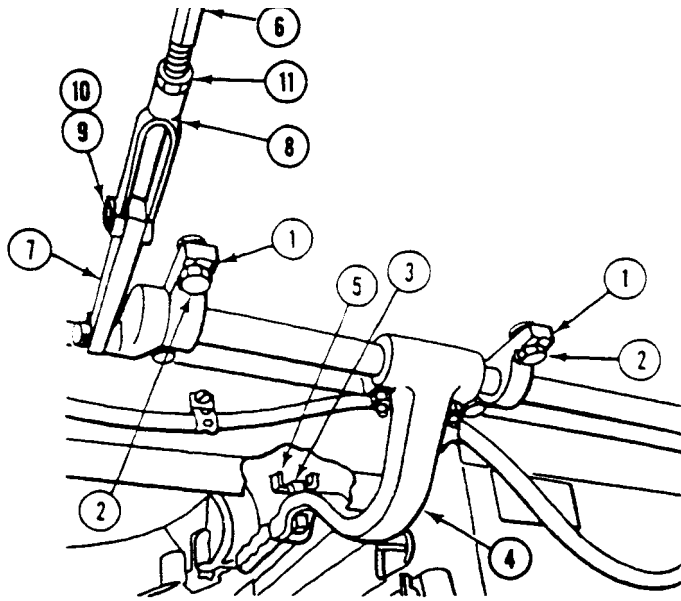

ADJUST RAMP LOCK (M1064A3 ONLY) — Continued

0523 00

15. Add or remove flat steel washers (1) between ramp trip plates (2) and hull top plate. Use same number of washers as shims on each side of trip plate. Install two new lockwashers (3) and screws (4) in trip plate (2). Do not tighten screws at this time.
16. Measure distance between trip plates (2) and latch (5). It should be 1/16 inch (2 mm) maximum. Add or delete flat steel washers (1) until this clearance is obtained.
17. Start engine (see your -10).
18. Raise and lock ramp (see your -10).
19. Stop engine (see your -10).
20. Check both trip plates (2) to see that they bear against top of latches (5).
21. Check that latch (5) and catch (6) are firm and flush against each other.
22. Lower ramp (see your -10). Adjust trip plates (2). Slide plates forward or rearward until latches (5) open, both at the same time, when ramp lock lever is pulled all the way to the rear. Latches (5) should raise up to clear catch. Tighten two screws (4).
23. If latches (5) do not raise when trip plates (2) are adjusted correctly, replace spring (7) (WP 0528 00).

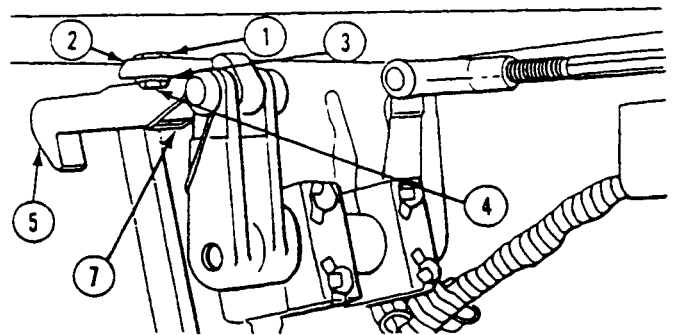
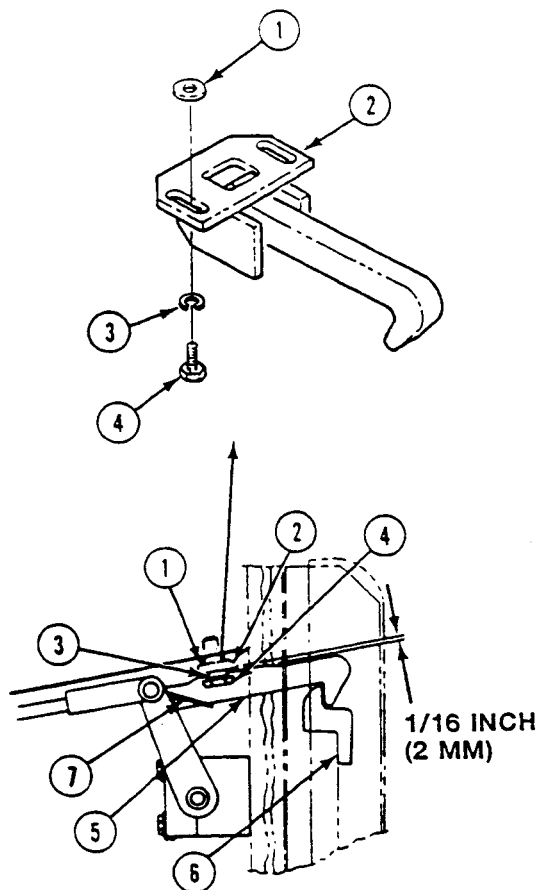

FOLLOW-THROUGH STEPS

WARNING



Falling ramp could cause severe injuries. Keep personnel clear of ramp area.

1. Perform lock test (WP 0521 00).
2. Perform seal test (WP 0521 00).

END OF TASK

REPLACE RAMP LOCK HANDLE AND ARMS (ALL EXCEPT M577A3 AND M1068A3)

0524 00

THIS WORK PACKAGE COVERS:

Removal (page 0524 00-1).
 Installation (page 0524 00-3).

INITIAL SETUP:

Maintenance Level

Unit

Personnel Required

Unit Mechanic

Tools and Special Tools

General Mechanic's Tool Kit (WP 0926 00, Item 65)

References

See your -10

Materials/Parts

Cotter pin (2)
 Key washer (8)

Equipment Condition

Engine stopped (see your -10)
 Carrier blocked (see your -10)
 Ramp lowered (see your -10)

REMOVAL

1. Remove two cotter pins (1), headed pins (2), and connecting links (3) from arms (4) and (5). Discard cotter pins.

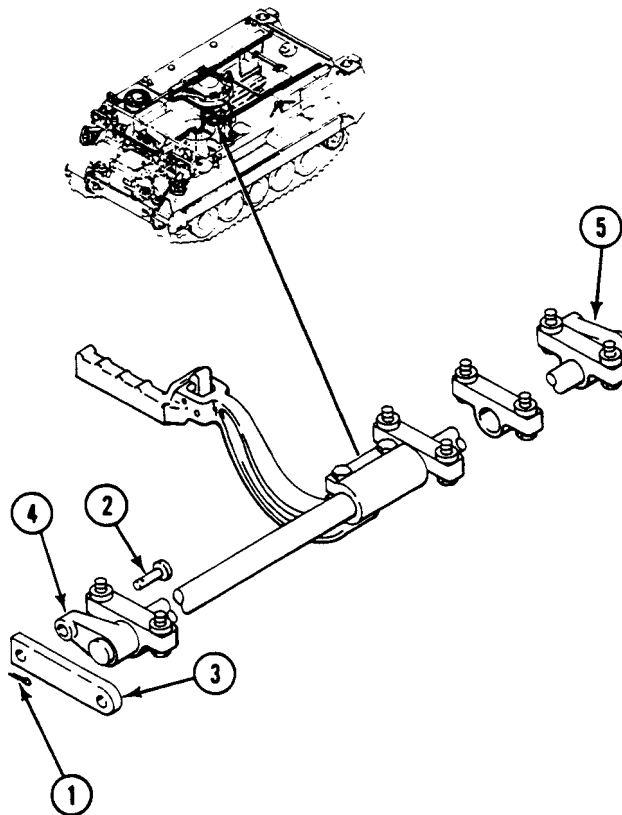

2. Note the number and location of steel washers (6) used as shims between supports (7) and top plate.

REPLACE RAMP LOCK HANDLE AND ARMS (ALL EXCEPT M577A3 AND M1068A3) —
Continued

0524 00

3. Bend back keys. Remove eight screws (8), key washers (9), four supports (7), and eight steel washers (6). Discard key washers.

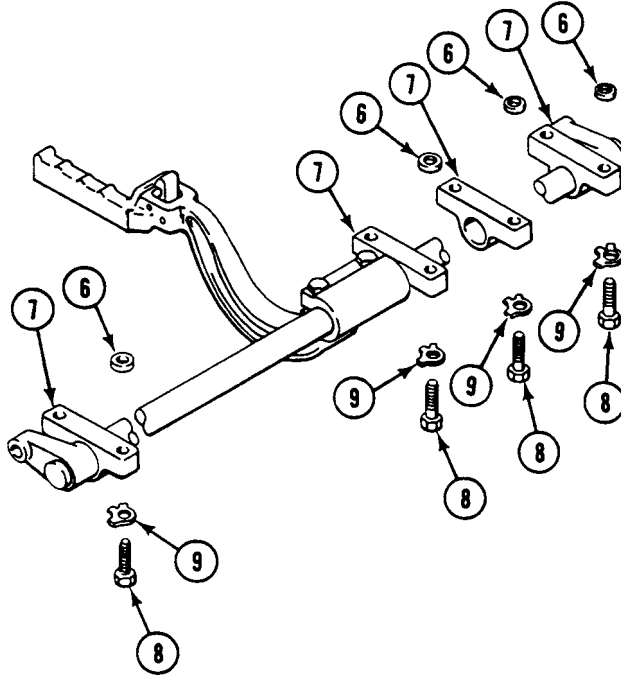

4. Remove two screws (1), washers (2), and nuts (3) from ramp lock handle (4).
5. Remove arms (5) and (6) from handle (4).
6. Remove two keys (7) from arms (5) and (6). Remove supports (8) from arms.
7. Remove two pins (9), spring (10), and catch (11) from handle (4).

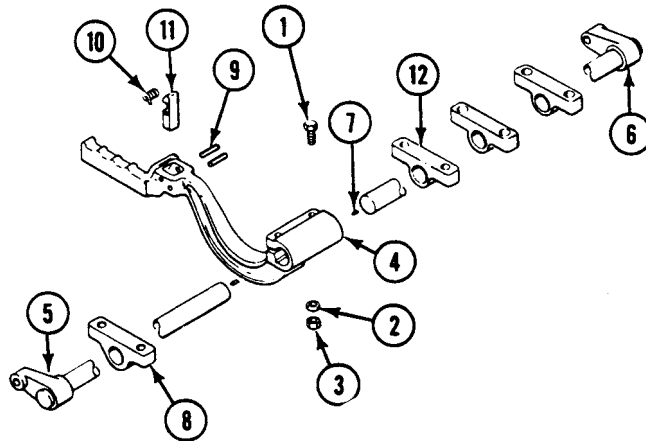

REPLACE RAMP LOCK HANDLE AND ARMS (ALL EXCEPT M577A3 AND M1068A3) —
Continued

0524 00

INSTALLATION

1. Install catch (11) and spring (10) in ramp lock handle (4). Secure with two pins (9).
2. Install one support (8) on arm (5) and three supports (12) on arm (6).
3. Install two keys (7) in arms (5) and (6).
4. Install arms (5) and (6) in handle (4). Secure with two screws (1), washers (2), and nuts (3).

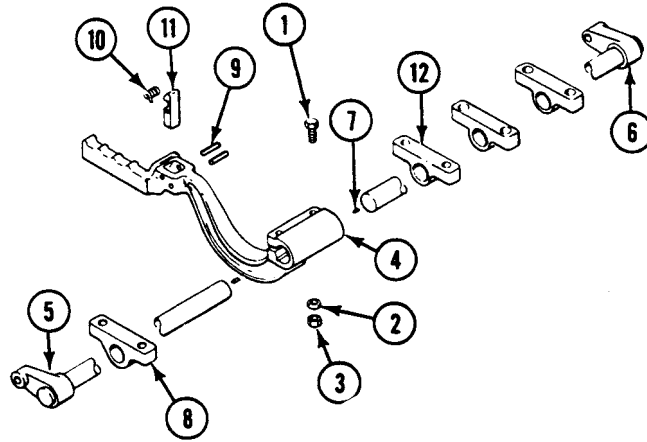

5. Align four supports (13) with holes in hull top plate. Shim with steel washers (14). Make sure you put the same number of steel washers in same position from which they were removed.
6. Secure with eight new key washers (15) and screws (16). Bend keys on washers to secure screws.

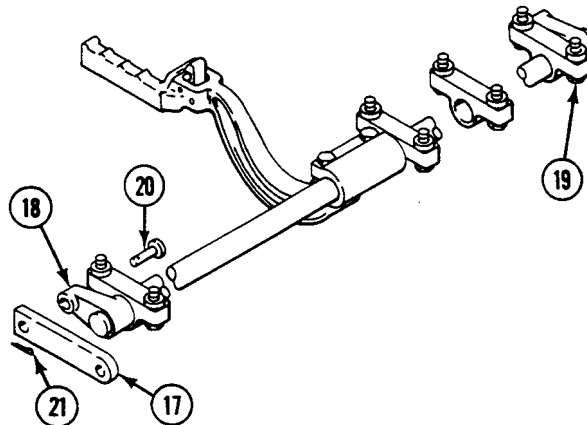

REPLACE RAMP LOCK HANDLE AND ARMS (ALL EXCEPT M577A3 AND M1068A3) —
Continued

0524 00

7. Align two connecting links (17) with two arms (18) and (19). Secure with two headed pins (20) and new cotter pins (21).

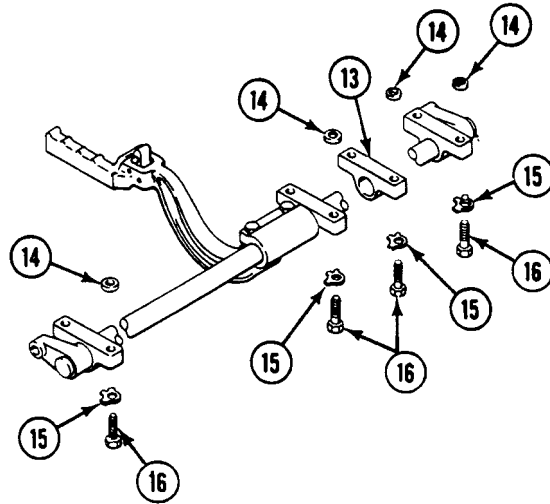
**FOLLOW-THROUGH STEPS**

1. Raise and lock ramp to check that ramp lock linkage works right (see your -10).
2. Adjust ramp lock linkage, if needed (WP 0521 00) or (WP 0523 00).

END OF TASK

REPLACE RAMP LOCK LEVER AND CABLE (M577A3 AND M1068A3 ONLY)

0525 00

THIS WORK PACKAGE COVERS:

- Removal (page 0525 00-1).
 - Cleaning, Inspection, and Repair (page 0525 00-3).
 - Installation (page 0525 00-3).
-

INITIAL SETUP:

Maintenance Level

Unit

Personnel Required

Unit Mechanic

Tools and Special Tools

General Mechanic's Tool Kit (WP 0926 00, Item 65)

References

See your -10

Materials/Parts

- Cotter pin (2)
- Key washer (4)
- Locknut (4)
- Locknut (2)
- Lockwasher
- Spring pin (2)

Equipment Condition

- Engine stopped (see your -10)
 - Carrier blocked (see your -10)
 - Ramp lowered (see your -10)
-

REMOVAL

1. Remove two cotter pins (1), headed pins (2), and clevises (3) from arms (4) and (5). Discard cotter pins.
2. Remove two locknuts (6), washers (7), and screws (8) from lever (9). Discard locknuts.
3. Bend back tabs on key washers. Remove four screws (10), key washers (11), and lever assembly (9) from hull top plate. Discard key washers.
4. Remove front support (12), lever (9), key (13), and rear support (12) from arm (4). Remove arm from bulkhead.
5. Remove two spring pins (14), catch (15), and spring (16) from lever (9). Discard spring pins.

REPLACE RAMP LOCK LEVER AND CABLE (M577A3 AND M1068A3 ONLY) —
Continued

0525 00

6. Loosen two locknuts (17). Remove two clevises (3) and locknuts (17) from two joints (18). Discard locknuts.

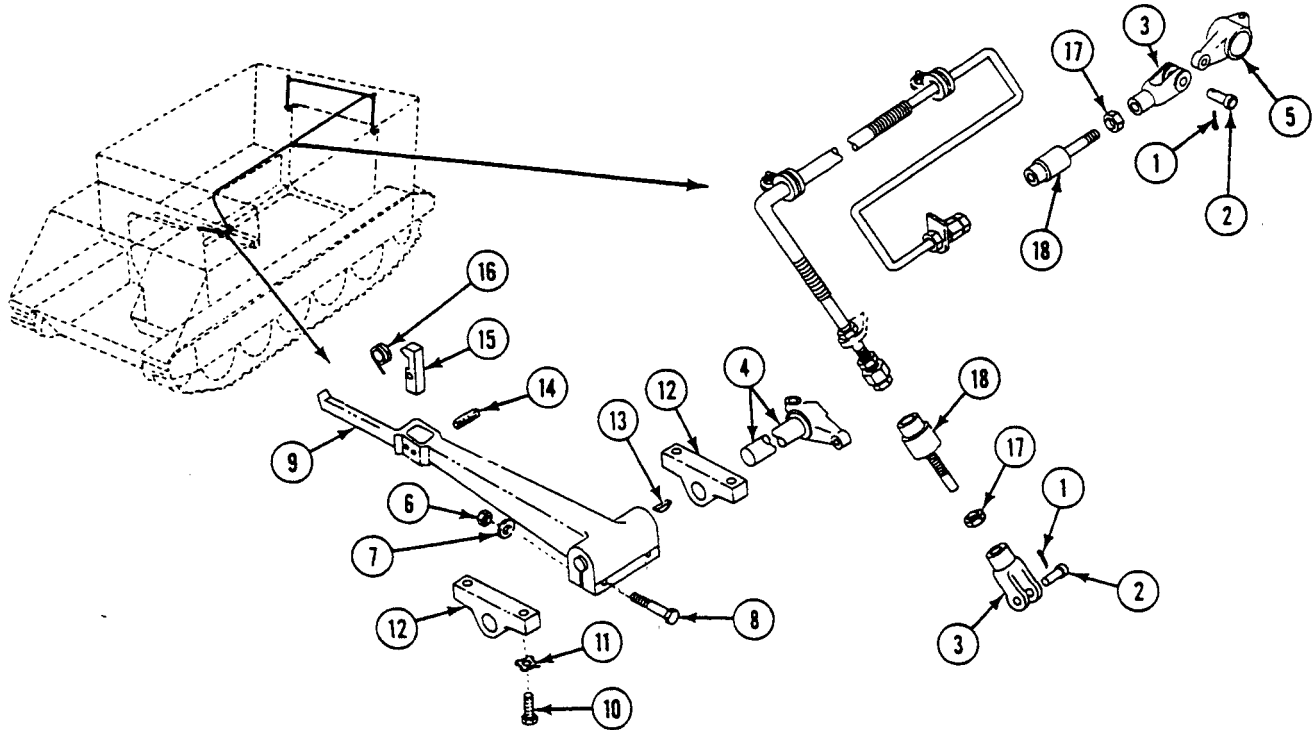

7. Loosen two locknuts (1). Remove two joints (2) and locknuts (1) from cable (3). Discard locknuts.
8. Remove two seal assemblies (4) from cable (3).
9. Remove screw (5), lockwasher (6), and clamp (7) from forward bulkhead weldnut. Discard lockwasher.
10. Remove five nuts (8), screws (9), and clamps (7) from overhead rail.
11. Remove four nuts (10) on cable (3) and on seal assemblies (4) from two hull retainers.

REPLACE RAMP LOCK LEVER AND CABLE (M577A3 AND M1068A3 ONLY) —
Continued

0525 00

12. Remove two nuts (10) and six clamps (7) from cable (3).

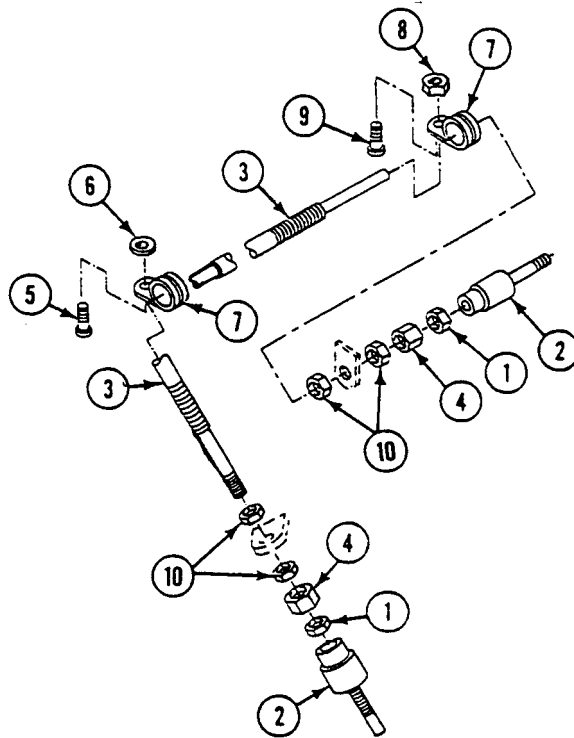

CLEANING

CLEANING, INSPECTION, AND REPAIR

1. Check cable. Replace parts that are cut, worn, binding, or have stripped threads.
2. Check ball joints. Replace joints that are binding or that have stripped threads.
3. Check ramp lock lever supports and arm. Remove scratches and grooves with fine sandpaper. Replace parts that are worn, cracked, or pitted.

INSTALLATION

1. Install six clamps (7) and four nuts (10) on cable (3).
2. Install cable (3) in two hull retainers. Secure with four nuts (10).
3. Align five clamps (7) with overhead rail. Secure with five screws (9) and nuts (8).

REPLACE RAMP LOCK LEVER AND CABLE (M577A3 AND M1068A3 ONLY) —
Continued

0525 00

4. Align clamp (7) with forward bulkhead weldnut. Secure with new lockwasher (6) and screw (5).

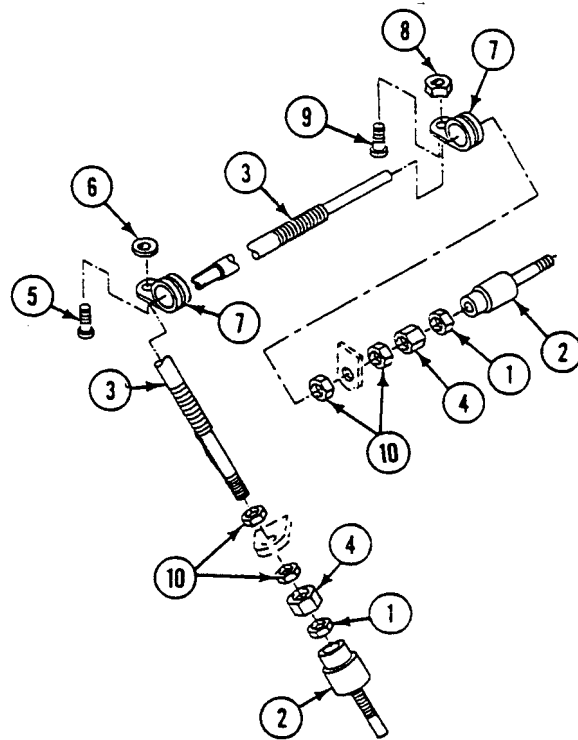

5. Install two seal assemblies (1) on cable (2).
6. Install two new locknuts (3) and joints (4) on cable (5). Secure joints with locknuts.
7. Install two new locknuts (6) and clevises (7) on two joints (4). Do not tighten locknuts.
8. Align spring (8) and catch (9) with lever (10). Secure with two new spring pins (11).
9. Position arm (12) through bulkhead. Slide rear support (13) into place.
10. Install key (14) on arm (12). Align lever (10) over key. Position front support (13) on arm.
11. Place two supports (13) on hull top plate. Secure with four new key washers (15) and screws (16), bend keys on washers to secure.
12. Install two screws (17), washers (18), and new locknuts (19) in lever (10). Do not tighten locknuts.

**REPLACE RAMP LOCK LEVER AND CABLE (M577A3 AND M1068A3 ONLY) —
Continued**

0525 00

13. Install headed pins (20) in clevises (7) and arms (12) and (21). Secure with two new cotter pins (22). Tighten locknuts (19).

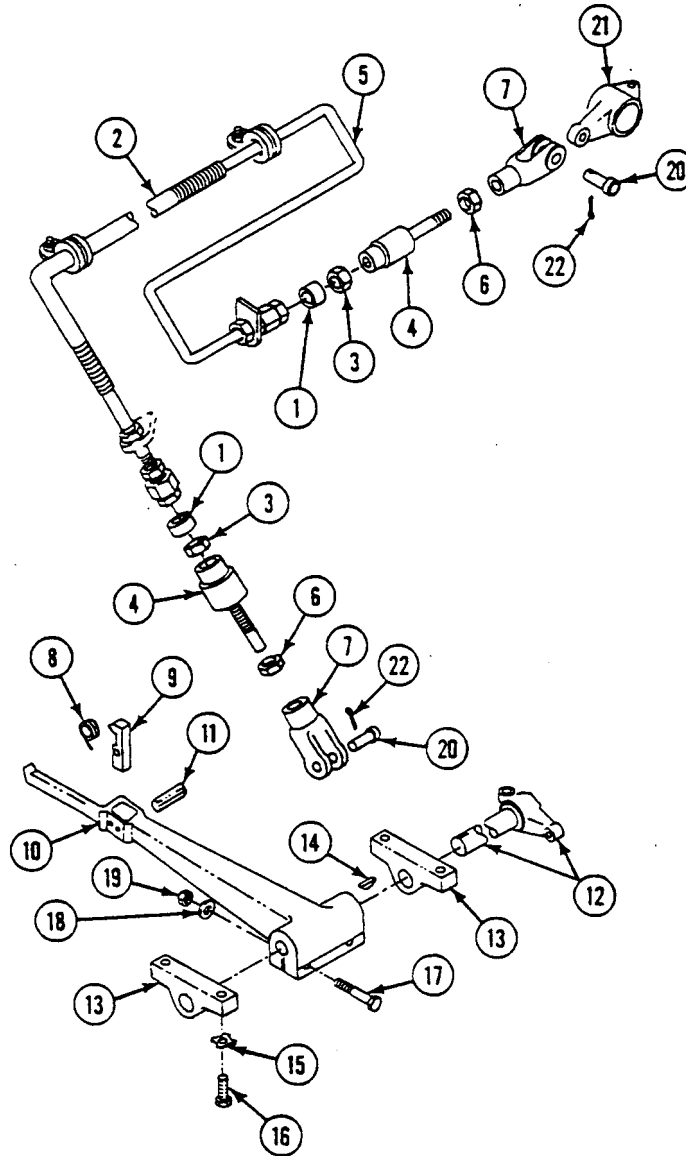

14. Adjust ramp lock (WP 0522 00).

Continued

FOLLOW-THROUGH STEPS

WARNING



Falling ramp could cause severe injuries. Keep personnel clear of ramp area.

1. Start engine (see your -10).
2. Raise and lock ramp (see your -10). Check that ramp lock lever and cable work properly.
3. Stop engine (see your -10).

END OF TASK

REPLACE RAMP LINKAGE (M113A3 AND M1059A3 ONLY)

0526 00 ■

THIS WORK PACKAGE COVERS:

Removal (page 0526 00-1).
 Installation (page 0526 00-3).

INITIAL SETUP:

Maintenance Level

Unit

Personnel Required

Unit Mechanic

Tools and Special Tools

General Mechanic's Tool Kit (WP 0926 00, Item 65)
 Torque Wrench (WP 0926 00, Item 85)

References

See your -10

Materials/Parts

Cotter pin (3)
 Key washer
 Square washer

Equipment Condition

Engine stopped (see your -10)
 Carrier blocked (see your -10)
 Ramp lowered (see your -10)

REMOVAL

NOTE

Some carriers are equipped with flat shaped ramp lock rods while other carriers are equipped with hex shaped ramp lock rods. They are removed and installed differently, as described below.

NOTE

Removal and installation of ramp linkage is the same for both sides of carrier. Text is for one side only.

1. Remove cotter pin (1), headed pin (2), and connecting link (3) from arm (4). Discard cotter pin.
2. Remove cotter pin (5), headed pin (6), and connecting link (3) from clevis (7). Discard cotter pin.

**REPLACE RAMP LINKAGE (M113A3 AND M1059A3 ONLY) —
Continued**

0526 00

NOTE

Clevis (9) and one end of hex shaped rod (10) have left-hand threads.

3. Remove clevis (7) from flat shaped rod (8), or clevis (9) from hex shaped rod (10).

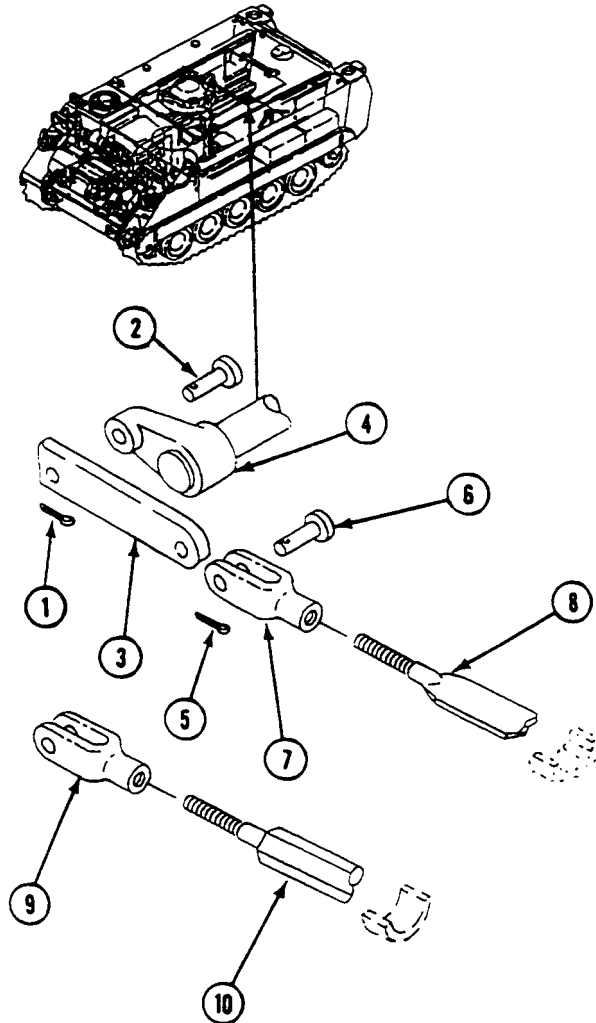

4. Remove cotter pin (1), four washers (2), headed pin (3), and latch (4). Discard cotter pin.
5. Remove two screws (5), washers (6), and bracket (7) from hull top plate.
6. Pull flat shaped rod (8) or hex shaped rod (9) from welded brackets on hull top plate. Remove three bumpers (10) as flat shaped rod is removed, or three bushings (11) as hex shaped rod is removed.
7. For hex shaped rod (9), bend back tabs on key washer (12), loosen jam nut (13), and remove clevis (14) from rod. Remove jam nut from rod and discard key washer.

REPLACE RAMP LINKAGE (M113A3 AND M1059A3 ONLY) —
Continued

0526 00

8. Bend back tab corner and remove screw (15), square washer (16), and catch (17) from ramp. Discard square washer.

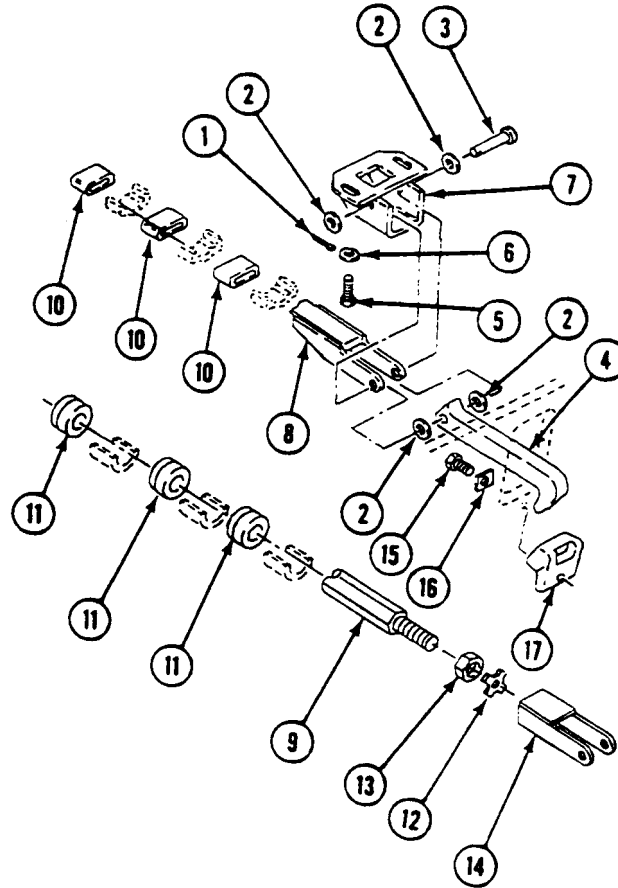

INSTALLATION

1. Place catch (17) on ramp. Secure with new square washer (16) and screw (15). **TIGHTEN SCREW TO 60-70 LB-FT (81-95 N·m) TORQUE.** Bend corner of square washer to lock screw.
2. For hex shaped rod, install nut (13), new key washer (12), and clevis (14) on right-hand threaded end of rod (9). Do not bend tabs on key washer until lock adjustment (Step 9).
3. Install flat shaped rod (8) or hex shaped rod (9) in welded brackets. As rod passes through each bracket, install three bumpers (10) on flat shaped rod (8), or three bushings (11) on hex shaped rod (9).
4. Place bracket (7) on hull top plate. Install two washers (6) and screws (5). Do not tighten screws until lock adjustment (Step 9).

**REPLACE RAMP LINKAGE (M113A3 AND M1059A3 ONLY) —
Continued**

0526 00

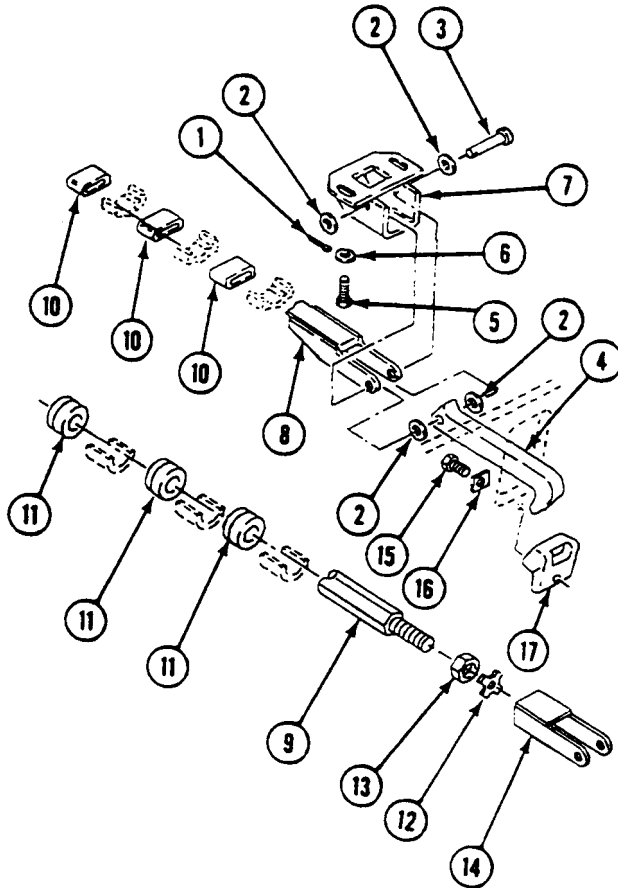
5. Align flat shaped rod (8) or hex shaped rod (9) and latch (4) in bracket (7). Secure with four washers (2), headed pin (3), and new cotter pin (1).



6. Install clevis (1) on flat shaped rod (2) or clevis (3) on left hand threaded end of hex shaped rod (4).
7. Align connecting link (5) with clevis (1) or (3). Secure with headed pin (6) and new cotter pin (7).

REPLACE RAMP LINKAGE (M113A3 AND M1059A3 ONLY) —
Continued

0526 00 ■

8. Align connecting link (5) with arm (8). Secure with headed pin (9) and new cotter pin (10).

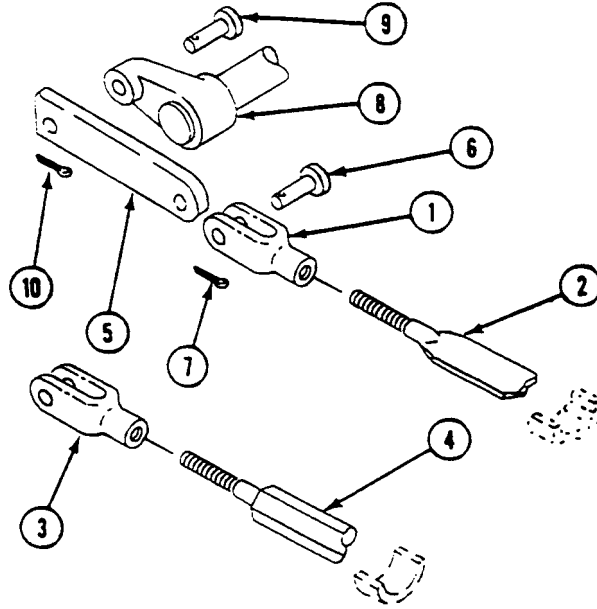

9. Adjust ramp lock (WP 0521 00).

FOLLOW-THROUGH STEPS

1. Raise and lock ramp to check that ramp linkage works right (see your -10).
2. Stop engine (see your -10).

END OF TASK

REPLACE RAMP LINKAGE (M577A3 AND M1068A3 ONLY)

0527 00

THIS WORK PACKAGE COVERS:

Removal (page 0527 00-1).
 Cleaning, Inspection, and Repair (page 0527 00-3).
 Installation (page 0527 00-3).

INITIAL SETUP:

Maintenance Level

Unit

Personnel Required

Unit Mechanic

Tools and Special Tools

General Mechanic's Tool Kit (WP 0926 00, Item 65)

References

See your -10

Materials/Parts

Cotter pin (6)
 Key washer (10)
 Locknut (4)
 Square washer

Equipment Condition

Engine stopped (see your -10)
 Carrier blocked (see your -10)
 Ramp lowered (see your -10)

REMOVAL

WARNING

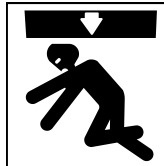

Falling ramp could cause severe injuries. Keep personnel clear of ramp area.

1. Remove cotter pin (1), headed pin (2), and clevis (3) from arm (4). Discard cotter pin.
2. Remove cotter pin (5), headed pin (6), and clevis (7) from lever (8). Discard cotter pin.
3. Remove two cotter pins (9), headed pins (10), and eyebolts (11) from arms (12) and (13). Discard cotter pins.
4. Remove eyebolt (11) from clevis (7).
5. Loosen two locknuts (14). Remove two adjusting screws (15) and locknuts from two hull brackets (16). Discard locknuts.
6. Remove eight screws (17), key washers (18), and four supports (19) with arm assembly from hull top plate. Discard key washers.
7. Remove locknut (20) and screw (21) from arm (4). Discard locknut.
8. Remove two screws (22) from connector (23).

9. Remove arm (12) from connector (23) and key (24) from arm.

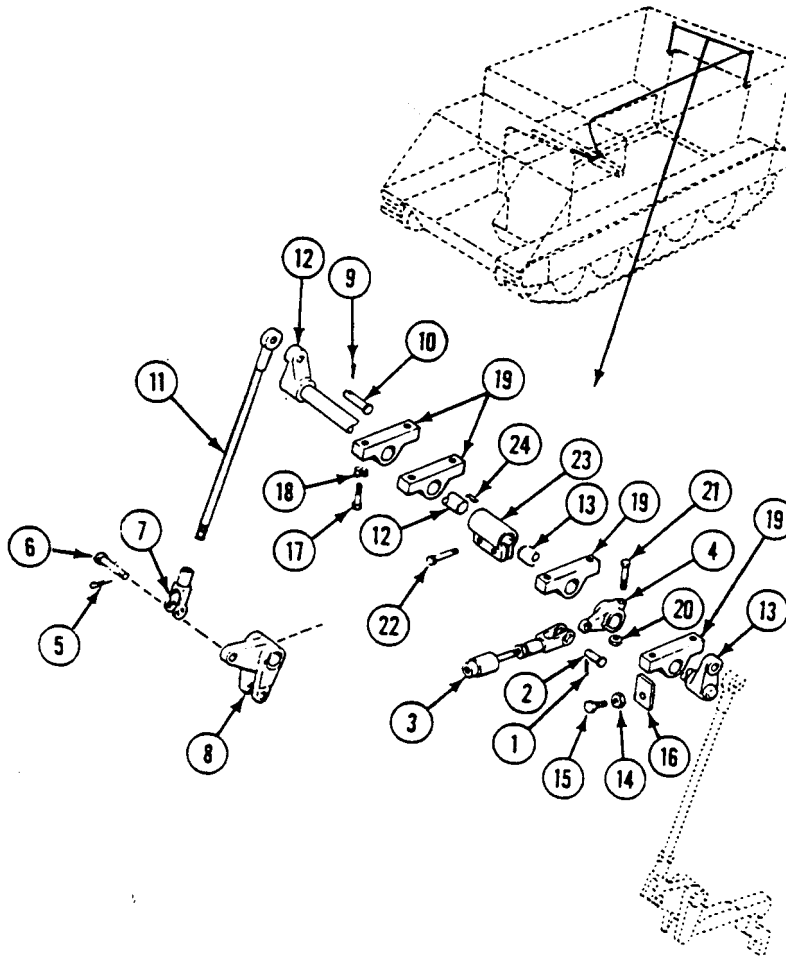

10. Remove arm (1) from connector (2) and key (3) from arm (1).

NOTE

Both sides are disassembled the same way.

11. Remove two supports (4), lever (5), and key (6) from arm (1).
12. Remove cotter pin (7), headed pin (8), and latch (9) from lever (10). Discard cotter pin.
13. Remove cotter pin (11), headed pin (12), and lever (10) from hull bracket.
14. Loosen locknut (13). Remove adjusting screw (14) and locknut from plate (15). Remove locknut from screw. Discard locknut.
15. Bend back tabs on key washers (16). Remove two screws (17), key washers (16), and plate (15) from hull bracket.
16. Bend back corner on square washer (18). Remove screw (19), square washer (18), and catch (20) from ramp. Discard square washer.

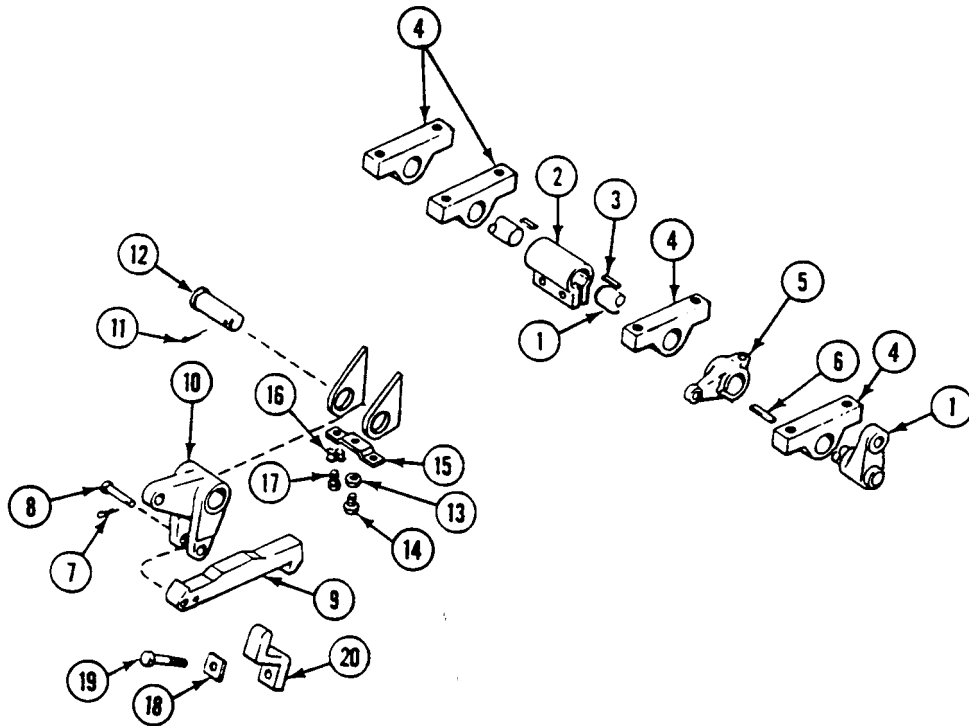

CLEANING

CLEANING, INSPECTION, AND REPAIR

1. Check arms, supports, latch, catch, and lever. Remove scratches and grooves with fine sandpaper. Replace parts that are worn or pitted.

INSTALLATION

1. Place catch (20) on ramp. Secure with new square washer (18) and screw (19). Bend corner on square washer to secure screw.

REPLACE RAMP LINKAGE (M577A3 AND M1068A3 ONLY) — Continued

0527 00

2. Place plate (15) on hull bracket. Secure with two new key washers (16) and screws (17). Bend tabs on key washers to secure screws.
3. Install new locknut (13) on adjusting screw (14). Install screw in plate (15). Do not tighten locknut.
4. Align lever (10) with hull bracket. Secure with headed pin (12) and new cotter pin (11).
5. Align latch (9) with lever (10). Secure with headed pin (8) and new cotter pin (7).

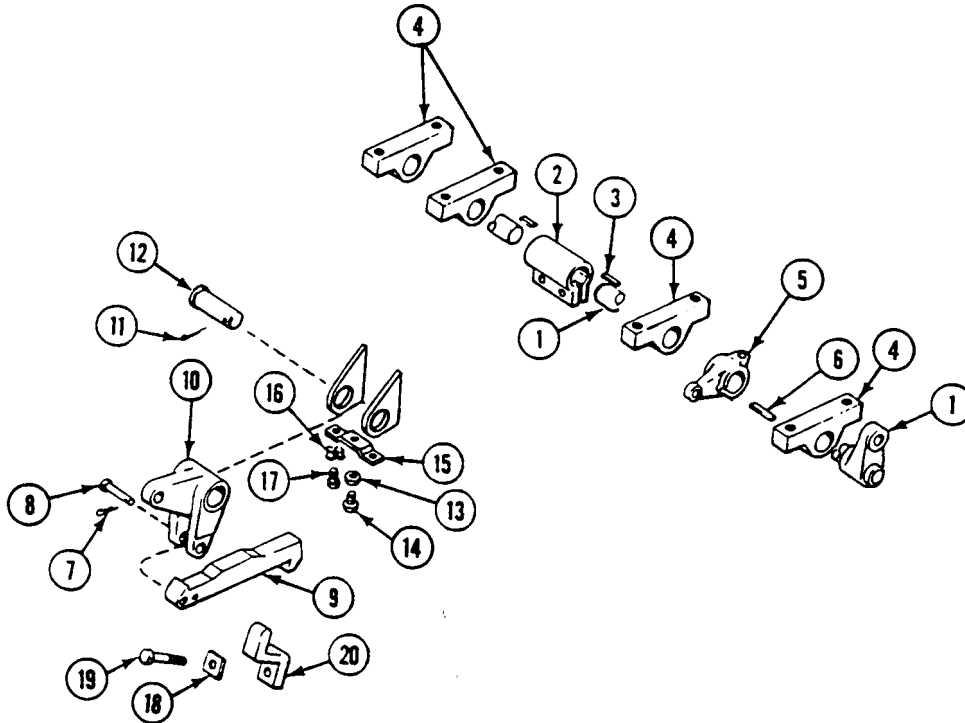

6. Install one support (1), key (2), arm (3), one support (1), and key (4) on arm (5). Install arm (5) in connector (6).
7. Secure arm (3) on arm (5) with screw (7) and new locknut (8).
8. Install two supports (1) and key (9) on arm (10).
9. Align four supports (1) with hull top plate. Secure with eight new key washers (11) and screws (12). Bend tabs on key washers to secure screws.
10. Insert arm (10) in connector (6). Install two screws (13) in connector (6). Tighten screws.
11. Install two new locknuts (14) on two screws (15). Install screws in hull brackets (16). Do not tighten locknuts.
12. Install eyebolt (17) in clevis (18).
13. Align two eyebolts (17) with arms (10) and (5). Secure with two headed pins (19) and new cotter pins (20).
14. Align clevis (18) with lever (21). Secure with headed pin (22) and new cotter pin (23).

15. Align clevis (24) with arm (3). Secure with headed pin (25) and new cotter pin (26).

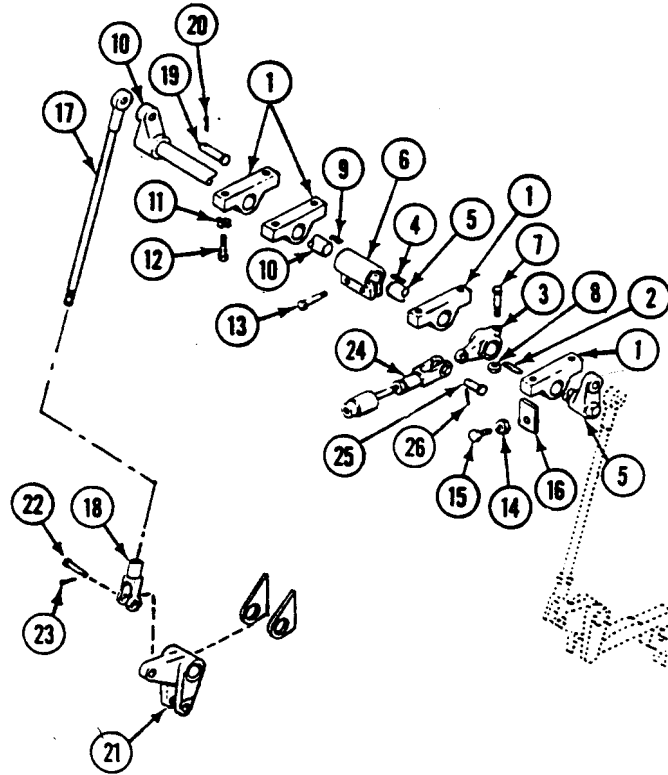

16. Tighten all locknuts.
17. Adjust ramp lock (WP 0522 00).

FOLLOW-THROUGH STEPS



Falling ramp could cause severe injuries. Keep personnel clear of ramp area.

1. Start engine (see your -10).
2. Raise and lock ramp (see your -10). Check that ramp lever and cable operate properly.
3. Stop engine (see your -10).

END OF TASK

REPLACE RAMP LINKAGE (M1064A3 ONLY)

0528 00

THIS WORK PACKAGE COVERS:

- Removal (page 0528 00-1).
- Cleaning, Inspection, and Repair (page 0528 00-3).
- Installation (page 0528 00-3).

INITIAL SETUP:

Maintenance Level

Unit

Personnel Required

Unit Mechanic

Tools and Special Tools

General Mechanic's Tool Kit (WP 0926 00, Item 65)

References

See your -10

Materials/Parts

- Cotter pin (8)
- Key washer (8)
- Locknut
- Lockwasher (2)
- Square washer (2)

Equipment Condition

- Engine stopped (see your -10)
 - Carrier blocked (see your -10)
 - Ramp lowered (see your -10)
 - Ammunition racks removed as needed (WP 0606 00) or (WP 0608 00)
-

REMOVAL

NOTE

Removal and installation of ramp linkage is the same for both sides of carrier. Text is for one side only.

1. Remove cotter pin (1), headed pin (2), and connecting link (3) from arm (4). Discard cotter pin.
2. Remove cotter pin (5), headed pin (6), and connecting link (3) from clevis (7). Discard cotter pin.

3. Loosen locknut (8). Remove clevis (7) and locknut from rod (9). Discard locknut.

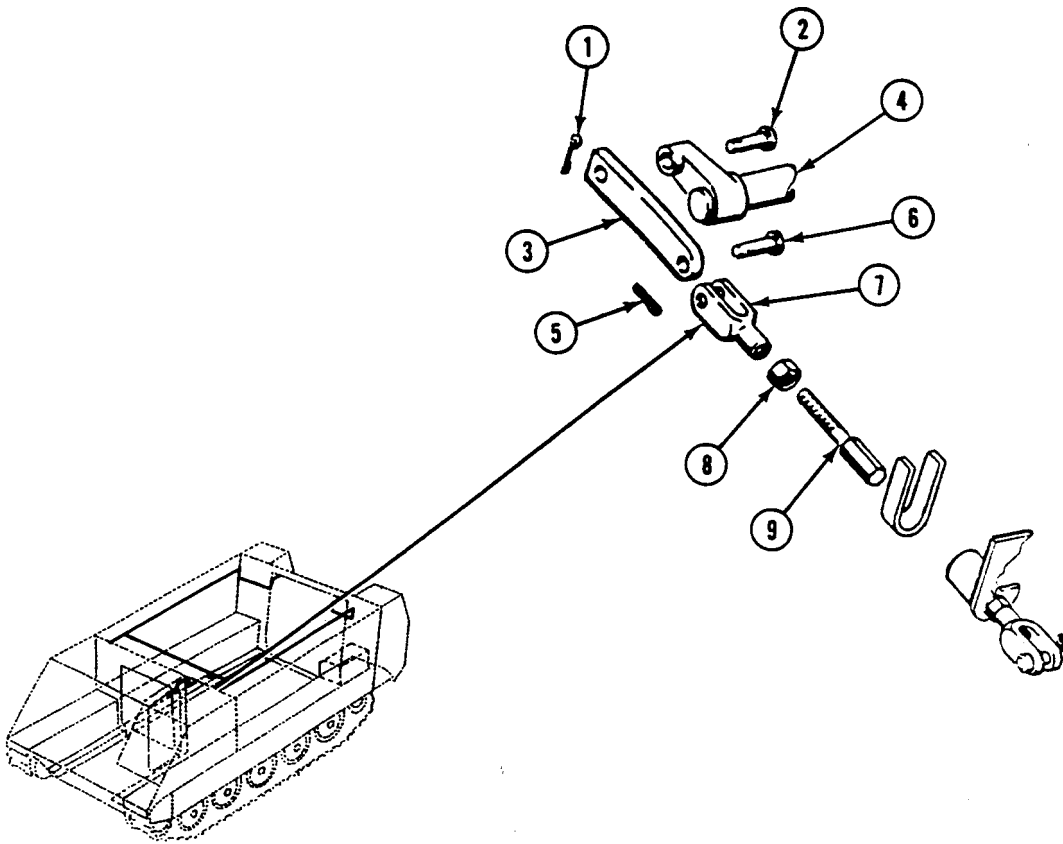

4. Remove cotter pin (1), headed pin (2), and clevis (3) from cross-shaft arm (4). Discard cotter pin.
5. Remove clevis (3) from rod (5).
6. Remove rod (5) and three bumpers (6) from carrier.
7. Remove three bumpers (6) from rod (5) as rod is pulled from carrier.
8. Remove cotter pin (7), headed pin (8), spring (9), two washers (10), and latch (11) from cross shaft arm (4). Discard cotter pin.
9. Remove pin (12) from latch (11).
10. Bend back keys. Remove four screws (13), key washers (14), two support blocks (15), and arm (4) from rear bulkhead. Discard key washers.
11. Remove two screws (16), lockwashers (17), washers (18), trip plate (19), and washers (20) from hull top plate. Note position and number of washers removed. Discard lockwashers.

REPLACE RAMP LINKAGE (M1064A3 ONLY) — Continued**0528 00**

12. Bend back key corner and remove screw (21), square washer (22), and catch (23) from ramp. Discard square washer.

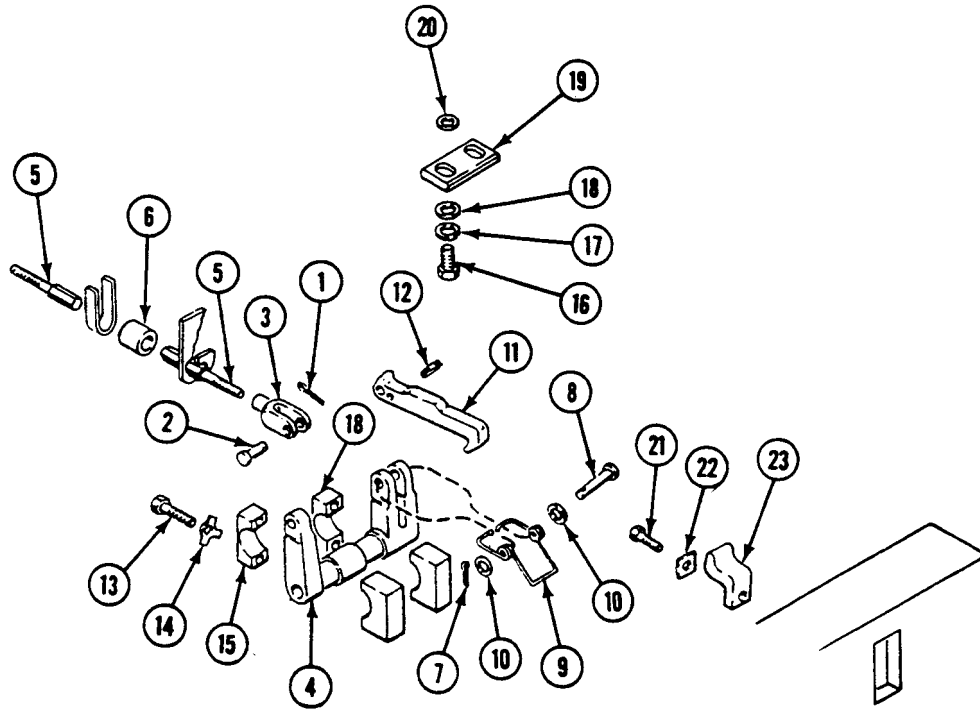
**REPAIR OR REPLACEMENT****INSPECTION AND REPAIR**

1. Check rods. Replace rod that is bent, damaged, or has stripped threads.
2. Check bumpers. Replace bumpers that are cracked, torn, or not flexible.
3. Check support blocks. Replace blocks that are worn or binding.
4. Check cross-shaft arm. Remove grooves and scratches with fine sandpaper. Replace worn or pitted arm.
5. Check catch and latch. Replace damaged catch or latch.

INSTALLATION

1. Place catch (23) on ramp. Secure with new square washer (22) and screw (21). Bend corner on washer to secure screw.

REPLACE RAMP LINKAGE (M1064A3 ONLY) — Continued

0528 00

2. Place washers (20) and trip plate (19) on hull top plate. Make sure you install the same number of washers (20) in same positions from which they were removed. Secure with two washers (18), new lockwashers (17), and screws (16). Do not tighten screws until lock adjustment (Step 13).

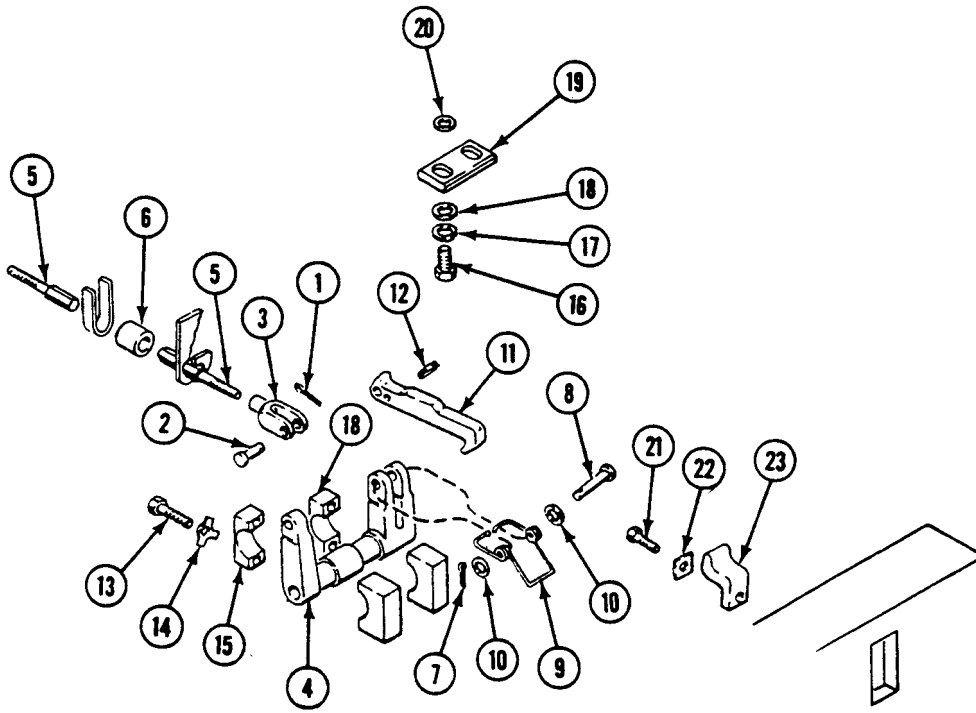

3. Place cross-shaft arm (1) on rear bulkhead. Secure with two support blocks (2), four new key washers (3), and screws (4). Bend keys to secure screws.
4. Install pin (5) in latch (6).
5. Align spring (7), latch (6), and two washers (8) with arm (1). Secure with headed pin (9) and new cotter pin (10).
6. Install three bumpers (11) on rod (12).
7. Install rod (12) and three bumpers (11) in carrier.
8. Install clevis (13) on rod (12).
9. Align clevis (13) with arm (1). Secure with headed pin (14) and new cotter pin (15).
10. Install new locknut (16) and clevis (17) on rod (12). Do not tighten locknut until lock adjustment (Step 13).
11. Align connecting link (18) with clevis (17). Secure with headed pin (19) and new cotter pin (20). Do not bend ends of cotter pin until lock adjustment (Step 13).

12. Align connecting link (18) with arm (21). Secure with headed pin (22) and new cotter pin (23).

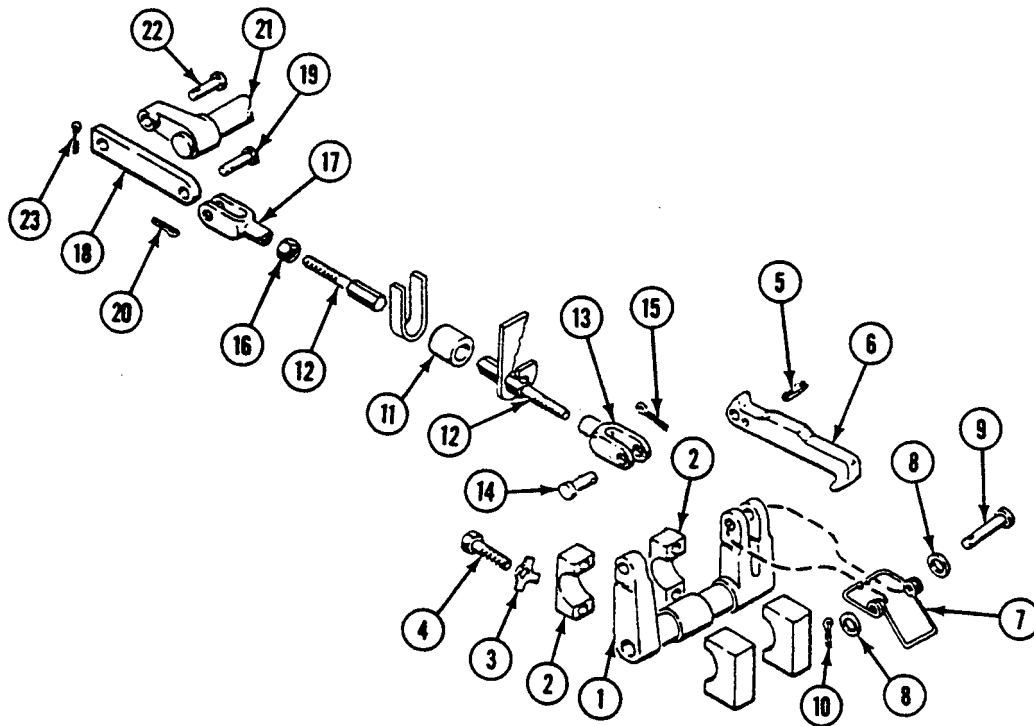

13. Adjust ramp lock (WP 0523 00).

FOLLOW-THROUGH STEPS

WARNING

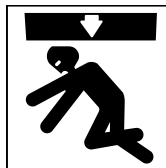

Falling ramp could cause severe injuries. Keep personnel clear of ramp area.

1. Install ammunition racks that were removed (WP 0606 00) or (WP 0608 00).
2. Start engine (see your -10).
3. Raise and lock ramp to check that ramp linkage operates properly (see your -10).
4. Stop engine (see your -10).

END OF TASK

REPAIR HULL BY WELDING

0529 00

THIS WORK PACKAGE COVERS:

- Safety Precautions (page 0529 00-1).
- Aluminum Castings (page 0529 00-1).
- Magnesium Castings (page 0529 00-2).
- Fuel Tanks (page 0529 00-3).
- Plastic Molding Material (page 0529 00-3).
- Welding Near Mortar Ring (M1064A3 Only) (page 0529 00-4).
- General Welding Instructions (page 0529 00-4).
- MIG Welding Method (page 0529 00-5).

INITIAL SETUP:

Maintenance Level

Unit

References

- See your -10
- TM 9-237
- TM 43-0139

Tools and Special Tools

- Metal Worker's Tool Kit (WP 0926 00, Item 63)
- Trailer Mounted Welding Shop (WP 0926 00, Item 69)

Equipment Condition

- Engine stopped (see your -10)
- Carrier blocked (see your -10)
- Battery ground strap disconnected (WP 0337 00), (WP 0338 00), or (WP 0339 00)

Materials/Parts

- Cleaning compound (WP 0928 00, Item 19)

Personnel Required

- Metal Worker 44B10

REPAIR OR REPLACEMENT

SAFETY PRECAUTIONS

1. Wear clothing such as leather or heavy denim. Do not wear clothing with loose pockets, trouser cuffs, or short or rolled-up sleeves.
2. Do not expose bare skin to welding arc.
3. Do not look directly at welding arc unless you are wearing a welding hood.
4. Wear flash goggles or tinted safety glasses (No. 2) in welding area.
5. Disconnect power source before changing parts or making equipment repairs.
6. Do not touch drive mechanism or any part of the electrode.
7. Make sure welding area has plenty of fresh air without being drafty. Remove all toxic and combustible material.
8. Make sure all electrical and gas connections are tight.
9. Do not touch any metal in welding area with bare hands. Aluminum does not change color when hot.
10. Do not weld in the fuel compartment where sealing compound has been applied.
11. Use a welding screen to protect personnel from arc flash.

ALUMINUM CASTINGS

CAUTION

Heat distortion during welding will damage aluminum castings. Do not attempt to repair aluminum castings by welding.

1. Welding on final drive aluminum casting is not authorized. Do not attempt to weld on the final drive housing assembly.

MAGNESIUM CASTINGS

WARNING

Magnesium may catch on fire if welded on or exposed to high temperatures. Do not weld on magnesium castings or expose them to high temperatures.

1. Welding on fan magnesium castings is not authorized. Do not attempt to weld on these parts.

WARNING

Fine particles of magnesium can catch fire and burn you. Be very careful when filing or grinding on magnesium. Use grinding equipment marked FOR MAGNESIUM GRINDING ONLY. Keep a Class D fire extinguisher nearby.

2. You must observe the following safety precautions when filing or grinding on magnesium:
 - a. Use grinding equipment marked FOR MAGNESIUM GRINDING ONLY.
 - b. Use a suitable coolant when grinding magnesium to keep temperatures below ignition point.
 - c. Keep tools used on magnesium sharp.

WARNING

Water and foam-type fire extinguishers will cause magnesium fires to flare up. Use a Class D fire extinguisher or a sodium chloride base dry powder to fight magnesium fires.

- d. Keep a Class D fire extinguisher nearby for use on magnesium fires.
- e. Wear outer clothing of fire retardant cloth or leather. Brush clothing often to remove magnesium particles.
- f. Clean work area often. Do not let magnesium particles build up.

WARNING

Improper disposal of magnesium can cause a fire or explosion. Do not expose magnesium to high temperatures. Let magnesium dry before placing in sealed metal containers. Label containers and ship to a Class 1 hazardous waste disposal site.

- g. Dispose of magnesium chips and filings according to regulations.

FUEL TANKS**WARNING**

Fuel fumes can explode and burn you. Before welding:

- Drain all fuel.
 - Disconnect and cap all fuel and vent lines.
 - Purge fuel residue and fumes by steam cleaning.
 - Purge air from fuel tank with CO₂.
1. Observe the safety precautions for fuel tanks before welding.

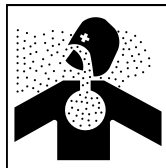
PLASTIC MOLDING MATERIAL**WARNING**

Do not weld on plastic molding material. Welding on plastic molding creates toxic fumes. Fumes are hazardous to your health and can result in death.

1. Welding on plastic molding material is not authorized. Do not attempt to weld on these parts. Replace part or notify your supervisor. The following is a list of plastic molding material parts and their locations:
 - a. Driver's power plant compartment access panel.
 - b. Power plant rear compartment access panel.

- c. Driver's seat upholstered backrest.
- d. Trim vane rear pod.
- e. Trim vane front pod.
- f. All armor made of plastic molding material.

WELDING NEAR MORTAR RING (M1064A3 ONLY)**CAUTION**

Welding on area around mortar ring will cause turntable to bind.

1. Do not weld on M1064A3 carriers in the area around mortar ring. The area extends from top of hull right through hull.

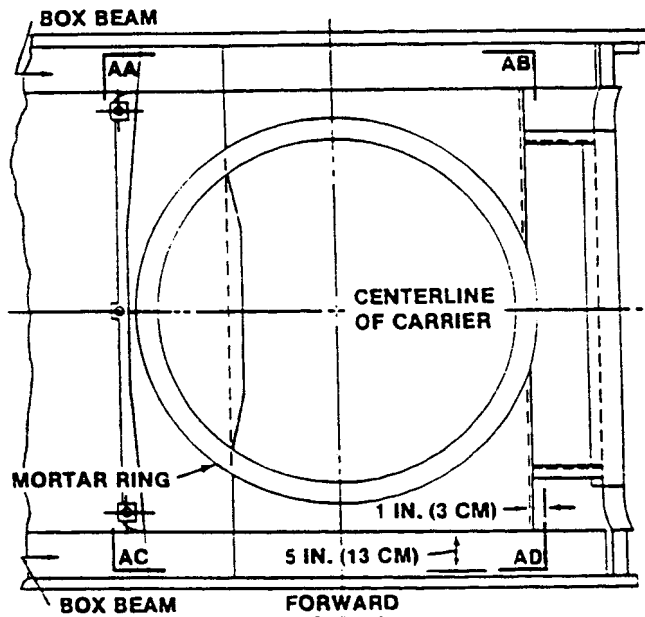
**GENERAL WELDING INSTRUCTIONS**

1. Remove any parts that are in the way or may be damaged.
2. Basic welding repairs are made on 5083 aluminum alloy using the MIG (Gas Metal Arc) welding method.
3. Aluminum welds contract about 6 percent in volume when they become solid. Welding at a slow speed may cause too much heating of the area around the weld. This will cause the metal to expand too much. It will then shrink too much when it cools.
4. Always use clean filler wire. Filler wire polluted by grease, oil, dust, or shop fumes causes porous welds. After welding, cover wire and store in a warm, dry place.
5. Always remove oxides, grease, oil films, paint, and all foreign matter from joint before welding. Wipe edges of joint with clean cloth dipped in solvent and let dry before welding. Sand with disc sander or brush well with clean stainless steel wire brush to remove oxide.
6. Good joint fitup makes welding easier, saves filler wire and gas, and results in higher quality welds. You must tack weld to hold joint members in place if you do not have jigs. Tack welds should be small, neat, and placed to keep parts aligned before and during welding.

7. When welding unequal sections, direct arc against heavier piece to fuse the two edges evenly. Watch weld pool edge rather than arc to make sure weld pool edges fuse right.
8. When performing multi-pass welding, make sure edges of weld pool fuse right. Watch weld pool rather than arc. Any oscillating or weaving motion should be slight, smooth, and slow. Brush material with clean, stainless steel wire brush after each pass. On small weldments, lower amperage slightly after each pass if welding members become too hot.
9. Clean up weld area and touch-up paint all bare metal (see TM 43-0139).
10. Install any parts removed for access.

MIG WELDING METHOD

1. MIG (Gas Metal Arc Welding) uses a dc power source, control panel, and welding gun. The gun feeds a consumable bare electrode at a given rate into a molten pool beneath a blanket of inert gas. When an arc is struck, a molten pool forms at once. Move the welding gun along the joint line at a rate that shapes the right size bead. The covering of inert gas keeps air from polluting the weld zone. No flux is needed.
2. Lead angle and cant angle are important. Place gun at a lead angle of 10° to 15° off vertical. Point gun in direction of weld travel for good gas coverage, cleaning, and preheating of material. Place gun at cant angle of 90° to parent metal so filler wire and arc are directed toward apex of groove. This will give equal fusion to both sides of material, even weld buildup, and equal penetration.

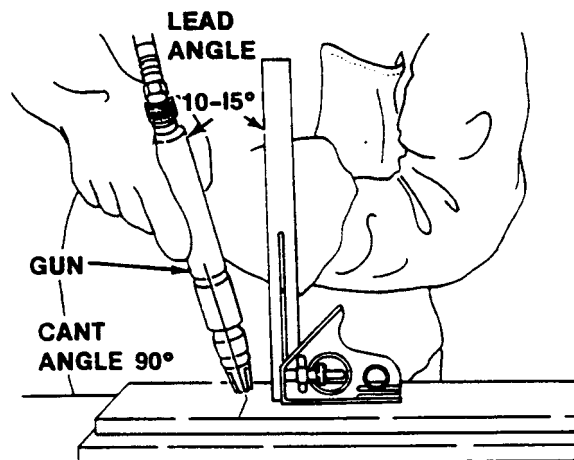

3. Keep nozzle clearance of 1/2 to 5/8 inch (12 to 16 mm) for good gas coverage. Wrong nozzle clearance will cause the following:

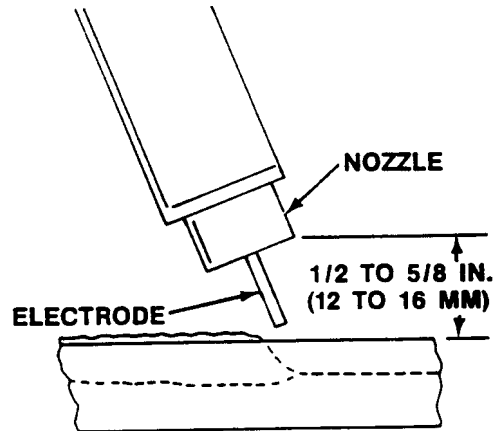

- a. Oxide deposits in the weld bead.
 - b. Force gas bubbles into the weld.
 - c. Prevent cleaning action on the material in front of the weld pool.
4. You will hear a smooth hissing or buzzing sound when the right arc length is struck.
 5. For further welding instructions, see TM 9-237.

FOLLOW-THROUGH STEPS

1. Connect battery ground strap (WP 0337 00), (WP 0338 00), or (WP 0339 00).

END OF TASK

REPLACE DRIVER'S HATCH CUSHIONING PAD

0530 00

THIS WORK PACKAGE COVERS:

Removal (page 0530 00-1).
 Installation (page 0530 00-1).

INITIAL SETUP:

Maintenance Level

Unit

Personnel Required

Unit Mechanic

Tools and Special Tools

General Mechanic's Tool Kit (WP 0926 00, Item 65)

References

See your -10

Materials/Parts

Lockwasher (6)

Equipment Condition

Engine stopped (see your -10)
 Carrier blocked (see your -10)

REMOVAL

1. Remove six screws (1), lockwashers (2), washers (3), and cushioning pad (4) from hatch opening. Discard lockwashers.

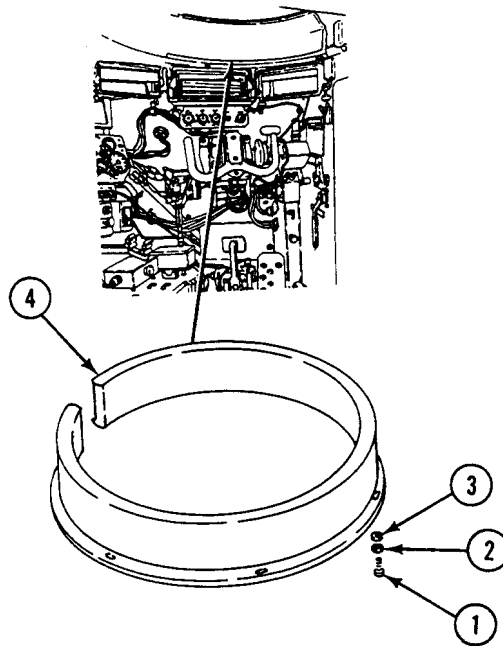

INSTALLATION

1. Place cushioning pad (4) in hatch opening. Secure with six washers (3), new lockwashers (2), and screws (1).

END OF TASK

REPLACE DRIVER’S HATCH COVER AND EXTERIOR LOCK

0531 00 ■

THIS WORK PACKAGE COVERS:

Removal (page 0531 00-1).
 Installation (page 0531 00-3).

INITIAL SETUP:

Maintenance Level

Unit

References

See your -10

Tools and Special Tools

General Mechanic’s Tool Kit (WP 0926 00, Item 65)

Equipment Condition

Engine stopped (see your -10)
 Carrier blocked (see your -10)
 Driver’s hatch interior latch disconnected
 from hatch cover (WP 0534 00)
 Driver’s hatch periscope guard removed (WP 0536 00)
 Driver’s hatch periscope quick release
 assembly removed (see your -10)

Materials/Parts

Grease (WP 0928 00, Item 12)
 Cotter pin
 Locknut (3)
 Seal

Personnel Required

Unit Mechanic

REMOVAL

WARNING

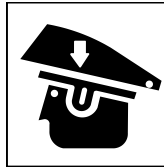

Falling hatch could seriously injure you.

Keep head lower than closed hatch position when opening or closing hatch. Keep hands clear of hatch rim when closing. Make sure latch pin or mechanism is fully engaged when hatch is in any open position.

REPLACE DRIVER'S HATCH COVER AND EXTERIOR LOCK - Continued

0531 00

1. Remove two locknuts (1), screws (2), and retainer (3) from hinge brackets. Discard locknuts.
2. Support cover (4). Remove springs (5), shield (6), two fiber washers (7), and cover from hinge brackets.
3. Remove locknut (8) and screw (9) from cover (4). Discard locknut.
4. Pry up end of seal (10) and remove from cover (4). Discard seal.

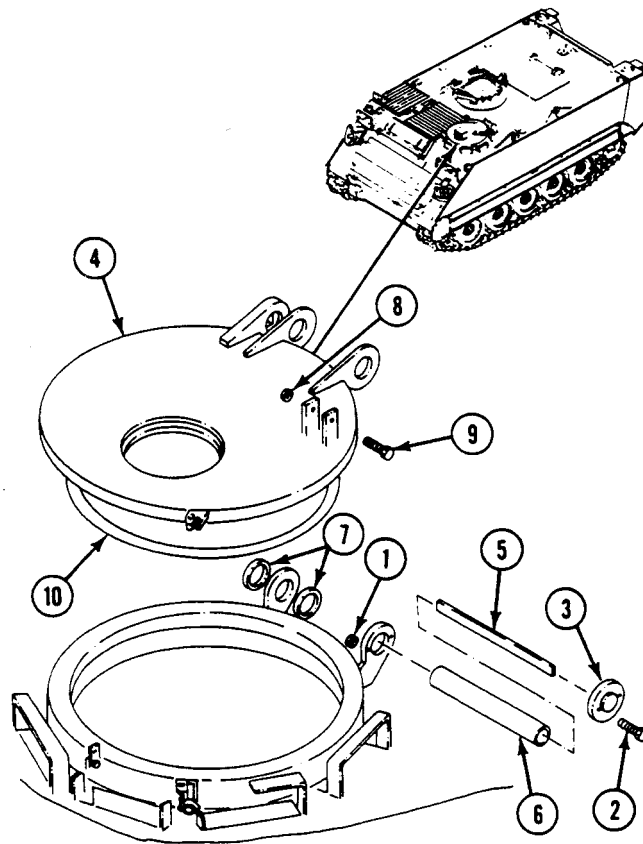

REPLACE DRIVER'S HATCH COVER AND EXTERIOR LOCK - Continued**0531 00**

5. Remove wing nut (1), washer (2), and bushing (3) from bolt (4).
6. Remove cotter pin (5) from headed pin (6). Discard cotter pin.
7. Remove pin (6) and bolt (4) from bracket on hatch.

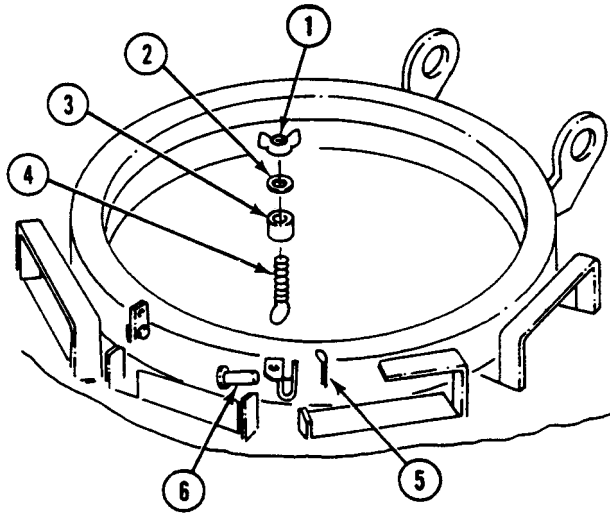
**INSTALLATION**

1. Align bolt (4) with bracket on hatch. Secure with headed pin (6) and new cotter pin (5).
2. Install bushing (3), washer (2), and wing nut (1) on bolt (4).

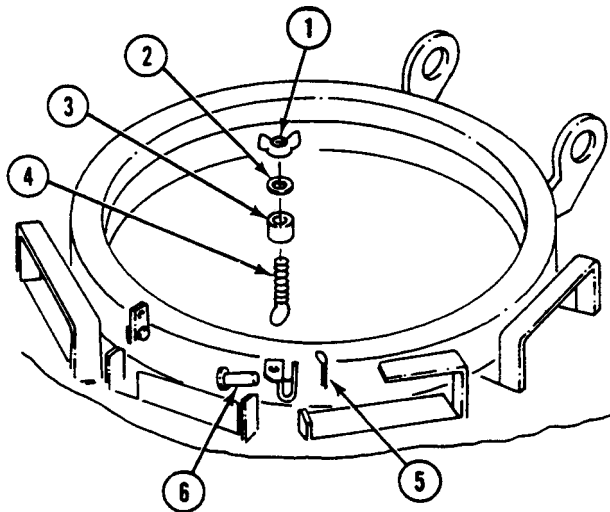

REPLACE DRIVER'S HATCH COVER AND EXTERIOR LOCK - Continued**0531 00**

3. Place new seal (7) over retaining groove in cover (8) and press seal into place. Trim end, if needed.
4. Install screw (9) in cover (8) and secure with new locknut (10).
5. Align cover (8) with hinge brackets and install two fiber washers (11) and shield (12).
6. Apply light coat of grease to each spring (13). Install springs in shield (12).
7. Place cover (8) in vertical position and install retainer (14) on hinge brackets. Secure with two screws (15) and new locknuts (16).

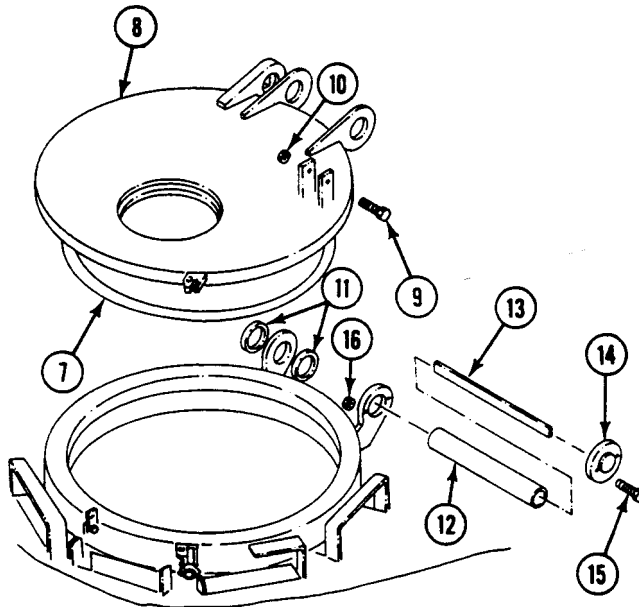
**FOLLOW-THROUGH STEPS**

1. Install driver's hatch periscope quick release assembly (see your -10).
2. Install driver's hatch periscope guard (WP 0536 00).
3. Connect driver's hatch interior latch to cover (WP 0534 00).

END OF TASK

REPLACE DRIVER'S HATCH HOLD-OPEN HOOK AND BUMPER (M113A3, M1059A3, M1064A3, AND M58 ONLY)

0532 00

THIS WORK PACKAGE COVERS:

Removal (page 0532 00-1).
 Installation (page 0532 00-2).

INITIAL SETUP:

Maintenance Level

Unit

References

See your -10

Tools and Special Tools

General Mechanic's Tool Kit WP 0926 00, Item 65

Equipment Condition

Engine stopped (see your -10)

Carrier blocked (see your -10)

Materials/Parts

Locknut
 Locknut (2)

Personnel Required

Unit Mechanic

REMOVAL

1. Open both ends of S-hook (1). Remove S-hook from chain (2) and hull bracket (3).
2. Remove tube (4) from chain (2).
3. Open both ends of S-hook (5). Remove S-hook from chain (2) and safety pin (6). Remove safety pin from hull bracket.
4. Remove two screws (7), four washers (8), two locknuts (9), and block (10) from hull bracket (3). Discard locknuts.

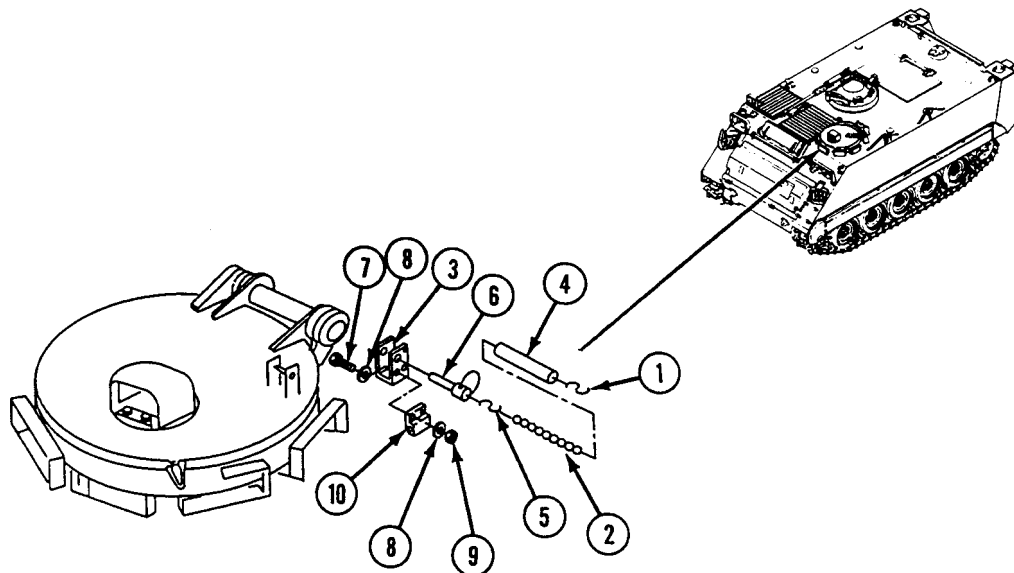

REPLACE DRIVER'S HATCH HOLD-OPEN HOOK AND BUMPER (M113A3, M1059A3, M1064A3, AND M58 ONLY) — Continued

0532 00

5. From inside carrier, remove nut (11) and washer (12). Remove bumper (13) and washer(s) (14) from hull top plate.
6. Remove locknut (15), screw (16), two washers (17), spring (18), spacers (19), and hold-open hook (20) from hull bracket (21). Discard locknut.

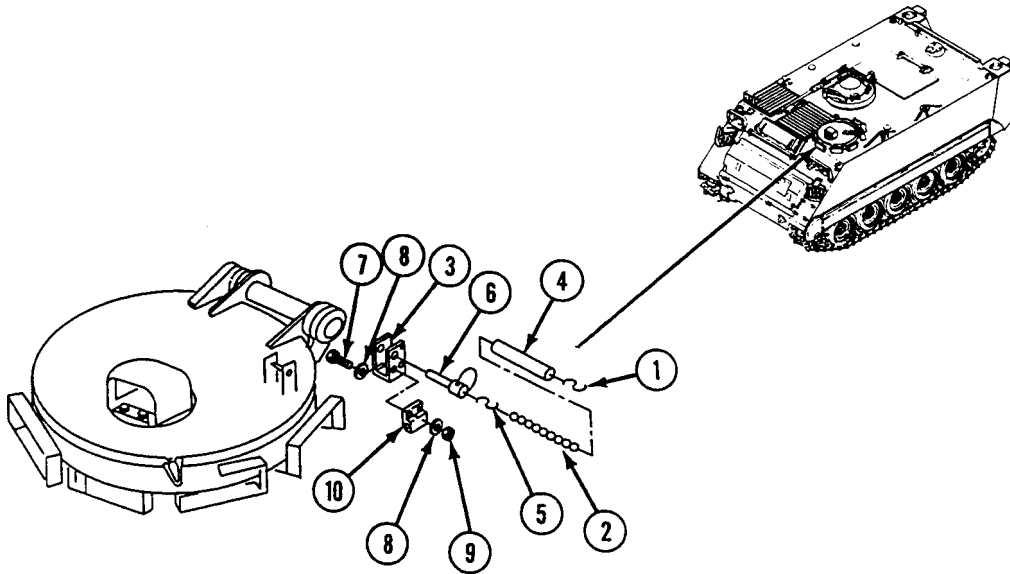
**INSTALLATION**

1. Align hold-open hook (20), two spacers (19), spring (18), and two washers (17) with hull bracket (21). Secure with screw (16) and new locknut (15).

REPLACE DRIVER'S HATCH HOLD-OPEN HOOK AND BUMPER (M113A3, M1059A3, M1064A3, AND M58 ONLY) — Continued

0532 00

NOTE

Install washer(s), as needed, to compress bumper 1/4 inch (6 mm) when hold-open hook is engaged.

2. Install washer(s) (14) and bumper (13) in hull top plate. From inside carrier, secure with washer (12) and nut (11).

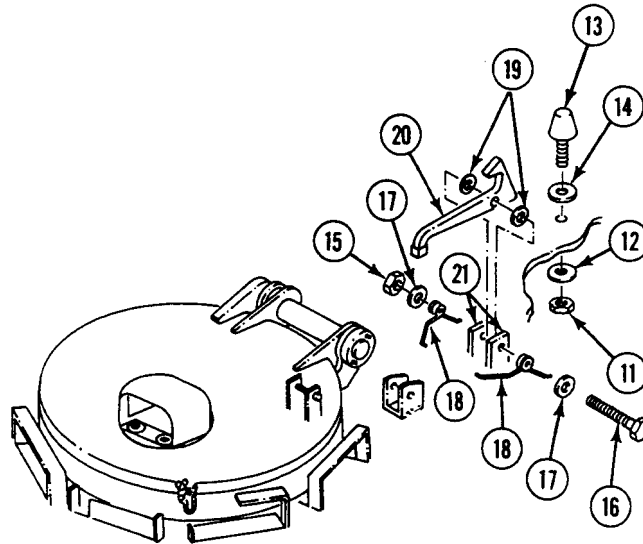

3. Place block (1) on hull bracket (2). Secure with two screws (3), four washers (4), and two new locknuts (5).
4. Install S-hook (6) in safety pin (7) and chain (8). Squeeze both ends of S-hook to secure.
5. Install tube (9) on chain (8).
6. Install S-hook (10) in chain (8) and on hull bracket (2). Squeeze both ends of S-hook to secure.

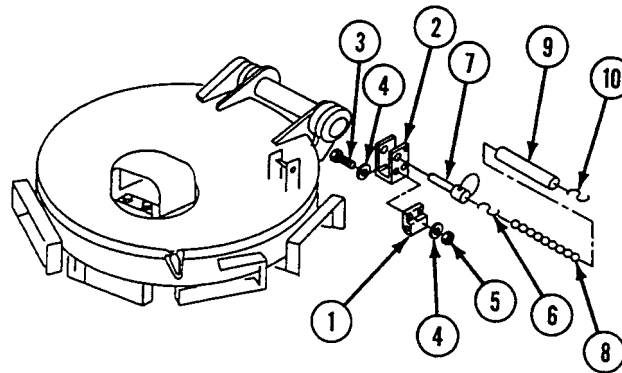

FOLLOW-THROUGH STEPS

1. Open and close driver's hatch cover and engage hold-open hook to check that hook and bumper are installed correctly.

END OF TASK

REPLACE DRIVER'S HATCH HOLD-OPEN HOOK AND BUMPER (M577A3 AND M1068A3 ONLY)

0533 00

THIS WORK PACKAGE COVERS:

- Removal (page 0533 00-1).
- Cleaning (page 0533 00-2).
- Repair (page 0533 00-2).
- Installation (page 0533 00-3).

INITIAL SETUP:

Maintenance Level

Unit

References

See your -10

Tools and Special Tools

General Mechanic's Tool Kit (WP 0926 00, Item 65)

Equipment Condition

Engine stopped (see your -10)
Carrier blocked (see your -10)

Materials/Parts

Locknut
Locknut (2)

Personnel Required

Unit Mechanic

REMOVAL

1. Open both ends of hook (1). Remove from chain (2) and hull bracket.
2. Remove tube (3) from chain (2).
3. Open both ends of hook (4). Remove from chain (2) and quick-release pin (5).
4. Remove nut (6), washer(s) (7), bumper (8), and washer(s) (9) from bulkhead bracket.
5. Remove locknut (10), screw (11), two washers (12), spring (13), two spacers (14), and hook (15) from hull bracket. Discard locknut.

REPLACE DRIVER'S HATCH HOLD-OPEN HOOK AND BUMPER (M577A3 AND M1068A3 ONLY) — Continued

0533 00

6. Remove two screws (16), locknuts (17), four washers (18), and block (19) from hull bracket. Discard locknuts.

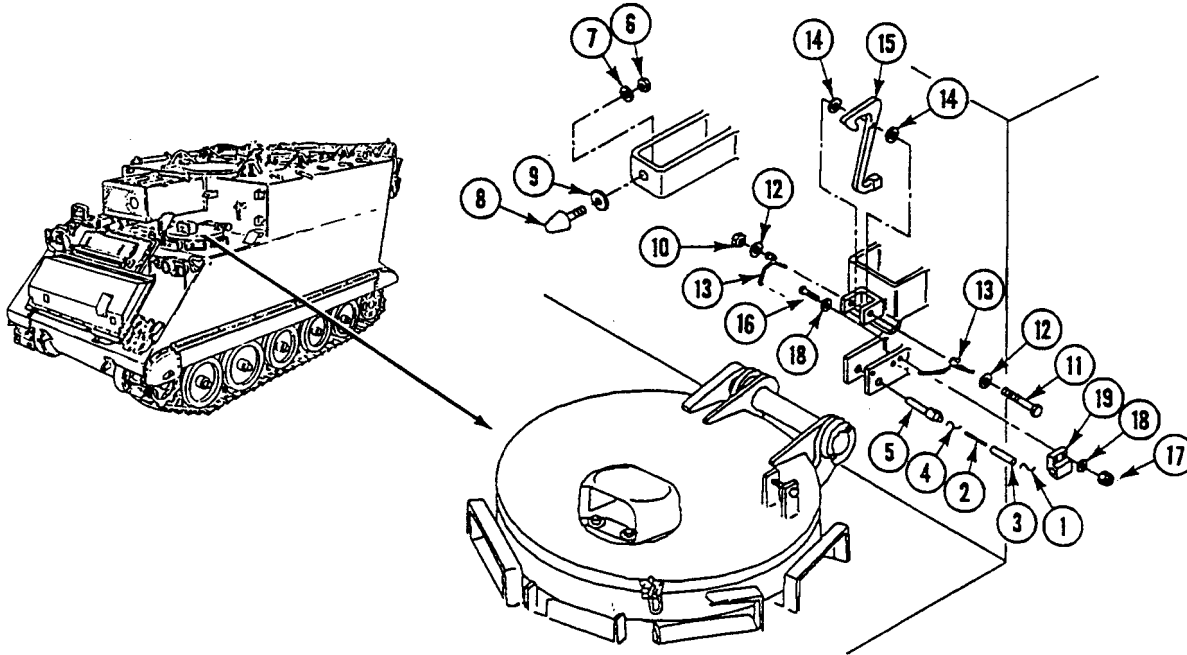
**CLEANING**

1. Check spring.
2. Check bumper.

REPAIR OR REPLACEMENT

1. Replace broken or weak spring.
2. Replace bumper that is cut, hard, or has stripped threads.

REPLACE DRIVER'S HATCH HOLD-OPEN HOOK AND BUMPER (M577A3 AND M1068A3 ONLY) — Continued

0533 00

INSTALLATION

1. Install block (1) on hull bracket and secure with two screws (2), four washers (3), and two new locknuts (4).
2. Install hook (5), two spacers (6), and spring (7) in hull bracket. Secure with screw (8), two washers (9) and new locknut (10).

NOTE

Install washers (11) and (13) as needed to compress bumper 1/4 inch (6 mm) when hook is engaged.

3. Install washer(s) (11) and bumper (12) on hull bracket. Secure with washer(s) (13) and nut (14).
4. Install hook (15) on quick-release pin (16) and chain (17). Squeeze both ends of hook to secure.
5. Install tube (18) on chain (17).
6. Install hook (19) on chain (17) and hull bracket. Squeeze both ends of hook to secure.

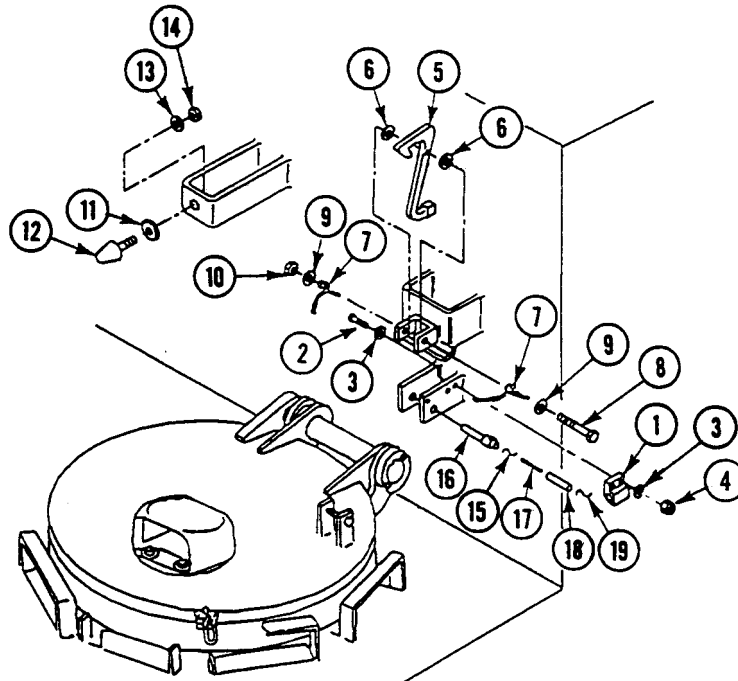

FOLLOW-THROUGH STEPS

1. Open and close driver's hatch cover and engage hook to check that hook and bumper are properly installed. Open and close driver's hatch cover and engage hook to check that hook and bumper are properly installed.

END OF TASK

REPLACE DRIVER'S HATCH INTERIOR LOCK AND LATCH**0534 00****THIS WORK PACKAGE COVERS:**

Removal (page 0534 00-1).
 Installation (page 0534 00-2).
 Adjustment (page 0534 00-3).

INITIAL SETUP:Maintenance Level

Unit

Personnel Required

Unit Mechanic

Tools and Special Tools

General Mechanic's Tool Kit (WP 0926 00, Item 65)

References

See your -10

Materials/Parts

Cotter pin (2)

Equipment Condition

Engine stopped (see your -10)
 Carrier blocked (see your -10)

REMOVAL

1. Remove cotter pin (1) from headed pin (2). Discard cotter pin.
2. Remove pin (2), two washers (3), spring (4), and eyebolt (5) from driver's hatch bracket.

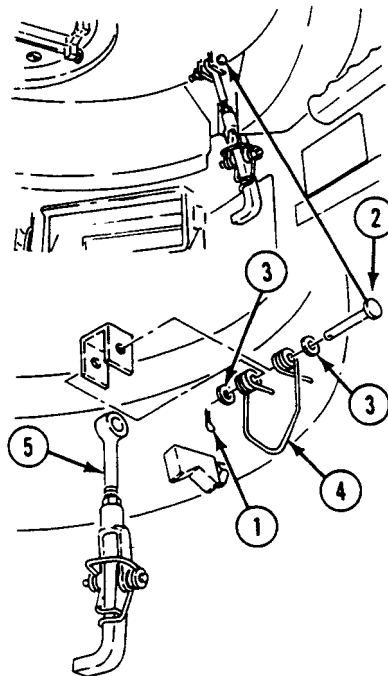

3. Remove cotter pin (6) from headed pin (7). Discard cotter pin.
4. Remove pin (7), two washers (8), spring (9), and latch (10) from clevis (11).
5. Loosen nut (12). Remove eyebolt (5) from clevis (11).

- Loosen nut (13). Remove lug (14) from bulkhead. Remove nut from lug.

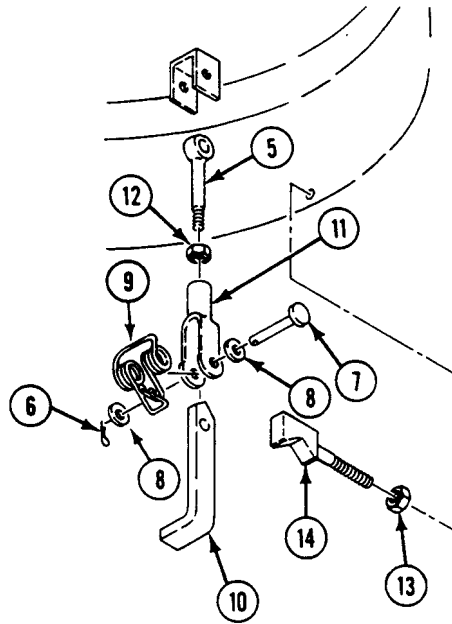

INSTALLATION

- Install nut (1) on lug (2). Install lug in bulkhead. Do not tighten nut.
- Install nut (3) and eyebolt (4) in clevis (5). Do not tighten nut.
- Align latch (6), spring (7), and two washers (8) with clevis (5). Secure with headed pin (9) and new cotter pin (10).

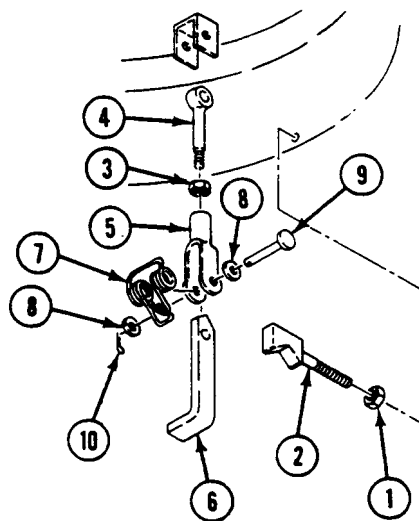

- Align eyebolt (4), spring (11), and two washers (12) with driver's hatch bracket. Secure with headed pin (13) and new cotter pin (14).

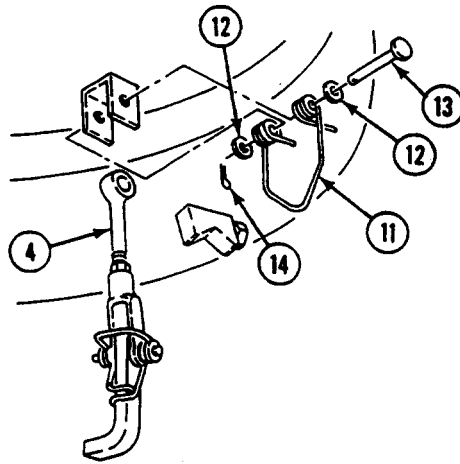

ADJUSTMENT

- Perform Step 2 and Step 3 to adjust lock and latch.
- Turn clevis (5) on eyebolt (4) until hatch closes tightly on hull in the latched position with maximum clearance of $3/32$ inch (2 mm). Tighten nut (3).
- Turn lug (2) until latch (6) is in line with clevis (5) or $1/4$ inch (6 mm) maximum above clevis in the latched position. Tighten nut (1) on lug.

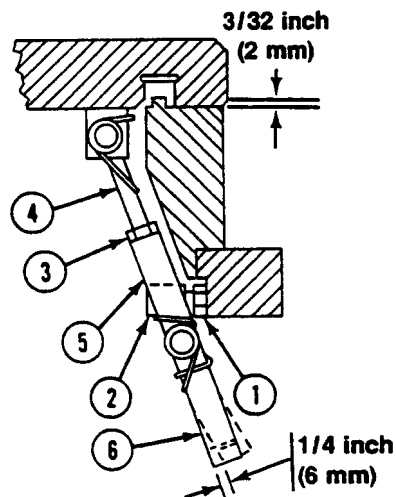

FOLLOW-THROUGH STEPS

1. Close hatch. Check that hatch lock and latch are installed right.

END OF TASK

REPLACE DRIVER’S HATCH VISION BLOCK LOCKS AND SEALS

0535 00

THIS WORK PACKAGE COVERS:

- Removal (page 0535 00-1).
 - Cleaning, Inspection, and Repair (page 0535 00-3).
 - Installation (page 0535 00-3).
-

INITIAL SETUP:

Maintenance Level

Unit

Personnel Required

Unit Mechanic

Tools and Special Tools

- General Mechanic’s Tool Kit (WP 0926 00, Item 65)
- Socket Wrench Set (WP 0926 00, Item 73)
- Torque Wrench (WP 0926 00, Item 81)
- Torque Wrench (WP 0926 00, Item 84)

References

See your -10

Materials/Parts

- Adhesive (WP 0928 00, Item 5)
- Cleaning compound solvent (WP 0928 00, Item 18)
- Rubber seal
- Spring pin

Equipment Condition

- Engine stopped (see your -10)
 - Carrier blocked (see your -10)
 - Ramp lowered (see your -10)
 - Vision block removed (see your -10)
-

REMOVAL

NOTE

There are six vision block locks and four seals on the driver’s hatch. Task is for one lock and seal.

Driver’s center vision block is held in place by two thumbscrews mounted on the warning light panel.

Steps 1 - 4 apply to all carriers except M1064A3.

1. Remove thumbscrew (1) from arm (2).
2. Remove spring pin (3) from arm (2). Discard pin.
3. Remove arm (2) and washer (4) from hull bracket.

4. Scrape seal (5) from vision block opening.

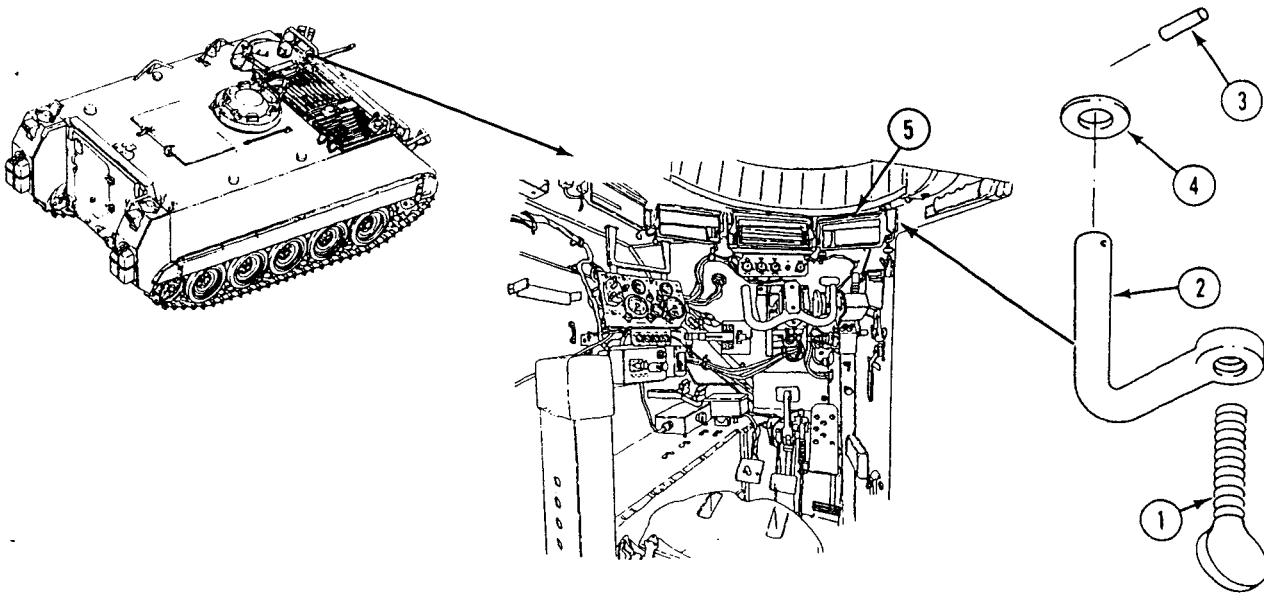

NOTE

Steps 5 - 8 apply to M1064A3 only.

5. Remove thumbscrew (1) and spring (2) from periscope clamp (3).
6. Remove bolt (4), washer (5), and periscope clamp (3) from post (6).
7. Remove post (6) and washer (7) from driver's hatch.

8. Scrape seal (8) from vision block opening.

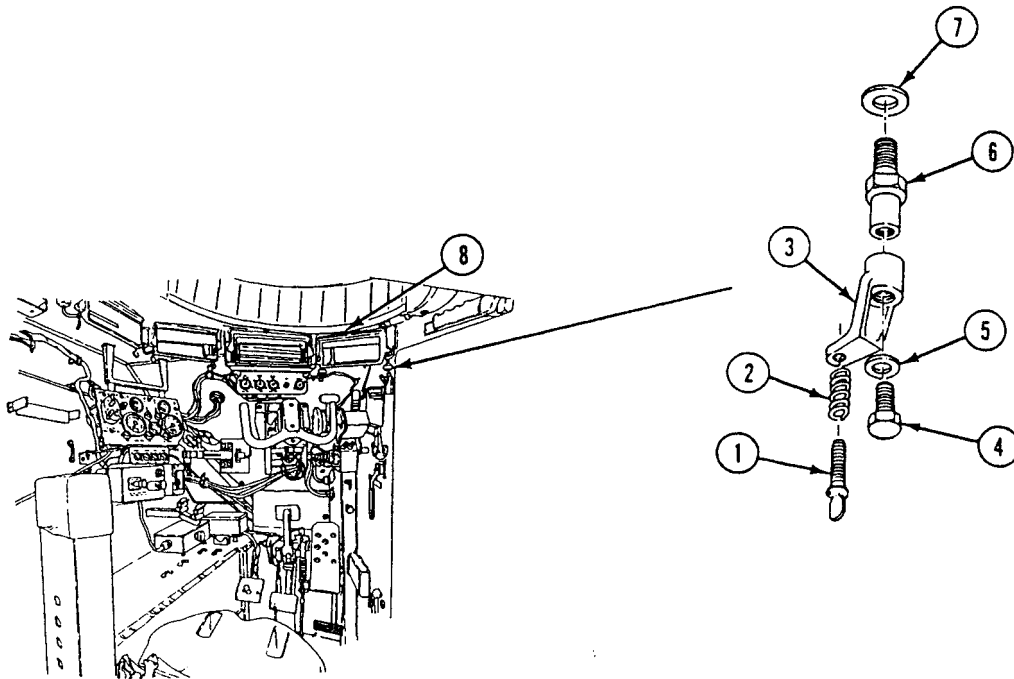

CLEANING

CLEANING, INSPECTION, AND REPAIR

1. Clean seal mating surface on hull with cleaning compound.

INSTALLATION

NOTE

Surface on seal marked **BOND THIS SIDE** should be glued to hull.

1. Apply adhesive to mating surface around vision block opening. Allow to become tacky. Install new seal (8) on hatch.

NOTE

Steps 2 - 4 apply to M1064A3 only.

2. Install washer (7) and post (6) in driver's hatch. TIGHTEN POST TO 54-59 LB-FT (73-80 N·m) TORQUE.
3. Install periscope clamp (3) on post (6). Secure with washer (5) and bolt (4). TIGHTEN BOLT TO 144-168 LB-IN (16-19 N·m) TORQUE.

4. Install spring (2) and thumbscrew (1) on periscope clamp (3). Deform first thread of thumbscrew to prevent easy removal.

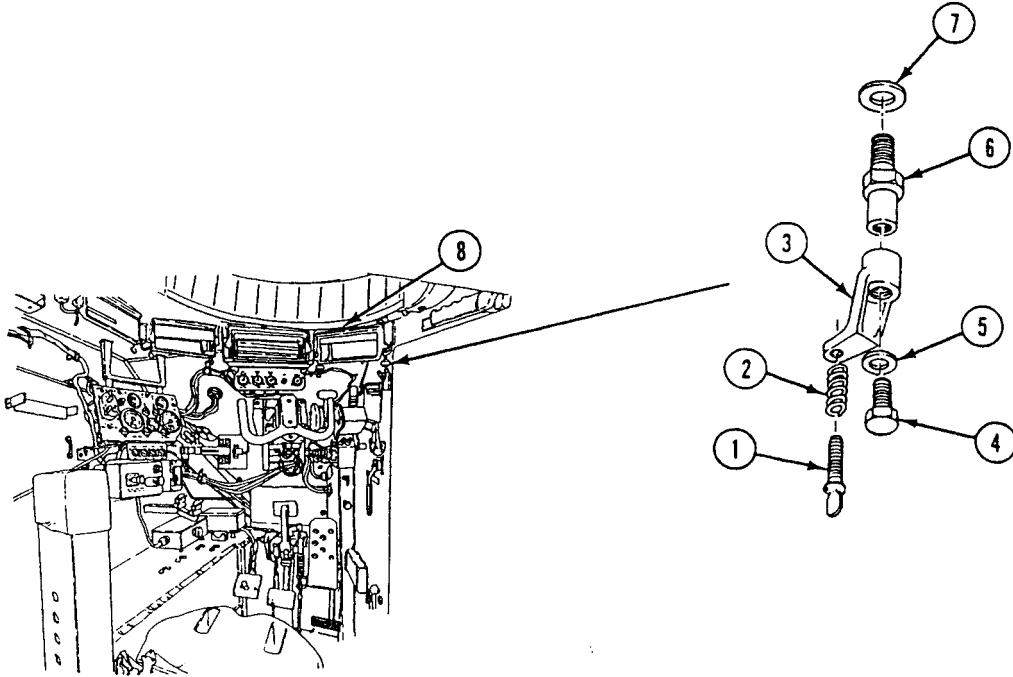

NOTE

Step 5 and Step 6 apply to all carriers except M1064A3.

5. Install arm (1) and washer (2) in hull bracket (3). Secure with new spring pin (4).
6. Install thumbscrew (5) in arm (1). Deform first thread of thumbscrew to prevent easy removal.

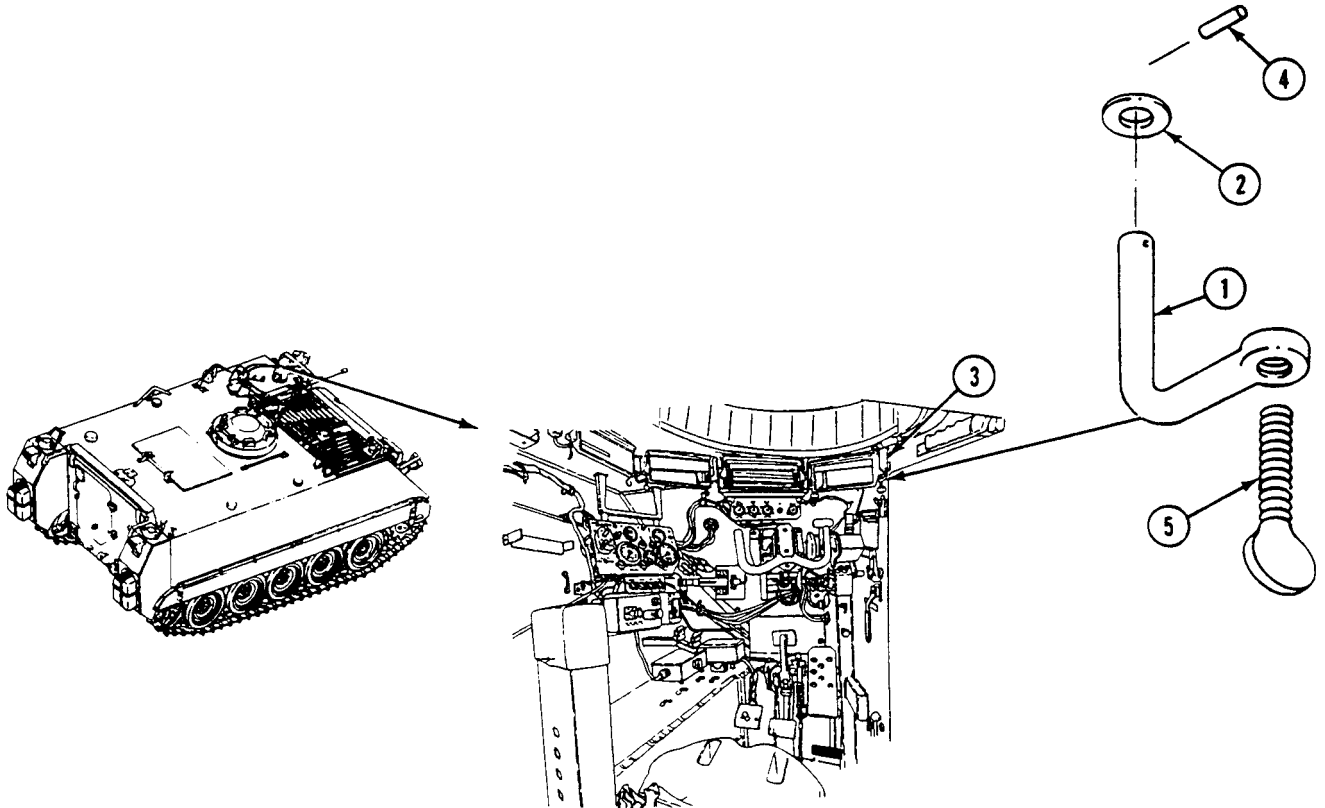
**FOLLOW-THROUGH STEPS**

1. Install vision blocks (see your -10).
2. Start engine (see your -10).
3. Raise and lock ramp (see your -10).
4. Stop engine (see your -10).

END OF TASK

**REPLACE DRIVER'S HATCH AN/VVS-2 DRIVER'S NIGHT VISION GUARD
(ALL EXCEPT M58)**

0536 00

THIS WORK PACKAGE COVERS:

Removal (page 0536 00-1).
Installation (page 0536 00-1).

INITIAL SETUP:

Maintenance Level

Unit

Personnel Required

Unit Mechanic

Tools and Special Tools

General Mechanic's Tool Kit (WP 0926 00, Item 65)

References

See your -10

Materials/Parts

Adhesive (WP 0928 00, Item 3)
Lockwasher (4)
Seal (2)

Equipment Condition

Engine stopped (see your -10)
Carrier blocked (see your -10)

REMOVAL

1. Remove four screws (1), lockwashers (2), washers (3), and guard (4) from driver's night vision mounting hatch (5). Discard lockwashers.
2. Remove one seal (6) from top of driver's night vision mounting hatch (5). Discard seal.

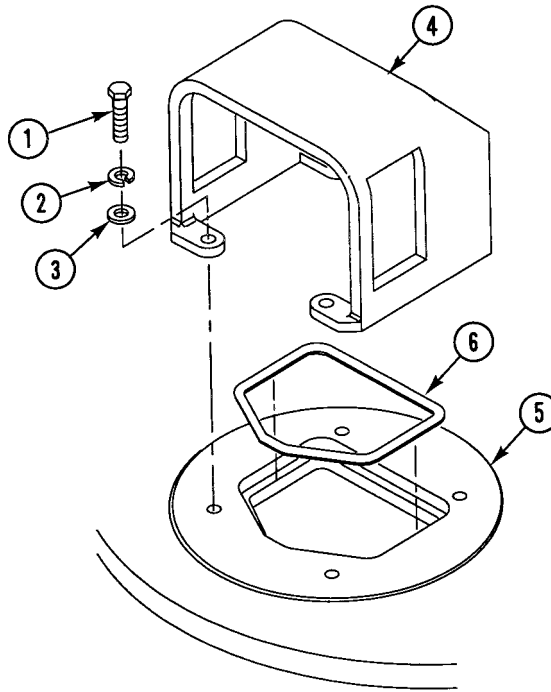

INSTALLATION

1. Apply adhesive to mating surface on mounting hatch (5). Install new seal (6).

REPLACE DRIVER'S HATCH AN/VVS-2 DRIVER'S NIGHT VISION GUARD (ALL EXCEPT M58) — Continued

0536 00

2. Place guard (4) on mounting hatch (5). Secure with four washers (3), new lockwashers (2), and screws (1).

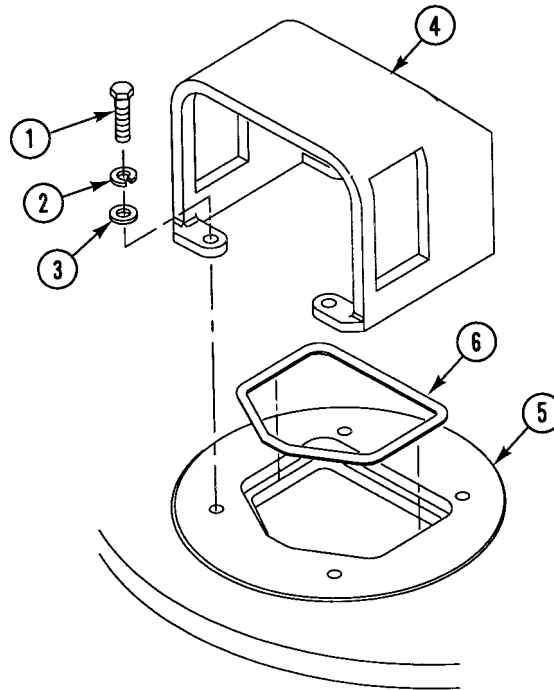
**END OF TASK**

REPLACE DRIVER'S HATCH NIGHT VISION GUARD (M58 ONLY)

0536 01

THIS WORK PACKAGE COVERS:

Removal (page 0536 01-1).
 Installation (page 0536 01-2).

INITIAL SETUP:

Maintenance Level

Unit

Personnel Required

Unit Mechanic

Tools and Special Tools

General Mechanic's Tool Kit (WP 0926 00, Item 65)

References

See your -10

Materials/Parts

Adhesive (WP 0928 00, Item 3)
 Lockwasher (4)
 Seal

Equipment Condition

Engine stopped (see your -10)
 Carrier blocked (see your -10)

REMOVAL

1. Remove four screws (4), lockwashers (3), washers (6), nut (7), and guard (1) from driver's night vision hatch mounting bracket (2). Discard lockwashers.
2. Remove one seal (5) from top of driver's night vision hatch mounting bracket (2). Discard seal.

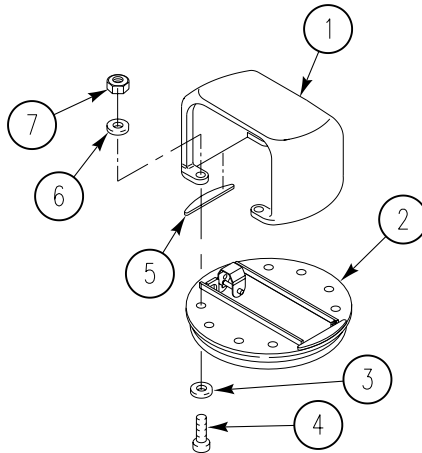

INSTALLATION

1. Apply adhesive to mating surface on mounting bracket (2). Install new seal (5).
2. Place guard (1) on mounting bracket (2). Secure with four washers (6), new lockwashers (3), screws (4), and nuts (7).

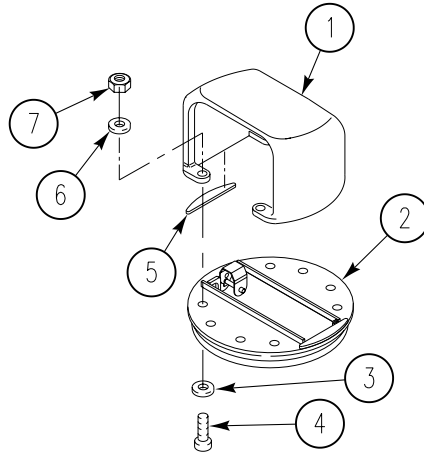
**END OF TASK**

REPLACE AN/VVS-2 DRIVER'S NIGHT VISION MOUNT (ALL EXCEPT M58)

0537 00

THIS WORK PACKAGE COVERS:

Removal (page 0537 00-1).
 Installation (page 0537 00-2).

INITIAL SETUP:

Maintenance Level

Unit

Personnel Required

Unit Mechanic

Tools and Special Tools

General Mechanic's Tool Kit (WP 0926 00, Item 65)

References

See your -10

Materials/Parts

Adhesive (WP 0928 00, Item 3)
 Adhesive (RTV) (WP 0928 00, Item 6)
 Lockwasher (4)
 Lockwasher (3)
 Seal
 Seal
 Spring

Equipment Condition

Engine stopped (see your -10)
 Carrier blocked (see your -10)
 Driver's hatch opened (see your -10)
 Driver's night vision removed (see your -10)
 Driver's night vision guard removed (WP 0536 00)

REMOVAL

1. Loosen two viewer handles (1) on mount (2) and slide back rear cleat (3). Remove plug (4) from mount.
2. Remove three screws (5), lockwashers (16) and mount (2) from driver's hatch (6), and mounting hatch (17). Discard lockwashers
3. Remove seal (7) from mounting hatch (17). Discard seal.
4. Remove two viewer handles (1) and rear cleat (3) from mount (2).
5. Remove two screws (8) and handle (9) from rear cleat (3).
6. Remove four screws (10), lockwashers (11), and two forward cleats (12). Discard lockwashers.
7. Remove seal (13) from mount (2). Discard seal.

8. Remove spring (14) and key (15) from mount (2). Discard spring.

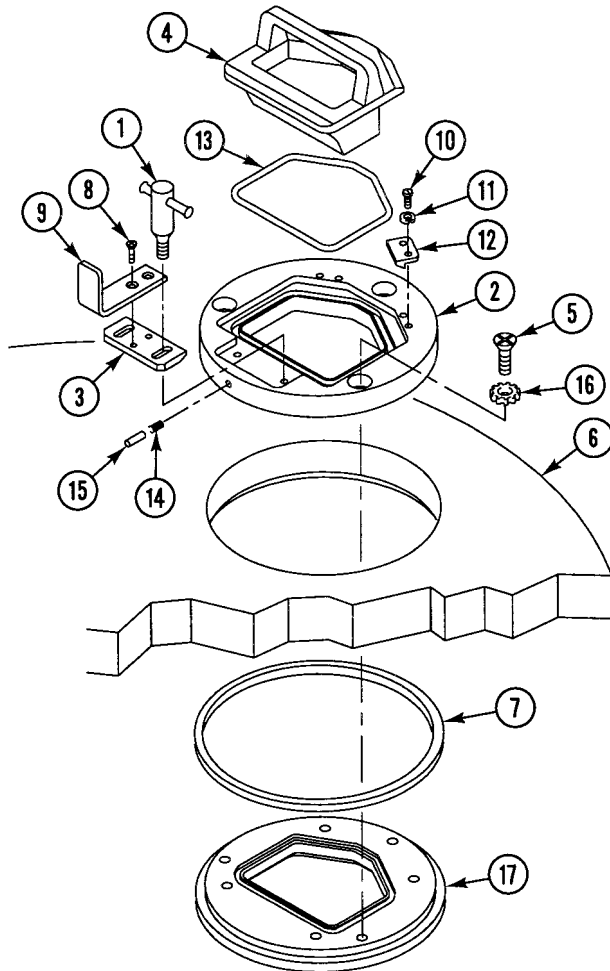

INSTALLATION

1. Install key (1) and new spring (14) on mount (2).
2. Apply adhesive to mating surface on mount and install new seal (15) in mount (2).
3. Install two forward cleats (3), four new lockwashers (4), and screws (5) on mount (2).
4. Apply adhesive to two screw threads (7) and install handle (6) and two screws (7) on rear cleat (8).
5. Install rear cleat (8) and two viewer handles (9) on mount (2).
6. Apply adhesive to mating surfaces of mounting hatch (16) and mount (2).
7. Install new seal (11) on mounting hatch (16).
8. Install mount (2), three new lockwashers (17), and screws (12) on driver's hatch (10) and mounting hatch (16).

9. Tilt plug (13), slide into mount (2), and tighten two viewer handles (9).

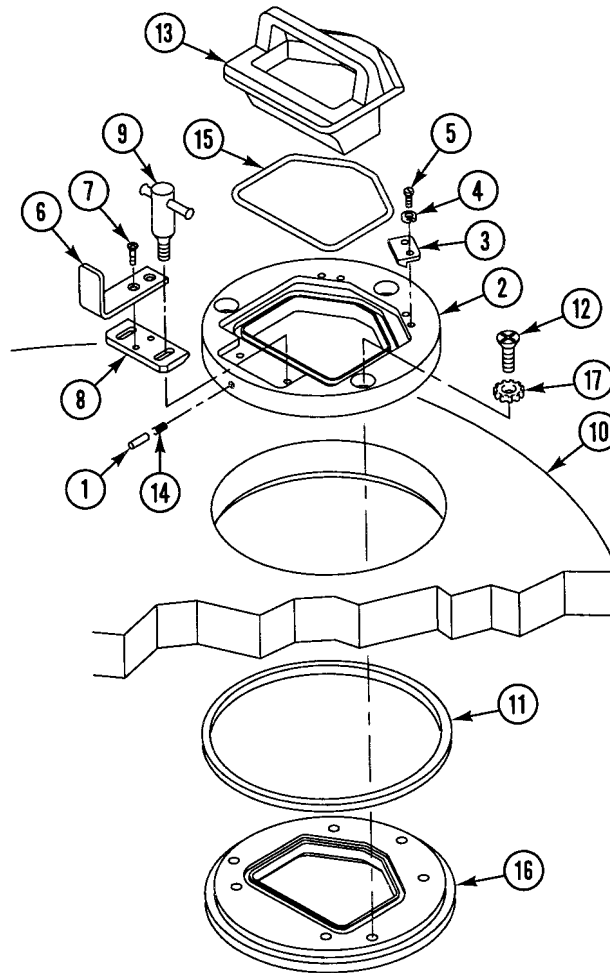

FOLLOW THROUGH STEPS

1. Install driver's night vision guard (WP 0536 00).
2. Install driver's night vision (see your -10).
3. Close driver's hatch (see your -10).

END OF TASK

REPLACE DRIVER'S HATCH NIGHT VISION MOUNT (M58 ONLY)

0537 01

THIS WORK PACKAGE COVERS:

Removal (page 0537 01-1).
 Installation (page 0537 01-2).

INITIAL SETUP:

Maintenance Level

Unit

Personnel Required

Unit Mechanic

Tools and Special Tools

General Mechanic's Tool Kit (WP 0926 00, Item 65)

References

See your -10

Materials/Parts

Adhesive (WP 0928 00, Item 3)
 Lockwasher (4)
 Seal

Equipment Condition

Engine stopped (see your -10)
 Carrier blocked (see your -10)

REMOVAL

1. Retract trunnions (12) using eyebolts (11) and remove plug (13) from mounting plate (5), (19).
2. Remove four screws (17), lockwashers (18), washers (1), nuts (2), and guard (3) from mounting plate (5), (19). Discard lockwashers.
3. Remove seal (4) from top of mounting plate (5), (19). Discard seal.
4. Remove four screws (14), lockwashers (15), azimuth plate assembly (16), and mounting plate (5), (19) from driver's hatch (6).
5. Remove two screws (10), lock washers (9), washers (8) and azimuth lock (20) from driver's hatch (6).
6. Remove two screws (10), lock washers (9), washers (8), and azimuth stop (7) from driver's hatch (6).

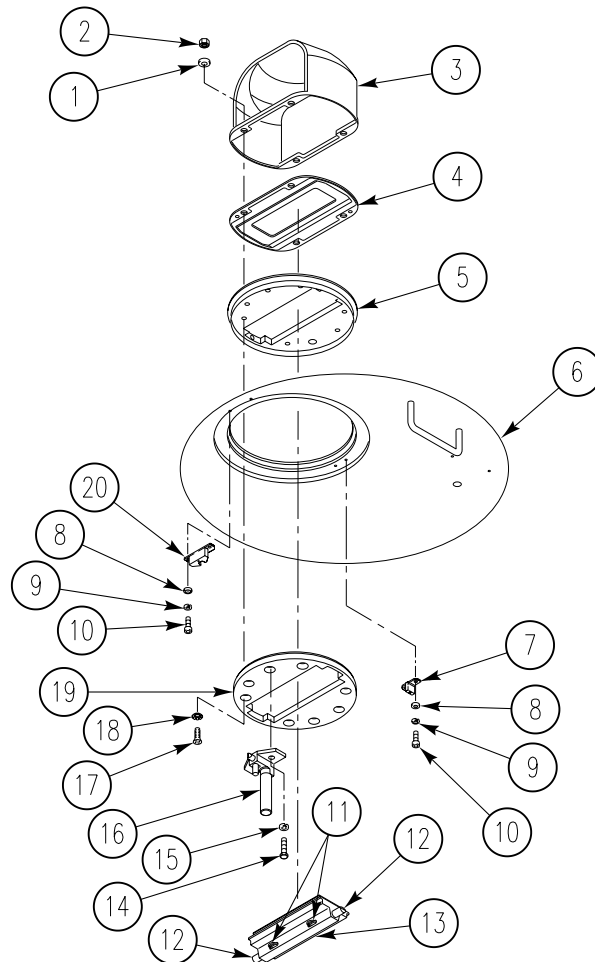

INSTALLATION

1. Install four screws (14), lockwashers (15), azimuth plate assembly (16), and mounting plate (5), (19) on driver's hatch (6).
2. Install plug (13) in mounting plate (5), (19) by retracting trunnions (12) using eye bolts (11).
3. Install two screws (10), lockwashers (9), washers (8), and azimuth lock (20) on driver's hatch (6).
4. Install two screws (10), lockwashers (9), washers (8), and azimuth stop (7) on driver's hatch (6).
5. Apply adhesive to mating surface of mounting plate (5). Install new seal (4) on mounting plate.
6. Place guard (3) on mounting plate (5), (19) and secure with four screws (17), lockwashers (18), washers (1), and nuts (2).

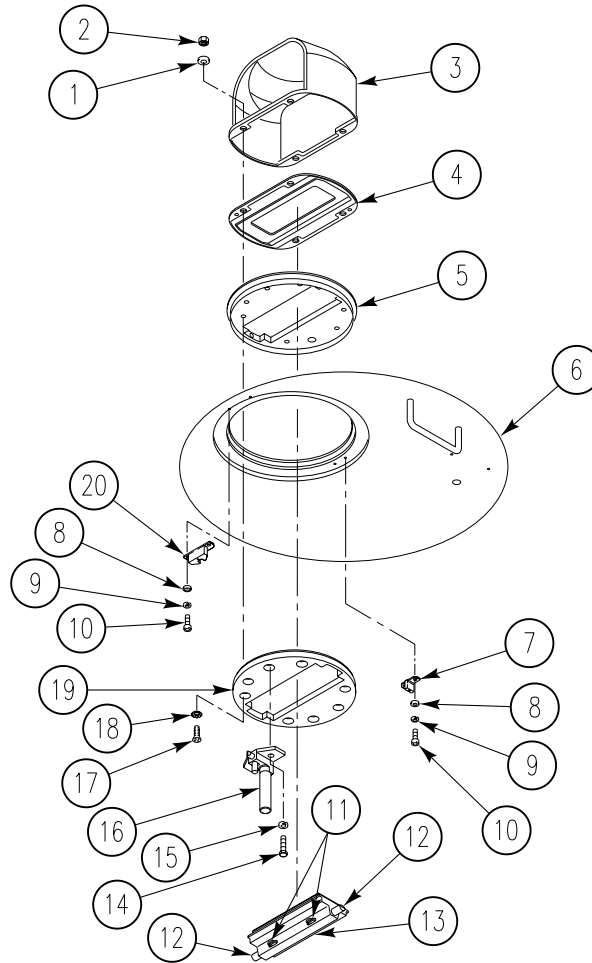

END OF TASK

REPLACE FLOOR PLATES (M113A3 AND M577A3 ONLY)

0539 00

THIS WORK PACKAGE COVERS:

Removal (page 0539 00-1).
 Installation (page 0539 00-2).

INITIAL SETUP:

Maintenance Level

Unit

References

See your -10
 TM 9-2350-277-24P

Tools and Special Tools

General Mechanic's Tool Kit (WP 0926 00, Item 65)

Equipment Condition

Engine stopped (see your -10)
 Carrier blocked (see your -10)
 Ramp lowered (see your -10)
 Personnel heater floor duct removed, if installed
 (WP 0706 00)

Materials/Parts

Adhesive (WP 0928 00, Item 4)
 Rubber strips (if removed)

Personnel Required

Unit Mechanic

REMOVAL

NOTE

Floor plates have some differences. Refer to TM 9-2350-277-24P for part numbers.

1. Remove 16 screws (1) and lined washers (2) from carrier hull.
2. Remove two front floor plates (3) and rear floor plate (4) from hull crossmembers.
3. If needed, remove rubber strips (5) from crossmembers by scraping.

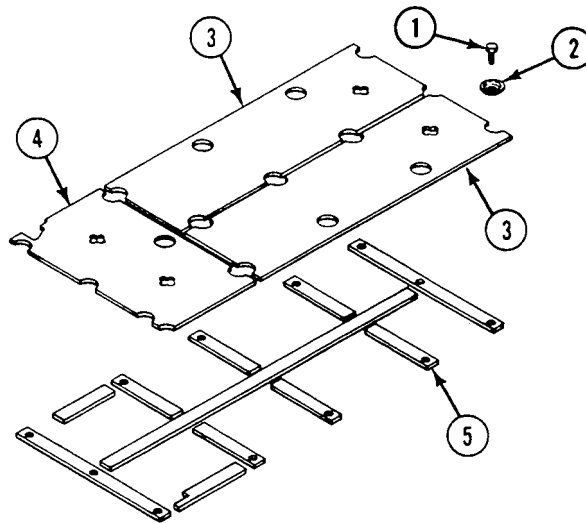

INSTALLATION

1. If rubber strips (5) removed, apply thin coat of adhesive to roughened side of rubber surface. Allow to dry 20-30 minutes. Apply thin coat of adhesive to metal surface of hull crossmembers. Allow to dry 30-120 seconds. Install rubber strips on crossmembers and press surfaces together firmly.
2. Place rear floor plate (4) and two front floor plates (3) on crossmembers. Secure to hull with 16 lined washers (2) and screws (1).

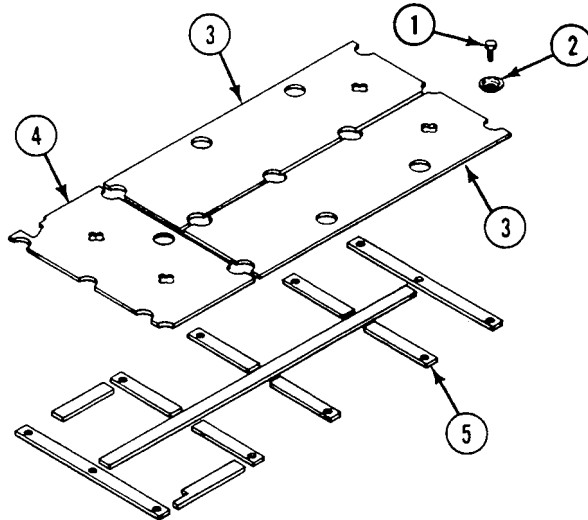
**FOLLOW-THROUGH STEPS**

1. Install personnel heater floor duct, if removed (WP 0706 00).
2. Start engine (see your -10).
3. Raise and lock ramp (see your -10).
4. Stop engine (see your -10).

END OF TASK

REPLACE FLOOR PLATES (M1059A3 ONLY)

0542 00

THIS WORK PACKAGE COVERS:

Removal (page 0542 00-1).
 Installation (page 0542 00-2).

INITIAL SETUP:

Maintenance Level

Unit

References

See your -10

Tools and Special Tools

General Mechanic's Tool Kit (WP 0926 00, Item 65)

Equipment Condition

Engine stopped (see your -10)
 Carrier blocked (see your -10)
 Personnel floor heater duct removed (WP 0706 00)
 Seats folded in stowed position (see your -10)
 Ramp lowered (see your -10)

Materials/Parts

Adhesive (WP 0928 00, Item 4)

Personnel Required

Unit Mechanic

REMOVAL

1. Remove 12 screws (1) and lined washers (2) securing floor plates to hull crossmembers.
2. Remove two screws (3) and washers (4) securing floor plates to hull crossmembers.
3. Remove two rear floor plates (5) and (6) from hull crossmembers.
4. Remove two front floor plates (7) and (8) from hull crossmembers.
5. If necessary, remove two non-metallic seals (9) from hull crossmembers by scraping.
6. If necessary, remove two rubber strips (10) from hull crossmembers by scraping.
7. If necessary, remove eight pads (11) from hull crossmembers by scraping.

8. If necessary, remove two pads (12), four pads (13), and two pads (14)(15) from hull crossmembers by scraping.

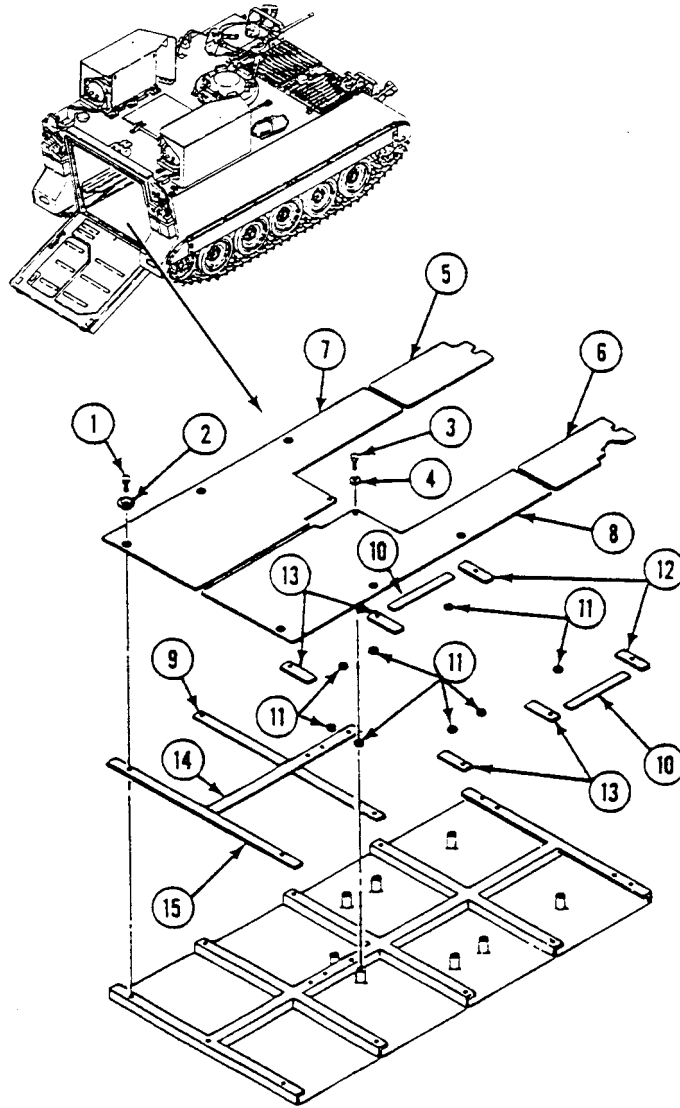

INSTALLATION

1. If pads (1) through (5), rubber strips (6), or seals (7) were removed, apply light coat of adhesive to all crossmember mating surfaces. Allow surfaces to become sticky. Install pads, rubber strips, and seals on crossmembers and press surfaces firmly together.
2. Place two front floor plates (8) and (9) on hull crossmembers.
3. Place two rear floor plates (10) and (11) on hull crossmembers.
4. Install two washers (12) and screws (13) on front floor plates (8) and (9).

5. Install 12 lined washers (14) and screws (15) on front floor plates (8) and (9), and rear floor plates (10) and (11).

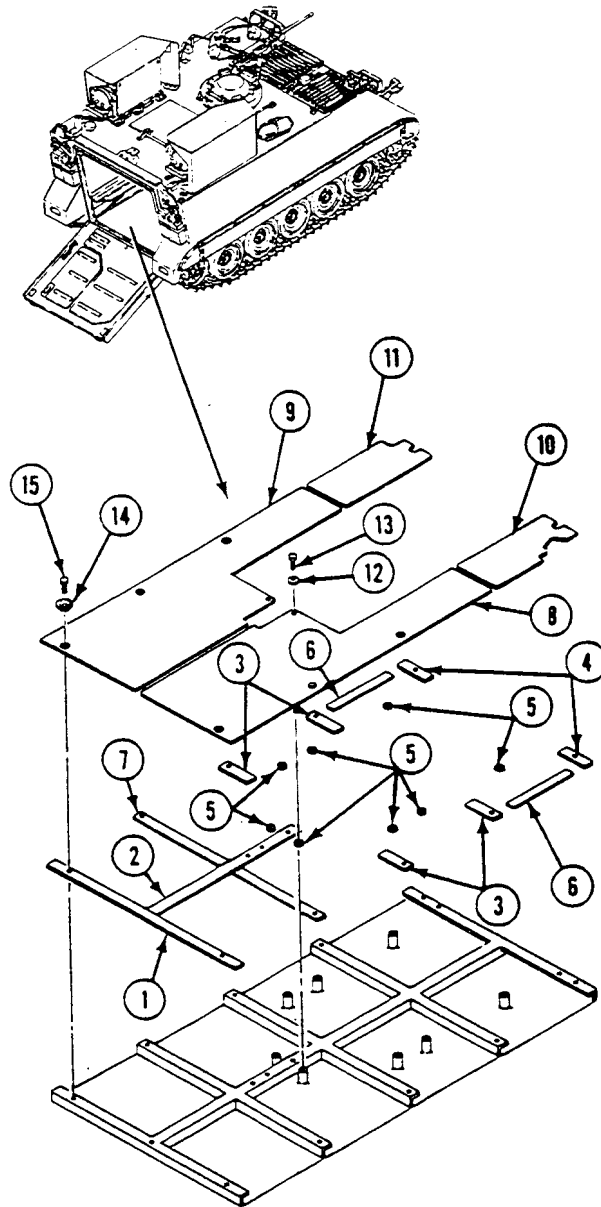

FOLLOW-THROUGH STEPS

1. Install personnel floor heater duct (WP 0706 00).
2. Unstow seats (see your -10).
3. Raise and lock ramp (see your -10).
4. Stop engine (see your -10).

END OF TASK

REPLACE FLOOR PLATES (M1064A3 ONLY)

0543 00

THIS WORK PACKAGE COVERS:

Removal (page 0543 00-1).
 Installation (page 0543 00-2).

INITIAL SETUP:

Maintenance Level
 Unit

Personnel Required
 Unit Mechanic

Tools and Special Tools
 General Mechanic's Tool Kit (WP 0926 00, Item 65)

References

See your -10

Materials/Parts

- Adhesive
- Cushioning pad (2)
- Cushioning pad
- Cushioning pad
- Cushioning pad (3)
- Cushioning pad
- Locknut (2)
- Locknut
- Non-metallic seal (2)
- Non-metallic seal

Equipment Condition

- Engine stopped (see your -10)
- Carrier blocked (see your -10)
- Ramp lowered (see your -10)
- Personnel heater floor duct removed, if installed. (WP 0706 00)

REMOVAL

1. Remove screw (1) and washer (2) from guard (3).
2. Remove screw (4), washer (5), locknut (6), and guard (3) from hull. Discard locknut.

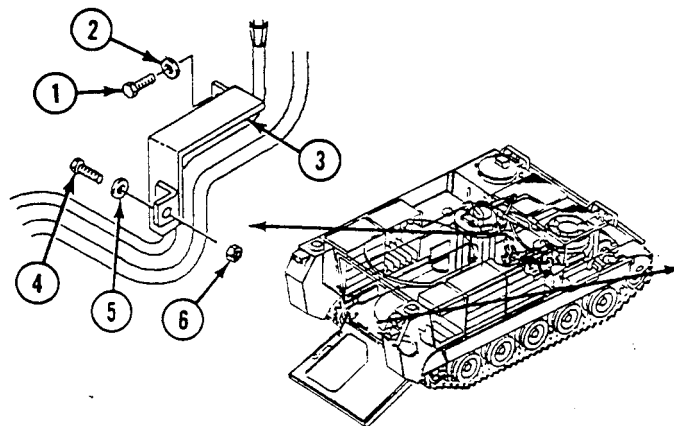

3. Remove eight eyebolts (7), one screw (8), and nine lined washers (9) from right front floor plate (10) and left front floor plate (11).
4. Remove two screws (12), lined washers (13), and rear floor plate (14) from carrier.
5. Remove two locknuts (15), washers (16), screws (17), and guard (18) from rear floor plate (14). Discard locknuts.
6. If necessary, remove two pads (19), three pads (20), and pad (21) from front crossmembers by scraping.

7. If necessary, remove two pads (22) and (23) and three seals (24) and (25) from crossmembers by scraping.

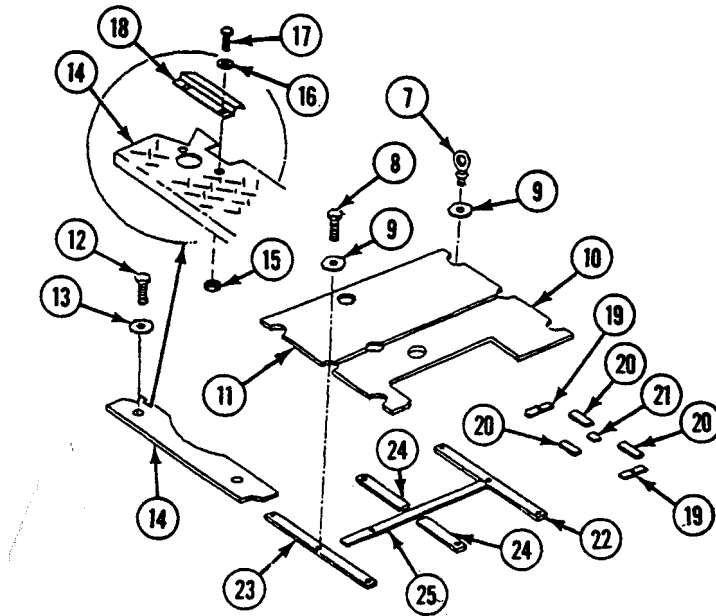

INSTALLATION

1. If pads (1) thru (5) or seals (6) and (7) were removed, apply light coat of adhesive to crossmember mating surfaces. Allow surfaces to become tacky. Install pads and seals on crossmembers and press surfaces together firmly.
2. Install guard (8), two screws (9), washers (10), and new locknuts (11) on rear floor plate (12).
3. Place rear floor plate (12) in carrier. Secure with two lined washers (13) and screws (14).

REPLACE FLOOR PLATES (M1064A3 ONLY) — Continued

0543 00

4. Place left front floor plate (15) and right front floor plate (16) in carrier. Secure with nine lined washers (17), one screw (18), and eight eyebolts (19).

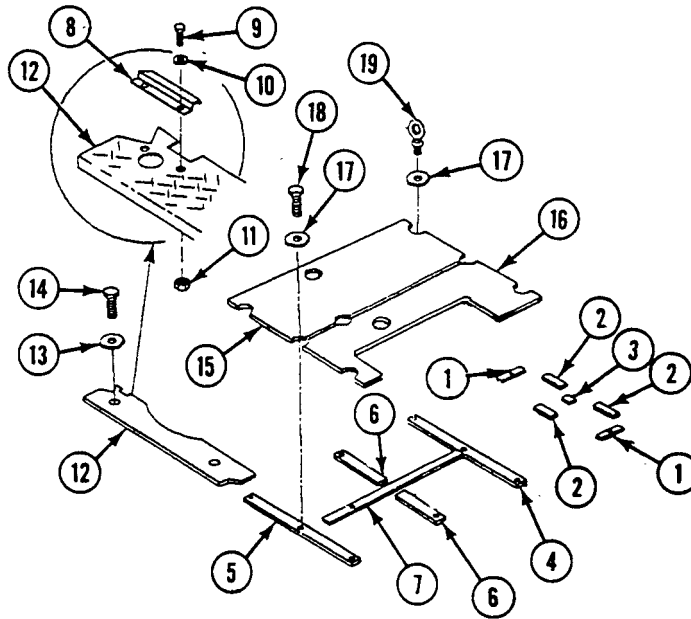

5. Install guard (20) on hull with screw (21), washer (22), and new locknut (23).
6. Install screw (24) and washer (25) on guard (20).

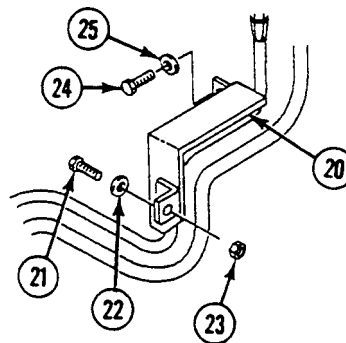

FOLLOW-THROUGH STEPS

1. Install personnel heater floor duct, if removed. (WP 0706 00).
2. Start engine (see your -10).
3. Raise and lock ramp (see your -10).
4. Stop engine (see your -10).

END OF TASK

REPLACE FLOOR PLATES (M1068A3 ONLY)

0544 00

THIS WORK PACKAGE COVERS:

Removal (page 0544 00-1).
 Installation (page 0544 00-2).

INITIAL SETUP:

Maintenance Level

Unit

References

See your -10
 TM 9-2350-277-24P

Tools and Special Tools

General Mechanic's Tool Kit (WP 0926 00, Item 65)

Equipment Condition

Engine stopped/shutdown (see your -10)
 Carrier blocked (see your -10)
 Ramp lowered (see your -10)
 Personnel heater floor duct removed (WP 0706 00)
 Power supply storage box removed (WP 0824 00)

Materials/Parts

Adhesive (WP 0928 00, Item 4)

Personnel Required

Unit Mechanic

REMOVAL

NOTE

Floor plates have some differences. Refer to TM 9-2350-277-24P for part numbers.

1. Remove 13 screws (1) and lined washers (2) from carrier hull.
2. Remove two front floor plates (3), (4) and rear floor plate (5) from hull crossmembers.

3. If necessary, remove two pads (6)(7), rubber strips (8), six seals (9), and seal (10) from crossmembers by scraping.

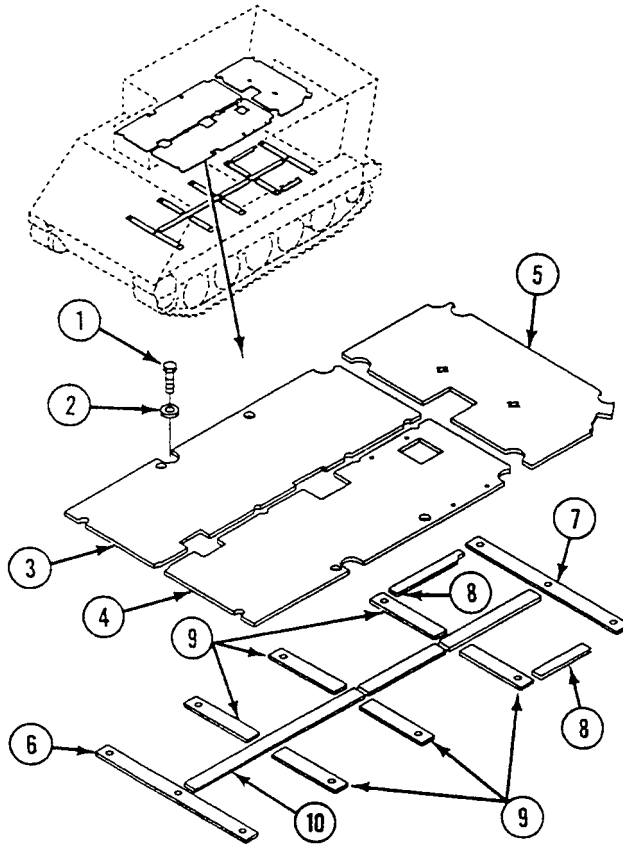

INSTALLATION

1. If pads, strips, or seals (6) through (10) were removed, apply thin coat of adhesive to roughened side of surface. Allow to dry 20-40 minutes. Apply thin coat of adhesive to metal surface of hull crossmembers. Allow to dry 30-120 seconds. Install pads, strips, and seals on crossmembers and press surfaces together firmly.
2. Place rear floor plate (5) and 2 front floor plates (4)(3) on hull crossmembers. Secure to hull with 13 lined washers (2) and screws (1).

FOLLOW-THROUGH STEPS

1. Install personnel heater floor duct (WP 0706 00).
2. Install power supply storage box (WP 0824 00).
3. Raise and lock ramp (see your -10).
4. Stop engine (see your -10).

END OF TASK

REPLACE FLOOR PLATES (M58 ONLY)

0545 00

THIS WORK PACKAGE COVERS:

Removal (page 0545 00-1).
 Installation (page 0545 00-2).

INITIAL SETUP:

Maintenance Level

Unit

References

TM 3-1040-285-20

Tools and Special Tools

General Mechanic's Tool Kit (WP 0926 00, Item 65)

Equipment Condition

Engine stopped (see your -10)
 Carrier blocked (see your -10)
 Ramp lowered (see your -10)
 Personnel floor heater duct removed (WP 0706 00)
 Smoke generator system removed
 (TM 3-1040-285-20)

Materials/Parts

Adhesive (WP 0928 00, Item 5)

Personnel Required

Unit Mechanic

References

See your -10

REMOVAL

1. Remove six screws (1) and washers (2) securing plates (3)(4)(5) to supports.
2. Remove eight screws (6) and lined washers (7) from carrier hull.
3. Remove two front plates (3)(4) and two rear plates (5)(8) from hull crossmembers.

4. If necessary, remove four pads (9) through (11) from crossmembers by scraping.

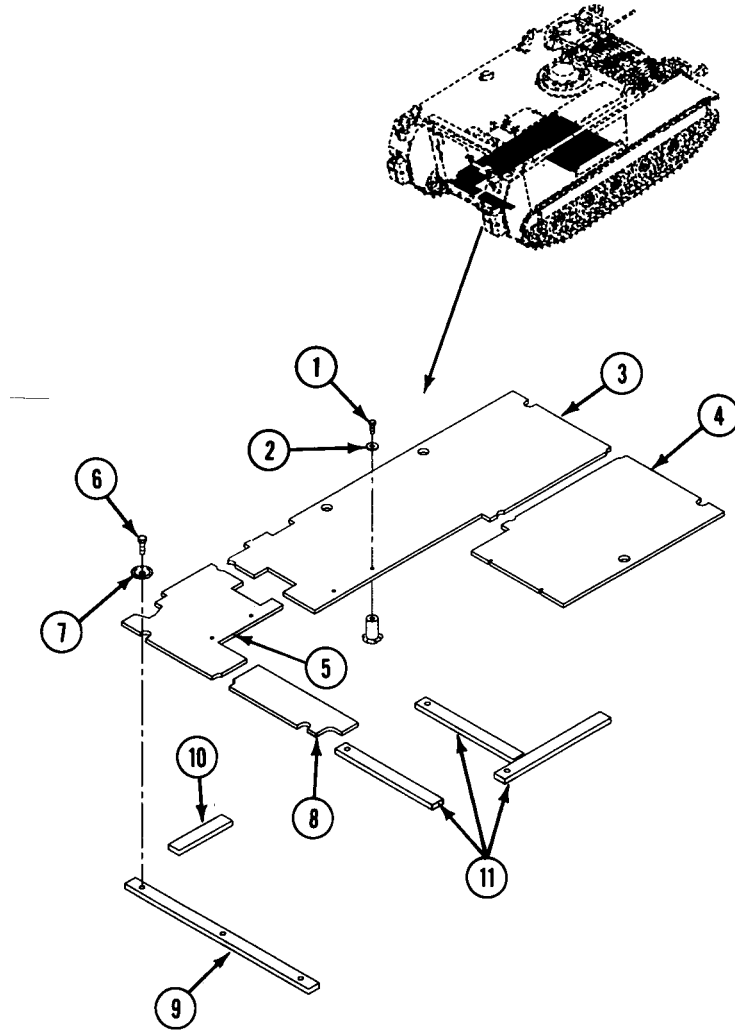

INSTALLATION

1. If pads (1) through (3) were removed, apply thin coat of adhesive to roughed side of surface. Allow to dry 20-40 minutes. Apply thin coat of adhesive to metal surface of hull crossmembers. Allow to dry 30-120 seconds. Install pads on crossmembers and press firmly.
2. Install two front plates (4)(5) and two rear plates (6)(7) to hull crossmembers.
3. Install eight lined washers (8) and screws (9) to carrier hull.

REPLACE FLOOR PLATES (M58 ONLY) — Continued

0545 00

4. Install six washers (10) and screws (11) to three plates (4)(5)(6) securing them to supports.

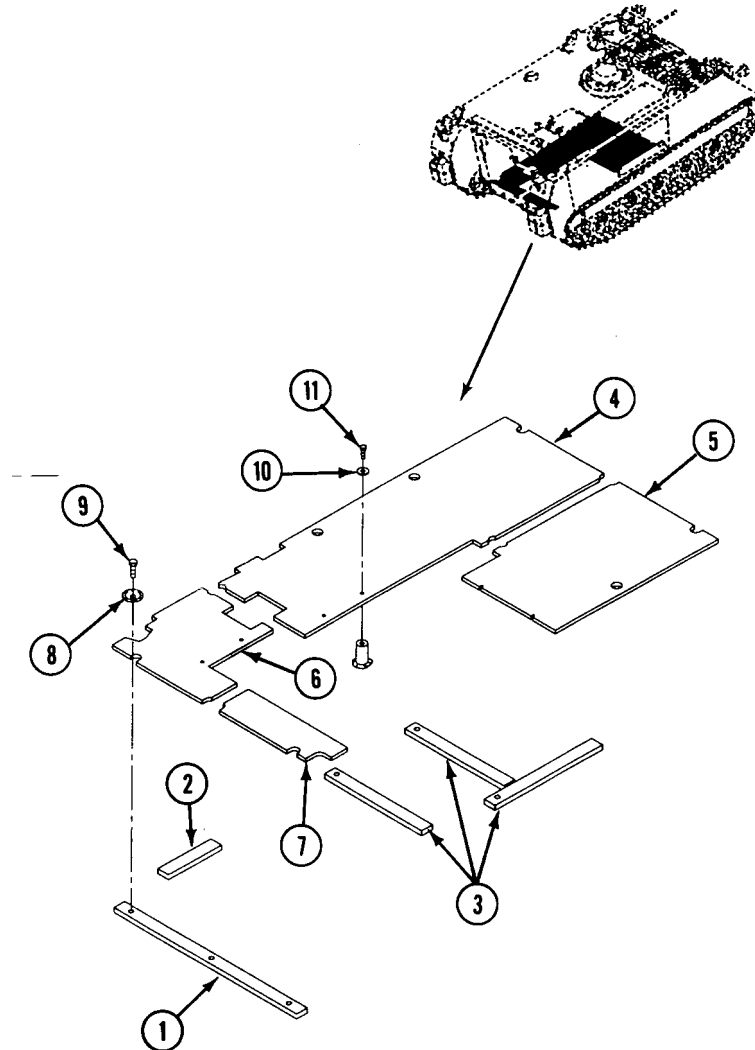
**FOLLOW-THROUGH STEPS**

1. Install personnel floor heater duct (WP 0706 00).
2. Raise and lock ramp (see your -10).
3. Stop engine (see your -10).
4. Install smoke generator system (TM 3-1040-285-20).

END OF TASK

REPLACE PERSONNEL SEATS, CUSHIONS, AND BELTS (M113A3 ONLY)

0546 00

THIS WORK PACKAGE COVERS:

- Removal (page 0546 00-1).
- Installation (page 0546 00-2).

INITIAL SETUP:

Maintenance Level

Unit

Personnel Required

Unit Mechanic

Tools and Special Tools

General Mechanic's Tool Kit (WP 0926 00, Item 65)

References

See your -10

Materials/Parts

- Cotter pin (8)
- Gasket (4)
- Locknut (4)

Equipment Condition

- Engine stopped (see your -10)
- Carrier blocked (see your -10)

REMOVAL

NOTE

There are four seats in the M113A3. Replace all seats the same way.

1. Remove two straps (1) and cushion (2) from seat (3).
2. Remove four cotter pins (4), gaskets (5), two straight pins (6), and seat (3) from sponson bracket (7). Discard cotter pins and gaskets.
3. Remove four cotter pins (9), two straight pins (10), and two legs (11) from seat (3). Discard cotter pins.

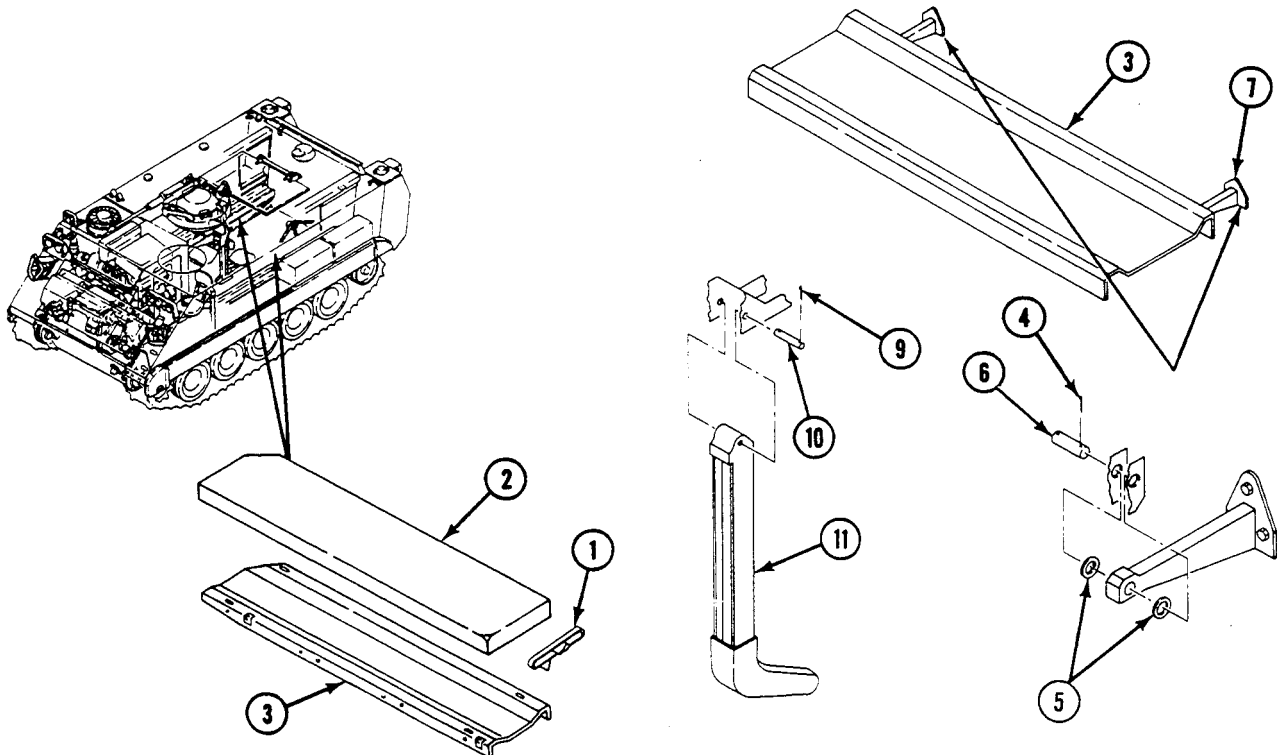

4. Remove two locknuts (1), washers (2), screws (3), and seat-belt (4) for each position on seat (5). Discard locknuts.
5. Remove three screws (6), washers (7), and bracket (8), from seat (5).

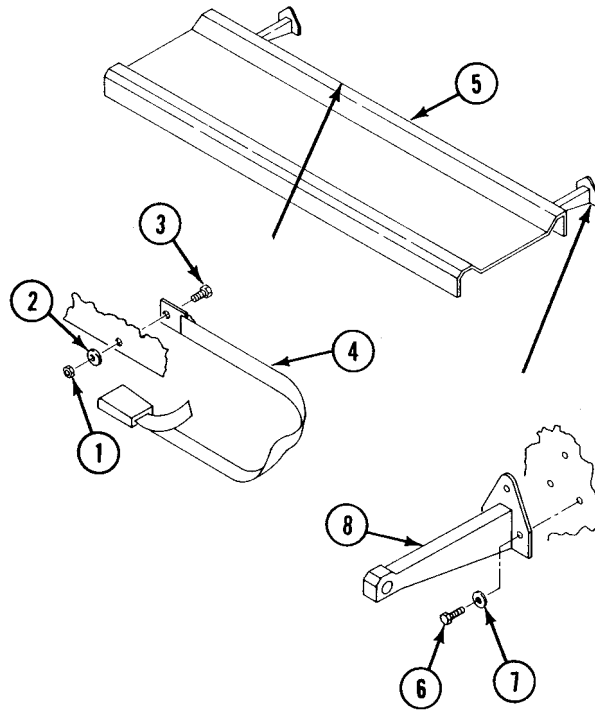

INSTALLATION

1. Secure bracket (8) against sponson (9) with three screws (6), and washers (7).

2. Install two new locknuts (1), washers (2), screws (3), and seat-belt (4) for each position on seat (5).

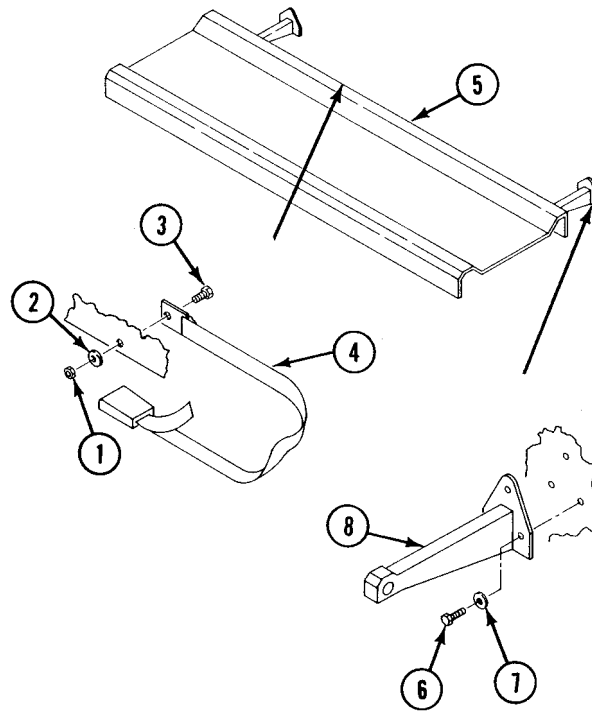

3. Align two legs (10) with seat (5). Secure with two straight pins (11) and four new cotter pins (12).
4. Align seat (5) with sponson bracket (13). Secure with two straight pins (14), four new gaskets (15) and cotter pins (16).
5. Place cushion (17) on seat (5). Secure with two straps (18).

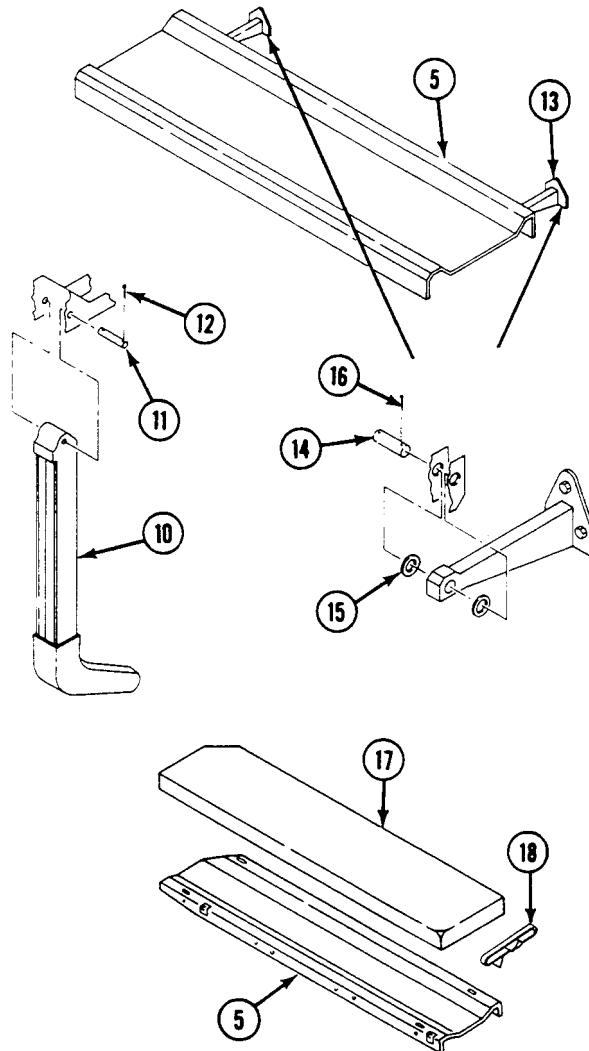

END OF TASK

REPLACE PERSONNEL SEATS, CUSHIONS, AND BELTS (M577A3 ONLY)

0547 00

THIS WORK PACKAGE COVERS:

Removal (page 0547 00-1).
 Installation (page 0547 00-3).

INITIAL SETUP:

Maintenance Level

Unit

Personnel Required

Unit Mechanic

Tools and Special Tools

General Mechanic's Tool Kit (WP 0926 00, Item 65)

References

See your -10

Materials/Parts

Cotter pin (6)
 Locknut (2)

Equipment Condition

Engine stopped (see your -10)
 Carrier blocked (see your -10)
 Ramp lowered (see your -10)

REMOVAL

NOTE

There are two personnel seats in the M577A3 carriers. Remove and install both seats the same way.

1. Remove two cotter pins (1), four washers (2), two headed pins (3), and seat (4) from two brackets (5). Discard cotter pins.
2. Remove four screws (6), washers (7), and two brackets (5) from sponson.
3. Remove two locknuts (8), washers (9), screws (10), and seatbelt (11) from seat (4). Discard locknuts.

NOTE

Remove two washers (9) on two center positions on right seat.

4. Remove four cotter pins (12), two straight pins (13), and two legs (14) from seat (4). Discard cotter pins.

5. Remove two straps (15) and cushion (16) from seat (4).

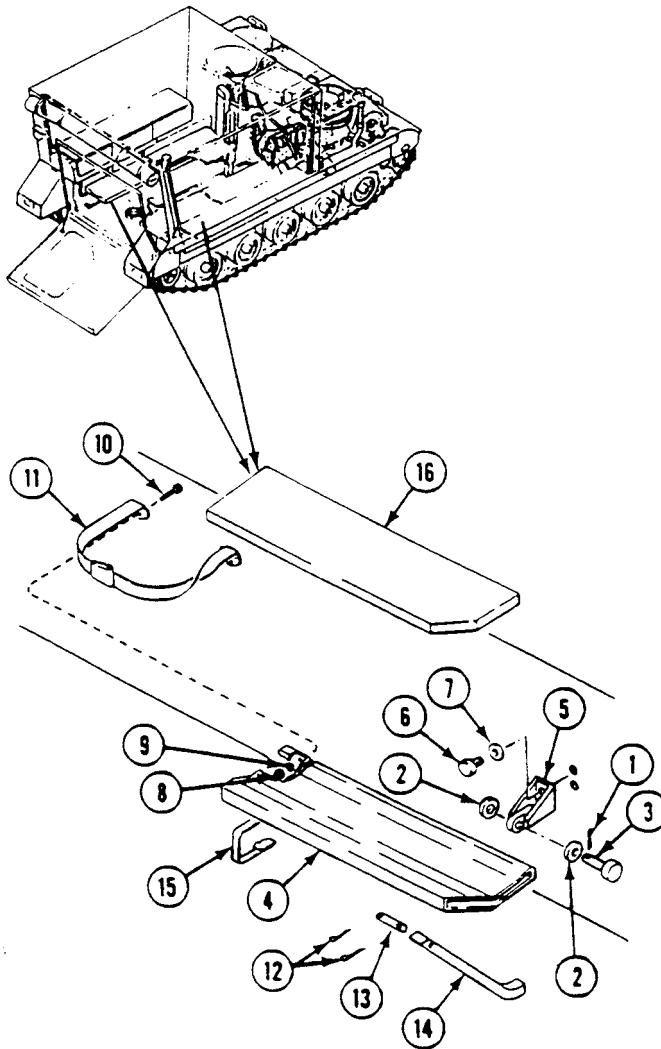

INSTALLATION

1. Place cushion (1) on seat (2). Secure with two straps (3).
2. Align two legs (4) with seat (2). Secure with two straight pins (5) and four new cotter pins (6).
3. Place seatbelt (7) on seat (2). Secure with two screws (8), washers (9), and new locknuts (10).

NOTE

Install two washers (9) on two center positions on right seat (2).

4. Align two brackets (11) with sponson. Secure with four washers (12) and screws (13).
5. Align seat (2) with two brackets (11). Secure with two headed pins (14), four washers (15), and two new cotter pins (16).

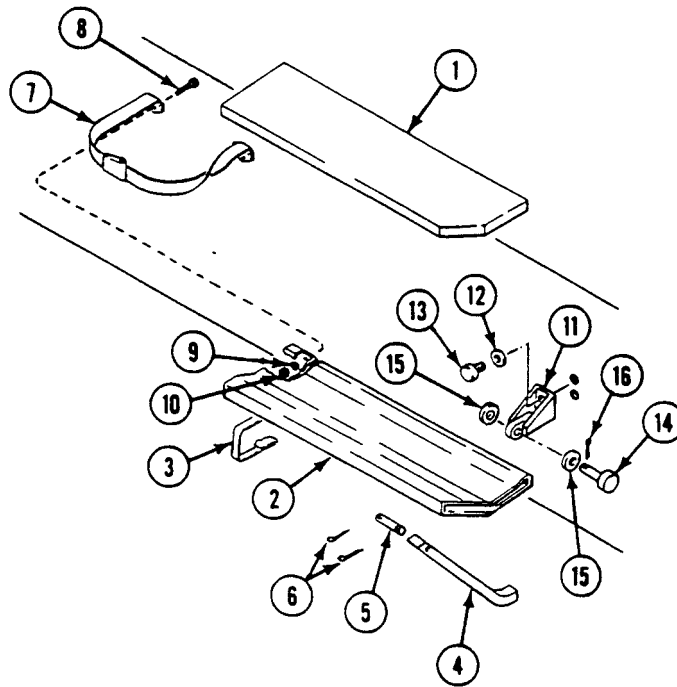

FOLLOW-THROUGH STEPS

1. Start engine (see your -10).
2. Raise and lock ramp (see your -10).
3. Stop engine (see your -10).

END OF TASK

**REPLACE PERSONNEL SEATS, BACKRESTS, CUSHIONS, AND BELTS
(M1059A3 ONLY)**

0549 00

THIS WORK PACKAGE COVERS:

Removal (page 0549 00-1).
Installation (page 0549 00-3).

INITIAL SETUP:

Maintenance Level

Unit

Personnel Required

Unit Mechanic

Tools and Special Tools

General Mechanic's Tool Kit (WP 0926 00, Item 65)

References

See your -10

Materials/Parts

Cotter pin, per seat (8)
Locknut, per seat (2)
Locknut, per seatbelt (2)
Rivet, per strap

Equipment Condition

Engine stopped (see your -10)
Carrier blocked (see your -10)
Ramp lowered (see your -10)

REMOVAL

NOTE

There are two personnel seats and two backrests in the M1059A3 vehicle. Remove and install the seats and backrests in the same way.

1. Remove two locknuts (1), screws (2), and backrest (3) from sponson brackets. Discard locknuts.
2. Remove four cotter pins (4), washers (5), two straight pins (6), and seat (7) from sponson brackets. Discard cotter pins.
3. Remove four cotter pins (8), two straight pins (9), and two legs (10) from seat (7). Discard cotter pins.
4. Remove two locknuts (11), washers (12), screws (13), and seatbelt (14) from each position on seat (7). Discard locknuts.
5. Remove two straps (15) and cushion (16) from seat (7).

NOTE

There are two straps on the long backrest and one strap on the short backrest. All straps are removed in the same way.

6. If needed, remove rivet (17), washer (18), and strap (19) from backrest (3). Discard rivet.

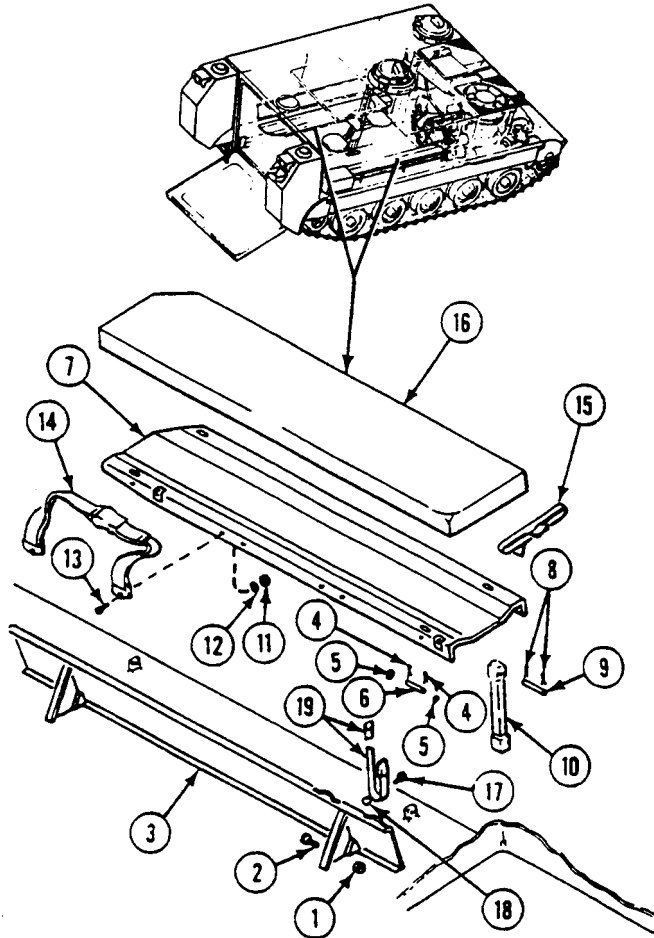

REPLACE PERSONNEL SEATS, BACKRESTS, CUSHIONS, AND BELTS (M1059A3 ONLY) — Continued

0549 00

INSTALLATION

1. If removed, install strap (1) on backrest (2). Secure with washer (3) and new rivet (4).
2. Place cushion (5) on seat (6). Secure with two straps (7).
3. Place seatbelt (8) for each position on seat (6). Secure with two screws (9), washers (10), and new locknuts (11).
4. Align two legs (12) with seat (6). Secure with two straight pins (13) and four new cotter pins (14).
5. Align seat (6) with sponson brackets. Secure with two straight pins (15), four washers (16), and four new cotter pins (17).
6. Align backrest (2) with sponson brackets. Secure with two screws (18) and two new locknuts (19).

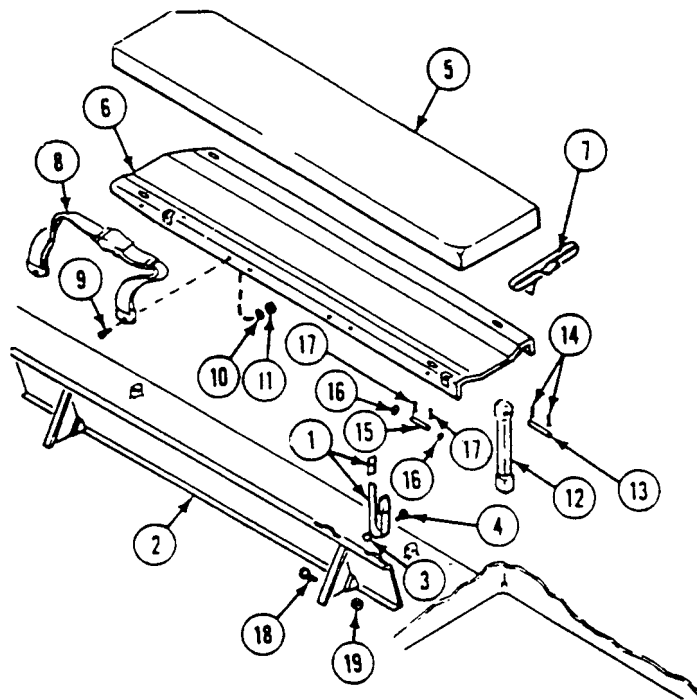

FOLLOW-THROUGH STEPS

1. Start engine (see your -10).
2. Raise and lock ramp (see your -10).
3. Stop engine (see your -10).

END OF TASK

**REPLACE PERSONNEL SEATS, BACKRESTS, CUSHIONS, AND BELTS
(M1064A3 ONLY)**

0550 00

THIS WORK PACKAGE COVERS:

Removal (page 0550 00-1).
Installation (page 0550 00-3).

INITIAL SETUP:

Maintenance Level

Unit

Personnel Required

Unit Mechanic

Tools and Special Tools

General Mechanic's Tool Kit (WP 0926 00, Item 65)
Hand Blind Riveter (WP 0926 00, Item 44)

References

See your -10

Materials/Parts

Cotter pin (10)
Locknut (4)
Rivet

Equipment Condition

Engine stopped (see your -10)
Carrier blocked (see your -10)
Ramp lowered (see your -10)

REMOVAL

1. Remove two cotter pins (1), washers (2), headed pins (3), and backrest (4) from mounting lugs. Discard cotter pins.

NOTE

Do Steps 2 - 6 for left seat only.

2. Remove four cotter pins (5), washers (6), two straight pins (7), and seat (8) from sponson brackets. Discard cotter pins.
3. Remove four cotter pins (9), two straight pins (10), and two legs (11) from seat (8). Discard cotter pins.
4. Remove four locknuts (12), washers (13), screws (14), and two seat belts (15) from seat (8). Discard locknuts.
5. Remove two straps (16) and cushion (17) from seat (8).

REPLACE PERSONNEL SEATS, BACKRESTS, CUSHIONS, AND BELTS (M1064A3 ONLY) — Continued

0550 00

6. If needed, remove rivet (18), washer (19), and strap (20) from backrest (4). Discard rivet.

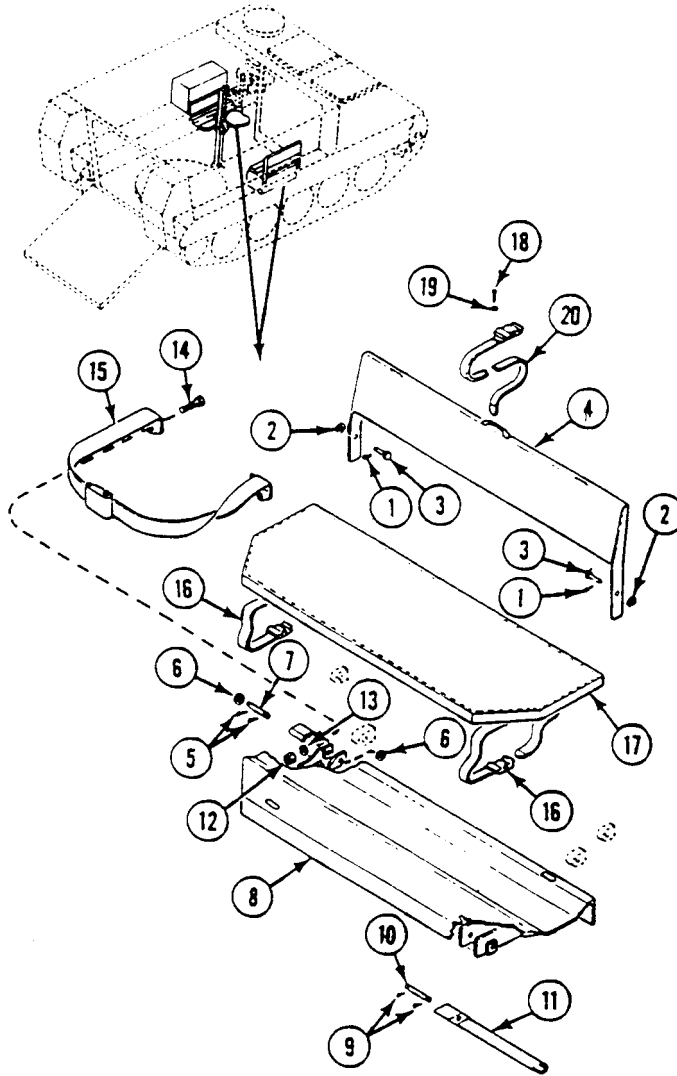

NOTE

Do Step 7 and Step 8 for right seat only.

7. Remove two straps (1) and cushion (2) from battery box cover (3).

REPLACE PERSONNEL SEATS, BACKRESTS, CUSHIONS, AND BELTS (M1064A3 ONLY) — Continued

0550 00

8. Remove four screws (4), lockwashers (5), and two seat belts (6) from battery box (7). Discard lockwashers.

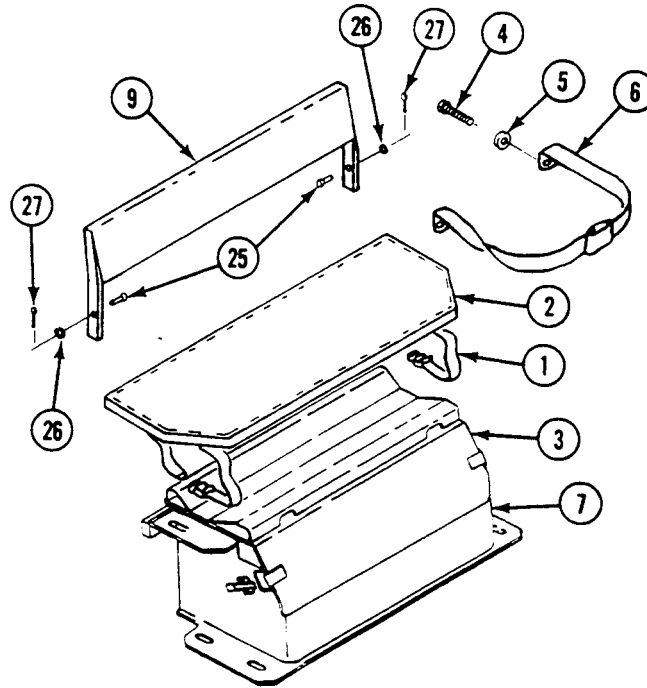

INSTALLATION

NOTE

Do Step 1 and Step 2 for right seat only.

1. Install two seat belts (6) on battery box (7) and secure with four screws (4) and new lockwashers (5).

REPLACE PERSONNEL SEATS, BACKRESTS, CUSHIONS, AND BELTS (M1064A3 ONLY) — Continued

0550 00

2. Place cushion (2) on battery box cover (3). Secure with two straps (1).

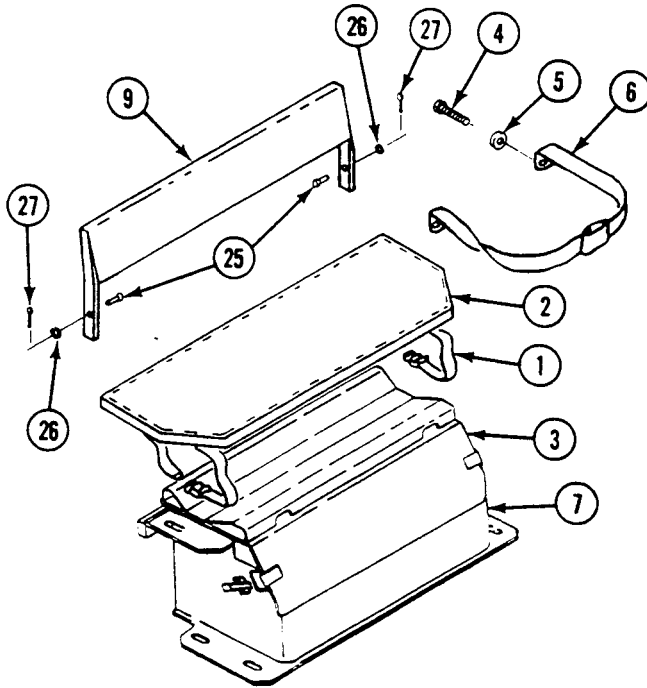

REPLACE PERSONNEL SEATS, BACKRESTS, CUSHIONS, AND BELTS (M1064A3 ONLY) — Continued

0550 00

NOTE**Do Steps 3 - 7 for left seat only.**

3. If removed, install strap (8) on backrest (9). Secure with washer (10) and new rivet (11).
4. Place cushion (12) on seat (13). Secure with two straps (14).
5. Place two seat belts (15) on seat (13). Secure with four screws (16), washers (17), and new locknuts (18).
6. Align two legs (19) with mounting holes in seat (13). Secure with two straight pins (20) and four new cotter pins (21).
7. Align seat (13) with sponson brackets. Secure with two straight pins (22), four washers (23), and four new cotter pins (24).
8. Align backrest (9) with mounting lugs. Secure with two headed pins (25), washers (26), and two new cotter pins (27).

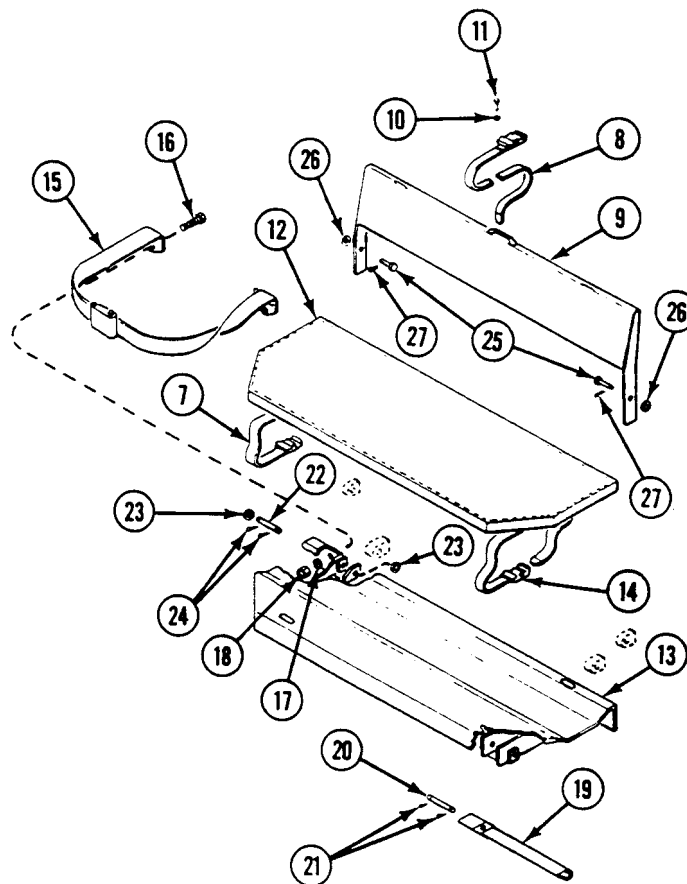
**FOLLOW-THROUGH STEPS**

1. Start engine (see your -10).
2. Raise and lock ramp (see your -10).
3. Stop engine (see your -10).

END OF TASK

REPLACE DRIVER'S SEAT ASSEMBLY

0551 00

THIS WORK PACKAGE COVERS:

Removal (page 0551 00-1).
 Installation (page 0551 00-2).

INITIAL SETUP:

Maintenance Level

Unit

Personnel Required

Unit Mechanic

Tools and Special Tools

General Mechanic's Tool Kit (WP 0926 00, Item 65)

References

See your -10

Materials/Parts

Locknut (2)
 Washer (as needed)

Equipment Condition

Engine stopped (see your -10)
 Carrier blocked (see your -10)

REMOVAL

1. Remove four screws (1) and washers (2) from seat mounting plate (3) and absorber (4).
2. Remove two screws (5), locknuts (6), and seat lock rack (7) from seat mounting plate (3). Discard locknuts.
3. Slide mounting plate (3) out of seat rails (8).

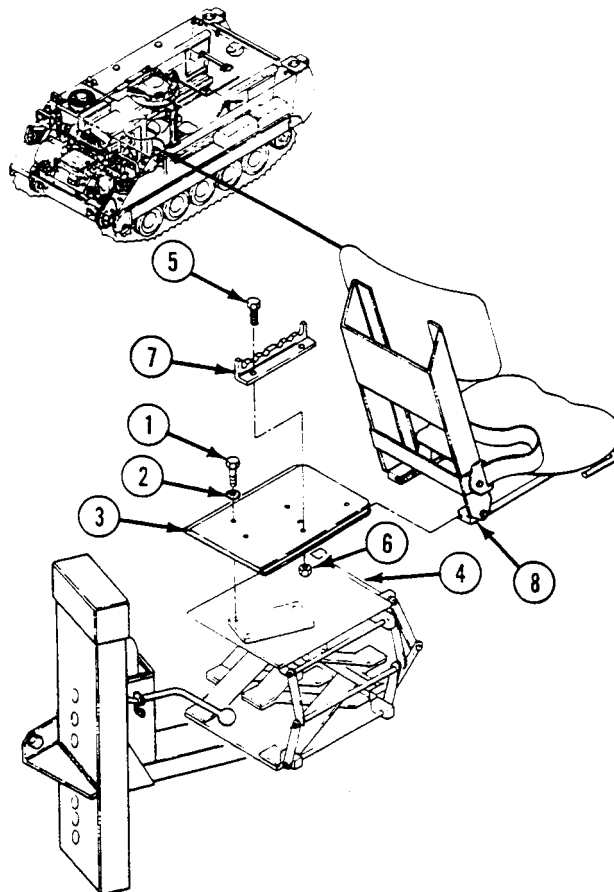

INSTALLATION**NOTE**

Use washers as shims in front two holes between absorber and plate to ensure proper fit.

1. Slide mounting plate (3) into seat rails (8).
2. Install seat lock rack (7) on mounting plate (3). Secure with two screws (5) and new locknuts (6).
3. Install seat assembly on absorber (4). Align holes in seat mounting plate (3) with threaded holes in absorber. Secure with four screws (1) and washers (2).

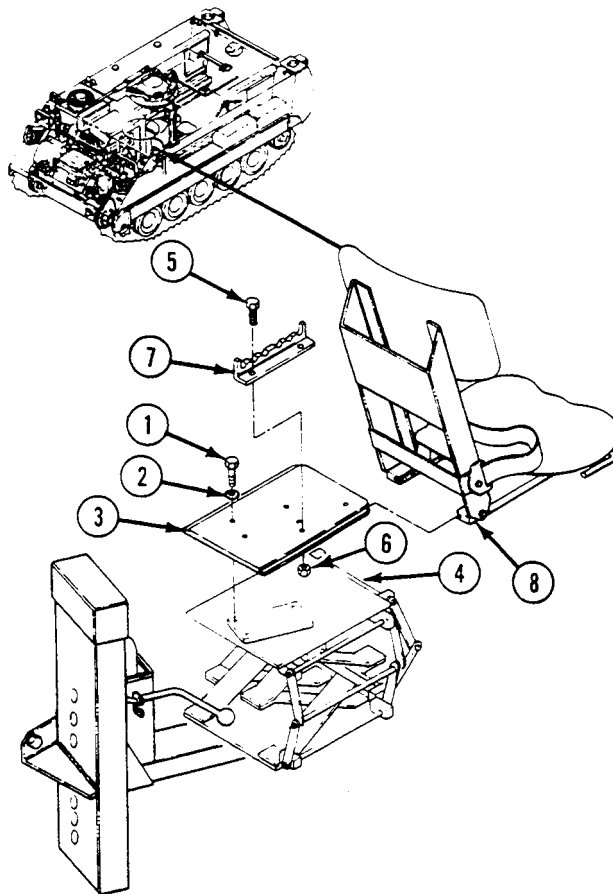
**FOLLOW-THROUGH STEPS**

1. Check seat and lock for proper operation.

END OF TASK

REPAIR DRIVER'S SEAT

0552 00

THIS WORK PACKAGE COVERS:

Disassembly (page 0552 00-1).
 Assembly (page 0552 00-2).

INITIAL SETUP:

Maintenance Level

Unit

Personnel Required

Unit Mechanic

Tools and Special Tools

General Mechanic's Tool Kit (WP 0926 00, Item 65)

References

See your -10

Materials/Parts

Locknut (14)
 Spring pin (4)

Equipment Condition

Driver's seat back assembly removed (WP 0553 00)
 Driver's seat assembly removed (WP 0551 00)

DISASSEMBLY

1. Unhook cord (1) and remove cushion (2) from seat (3).
2. Remove two screws (4), washers (5), and spacers (6) from support (7).
3. Remove six screws (8), locknuts (9), washers (10), and two flanges (11) from seat (3). Discard locknuts.
4. Remove eight screws (12), locknuts (13), rails (14), and brace (15) from seat (3). Discard locknuts.

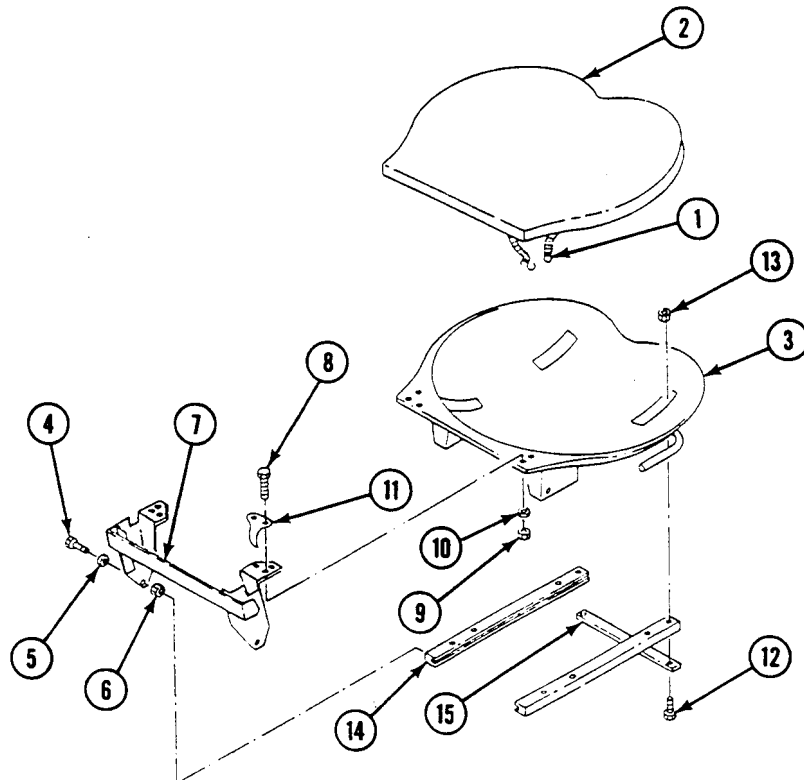

5. Remove spring pin (1) from latch (2) and lever (3). Remove latch and lever from seat (4). Discard spring pin.

6. Remove spring (5) and spring pin (6) from lever (3). Discard spring pin.
7. Remove two spring pins (7) and (8) from seat (4). Discard spring pins.

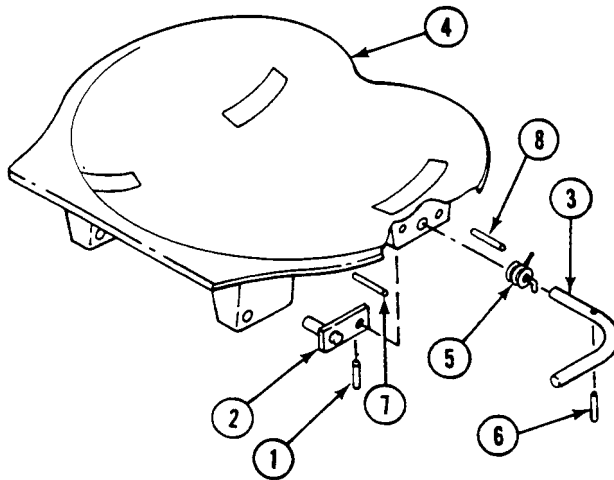

ASSEMBLY

NOTE

Forward pin protrudes outboard and aft pin protrudes inboard.

1. Install two new spring pins (7) and (8) in seat (4).
2. Install new spring pin (6) in lever (3), and install spring (5) on lever (3).
3. Install lever (3) in seat (4). Place latch (2) on lever and secure with new spring pin (1).

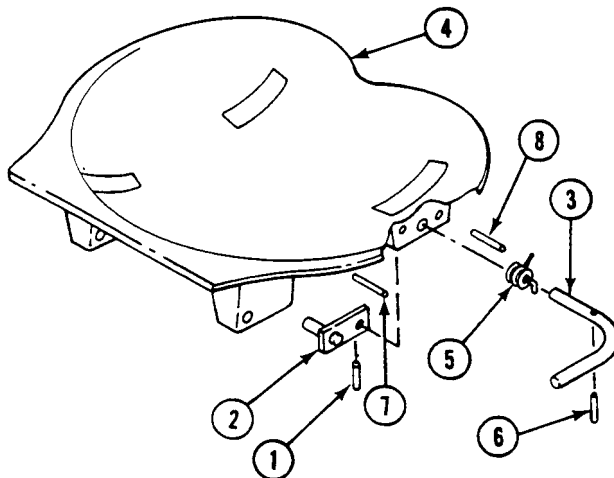

NOTE

Connect brace to the two forward holes of the rails.

4. Install rails (9) and brace (10) on seat (4). Secure with eight screws (11) and new locknuts (12).
5. Align holes between rails (9) and support (13). Place spacers (14) between rails (9) and support (13), and secure with two screws (15) and washers (16).
6. Place right and left flanges (17) on support (13). Secure to seat (4) with six screws (18), new locknuts (19), and washers (20).
7. Place cushion (21) on seat (4) and connect hooks on cord (22).

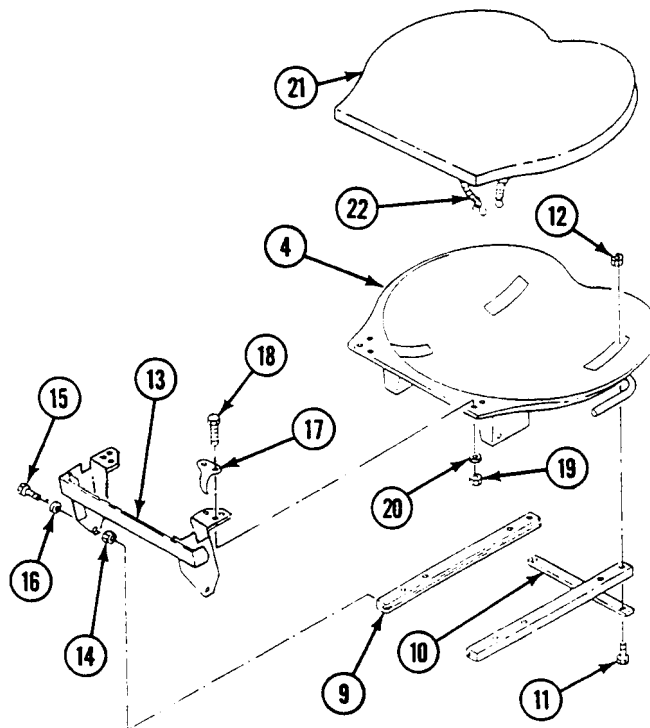
**FOLLOW-THROUGH STEPS**

1. Install driver's seat assembly (WP 0551 00).
2. Install driver's seat back assembly (WP 0553 00).

END OF TASK

REPLACE DRIVER'S SEAT BACK ASSEMBLY

0553 00

THIS WORK PACKAGE COVERS:

Removal (page 0553 00-1).
 Installation (page 0553 00-2).

INITIAL SETUP:

Maintenance Level

Unit

References

See your -10

Tools and Special Tools

General Mechanic's Tool Kit (WP 0926 00, Item 65)

Equipment Condition

Personnel Required

Unit Mechanic

Engine stopped (see your -10)

Carrier blocked (see your -10)

REMOVAL

1. Push driver's seat back assembly (1) forward against spring tension of flanges (2), and lift seat back assembly from seat (3).

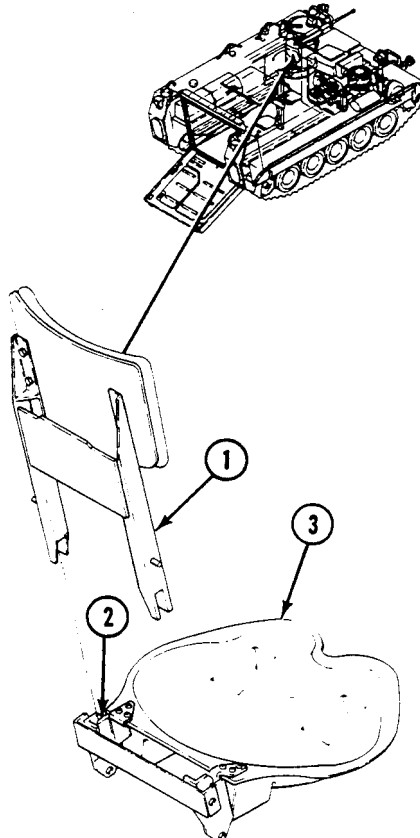

INSTALLATION

1. Push seat back assembly (1) down into seat (3) until it locks into position.

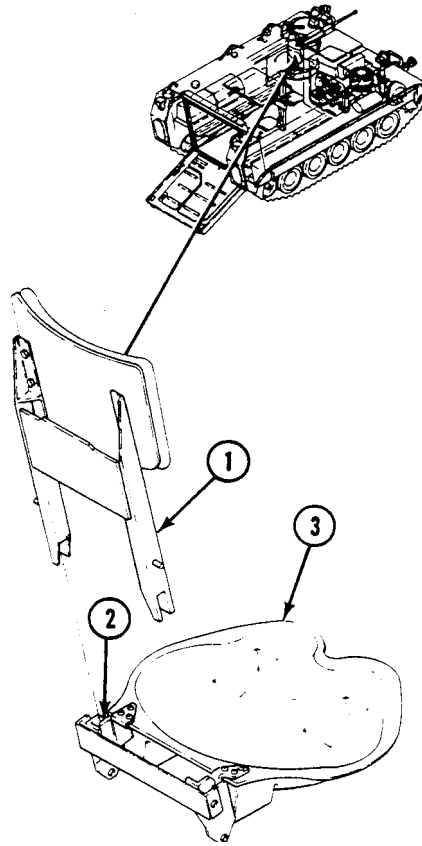
**END OF TASK**

REPAIR DRIVER'S SEAT BACK ASSEMBLY

0554 00

THIS WORK PACKAGE COVERS:

Removal (page 0554 00-1).
 Installation (page 0554 00-1)

INITIAL SETUP:

Maintenance Level

Unit

References

See your -10

Tools and Special Tools

General Mechanic's Tool Kit (WP 0926 00, Item 65)

Equipment Condition

Engine stopped (see your -10)

Personnel Required

Unit Mechanic

Carrier blocked (see your -10)

Driver's seat back assembly removed (WP 0553 00)

DISASSEMBLY

1. Remove four screws (1), washers (2), and backrest (3) from support (4).

ASSEMBLY

1. Install backrest (3) on support (4). Secure with four screws (1) and washers (2).

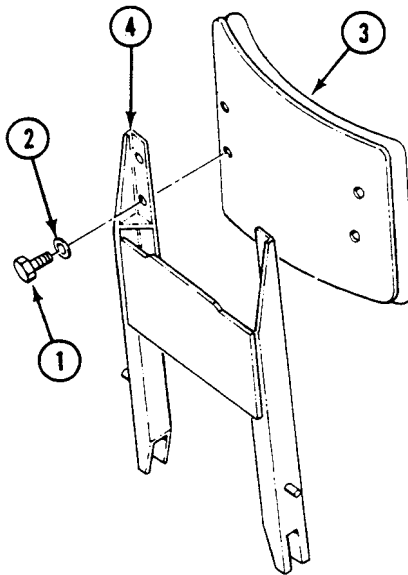

FOLLOW-THROUGH STEPS

1. Install seat backrest assembly (WP 0553 00).

END OF TASK

REPLACE DRIVER'S SEAT IMPACT ABSORBER

0555 00

THIS WORK PACKAGE COVERS:

Removal (page 0555 00-1).
 Installation (page 0555 00-1).

INITIAL SETUP:

Maintenance Level

Unit

References

See your -10

Tools and Special Tools

General Mechanic's Tool Kit (WP 0926 00, Item 65)

Equipment Condition

Engine stopped (see your -10)

Personnel Required

Unit Mechanic

Carrier blocked (see your -10)

Driver's seat assembly removed (WP 0551 00)

REMOVAL

1. Remove four screws (1) from absorber (2) and post assembly (3). Remove absorber.

INSTALLATION

1. Install absorber (2) on post assembly (3). Secure with four screws (1).

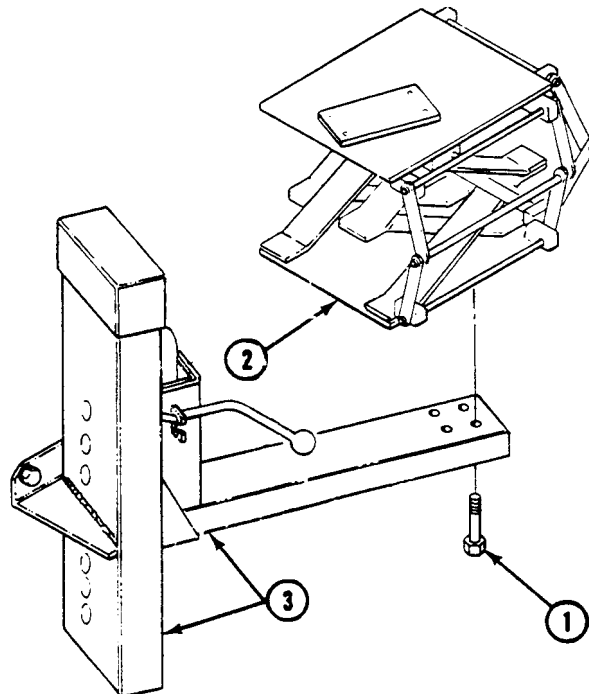

FOLLOW-THROUGH STEPS

1. Install driver's seat assembly (WP 0551 00).

END OF TASK

REPLACE DRIVER'S SEAT POST ASSEMBLY

0556 00

THIS WORK PACKAGE COVERS:

Removal (page 0556 00-1).
 Installation (page 0556 00-2).

INITIAL SETUP:

Maintenance Level

Unit

References

See your -10

Tools and Special Tools

General Mechanic's Tool Kit (WP 0926 00, Item 65)

Equipment Condition

Engine stopped (see your -10)

Materials/Parts

Locknuts (2)

Carrier blocked (see your -10)

Personnel Required

Unit Mechanic

Driver's seat assembly removed (WP 0551 00)

Helper (H)

Driver's seat impact absorber removed (WP 0555 00)

REMOVAL

1. Remove bumper (1), two screws (2), and locknuts (3) from lower support bracket (4). Discard locknuts.
2. Support post assembly (5) and remove two screws (6), washers (7), and strip (8) from post assembly and sponson bracket (9). Remove post assembly from carrier. Have helper assist.

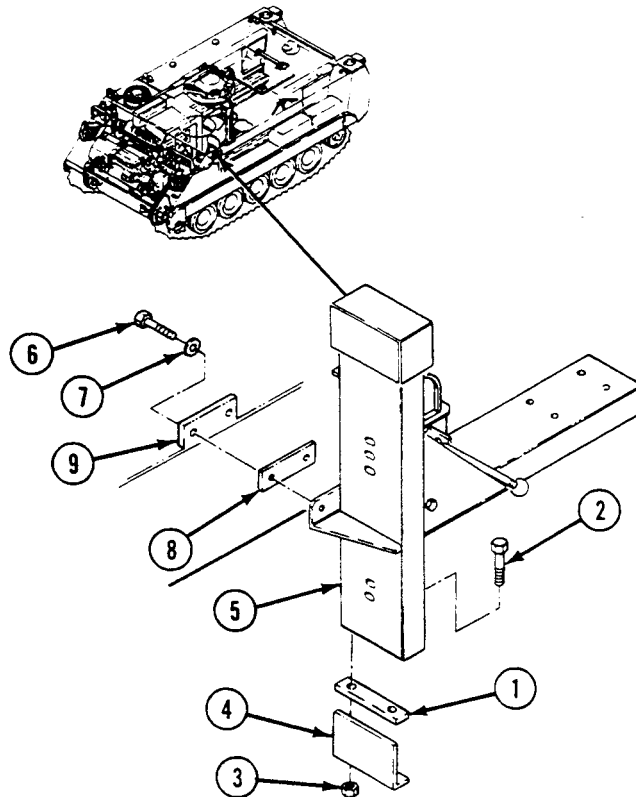

INSTALLATION

1. Place post assembly (5) on lower bracket (4) and against sponson bracket (9). Secure post to sponson bracket with two screws (6), washers (7), and strip (8).
2. Secure lower end of post assembly (5) to lower bracket (4) with two screws (2) and new locknuts (3).
3. Install bumper (1) inside post (5).

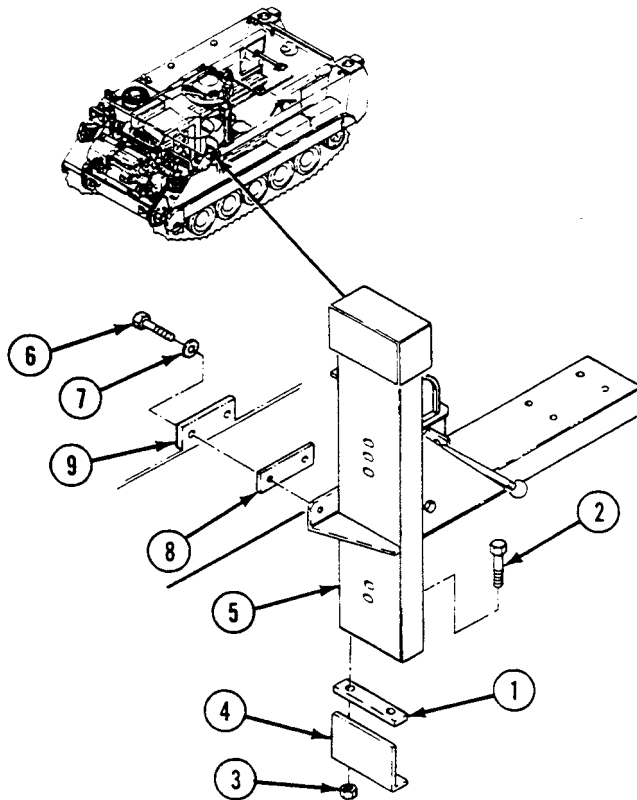
**FOLLOW-THROUGH STEPS**

1. Install driver's seat impact absorber (WP 0555 00).
2. Install driver's seat assembly (WP 0551 00)

END OF TASK

REPAIR DRIVER’S SEAT POST ASSEMBLY

0557 00

THIS WORK PACKAGE COVERS:

Disassembly (page 0557 00-1).
 Assembly (page 0557 00-4).

INITIAL SETUP:

Maintenance Level

Unit

Personnel Required

Unit Mechanic

Tools and Special Tools

General Mechanic’s Tool Kit (WP 0926 00, Item 65)
 Retaining Ring Pliers Set (WP 0926 00, Item 32)

References

See your -10

Materials/Parts

Cotter pin
 Locknut (4)
 Locknut (2)
 Locknut (4)
 Spring pin (4)

Equipment Condition

Engine stopped (see your -10)
 Carrier blocked (see your -10)
 Driver’s seat assembly removed (WP 0551 00)
 Driver’s seat impact absorber removed (WP 0555 00)
 Driver’s seat post assembly removed (WP 0556 00)

DISASSEMBLY

1. Lower seat support (1) to bottom hole. Remove cap (2), two screws (3), locknuts (4), and stiffener (5) from post (6). Discard locknuts.
2. Remove four screws (7), washers (8), lock nuts (9), two spacers (10), and plate (11) from post (6). Discard locknuts.

3. Hold crank (12) up and slide adjuster (13) up and out of post (6).

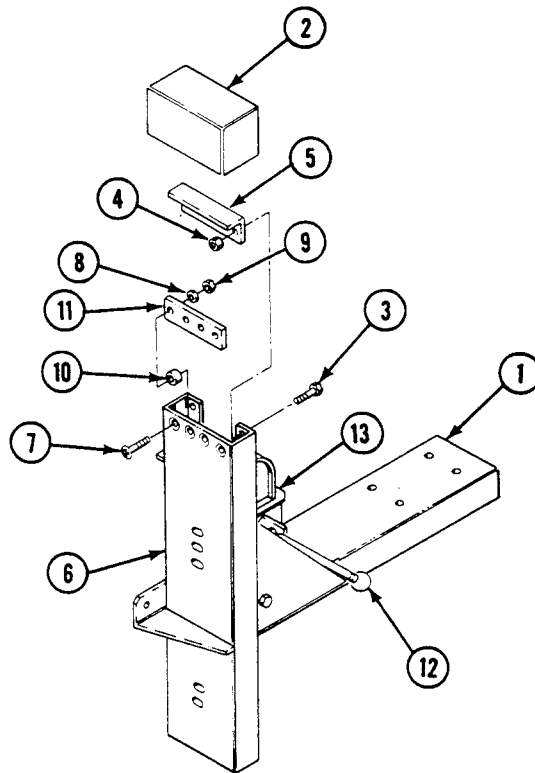

4. Remove four screws (1), washers (2), locknuts (3), and support (4) from adjuster (5). Discard locknuts.
5. Remove screw (6), washer (7), and spring cover (8) from adjuster (5). Remove cover.

6. Remove cotter pin (9), washer (10), pin (11), washer (10), and spool (12) with two springs (13) from adjuster (5). Remove springs from spool. Discard cotter pin.

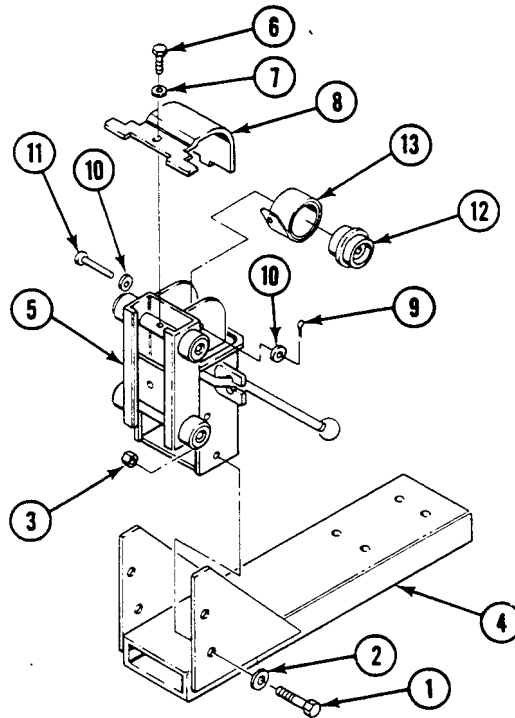

7. Remove four snap rings (14) and rollers (15).
8. Work through slot on top of adjuster (5), and remove two spring pins (16) from cam (17). Remove crank (18). Discard spring pins.
9. Compress spring (19) against wall of adjuster (5). Remove two spring pins (20) from stop pin (21). Remove stop pin, two washers (22), and cam (17) from inside adjuster. Discard spring pins.
10. Remove spring (19) and washer (23) from adjuster (5).

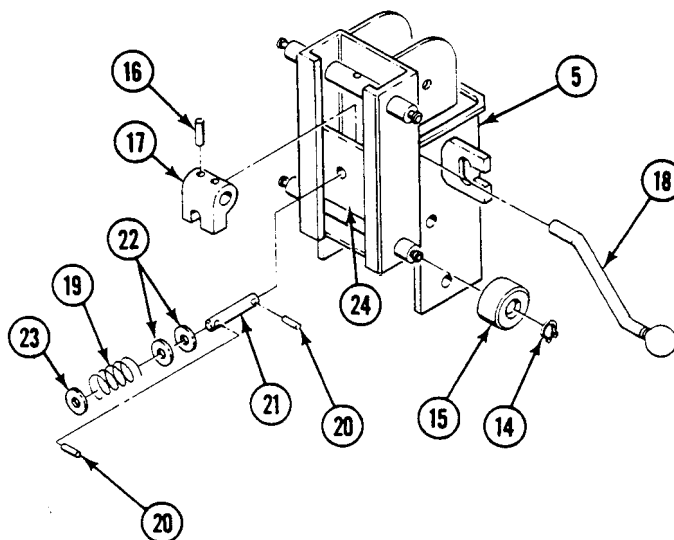

ASSEMBLY

1. Place crank (18) in adjuster (5) and install cam (17). Secure with two new spring pins (16).
2. Align spring (19) and two washers (22) with holes of stiffener (24) and adjuster (5).
3. Install new spring pin (20) in hole closest to end of stop pin (21). Install two washers (22) on stop pin from other end and push up against spring pin. Slide stop pin through slot in cam (17), hole in housing, and spring (20), washer (23), and into hole in stiffener (24).
4. Compress spring (19) against wall of adjuster (5) and install new spring pin (20) outboard of washers (22). Check operation of crank (18) and stop pin.
5. Install four rollers (15) on shaft of adjuster (5) and secure with four snap rings (14).

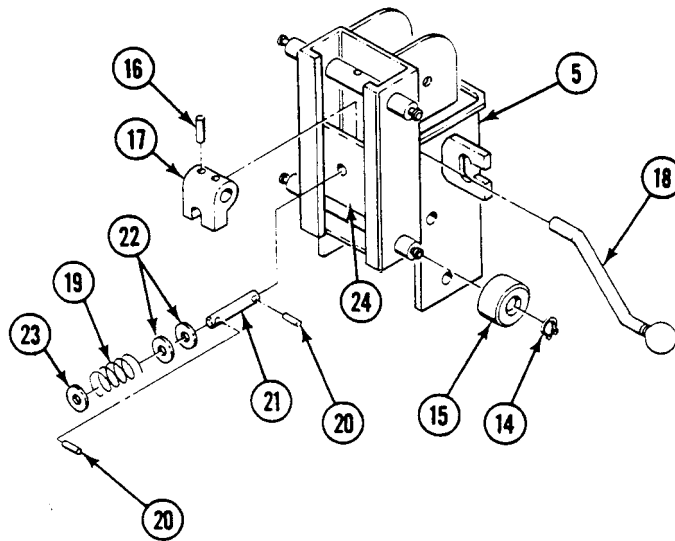

6. Install two springs (1) on spool (2) and install on top of adjuster (3). Install pin (4) through spool. Secure with new cotter pin (5) and two washers (6).
7. Pry out two springs (1) and route under upper roller shaft. Extend springs 2 to 3 inches beyond roller shaft.
8. Install spring cover (7) on adjuster (3). Secure with one screw (8) and washer (9).
9. Place lower roller (10) inside top of post (11). Raise crank (12) and slide adjuster (3) down into post until holes in post line up with holes in springs (1).

10. Install support (13) on adjuster (3). Secure with four screws (14), washers (15), and new locknuts (16).

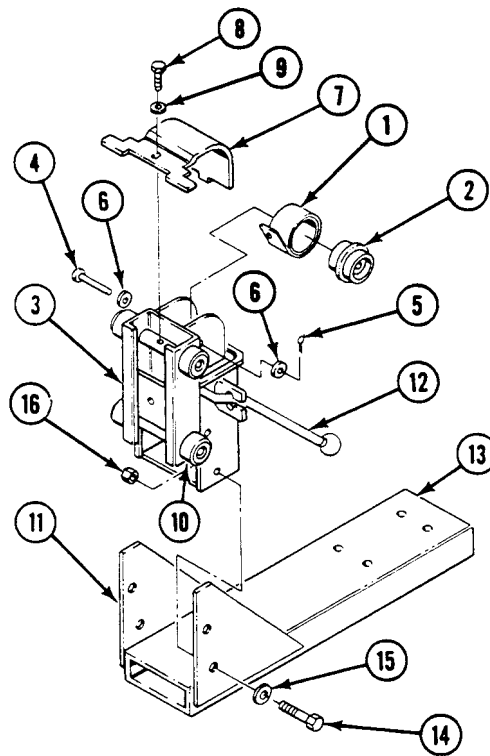

11. Install two screws (17) into inboard holes and install plate (18) to post (19) with two screws (17), washers (20), and new locknuts (21). Tighten locknuts two turns only at this time.
12. Place spacers (22) between post (19) and plate (18) at the outboard holes. Install two screws (17) through spacers and plate. Secure with two washers (20) and new locknuts (21).

CAUTION

Take care not to tighten the locknuts too tight or the plate will bend.

13. Tighten two locknuts (21), installed in Step 11 above, just enough to bottom against plate (18).

14. Lower seat support (13) all the way down. Place stiffener (23) in post and install cap (24). Secure with two screws (25) and new locknuts (26).

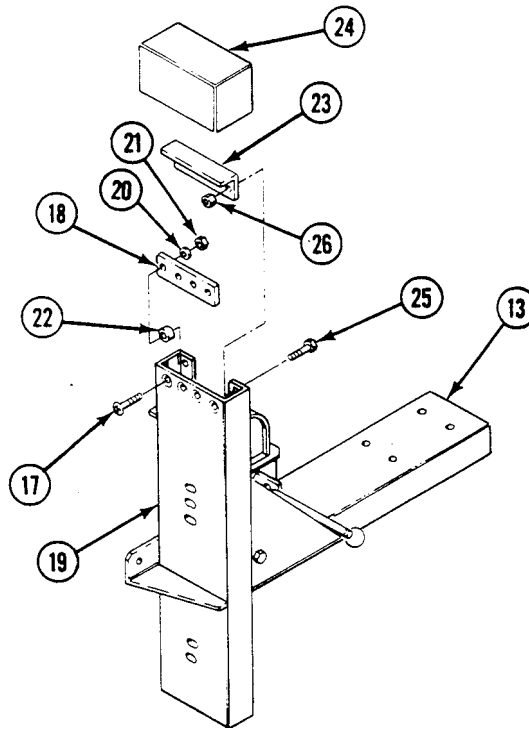

FOLLOW-THROUGH STEPS

1. Install driver's seat post assembly (WP 0556 00).
2. Install driver's seat impact absorber (WP 0555 00).
3. Install driver's seat assembly (WP 0551 00).

END OF TASK

REPLACE DRIVER'S FOOTREST

0558 00

THIS WORK PACKAGE COVERS:

Removal (page 0558 00-1).
 Installation (page 0558 00-1).

INITIAL SETUP:

Maintenance Level

Unit

References

See your -10

Tools and Special Tools

General Mechanic's Tool Kit (WP 0926 00, Item 65)

Materials/Parts

Locknut (2)

Equipment Condition

Engine stopped (see your -10)

Personnel Required

Unit Mechanic

Carrier blocked (see your -10)

REMOVAL

1. Remove two locknuts (1), four washers (2), two screws (3), and footrest (4) from carrier. Discard locknuts.

INSTALLATION

1. Install footrest (4) on hull. Secure with two screws (3), four washers (2), and two new locknuts (1).

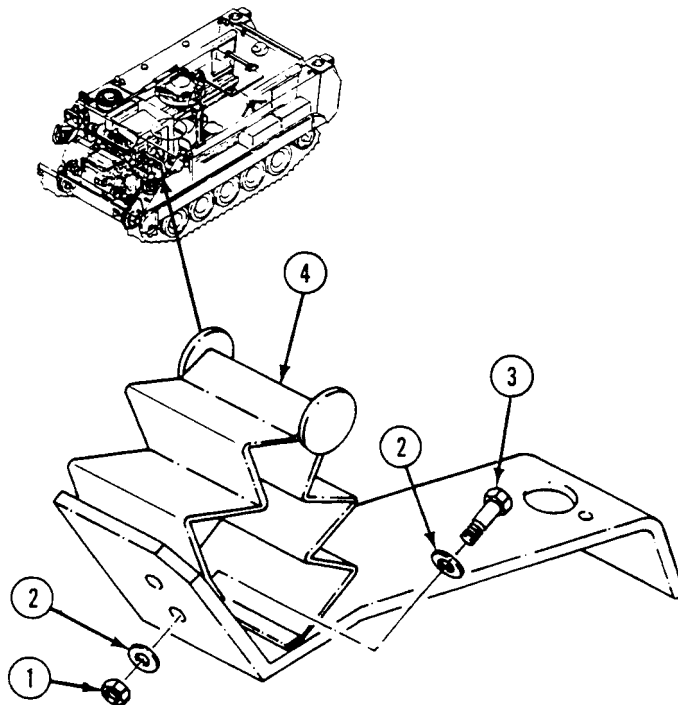

END OF TASK

REPLACE/REPAIR COMMANDER'S PLATFORM (M113A3, M1059A3, M1064A3, AND M58 ONLY)

0559 00

THIS WORK PACKAGE COVERS:

- Removal (page 0559 00-1).
- Disassembly (page 0559 00-2).
- Assembly (page 0559 00-4).
- Installation (page 0559 00-6).

INITIAL SETUP:

Maintenance Level

Unit

Personnel Required

Unit Mechanic

Tools and Special Tools

General Mechanic's Tool Kit (WP 0926 00, Item 65)

References

See your -10

Materials/Parts

- Cotter pin (5)
- Locknut (4)
- Locknut (4)

Equipment Condition

- Engine stopped (see your -10)
 - Carrier blocked (see your -10)
-

REMOVAL

1. Remove hold-down strap (1) from right front floor plate and platform (2).

REPLACE/REPAIR COMMANDER'S PLATFORM (M113A3, M1059A3, M1064A3, AND M58 ONLY) — Continued

0559 00

2. Remove quick-release pin (3) and platform (2) from seat post (4).

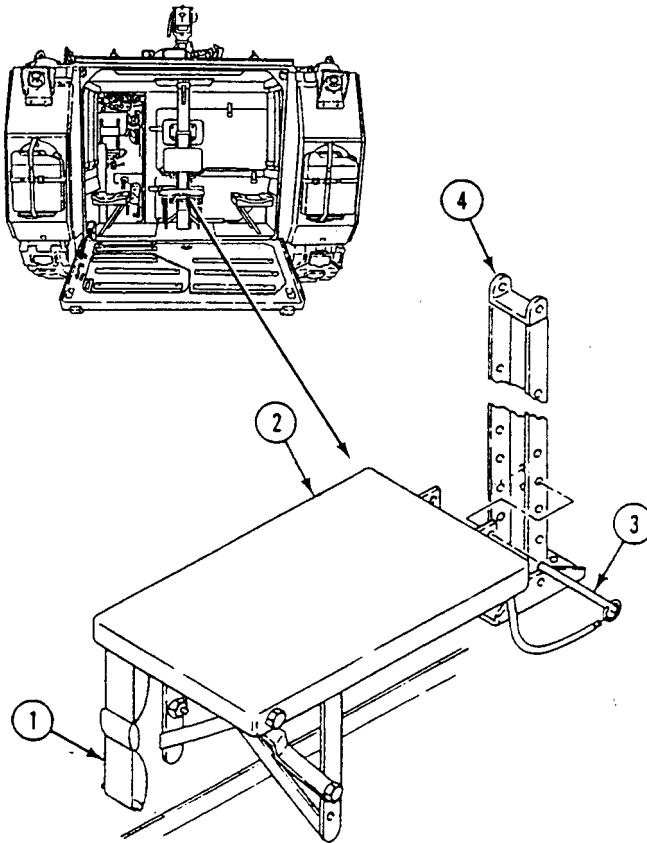
**DISASSEMBLY**

1. Open both ends of hook (5) and remove from quick-release pin (3) and chain (6).
2. Remove tube (7) from chain (6).
3. Open both ends of hook (8). Remove from chain (6) and platform (2).
4. Remove spring (9) from cotter pin (10) and platform (2).

REPLACE/REPAIR COMMANDER'S PLATFORM (M113A3, M1059A3, M1064A3, AND M58 ONLY) — Continued

0559 00

- Remove cotter pin (10) from two supports (11). Discard cotter pin.

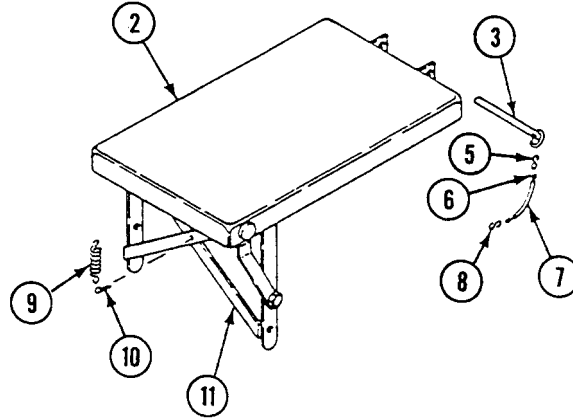

- Remove four locknuts (1), screws (2), six washers (3), and two braces (4) from platform (5) and two posts (6), (7). Discard locknuts.
- Remove two posts (6), (7) from platform (5). Remove two locknuts (8), screws (9), and post (6) from two supports (10). Discard locknuts.

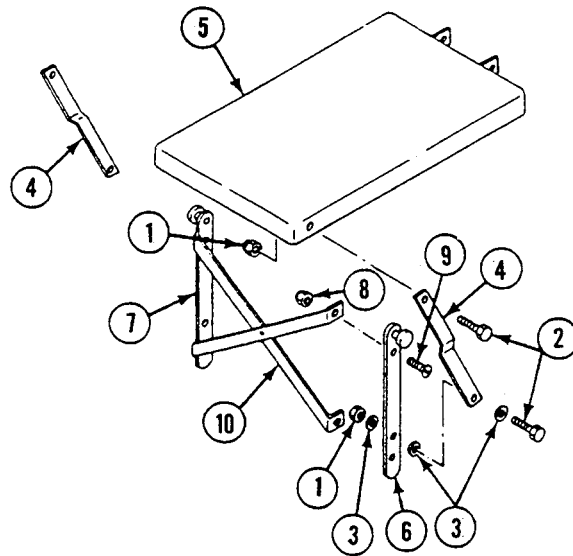

NOTE

Do Step 8 for M1064A3 only.

8. Remove four cotter pins (11), washers (12), pins (13), and two plates (14) from platform (5). Discard cotter pins.

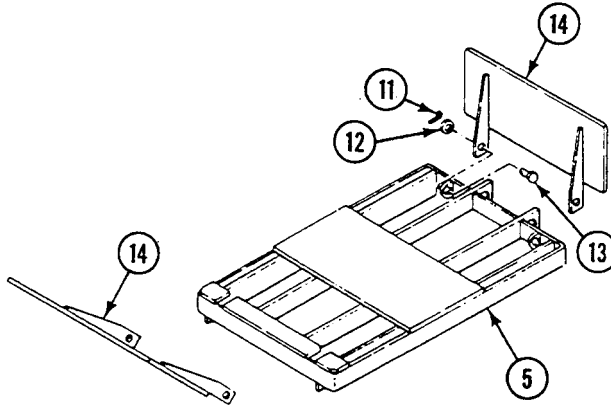

ASSEMBLY

NOTE

Do Step 1 for M1064A3 only.

1. Align two plates (14) with platform (5). Secure with four pins (13), washers (12), and new cotter pins (11).
2. Install post (6) on two supports (10). Secure with two screws (9) and new locknuts (8). Install two posts (6) and (7) on platform (5).

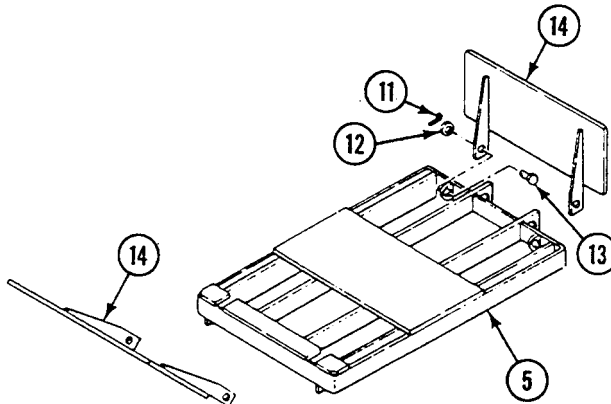

REPLACE/REPAIR COMMANDER'S PLATFORM (M113A3, M1059A3, M1064A3, AND M58 ONLY) — Continued

0559 00

3. Install two braces (4) on posts (6) and (7) and platform (5). Secure with four screws (2), six washers (3), and four new locknuts (1).

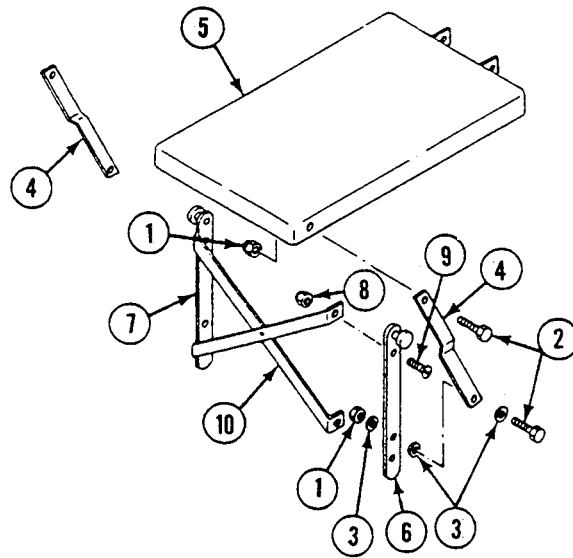

4. Install new cotter pin (1) in two supports (2).
5. Install spring (3) in cotter pin (1) and platform (4).
6. Install hook (5) on platform (4) and chain (6). Squeeze both ends of hook to secure platform and chain.
7. Install tube (7) on chain (6).
8. Install hook (8) on chain (6) and quick-release pin (9). Squeeze both ends of hook to secure chain and pin.

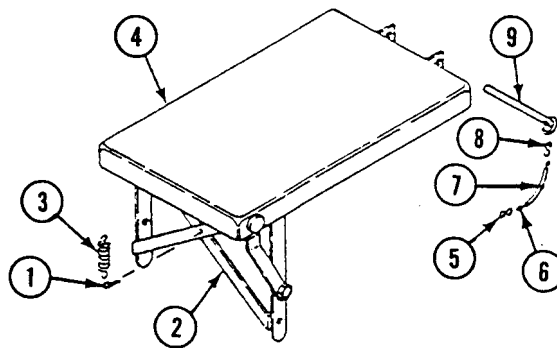

REPLACE/REPAIR COMMANDER'S PLATFORM (M113A3, M1059A3, M1064A3, AND M58 ONLY) — Continued

0559 00

INSTALLATION

1. Align platform (4) with seat post (10). Secure with quick-release pin (9).
2. Install hold-down strap (11) in right front floor plate and platform (4). Tighten strap.

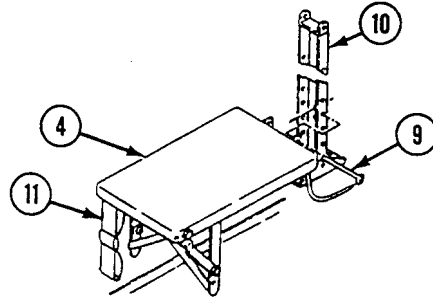
**END OF TASK**

REPLACE COMMANDER'S SEAT AND POST (M113A3, M1059A3, AND M58 ONLY)

0560 00

THIS WORK PACKAGE COVERS:

Removal (page 0560 00-1).
 Installation (page 0560 00-3).

INITIAL SETUP:

Maintenance Level

Unit

Personnel Required

Unit Mechanic

Tools and Special Tools

General Mechanic's Tool Kit (WP 0926 00, Item 65)

References

See your -10

Materials/Parts

Locknut
 Locknut
 Lockwasher

Equipment Condition

Engine stopped (see your -10)
 Carrier blocked (see your -10)
 Commander's platform removed (WP 0559 00)

REMOVAL

1. Unlock seat lock. Remove seat assembly (1) from post (2).

NOTE

Do Step 2 for M113A3 only. M1059A3 and M58 do not have the commander's jump seat.

2. If post (2) is to be replaced, remove commander's jump seat (3) from post (WP 0563 00).

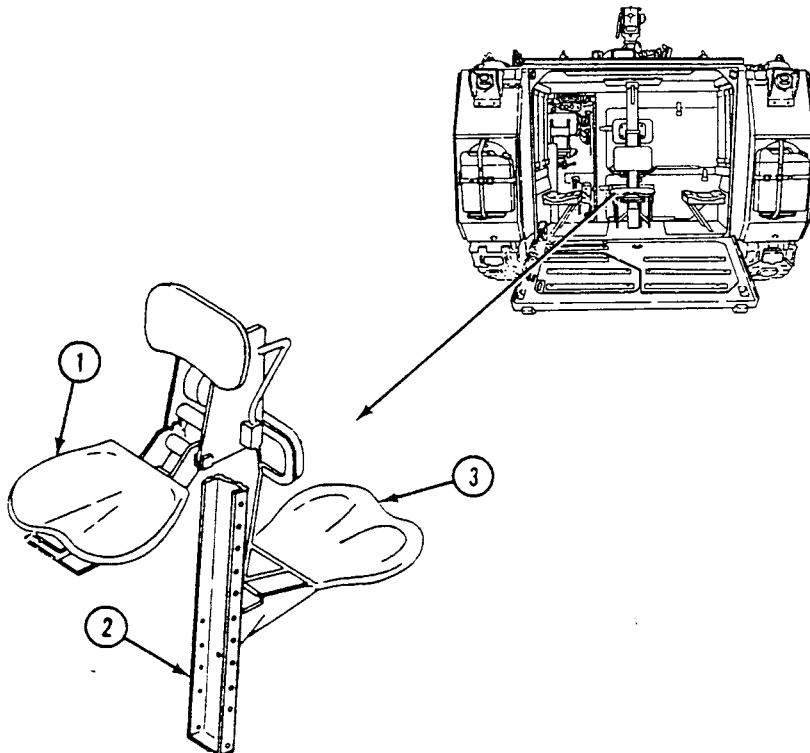

**REPLACE COMMANDER'S SEAT AND POST (M113A3, M1059A3, AND M58 ONLY) —
Continued**

0560 00

3. Remove locknut (4), washer (5), screw (6), and post (2) from base (7). Discard locknut.
4. Remove base (7) from hull crossmember.

NOTE

Do Step 5 for M1059A3 and M58 only.

5. Remove screw (8), lockwasher (9), and nut (10) from post (2). Discard lockwasher.

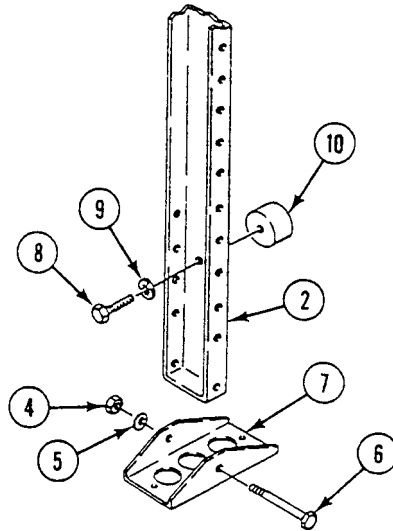

6. Remove quick-release pin (1) from link (2) and hull top plate brackets. Remove seat and post assembly (3) from carrier.
7. Open both ends of hook (4). Remove from pin (1) and chain (5).
8. Remove tube (6) from chain (5).
9. Open both ends of hook (7). Remove hook from chain (5) and bracket (8).
10. Remove locknut (9), washer (10), bracket (8), link (2), and screw (11) from post (3). Discard locknut.

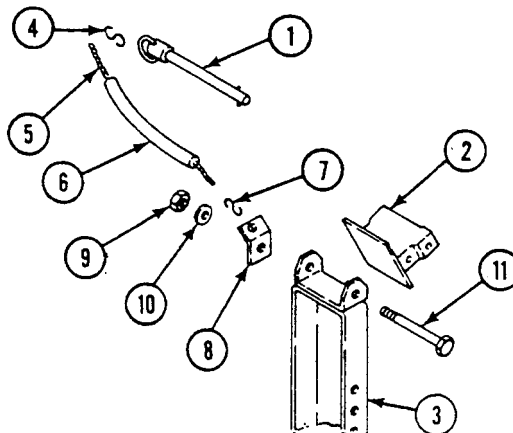

**REPLACE COMMANDER'S SEAT AND POST (M113A3, M1059A3, AND M58 ONLY) —
Continued**

0560 00

INSTALLATION

1. Align link (2) and bracket (8) with post (3). Secure with screw (11), washer (10), and new locknut (9).
2. Install hook (7) in bracket (8) and chain (5). Squeeze both ends of hook to secure.
3. Install tube (6) on chain (5).
4. Install hook (4) on chain (5) and quick-release pin (1). Squeeze both ends of hook to secure.
5. Align link (2) with hull top plate brackets. Secure with pin (1).

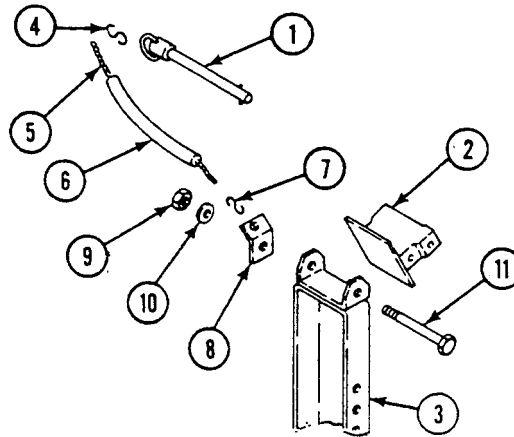

6. Install base (12) in hull crossmember.
7. Align post (3) with base (12). Secure with screw (13), washer (14), and new locknut (15).

NOTE

Do Step 8 for M1059A3 and M58 only.

8. Install screw (16), new lockwasher (17), and nut (18) on post (3).

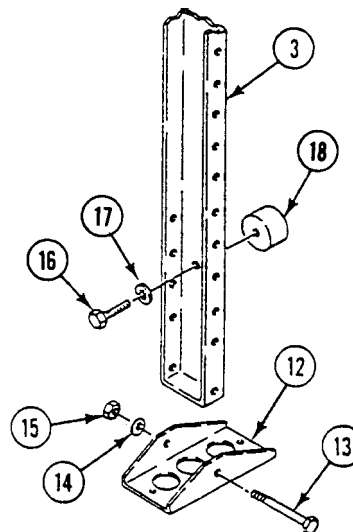

REPLACE COMMANDER'S SEAT AND POST (M113A3, M1059A3, AND M58 ONLY) —
Continued

0560 00

NOTE**Do Step 9 for M113A3 only.**

9. If removed, install commander's jump seat (19) on post assembly (3) (WP 0563 00).
10. Hold seat lock in unlocked position and install seat assembly (20) on post (3).

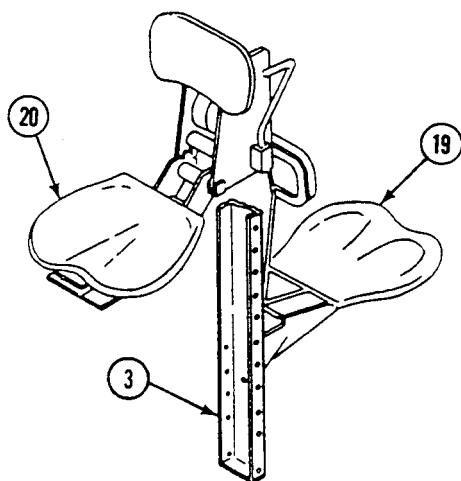
**FOLLOW-THROUGH STEPS**

1. Install commander's platform (WP 0559 00).

END OF TASK

REPLACE COMMANDER'S SEAT AND POST (M1064A3 ONLY)

0561 00

THIS WORK PACKAGE COVERS:

- Removal (page 0561 00-1).
- Installation (page 0561 00-2).

INITIAL SETUP:

Maintenance Level

Unit

Personnel Required

Unit Mechanic

Tools and Special Tools

General Mechanic's Tool Kit (WP 0926 00, Item 65)

References

See your -10

Materials/Parts

- Locknut
- Locknut
- Lockwasher
- Tablock washer (2)

Equipment Condition

- Engine stopped (see your -10)
- Carrier blocked (see your -10)
- Commander's platform removed (WP 0559 00)
- Rifle rack removed (WP 0612 00)

REMOVAL

1. Remove two screws (1) and tablock washers (2) from base of post assembly (3). Discard tablock washers.
2. Remove locknut (4), washer (5), screw (6), and link (7) from hull top plate brackets. Discard locknut.
3. Remove seat and post (3) from carrier.
4. Remove locknut (8), washer (9), link (7), and screw (10) from post (3). Discard locknut.
5. Remove screw (11), lockwasher (12), and nut (13) from post (3). Discard lockwasher.
6. Unlock seat lock. Remove seat assembly (14) from post (3).

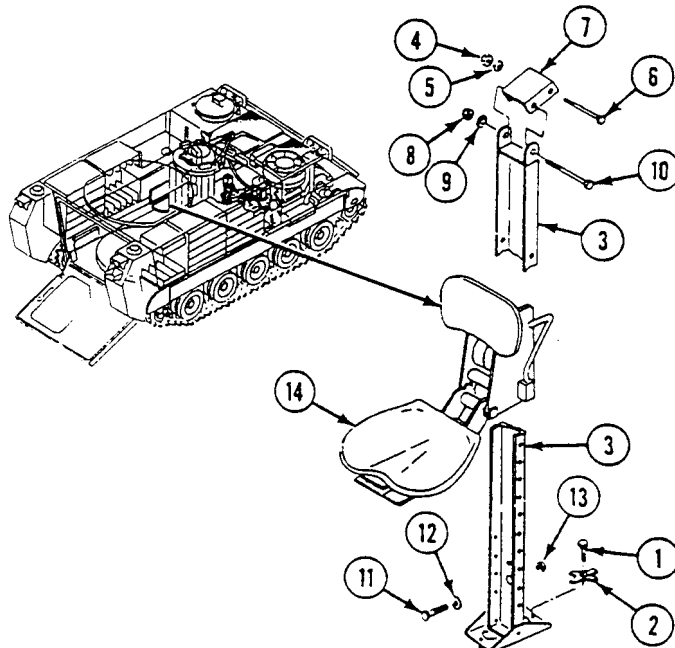

INSTALLATION

1. Hold seat lock in unlocked position. Install seat assembly (14) on post (3).
2. Align nut (13) with post (3). Secure with new lockwasher (12) and screw (11).
3. Align link (7) with post (3). Secure with screw (10), washer (9), and new locknut (8).
4. Place post and seat assembly (14) in carrier. Align link (7) with hull top plate brackets. Secure with screw (6), washer (5), and new locknut (4).
5. Align base of post (3) with hull crossmember. Secure with two new tablock washers (2) and screws (1). Bend tabs on washers to secure screws.

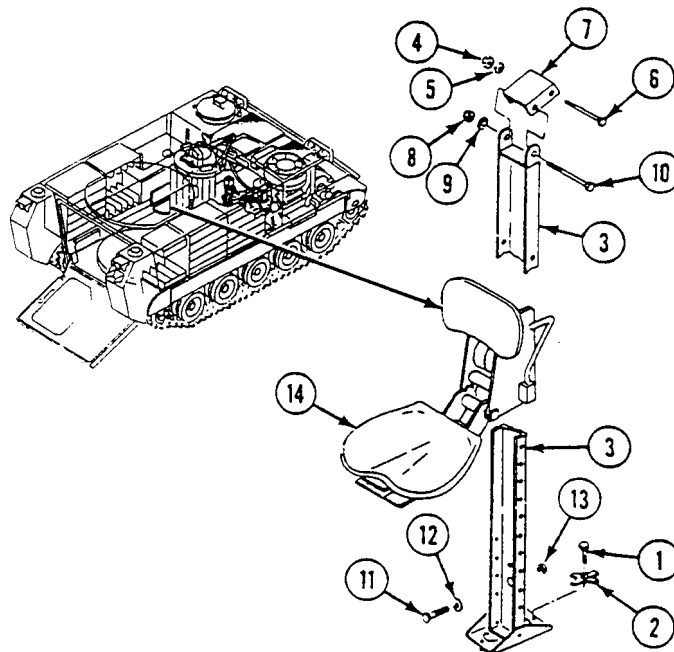
**FOLLOW-THROUGH STEPS**

1. Install rifle rack (WP 0612 00).
2. Install commander's platform (WP 0559 00).

END OF TASK

REPAIR COMMANDER'S SEAT (M113A3, M1059A3, M1064A3, AND M58 ONLY)

0562 00

THIS WORK PACKAGE COVERS:

- Disassembly (page 0562 00-1).
- Cleaning (page 0562 00-4).
- Assembly (page 0562 00-4).

INITIAL SETUP:

Maintenance Level

Unit

Personnel Required

Unit Mechanic

Tools and Special Tools

General Mechanic's Tool Kit (WP 0926 00, Item 65)

Equipment Condition

Materials/Parts

- Cotter pin (4)
- Locknut (6)
- Splined nut, as needed (8)
- Splined washer, as needed (8)
- Spring pin (2)

- Engine stopped (see your -10)
- Carrier blocked (see your -10)
- Ramp lowered (see your -10)
- Commander's seat removed from post (WP 0560 00) or (WP 0561 00)

DISASSEMBLY

1. Remove seat cushion (1).
2. Remove eight screws (2) and washers (3). Remove seat (4) from seat support (5).

NOTE

Remove splined nut(s) only if damaged.

3. If splined nuts (6) need to be replaced, drive old nuts out of seat (4). Discard nuts.

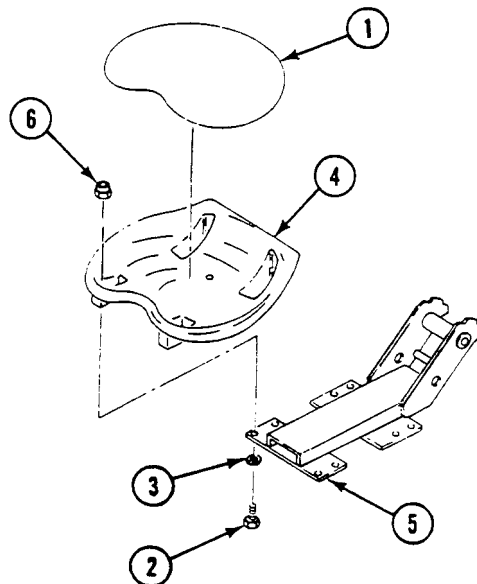

4. Remove two locknuts (7), washers (8), screws (9), and seatbelt (10) from support (5). Discard locknuts.

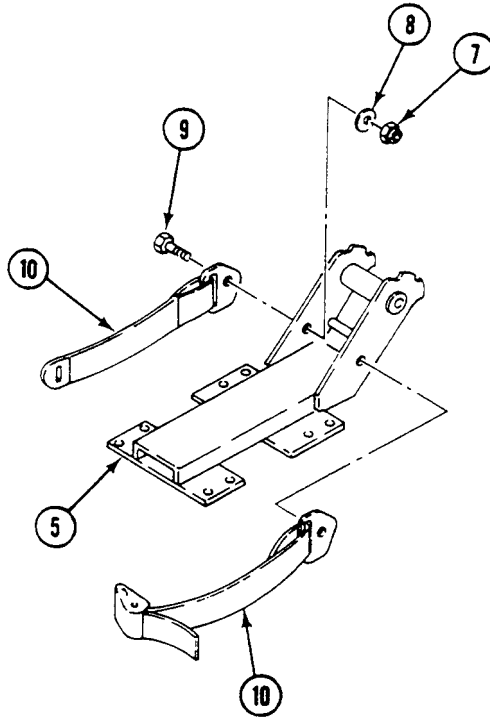

5. Remove spring (1), clip (2), spring pin (3), handle (4), and seat lock (5) from right mount (6). Discard spring pin.
6. Remove two screws (7) and jamnuts (8) from right mount (6).

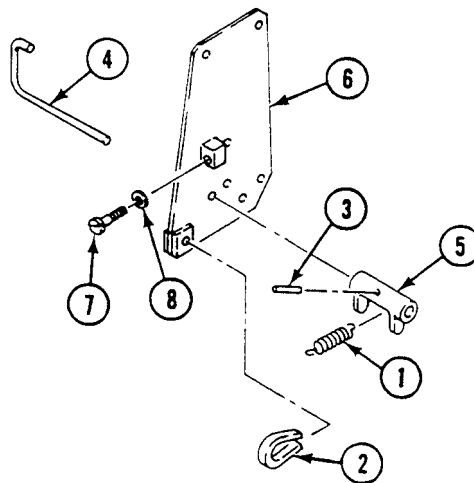

REPAIR COMMANDER'S SEAT (M113A3, M1059A3, M1064A3, AND M58 ONLY) —
Continued

0562 00

7. Remove two cotter pins (9), straight pin (10), handle (11), and spring pin (12) from left mount (13). Discard cotter pins and spring pin.
8. Remove stop pin (14), spring (15), and washer (16) from left mount (13).

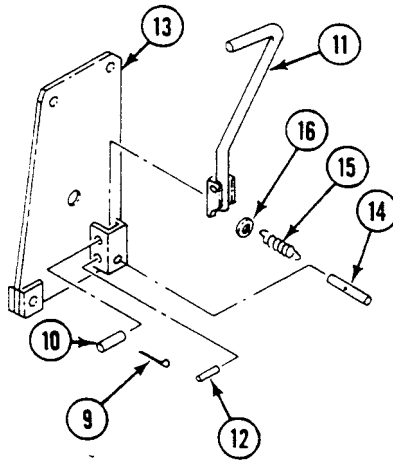

9. Remove two cotter pins (17) and straight pin (18) from left mount (13), support (19), and right mount (6). Discard cotter pins.

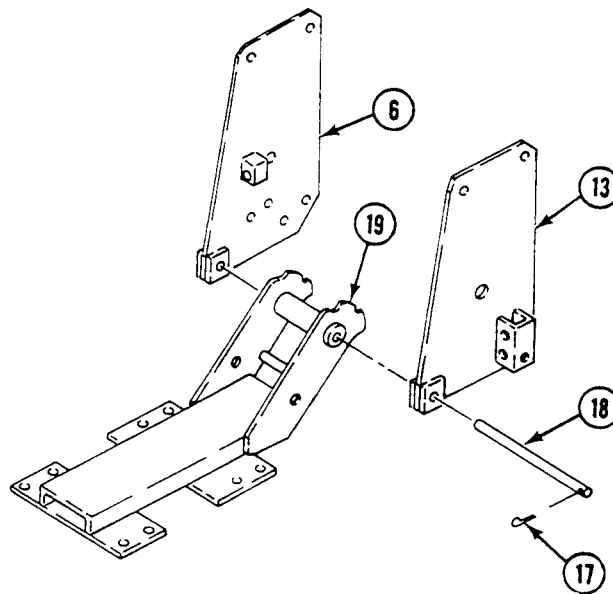

10. Remove locknut (20), washer (21), screw (22), short spacer (23), two long spacers (24), backrest (25), and bracket (26). Discard locknut.
11. Remove locknut (27) and backrest (25) from bracket (26). Discard locknut.

REPAIR COMMANDER'S SEAT (M113A3, M1059A3, M1064A3, AND M58 ONLY) —
Continued

0562 00

- Remove locknut (28), washer (29), screw (30), washer (31), two spacers (32), one spacer (33), and wheel (34). Discard locknut.

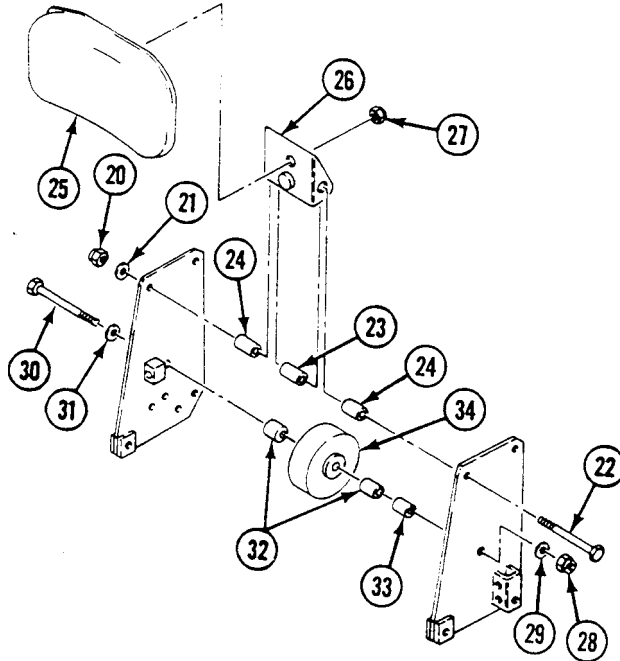

- Remove locknut (1), washer (2), screw (3), two rollers (4), and spacers (5) from left mount (6) and right mount (7). Discard locknut.

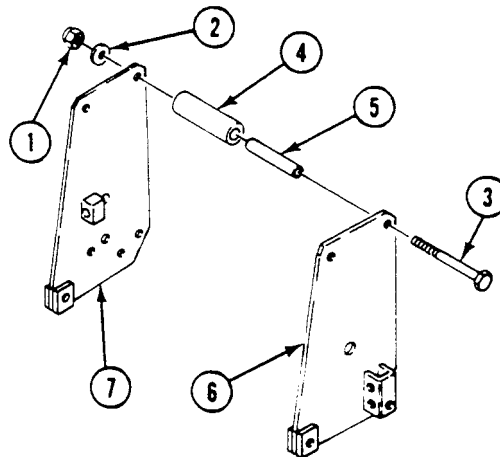

CLEANING

- Clean and inspect parts for damage.
- Replace worn, nicked or deformed parts.

ASSEMBLY

- Install screw (3) in left mount (6). Assemble two spacers (5) and rollers (4) on screw.

2. Install screw (3) through right mount (7). Secure with washer (2) and new locknut (1).

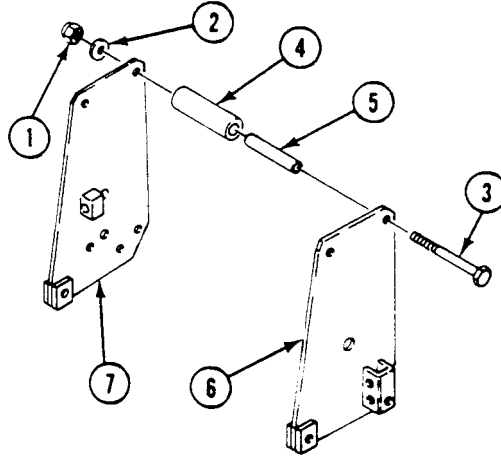

3. Install screw (8) and washer (9) in right mount (7). Assemble two spacers (10), one spacer (11), and wheel (12) on screw (8).
4. Install screw (8) through left mount (6). Secure with washer (13) and new locknut (14).
5. Install screw (15) in left mount (6). Assemble two long spacers (16), one short spacer (17), and bracket (18) on screw (15).
6. Install screw (15) in right mount (7). Secure with washer (19) and new locknut (20).
7. Secure backrest (21) to bracket (18) with new locknut (22).

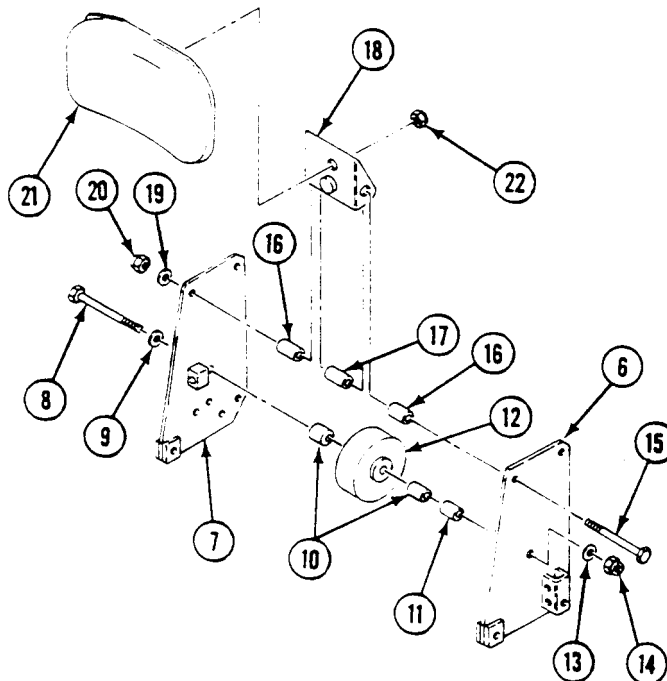

REPAIR COMMANDER'S SEAT (M113A3, M1059A3, M1064A3, AND M58 ONLY) —
Continued

0562 00

8. Install straight pin (23) through left mount (6), seat support (24), and right mount (7). Secure with two new cotter pins (25).

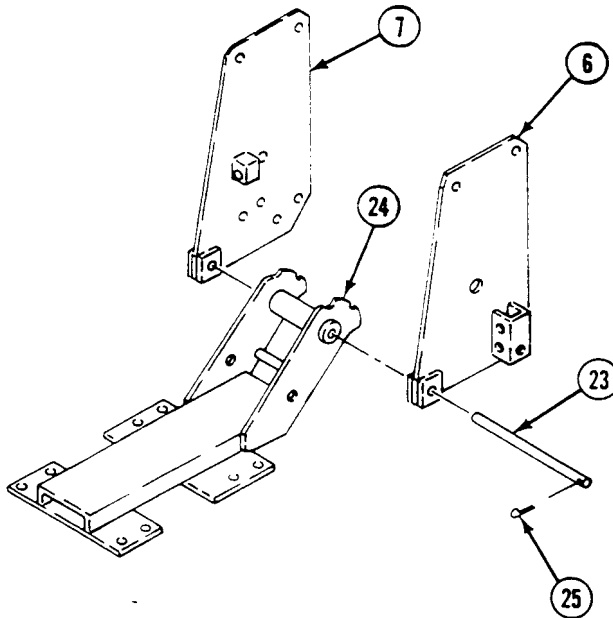

9. Install seat lock (1) on right mount (2). Secure with handle (3), new spring pin (4), clip (5), and spring (6).
10. Install two screws (7) and jamnuts (8) on right mount (2).

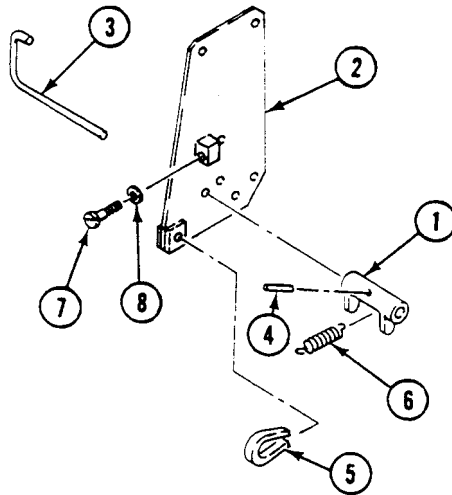

11. Install washer (9), spring (10), and stop pin (11) in left mount (12).
12. Install new spring pin (13), handle (14), and straight pin (15) in left mount (12).

REPAIR COMMANDER'S SEAT (M113A3, M1059A3, M1064A3, AND M58 ONLY) —
Continued

0562 00

13. Install two new cotter pins (16) through straight pin (15).

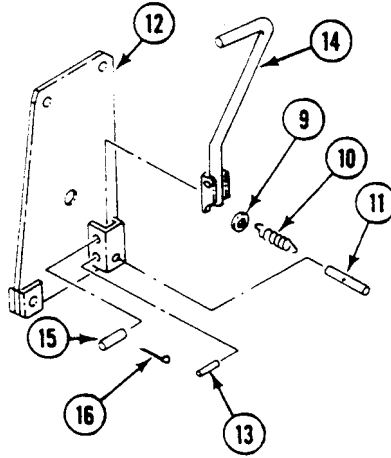

14. Install seatbelt (17) on support (18). Secure with two screws (19), washers (20), and new locknuts (21).
15. If removed, install new splined nuts (22) in seat (23).
16. Install seat (23) on support (18). Secure with eight screws (24) and washers (25).

REPAIR COMMANDER'S SEAT (M113A3, M1059A3, M1064A3, AND M58 ONLY) —
Continued

0562 00

17. Install seat cushion (26) on seat (23).

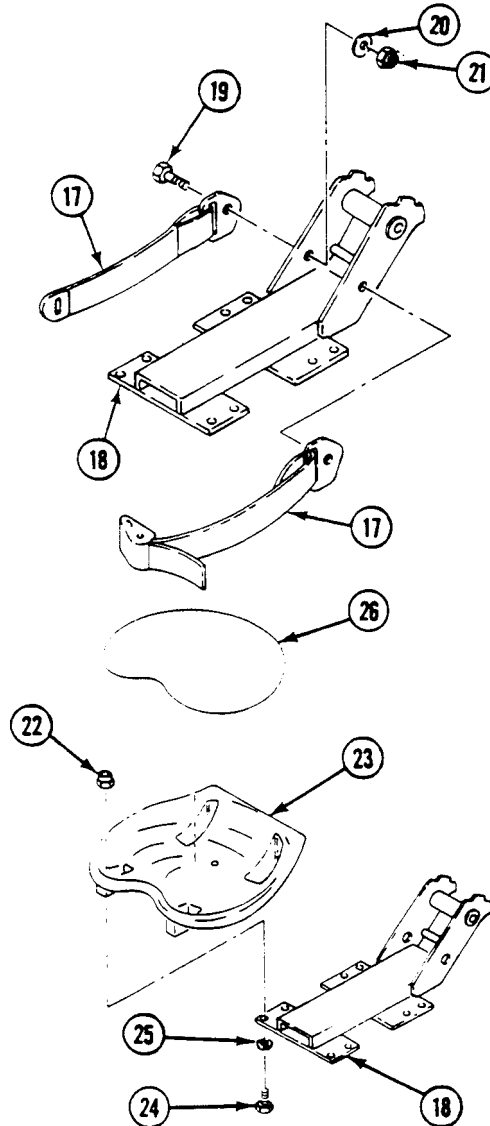
**FOLLOW-THROUGH STEPS**

1. Install commander's seat on post (WP 0560 00) or (WP 0561 00).
2. Start engine (see your -10).
3. Raise and lock ramp (see your -10).
4. Stop engine (see your -10).

END OF TASK

REPLACE COMMANDER'S JUMP SEAT (M113A3 ONLY)

0563 00

THIS WORK PACKAGE COVERS:

Removal (page 0563 00-1).
 Installation (page 0563 00-1).

INITIAL SETUP:

Maintenance Level

Unit

Personnel Required

Unit Mechanic

Tools and Special Tools

General Mechanic's Tool Kit (WP 0926 00, Item 65)

References

See your -10

Materials/Parts

Large cotter pin
 Locknut (2)
 Small cotter pin (4)
 Splined nut, as needed (8)

Equipment Condition

Engine stopped (see your -10)
 Carrier blocked (see your -10)
 Ramp lowered (see your -10)

REMOVAL

1. Remove cushion (1) from seat (2).
2. Remove two locknuts (3), washers (4), screws (5), and seatbelt (6) from seat support (7). Discard locknuts.
3. Remove eight screws (8), washers (9), and seat (2) from support (7).

NOTE

Remove splined nut(s) only if damaged.

4. If splined nut(s) (10) need to be replaced, drive old splined nuts out of seat (2). Discard nuts.

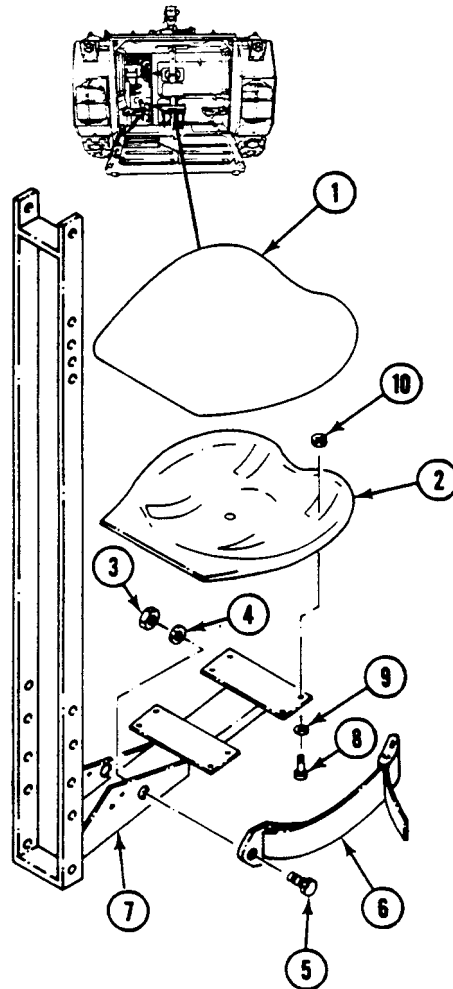

5. Remove spring (1) from support (2) and large cotter pin (3).
6. Remove cotter pin (3) from post (4). Discard cotter pin.
7. Remove two cotter pins (5) from pin (6). Remove pin from support (2). Discard cotter pins.
8. Remove two cotter pins (7) from pin (8). Remove pin (8), two washers (9), and support (2) from bracket (10). Discard cotter pins.
9. Remove two nuts (11), screws (12), backrest support (13), and bracket (10) from post (4).

10. Remove nut (14) and backrest (15) from support (13).

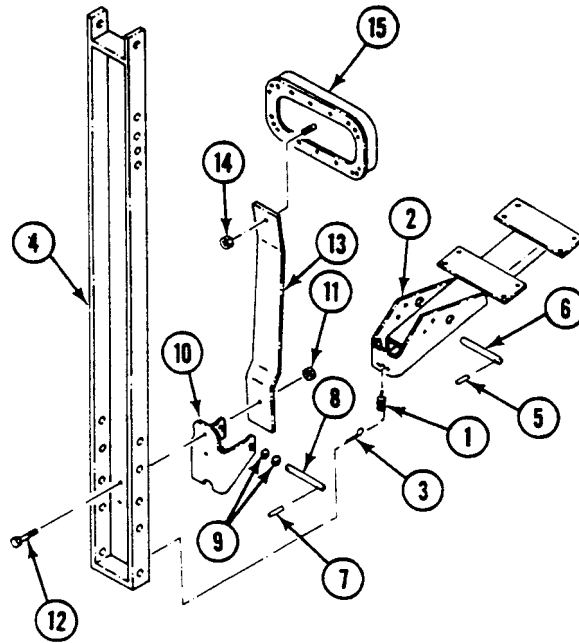

INSTALLATION

1. Install backrest (15) on backrest support (13). Secure with nut (14).
2. Align support (13) and bracket (10) with post (4). Secure with two screws (12) and nuts (11).
3. Align seat support (2) with bracket (10). Secure with pin (8), two washers (9), and new small cotter pins (7).
4. Install pin (6) in support (2). Secure with two new small cotter pins (5).
5. Install new large cotter pin (3) in post (4).

6. Install spring (1) on large cotter pin (3) and support (2).

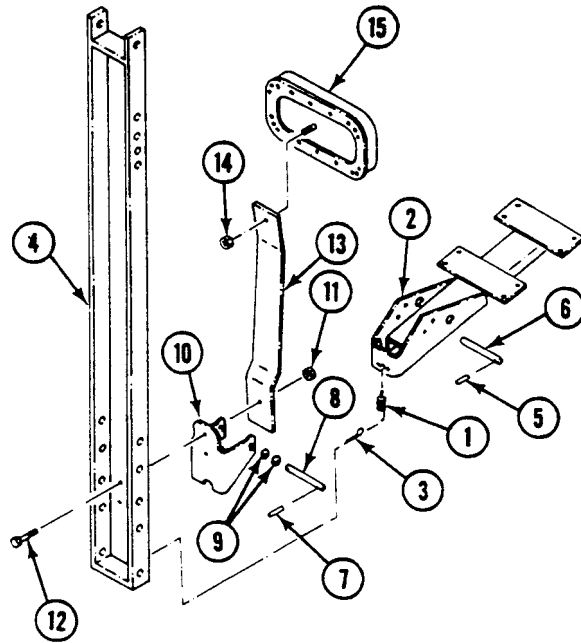

7. If removed, install new splined nuts (16) in seat (17).
8. Align seat (17) with support (2). Secure with eight washers (18) and screws (19).
9. Align seatbelt (20) with support (2). Secure with two screws (21), washers (22), and new locknuts (23).
10. Install cushion (24) on seat (17).

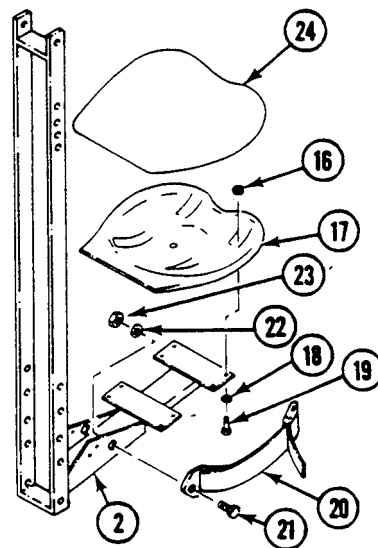

FOLLOW-THROUGH STEPS

1. Start engine (see your -10).
2. Raise and lock ramp (see your -10).
3. Stop engine (see your -10).

END OF TASK

REPLACE/REPAIR COMMANDER'S PLATFORM AND POST (M577A3 AND M1068A3 ONLY)

0564 00

THIS WORK PACKAGE COVERS:

- Removal (page 0564 00-1).
- Disassembly (page 0564 00-2).
- Inspection (page 0564 00-3).
- Assembly (page 0564 00-3).
- Installation (page 0564 00-4).

INITIAL SETUP:

Maintenance Level

Unit

Personnel Required

Unit Mechanic

Tools and Special Tools

General Mechanic's Tool Kit (WP 0926 00, Item 65)

References

See your -10

Materials/Parts

- Cotter pin (2)
- Locknut (3)
- Locknut (2)
- Locknut (10)
- Spring pin

Equipment Condition

- Engine stopped (see your -10)
 - Carrier blocked (see your -10)
 - Ramp lowered (see your -10)
-

REMOVAL

1. Remove two screws (1) and washers (2) from base (3).
2. Open both ends of hook (4). Remove from hull top plate lug and chain (5).
3. Remove tube (6) from chain (5).
4. Open both ends of hook (7). Remove hook (7) from chain (5) and quick-release pin (8).
5. Remove locknut (9), washer (10), screw (11), and link (12) from hull top plate brackets. Remove post (13) and platform (14) from carrier. Discard locknuts.
6. Remove pin (8) and link (12) from post (13).
7. Remove two locknuts (15), washers (16), screws (17), and base (3) from post (13). Discard locknuts.

REPLACE/REPAIR COMMANDER'S PLATFORM AND POST (M577A3 AND M1068A3 ONLY) — Continued

0564 00

8. Unlock platform lock and remove platform (14) from post (13).

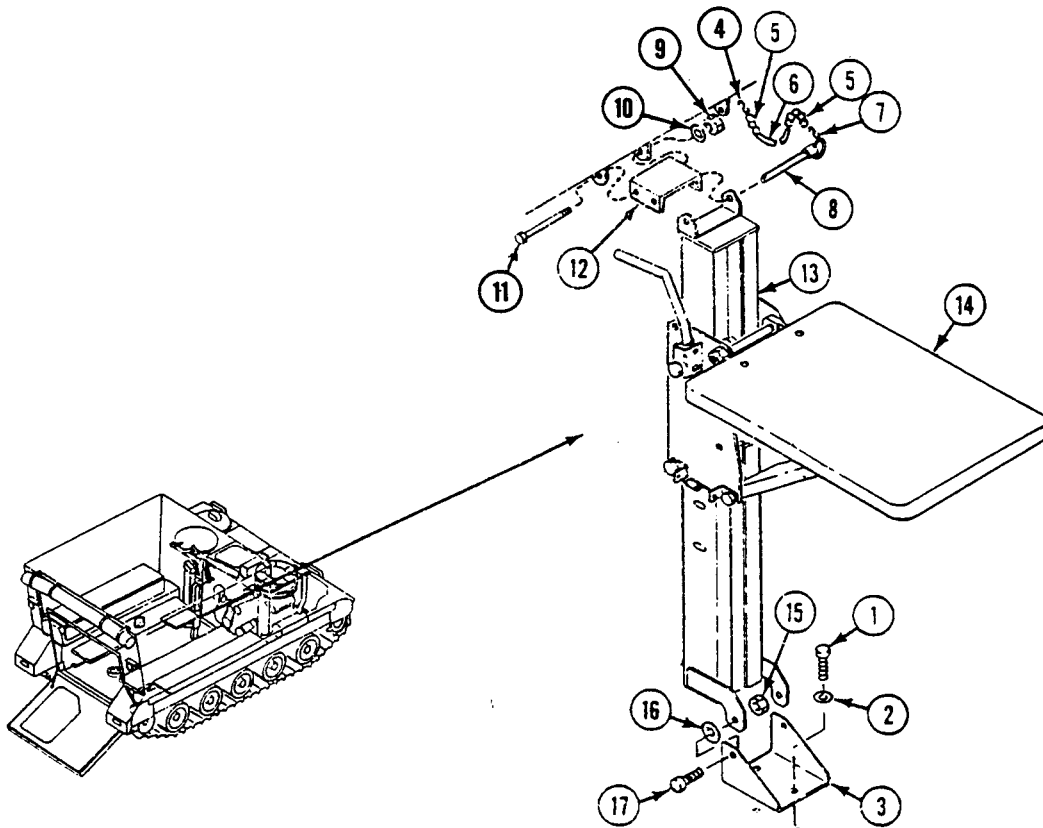

DISASSEMBLY

1. Remove two cotter pins (1) from straight pin (2). Discard cotter pins.
2. Remove straight pin (2) and handle (3) from left mount (4).
3. Remove spring pin (5), stop pin (6), washer (7), and spring (8) from left mount (4). Discard spring pin.
4. Remove two locknuts (9), four washers (10), and rod (11) from platform (12). Discard locknuts.
5. Remove two locknuts (13), four washers (14), rod (15), and platform (12) from left mount (4), and right mount (16). Discard locknuts.
6. Remove locknut (17), washer (18), screw (19), catch (20), and spring (21) from platform (12). Discard locknut.
7. Remove two locknuts (22), screws (23), four washers (24), and two bumpers (25) from platform (12). Discard locknuts.
8. Remove locknut (26), screw (27), spring (28), and catch (29) from brace (30). Discard locknut.
9. Remove four locknuts (31), two screws (32), two screws (33), lugs (34), and spring (35) from left mount (4). Discard locknuts.

REPLACE/REPAIR COMMANDER'S PLATFORM AND POST (M577A3 AND M1068A3 ONLY) — Continued

0564 00

10. Remove three rollers (36) and spacers (37) from between left mount (4) and right mount (16).

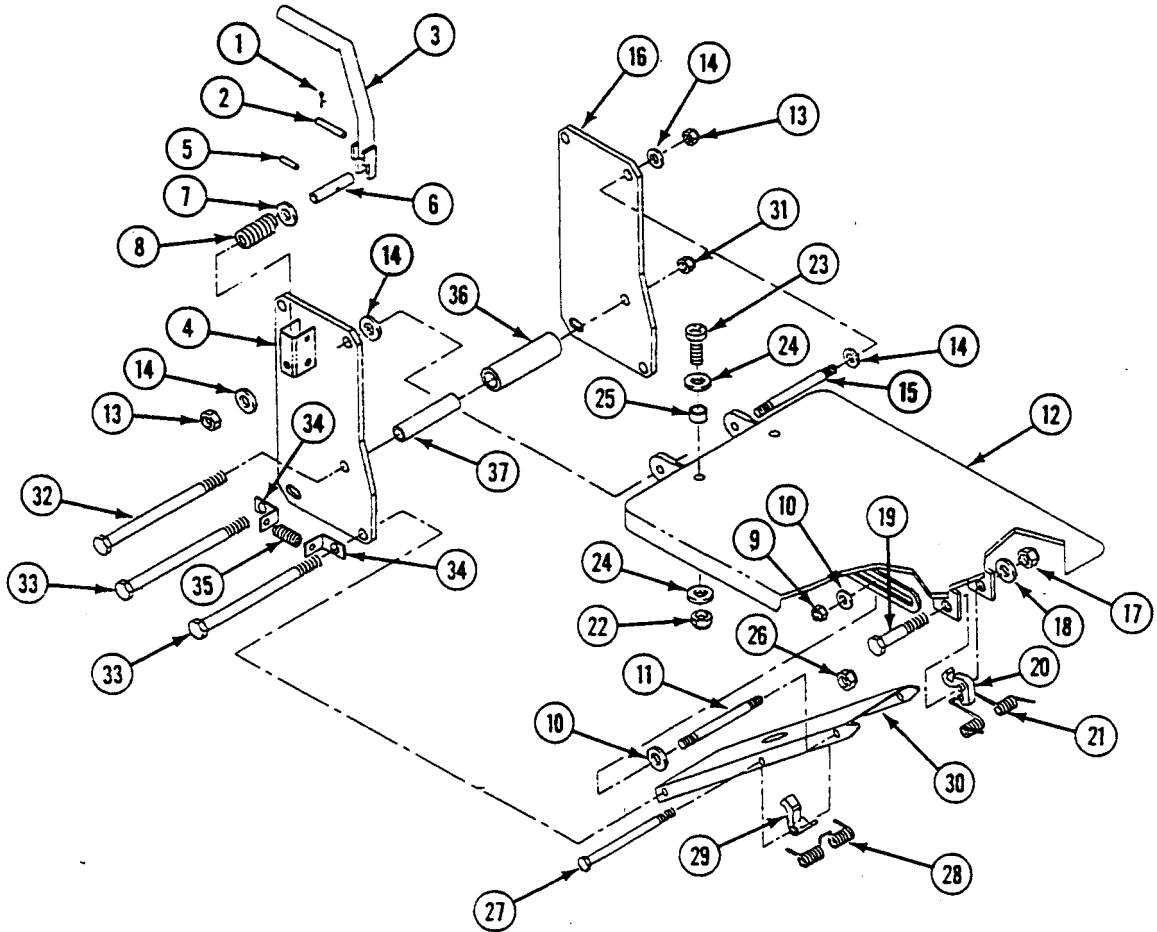

INSPECTION-ACCEPTANCE AND REJECTION CRITERIA

1. Inspect parts for corrosion, distortion, cracks, breaks, and loose or missing parts.

ASSEMBLY

1. Install three spacers (1) and rollers (2) between left mount (3) and right mount (4).
2. Install two lugs (5) on left mount (3).
3. Install two screws (6) and two screws (7) through left mount (3), three spacers (1) rollers (2) two lugs (5), and right mount (4). Install spring (9) on lugs (5).
4. Install screw (10), spring (11), and catch (12) on brace (13). Secure with new locknut (14).
5. Install two bumpers, (15), four washers (16), two screws (17), and new locknuts (18) on platform (19).
6. Install spring (20), catch (21), screw (22), washer (23), and nut (24) on platform (19).
7. Install platform (19) between left mount (3) and right mount (4). Secure with rod (25), four washers (26), and two new locknuts (27).

REPLACE/REPAIR COMMANDER'S PLATFORM AND POST (M577A3 AND M1068A3 ONLY) — Continued

0564 00

8. Install rod (28) through platform (19) and brace (13). Secure with four washers (29) and two new locknuts (30).
9. Install spring (31), washer (32), stop pin (33), new spring pin (34), and handle (35) on left mount (3).
10. Secure handle (35) with straight pin (36) and two new cotter pins (37).

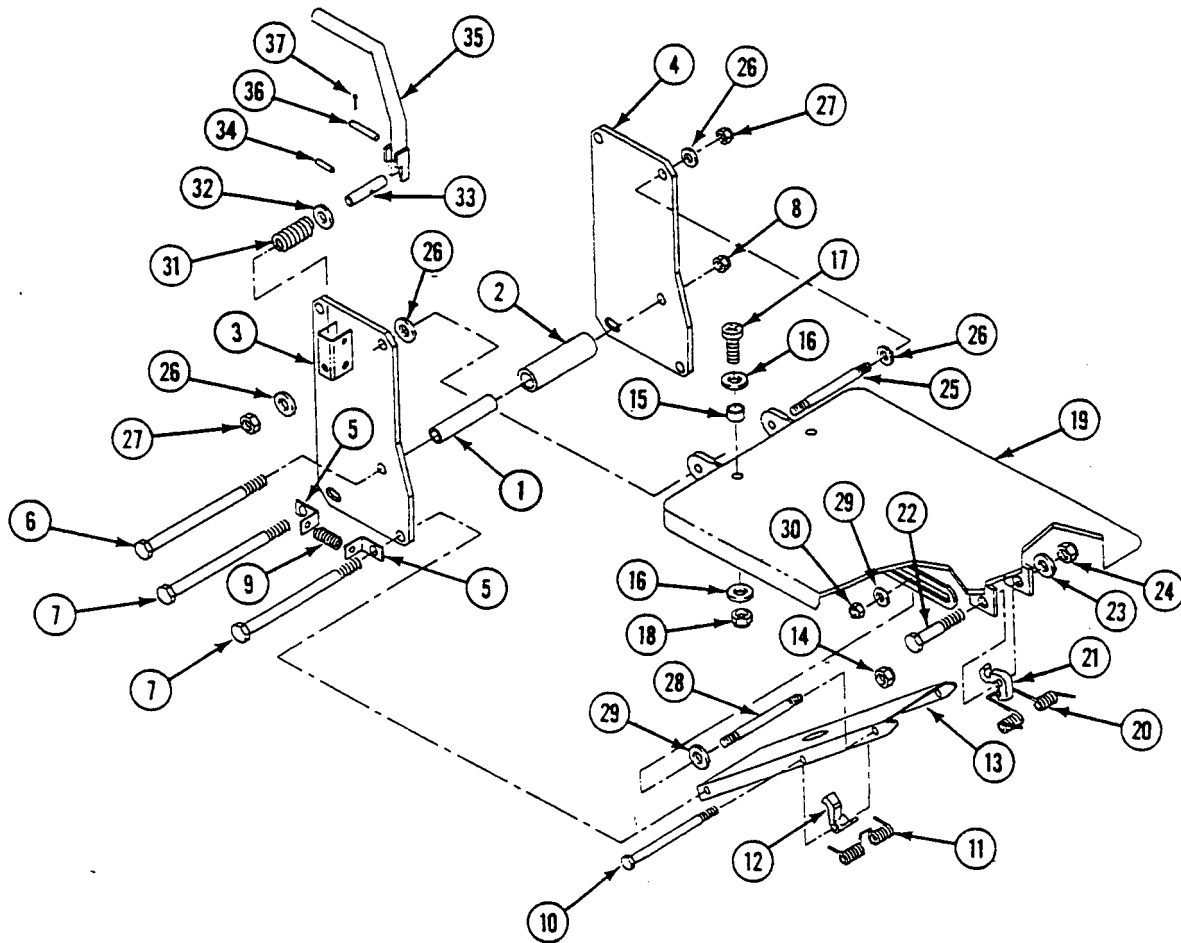

INSTALLATION

1. Hold platform lock in unlocked position and install platform (1) on post (2).
2. Align base (3) with post (2). Secure with two screws (4), washers (5), and new locknuts (6).
3. Install hook (7) on quick-release pin (8) and chain (9). Squeeze both ends of hook to secure.
4. Install tube (10) on chain (9).
5. Install hook (11) on chain (9) and hull top lug plate. Squeeze both ends of hook to secure.
6. Align link (12) with hull top plate brackets. Secure with screw (13), washer (14), and new locknut (15).
7. Place post (2) and platform (1) in carrier. Align post with link (12). Secure with quick-release pin (8).

REPLACE/REPAIR COMMANDER'S PLATFORM AND POST (M577A3 AND M1068A3 ONLY) — Continued

0564 00

8. Align base (3) with hull crossmember. Secure with two washers (16) and screws (17).

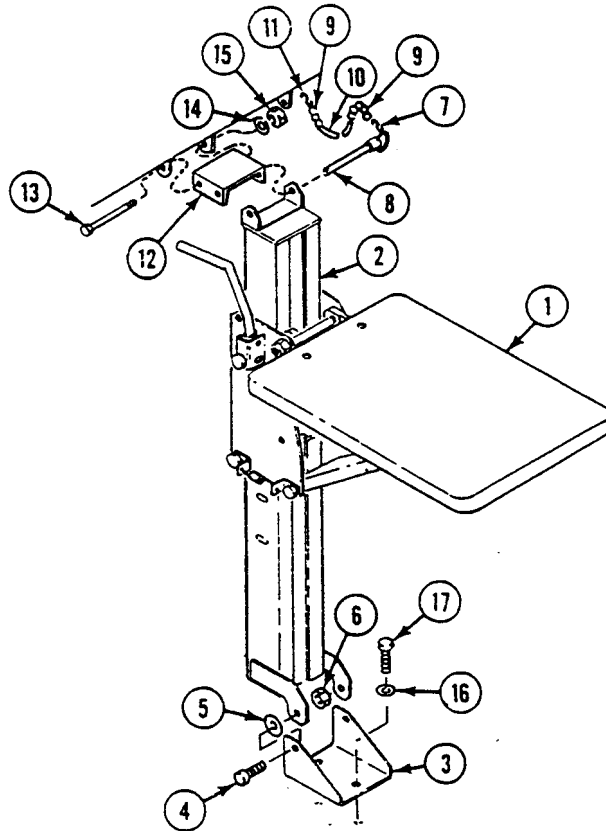
**FOLLOW-THROUGH STEPS**

1. Start engine (see your -10).
2. Raise and lock ramp (see your -10).
3. Stop engine (see your -10).

END OF TASK

REPLACE/REPAIR COMMANDER'S SEAT (M1068A3 ONLY)

0566 00

THIS WORK PACKAGE COVERS:

- Removal (page 0566 00-1).
- Disassembly (page 0566 00-2).
- Assembly (page 0566 00-3).
- Installation (page 0566 00-6).

INITIAL SETUP:

Maintenance Level

Unit

Personnel Required

Unit Mechanic

Tools and Special Tools

General Mechanic's Tool Kit (WP 0926 00, Item 65)

References

See your -10

Materials/Parts

- Cotter pin (2)
- Locknut (2)

Equipment Condition

- Engine stopped (see your -10)
- Carrier blocked (see your -10)
- Ramp lowered (see your -10)

REMOVAL

1. Remove four pins (1) securing commander's seat (2) to track bracket.
2. Remove commander's seat (2) from carrier.

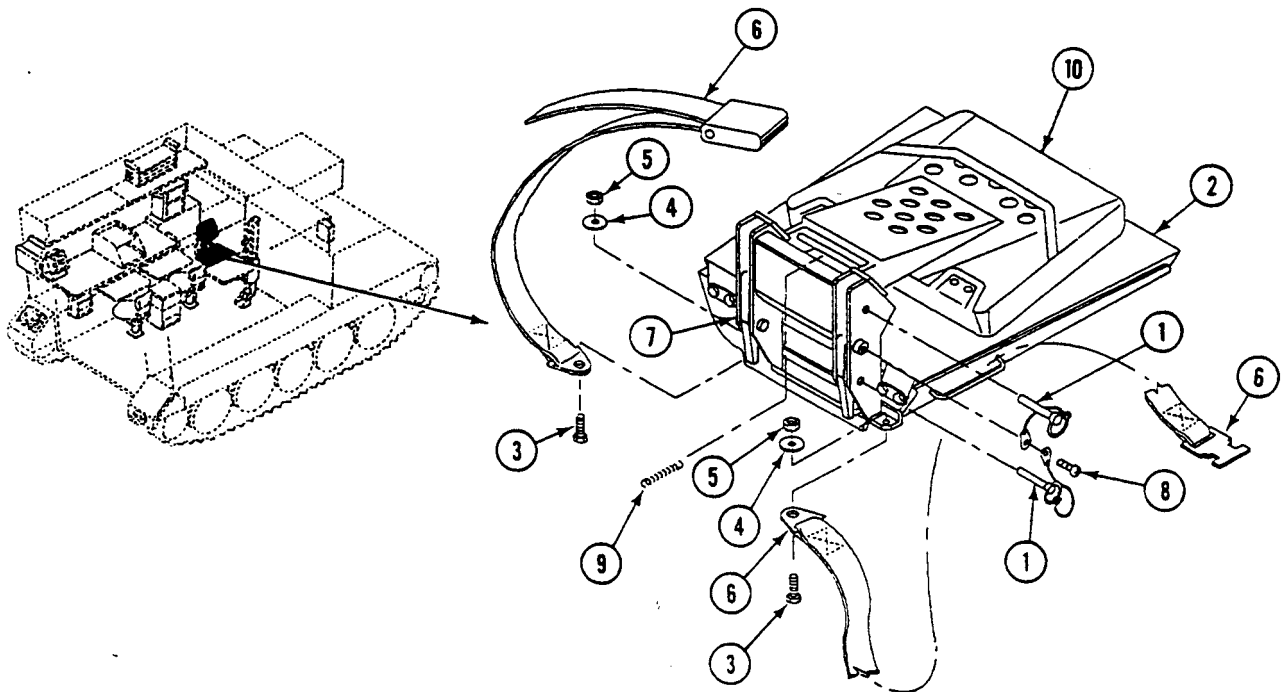

DISASSEMBLY

1. Remove two screws (3), washers (4), locknuts (5), and belts (6) from seat bracket (7). Discard locknuts.
2. Remove two screws (8) and four pins (1) from seat bracket (7).
3. Remove two springs (9) from seat back (10) and seat bracket (7).

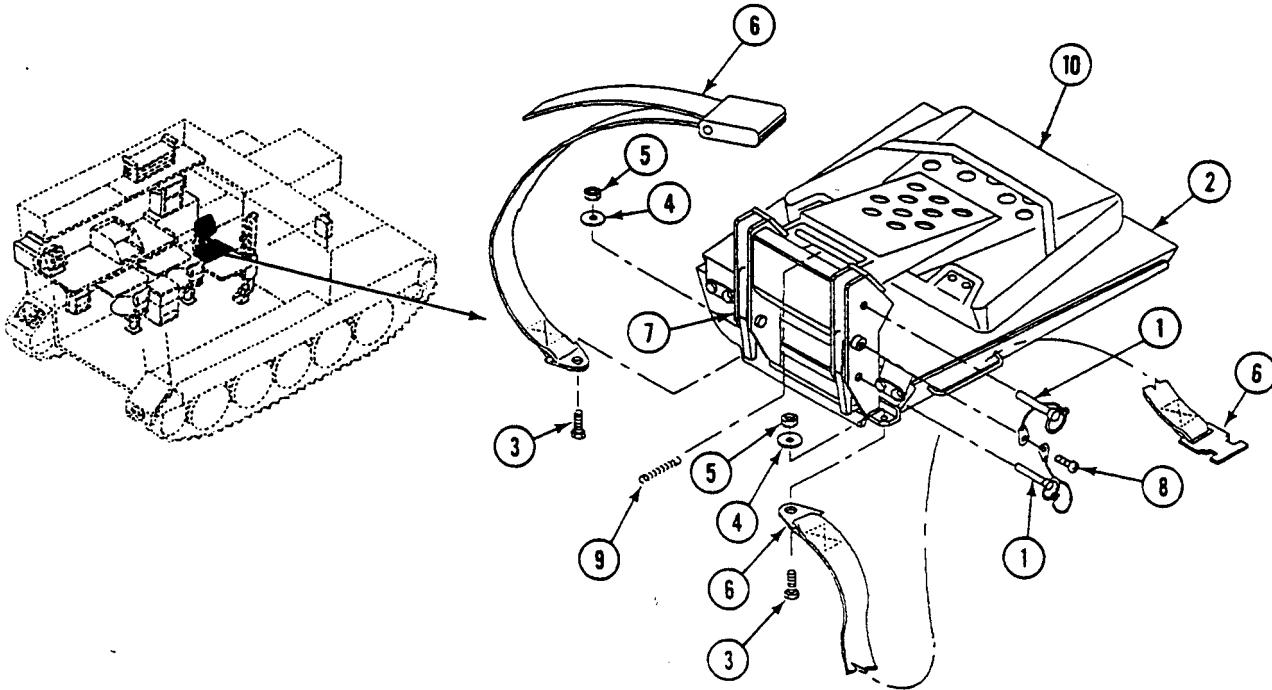

4. Remove two cotter pins (1), pins (2), seat bottom (3), and seat back (4) from seat bracket (5). Discard cotter pins.
5. Remove four screws (6), two retainers (7), and back cushion (8) from seat back (4).
6. Remove ring (9), pin (10), and spring (11) from seat bracket (5).
7. Remove four screws (12) and two retainers (13) from cushion (14) and seat bottom (3).

8. Remove two screws (15), retainer (16), and cushion (14) from seat bottom (3).

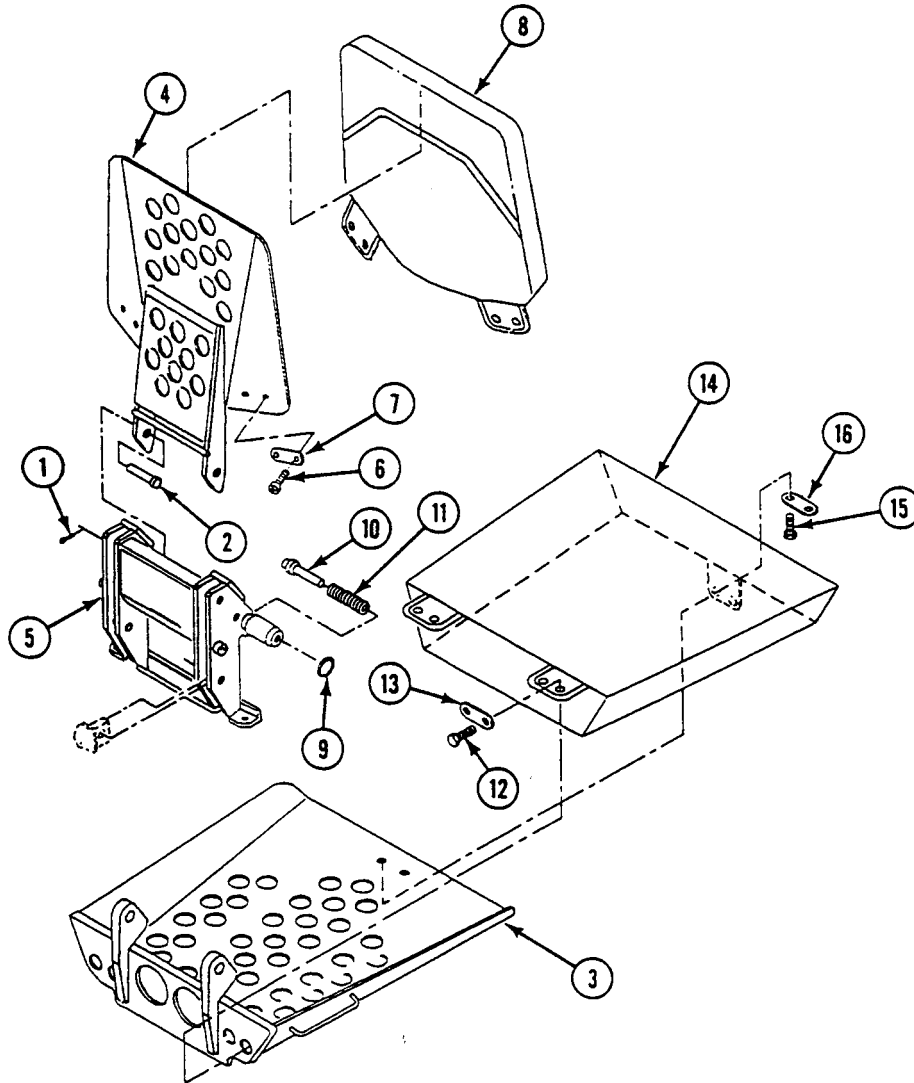

ASSEMBLY

1. Position cushion (14) on seat bottom (3). Secure with retainer (16), two screws (15), two retainers (13), and four screws (12).
2. Position cushion (8) on seat back (4). Secure with two retainers (7), and four screws (6).
3. Position seat bracket (5) on seat bottom (3), and seat back (4) on seat bracket (5). Secure with two pins (2) and new cotter pins (1).

4. Install spring (11), pin (10), and ring (9) in seat bracket (5).

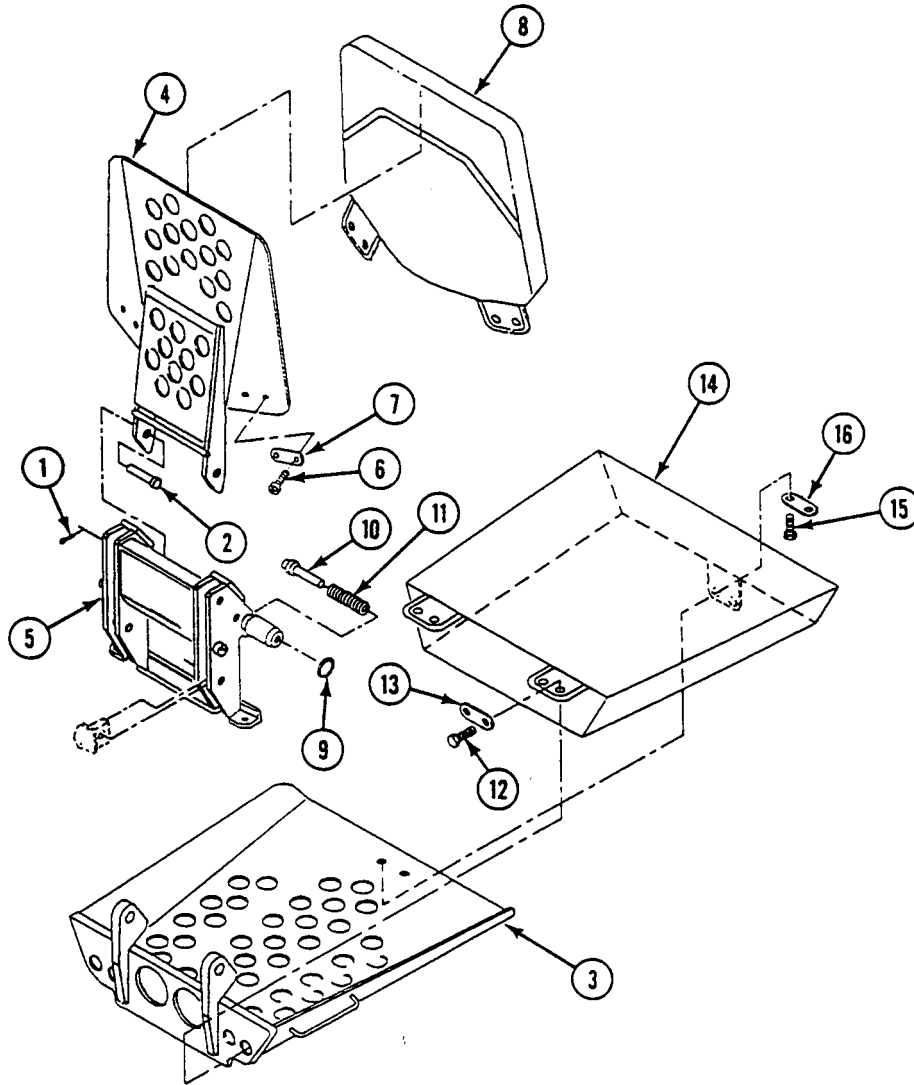

5. Install two springs (1) on seat back (2) and seat bracket (3).
6. Install four pins (4) and two screws (5) on seat bracket (3).
7. Install two seat belts (6) as follows:

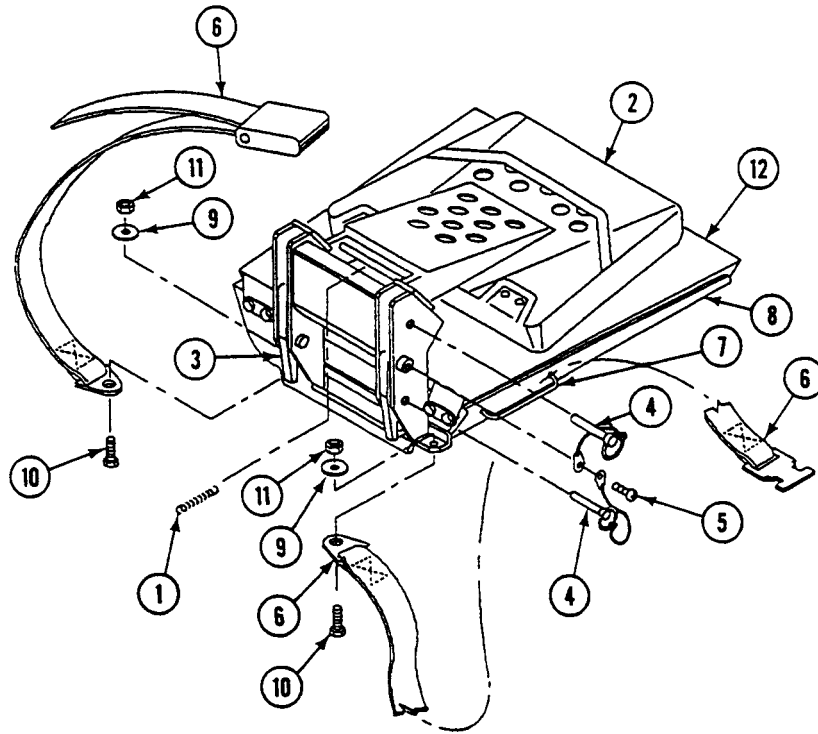

- a. Position two seat belts (6) through loops (7) on seat bottom (8).
- b. Secure two seat belts (6) to seat bracket (3) with two washers (9), screws (10), and new locknuts (11).

INSTALLATION

1. Position commander's seat (12) on track bracket. Secure four pins (4).

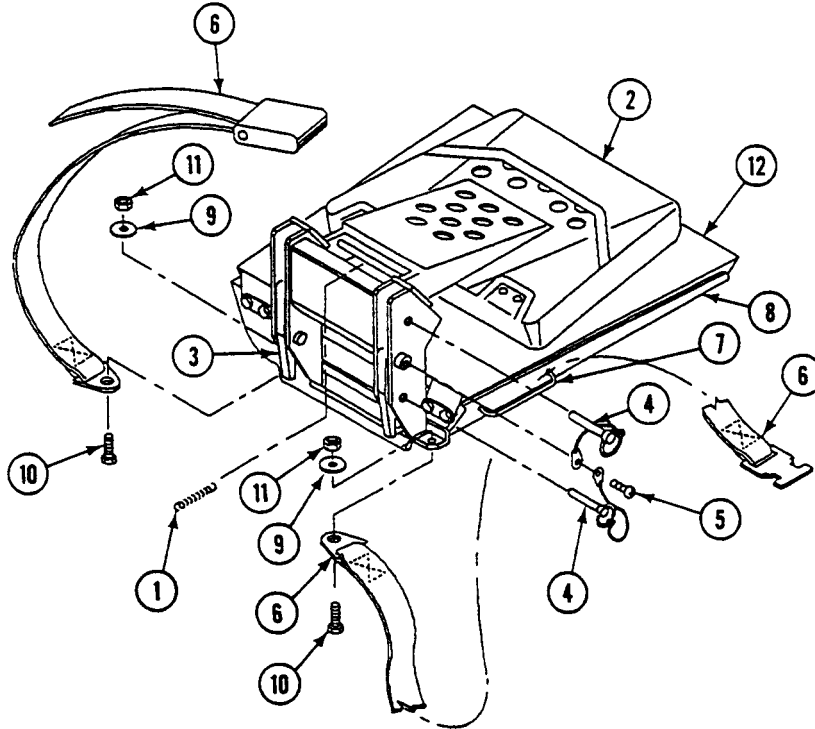
**FOLLOW-THROUGH STEPS**

1. Start engine (see your -10).
2. Raise and lock ramp (see your -10).
3. Stop engine (see your -10).

END OF TASK

REPLACE/REPAIR OPERATOR'S SEAT (M1059A3 ONLY)

0567 00

THIS WORK PACKAGE COVERS:

- Removal (page 0567 00-1).
- Disassembly (page 0567 00-2).
- Assembly (page 0567 00-3).
- Installation (page 0567 00-4).

INITIAL SETUP:

Maintenance Level

Unit

Personnel Required

Unit Mechanic

Tools and Special Tools

- General Mechanic's Tool Kit (WP 0926 00, Item 65)
- Socket Wrench Set (WP 0926 00, Item 72)
- Torque Wrench (WP 0926 00, Item 81)

References

See your -10

Materials/Parts

- Cotter pin (4)
- Locknut (2)
- Lockwasher (2)

Equipment Condition

- Engine stopped (see your -10)
 - Carrier blocked (see your -10)
-

REMOVAL

1. Remove four quick release pins (1) from seat bracket (2) and sponson bracket (3).
2. Remove two screws (4), lockwashers (5), and bracket (6) from box beam. Discard lockwashers.
3. Remove screw (7), washer (8), locknut (9), and seat belt (10) from bracket (6). Discard locknut.
4. Remove screw (11), washer (12), locknut (13), and seat belt (14) from bracket (2).
5. Remove four screws (15) and two retainers (16) from cushion (17) and pan (18).
6. Remove two screws (19), retainer (20), and cushion (17) from pan (18).

7. Remove four screws (21), two retainers (22), and cushion (23) from seat back (24).

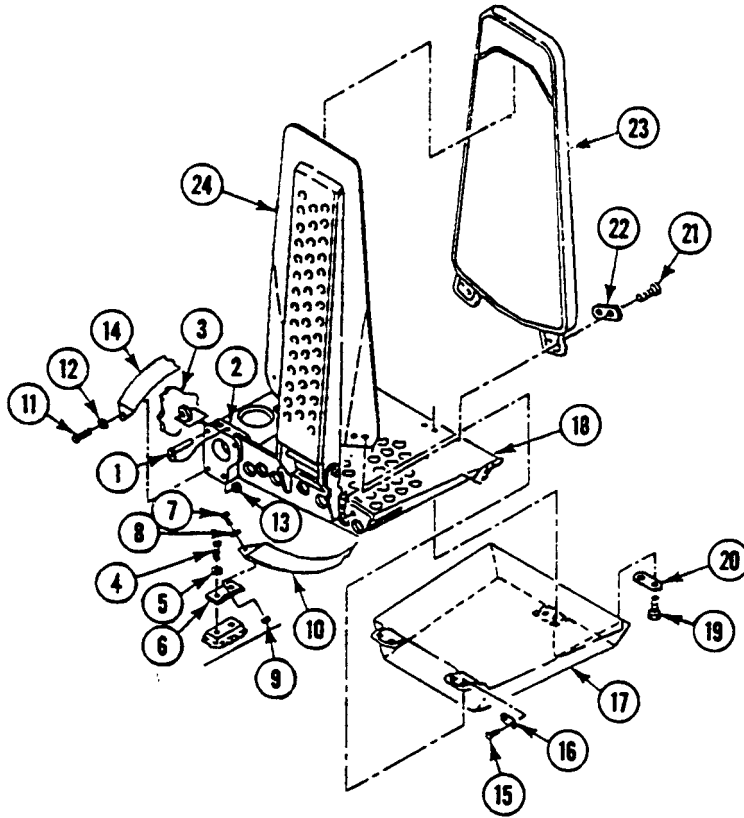

DISASSEMBLY

1. Remove two cotter pins (1) and headed pins (2) from seat pan (3) and seat back (4). Discard cotter pins.
2. Remove two springs (5) and pins (6) from seat back (4) and seat pan (3).
3. Remove two cotter pins (7) and headed pins (8) from seat pan (3) and seat bracket (9). Discard cotter pins.
4. Remove two springs (10) from seat bracket (9) and seat pan (3).

5. Remove two screws (11) and four lanyards (12), with quick release pins attached, from seat bracket.

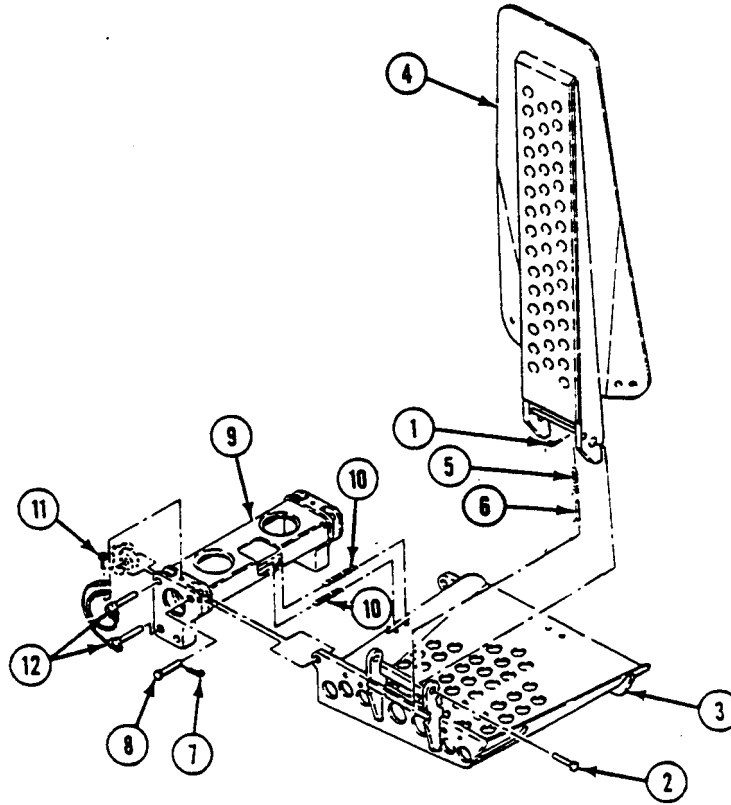

ASSEMBLY

1. Install four lanyards (12), with quick release pins attached, on seat bracket (9) with two screws (11).
2. Install seat bracket (9) on seat pan (3). Secure with two headed pins (8) and new cotter pins (7).
3. Tilt seat bracket (9) and install two springs (10) on seat bracket and seat pan (3).
4. Install seat back (4) on seat pan (3). Secure with two headed pins (2) and new cotter pins (1).

5. Tilt seat back (4) and install two springs (5) and pins (6) on seat back and seat pan (3).

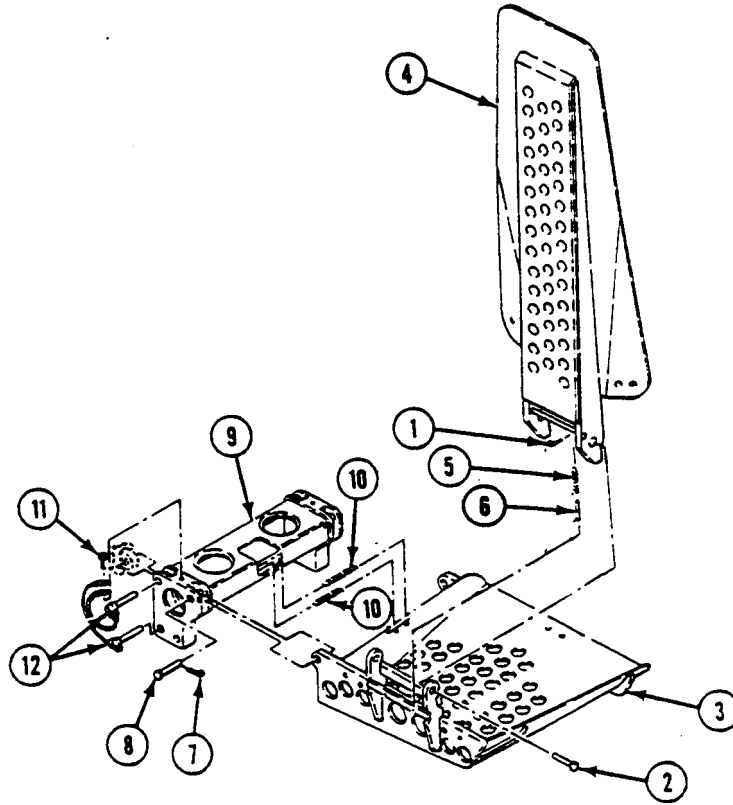

INSTALLATION

1. Install cushion (1) and two retainers (2) on seat back (3). Secure with four screws (4).
2. Install cushion (5) and two retainers (6) on pan (7). Secure with four screws (8).
3. Install retainer (9) and two screws (10) on pan (7) and cushion (5).
4. Install seat belt (11) on bracket (12). Secure with screw (13), washer (14), and new locknut (15). **TIGHTEN LOCKNUT TO 264-288 LB-IN (30-32 N·m) TORQUE.**
5. Install bracket (12) on box beam. Secure with two screws (16) and washers (17). **TIGHTEN SCREWS TO 264-288 LB-IN (30-32 N·m) TORQUE.**
6. Install seat belt (18) on bracket (19). Secure with screw (20), washer (21), and new locknut (22). **TIGHTEN LOCKNUT TO 264-288 LB-IN (30-32 N·m) TORQUE.**

7. Install four quick release pins (23) on seat bracket (19) and sponson bracket (24).

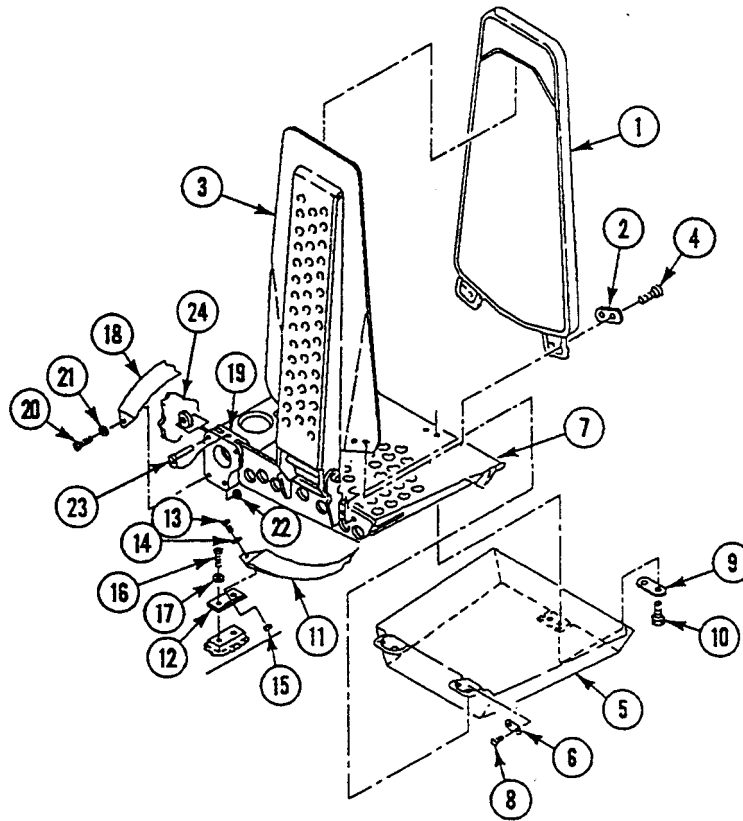

END OF TASK

REPLACE/REPAIR RADIO OPERATOR'S SEAT (M1068A3 AND M58 ONLY)

0568 00 ■

THIS WORK PACKAGE COVERS:

- Removal (page 0568 00-1).
- Disassembly (page 0568 00-2).
- Assembly (page 0568 00-4).
- Installation (page 0568 00-6).

INITIAL SETUP:

Maintenance Level

Unit

Locknut (6)

Locknut (6)

Locknut

Tools and Special Tools

General Mechanic's Tool Kit (WP 0926 00, Item 65)

Drill Set (WP 0926 00, Item 18)

Portable Electric Drill (WP 0926 00, Item 20)

Torque Wrench (WP 0926 00, Item 83)

Lockwasher (2)

Short spring pin (2)

Personnel Required

Unit Mechanic

Materials/Parts

Bushing

Long spring pin (2)

Locknut (2)

Equipment Condition

Engine stopped (see your -10)

Carrier blocked (see your -10)

REPLACE/REPAIR RADIO OPERATOR'S SEAT (M1068A3 AND M58 ONLY) —
Continued

0568 00

REMOVAL

1. Remove two locknuts (1), two washers (2), two screws (3), four washers (M1068A3 only) (4), and seat belts (5) from radio operator's seat (6). Discard locknuts.
2. Remove four screws (7), lockwashers (M58 only) (8), washers (9), and radio operator's seat (6) from carrier.

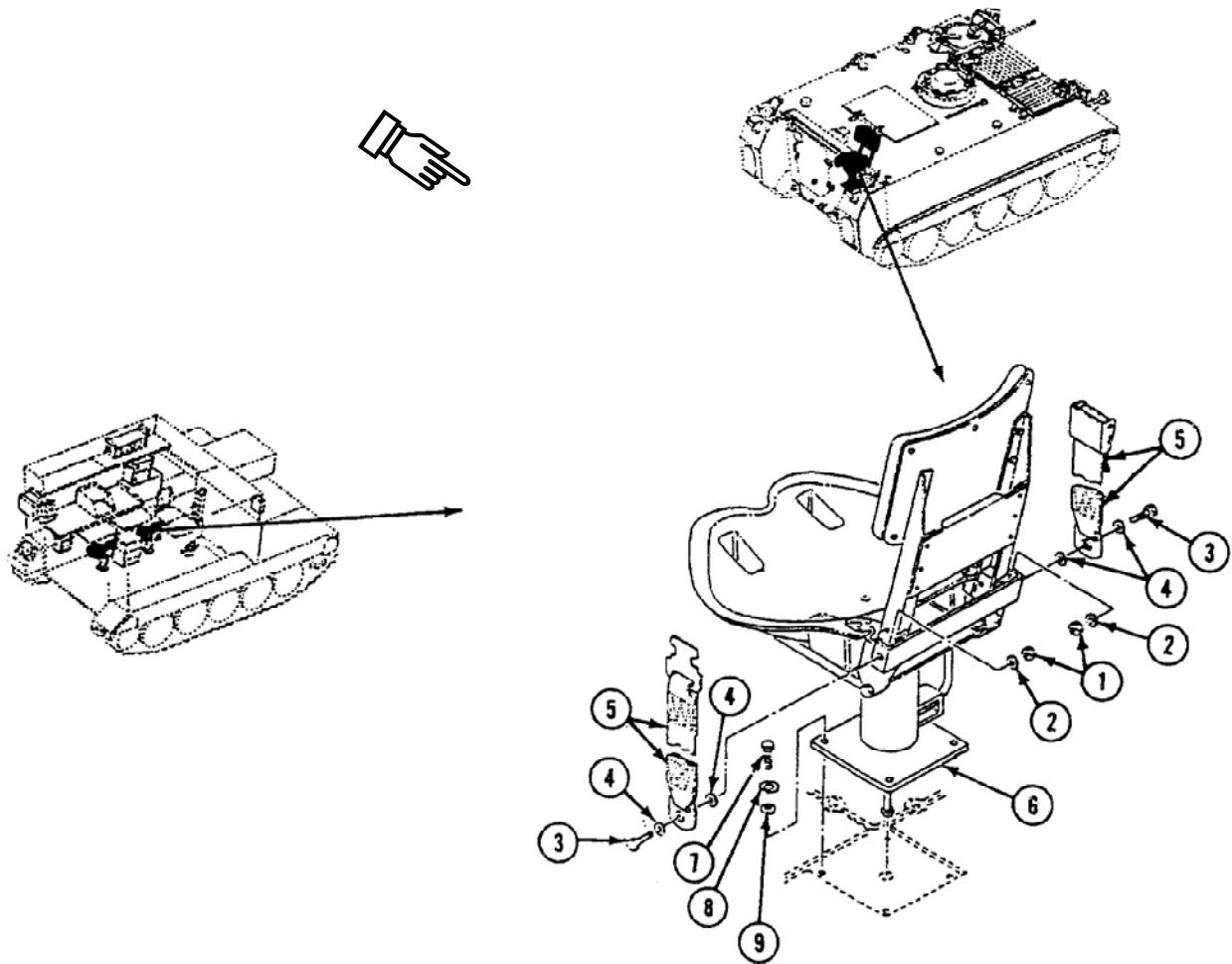

DISASSEMBLY

1. Remove four screws (1), washers (2), and backrest (3) from back brace (4). Lift back brace off seat.
2. Remove seat cushion (5) from seat (6).
3. Remove six locknuts (7), washers (8), screws (9), and two clips (10) from seat (6). Discard locknuts.
4. Remove two screws (11), lockwashers (12), spacers (13), and bracket (14) from two rails (15). Discard lockwashers.
5. Remove eight screws (16) and seat (6) from two rails (15).
6. Remove two short spring pins (17) from handle (18). Discard spring pins.
7. Remove handle (18), spring (19), and latch (20) from seat (6).
8. Remove two long spring pins (21) from seat (6). Discard spring pins.

REPLACE/REPAIR RADIO OPERATOR'S SEAT (M1068A3 AND M58 ONLY) —
Continued

0568 00

NOTE

If inspection shows that bushing (22) needs to be replaced, perform Step 9. Be careful. Do not damage seat when straightening ends.

9. Straighten ends and remove bushing (22) from seat (6). Discard bushing.
10. If locknut(s) (23) need to be replaced, drive out old locknut(s) from seat (6). Discard locknut(s).

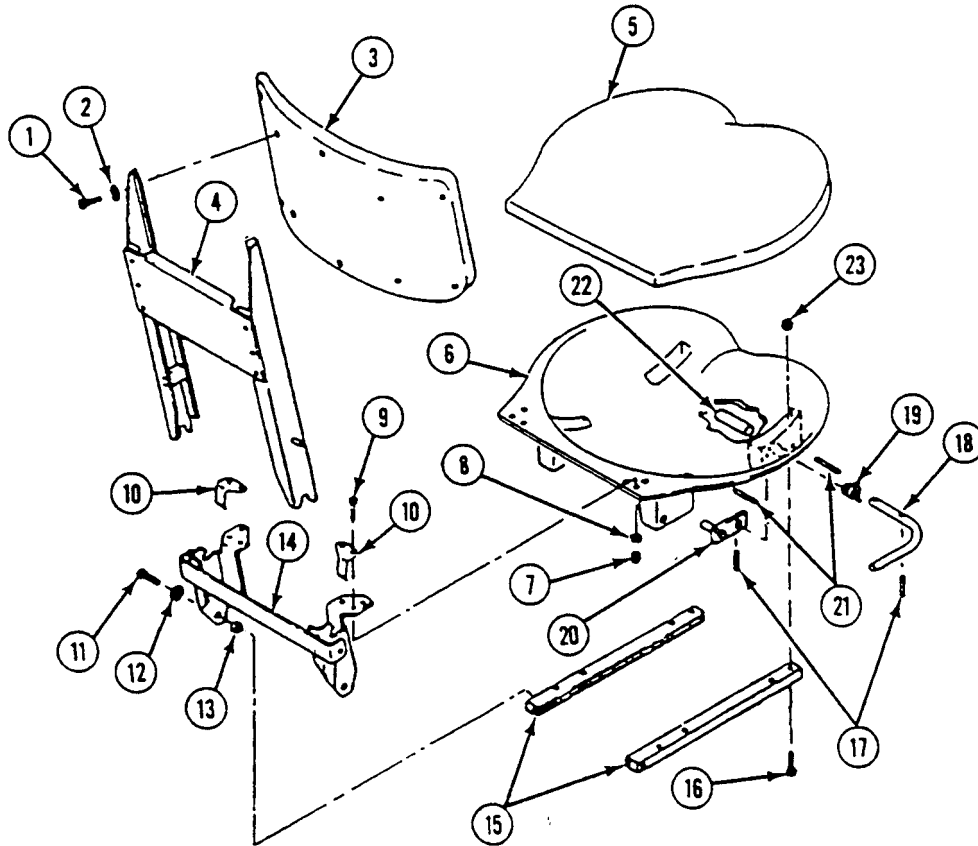

REPLACE/REPAIR RADIO OPERATOR'S SEAT (M1068A3 AND M58 ONLY) —
Continued

0568 00

11. Remove two locknuts (1), screws (2), washers (3), and rack (4) from support plate (5). Discard locknuts.
12. Remove four screws (6), locknuts (7), eight washers (8), and support plate (5) from tube (9). Discard locknuts.
13. Pull handle (1) and push tube (9) down to its lowest position. Hold rod (11) and remove locknut (12) and washer (13) from rod. Discard locknut.

WARNING

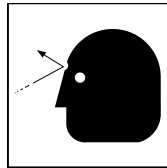

Apply pressure on tube to prevent spring from releasing when handle is pulled out. Injury to personnel can result from flying tube and spring.

14. While pushing down on tube (9), pull out handle (10) and slowly allow spring (14) to expand.
15. Remove rod (11), tube (9), and spring (14), from pedestal (15).
16. Remove pin (16), handle (10), spring (17), and washer (18) from tube (9).

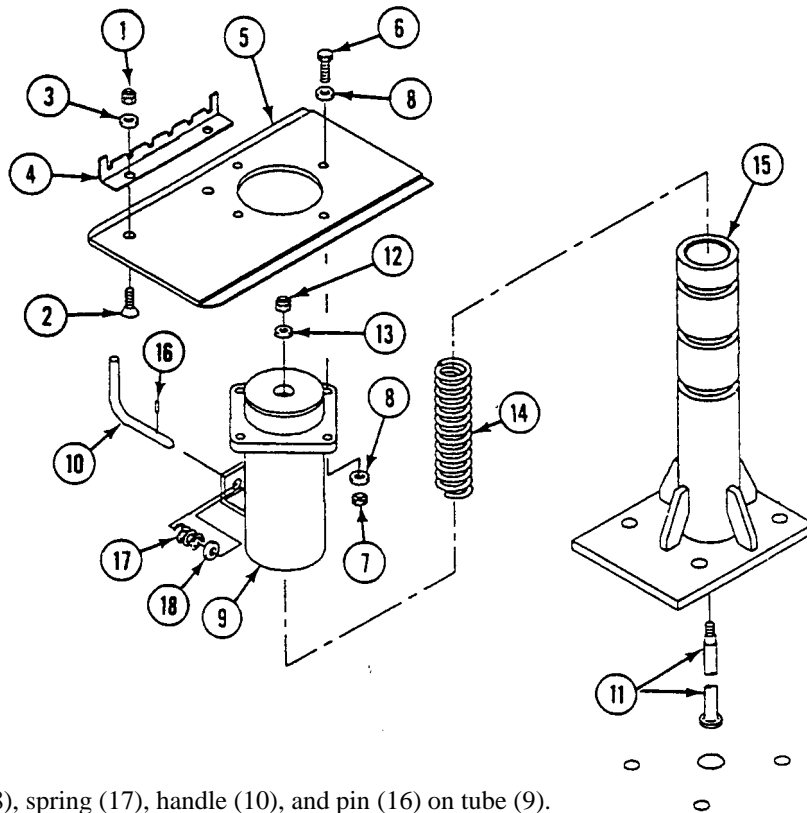

ASSEMBLY

1. Install washer (18), spring (17), handle (10), and pin (16) on tube (9).
2. Install spring (14), tube (9), and rod (11) on pedestal (15).
3. Install tube (9). Push down on tube and lock handle (10) in the lowest position.
4. Hold rod (11) and install washer (13) and new locknut (12) on rod.

REPLACE/REPAIR RADIO OPERATOR'S SEAT (M1068A3 AND M58 ONLY) —
Continued

0568 00

5. Install support plate (5), eight washers (8), four screws (6), and new locknuts (7) on tube (9). TIGHTEN SCREWS TO 80-90 IN-LB (9.0-10.1 N·m) TORQUE.
6. Install rack (4), two washers (3), screws (2), and new locknuts (1) on support plate (5).

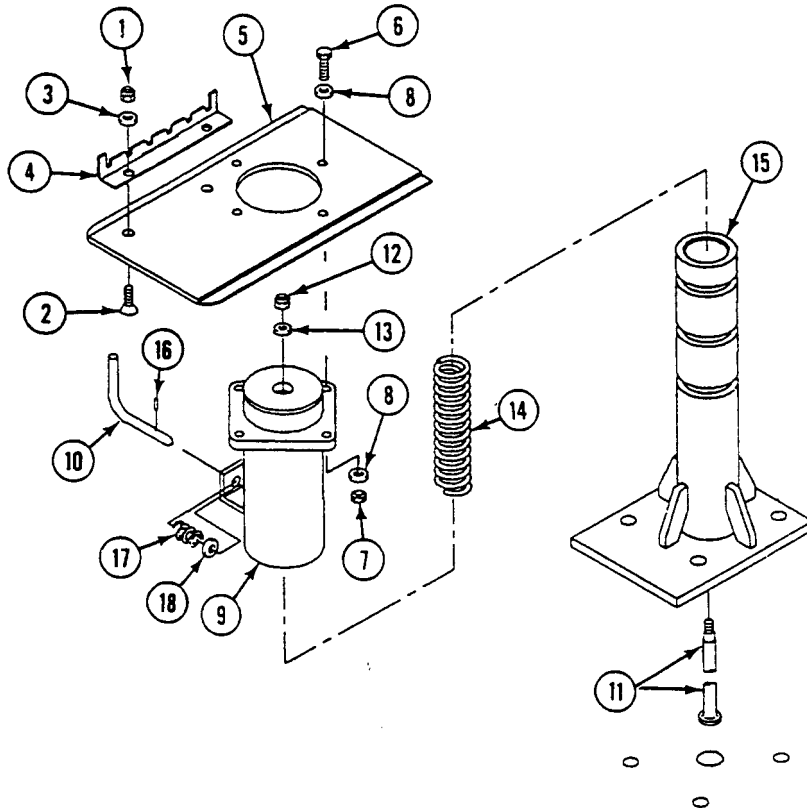

7. If removed, install new bushing (1) in seat (2). Peen both ends snugly to seat and secure.
8. Install two new long spring pins (3) in seat (2).

NOTE

If handle (4) is replaced, use latch (5) as a template, and drill 1/8 inch (3 mm) hole in handle for spring pin (6).

9. Install latch (5), spring (7), and handle (4) in seat (2). Secure with two new short spring pins (6).
10. If locknut(s) (8) was removed, install new locknut(s) (8) in seat (2).
11. Secure seat (2) to rails (9) with eight screws (10).
12. Align backrest bracket (11) and two spacers (12) with two rails (9). Secure with two new lockwashers (13) and screws (14).
13. Align two clips (15) and bracket (11) with seat (2). Secure with six screws (16), washers (17), and new locknuts (18).
14. Install seat cushion (19) on seat (2).
15. Install back brace (20) in bracket (11).

REPLACE/REPAIR RADIO OPERATOR'S SEAT (M1068A3 AND M58 ONLY) —
Continued

0568 00

16. Align backrest (21) with back brace (20). Secure with four washers (22) and screws (23).

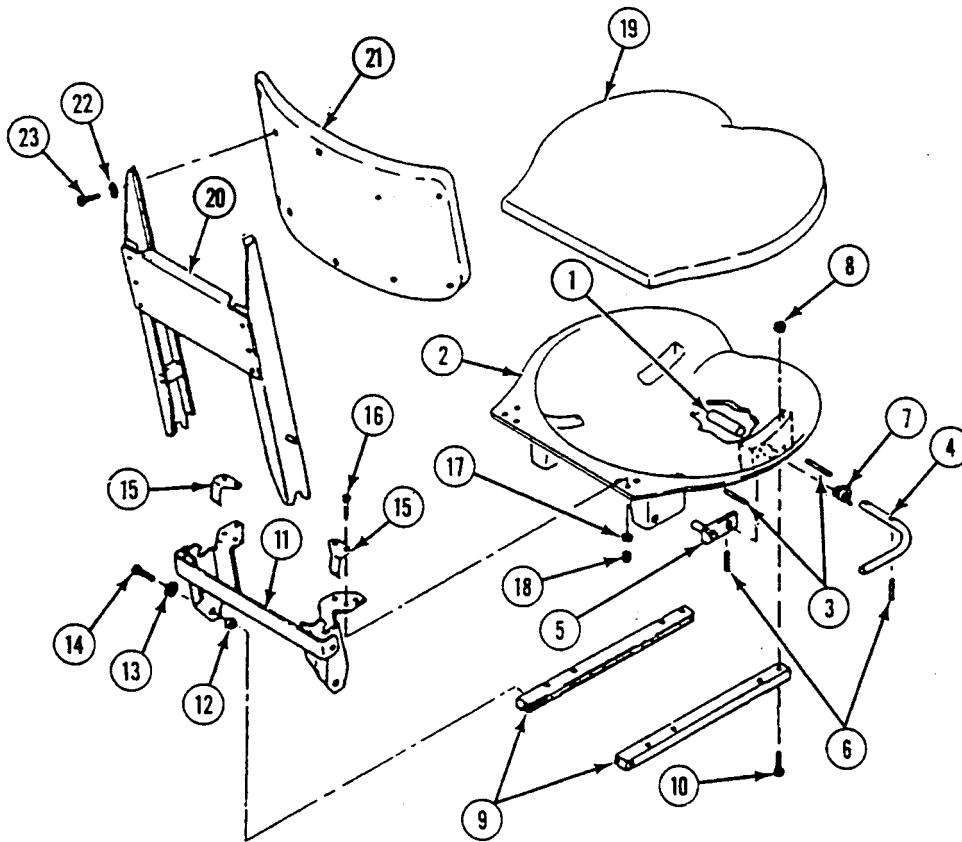

INSTALLATION

1. Position radio operator's seat (1) in carrier. Secure with four washers (2), screws (3), and new lockwashers (M58 only) (4).

**REPLACE/REPAIR RADIO OPERATOR'S SEAT (M1068A3, AND M58 ONLY) —
Continued**

0568 00

2. Position two seat belts (5) on radio operator's seat (1). Secure with two washers (6), two screws (7), four washers (M1068A3 only) (8), and two new locknuts (9).

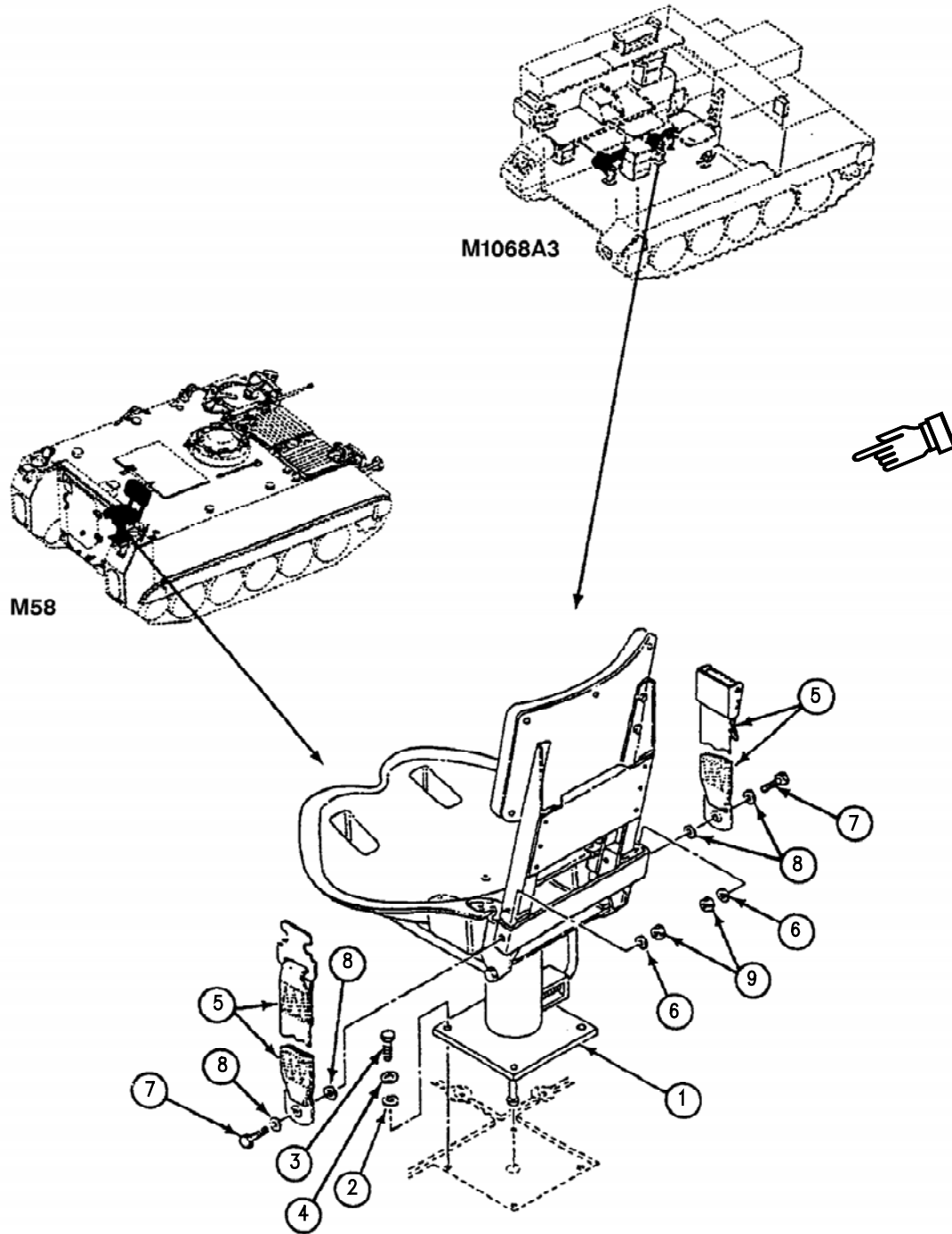

END OF TASK

REPLACE WEBBING STRAPS

0569 00

THIS WORK PACKAGE COVERS:

Removal (page 0569 00-1).
 Installation (page 0569 00-1).

INITIAL SETUP:

Maintenance Level

Unit

References

See your -10

Tools and Special Tools

General Mechanic's Tool Kit (WP 0926 00, Item 65)

Equipment Condition

Engine stopped (see your -10)

Personnel Required

Unit Mechanic

Carrier blocked (see your -10)

REMOVAL

NOTE

Webbing straps are normally belted on footman loops. See your -10 for strap locations.

NOTE

See your -10 for stowage location and proper strapping.

1. Release buckle and remove strap (1) from footman loop (2).

INSTALLATION

1. Pass strap (1) through footman loop (2) and secure with buckle.

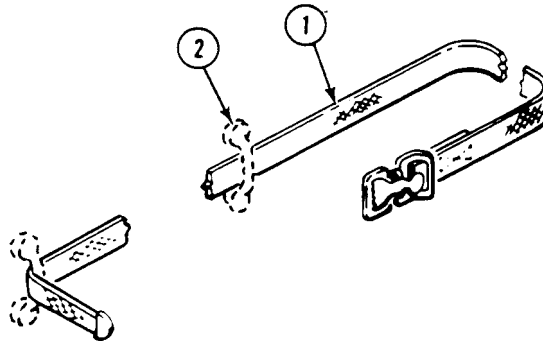

END OF TASK

REPLACE CUSHIONING PADS

0570 00

THIS WORK PACKAGE COVERS:

Removal (page 0570 00-1).
 Installation (page 0570 00-1).

INITIAL SETUP:

Maintenance Level

Unit

Personnel Required

Unit Mechanic

Tools and Special Tools

General Mechanic's Tool Kit (WP 0926 00, Item 65)

References

See your -10

Materials/Parts

Adhesive (WP 0928 00, Item 4)

Cleaning Compound (WP 0928 00, Item 17)

Equipment Condition

Engine stopped (see your -10)

Carrier blocked (see your -10)

REMOVAL

NOTE

Cushioning pads are used at various stowage locations (pioneer tools, tow cables, etc.). All pads are replaced the same way. Replace only cut, torn, or hard pads.

1. Using putty knife or similar tool, lift corner of cushioning pad and peel pad from hull.
2. Scrape any remaining adhesive from hull.

INSTALLATION

1. Thoroughly clean hull mating surface with cleaning compound.
2. Apply thin coat of adhesive to hull mating surface and back of new pad.
3. Allow 10 to 20 minutes for adhesive to dry. Surface should be tacky, but not too sticky. Warmer temperature will speed drying time.
4. Position pad on hull and press firmly into place.

END OF TASK

REPLACE TOOL BOX LOOPS

0571 00

THIS WORK PACKAGE COVERS:

Removal (page 0571 00-1).
 Installation (page 0571 00-2).

INITIAL SETUP:

Maintenance Level

Unit

References

See your -10

Tools and Special Tools

General Mechanic's Tool Kit (WP 0926 00, Item 65)

Equipment Condition

Engine stopped (see your -10)
 Carrier blocked (see your -10)
 Ramp lowered (see your -10)
 Battery cover removed (see your -10)
 Strap removed (WP 0569 00)

Personnel Required

Unit Mechanic

REMOVAL

1. Remove four nuts (1), screws (2), eight washers (3), and two tool box loops (4) from battery box cover (5).

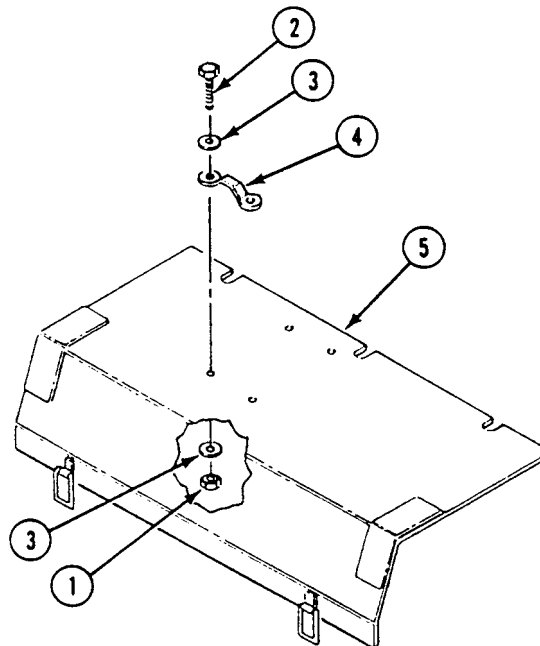

INSTALLATION

1. Install two tool box loops (4), four screws (2), eight washers (3), and four nuts (1) on battery box cover (5).

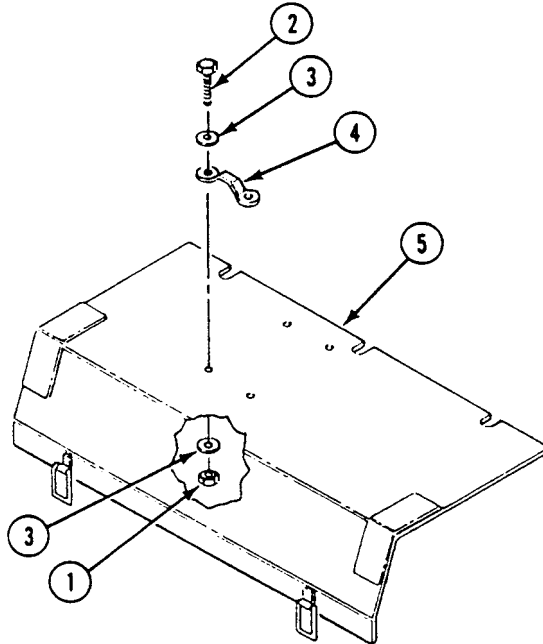
**FOLLOW-THROUGH STEPS**

1. Install strap (WP 0569 00).
2. Install battery cover (see your -10).
3. Raise and lock ramp (see your -10).

END OF TASK

REPLACE AN/VVS-2 DRIVER'S NIGHT VISION STOWAGE MOUNT (ALL EXCEPT M58)

0572 00

THIS WORK PACKAGE COVERS:

Removal (page 0572 00-1).
 Installation (page 0572 00-2).

INITIAL SETUP:

Maintenance Level

Unit

References

See your -10
 TM 11-5855-249-10

Tools and Special Tools

General Mechanic's Tool Kit (WP 0926 00, Item 65)

Materials/Parts

Lockwasher (4)

Equipment Condition

Engine stopped (see your -10)
 Carrier blocked (see your -10)

Personnel Required

Unit Mechanic

REMOVAL

1. Remove strap (1), cover (2), and viewer (3) or plug from bracket (4).
2. Remove four nuts (5), lockwashers (6), washers (7), and bracket (4) from mount (8). Discard lockwashers.
3. Remove four mounts (8) from weldnuts.

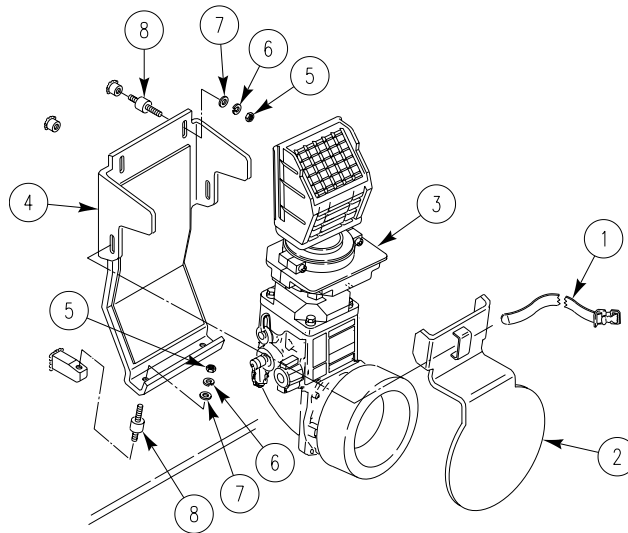

REPLACE AN/VVS-2 DRIVER'S NIGHT VISION STOWAGE MOUNT (ALL EXCEPT M58) —
Continued

0572 00

INSTALLATION

1. Install four mounts (8) on weldnuts.
2. Install bracket (4), four washers (7), new lockwashers (6), and nuts (5) on mounts (8).
3. Install viewer (3) or plug, cover (2), and strap (1) on bracket (4).

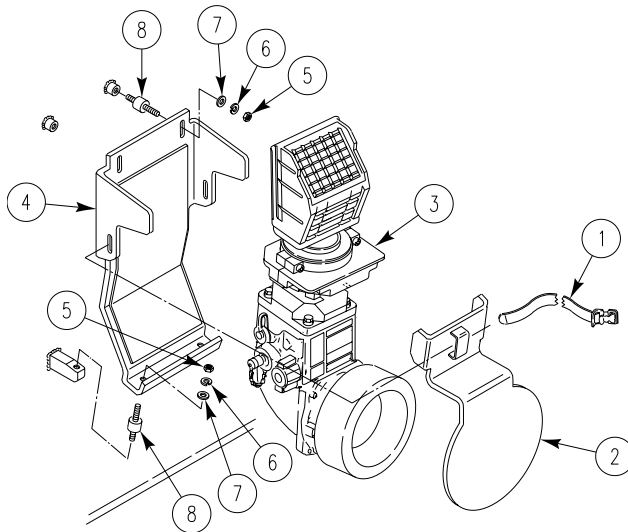
**END OF TASK**

REPLACE RIFLE BRACKETS

0573 00

THIS WORK PACKAGE COVERS:

Removal (page 0573 00-1).
 Installation (page 0573 00-2).

INITIAL SETUP:

Maintenance Level

Unit

Personnel Required

Unit Mechanic

Tools and Special Tools

General Mechanic's Tool Kit (WP 0926 00, Item 65)

References

See your -10

Materials/Parts

Locknut (3)

Equipment Condition

Engine stopped (see your -10)
 Carrier blocked (see your -10)

REMOVAL

1. Remove locknut (1), screw (2), and front bracket (3) from hull mount. Discard locknut.
2. Remove two locknuts (4), screws (5), and clip (6) from hull mount. Discard locknuts.

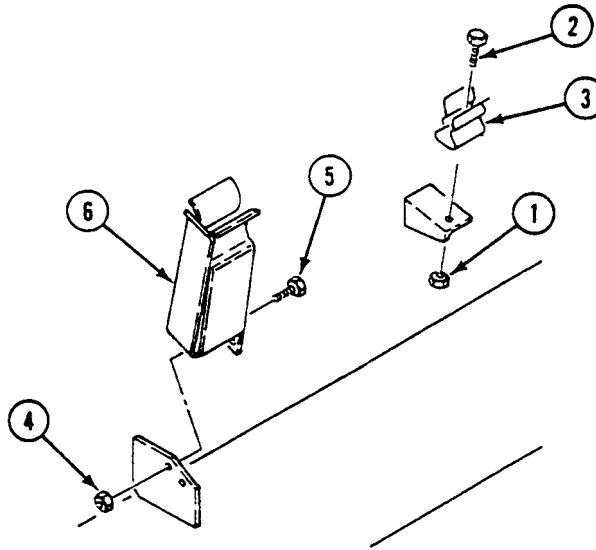

INSTALLATION

1. Align clip (6) with hull mount. Secure with two screws (5) and new locknuts (4).
2. Align front bracket (3) with hull mount. Secure with screw (2) and new locknut (1).

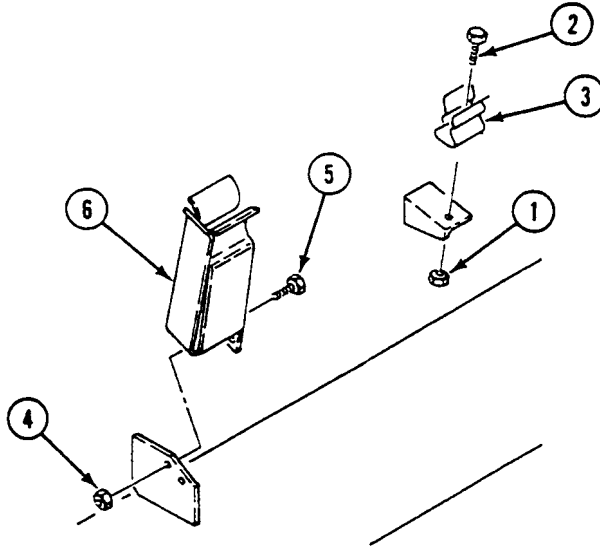
**END OF TASK**

REPLACE OIL CAN BRACKET

0574 00

THIS WORK PACKAGE COVERS:

- Removal (page 0574 00-1).
- Installation (page 0574 00-1).

INITIAL SETUP:

Maintenance Level

Unit

References

See your -10

Tools and Special Tools

- General Mechanic's Tool Kit (WP 0926 00, Item 65)
- Torque Wrench (WP 0926 00, Item 84)

Equipment Condition

- Engine stopped (see your -10)
- Carrier blocked (see your -10)
- Trim vane lowered (see your -10)
- Power plant access door open (see your -10)

Personnel Required

Unit Mechanic

REMOVAL

1. Remove two screws (1), washers (2), and oil can bracket (3) from power plant compartment.

INSTALLATION

1. Align oil can bracket (3) with bulkhead in power plant compartment. Secure with two washers (2) and screws (1). TIGHTEN SCREWS TO 22-24 LB-FT (30-33 N·m) TORQUE.

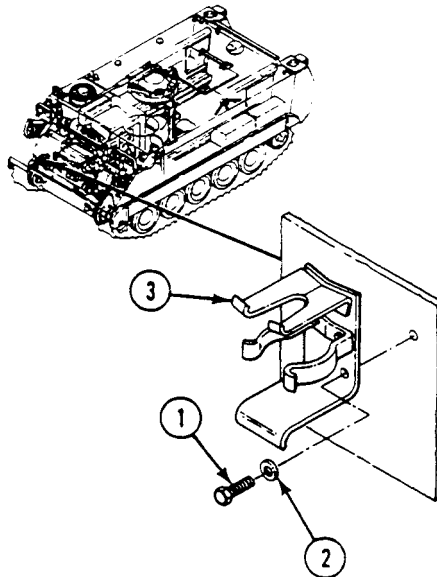

FOLLOW-THROUGH STEPS

1. Close power plant access door (see your -10).
2. Raise trim vane (see your -10).

END OF TASK

REPLACE ANTENNA GUARDS

0575 00

THIS WORK PACKAGE COVERS:

Removal (page 0575 00-1).
 Installation (page 0575 00-2).

INITIAL SETUP:

Maintenance Level

Unit

Personnel Required

Unit Mechanic

Tools and Special Tools

General Mechanic's Tool Kit (WP 0926 00, Item 65)

References

See your -10

Materials/Parts

Locknut (3)

Equipment Condition

Engine stopped (see your -10)
 Carrier blocked (see your -10)

REMOVAL

1. Remove three screws (1), washers (2), and guard (3) from hull top plate.
2. Remove three screws (4), locknuts (5), and guard (6) from bracket on hull top plate. Discard locknuts.

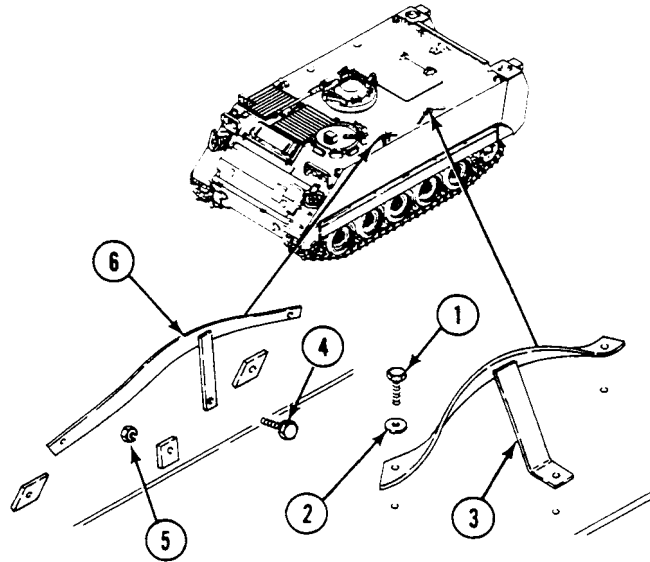

INSTALLATION

1. Align guard (6) with brackets on hull top plate. Secure with three screws (4) and new locknuts (5).
2. Align guard (3) with hull top plate. Secure with three washers (2) and screws (1).

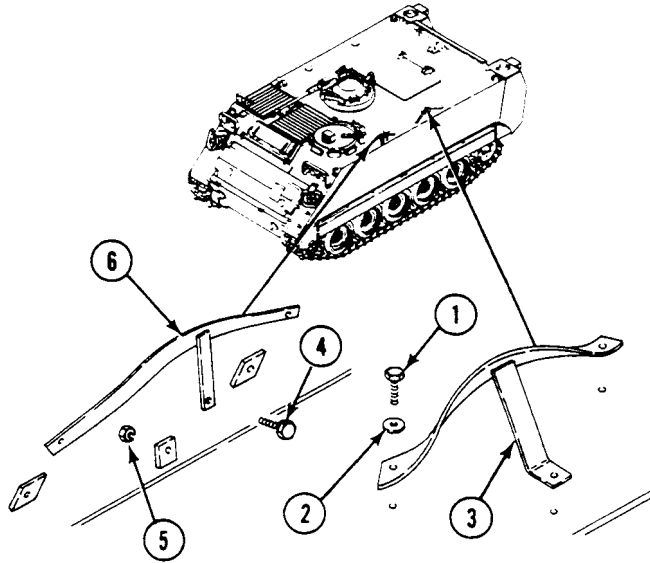
**END OF TASK**

REPLACE T150 TRACK SHOE STOWAGE BRACKET

0575 01

THIS WORK PACKAGE COVERS:

Removal (page 0575 01-1)

Installation (page 0575 01-2)

INITIAL SETUP:

Maintenance Level

Unit

Tools and Special Tools

General Mechanic's Tool Kit (WP 0926 00, Item 65)

Personnel Required

Unit Mechanic

References

See your -10

Equipment Conditions

Engine Stopped (see your -10)

Carrier Blocked (see your-10)

REMOVAL

NOTE

There are two brackets to stow track shoes. Both are replaced the same way, only one is shown.

1. Remove two screws (1), flat washers (2), square flat washers (3), and track shoe assembly (4) from vehicle.
2. Remove two screws (7), flat washers (6), and bracket (5) from vehicle.

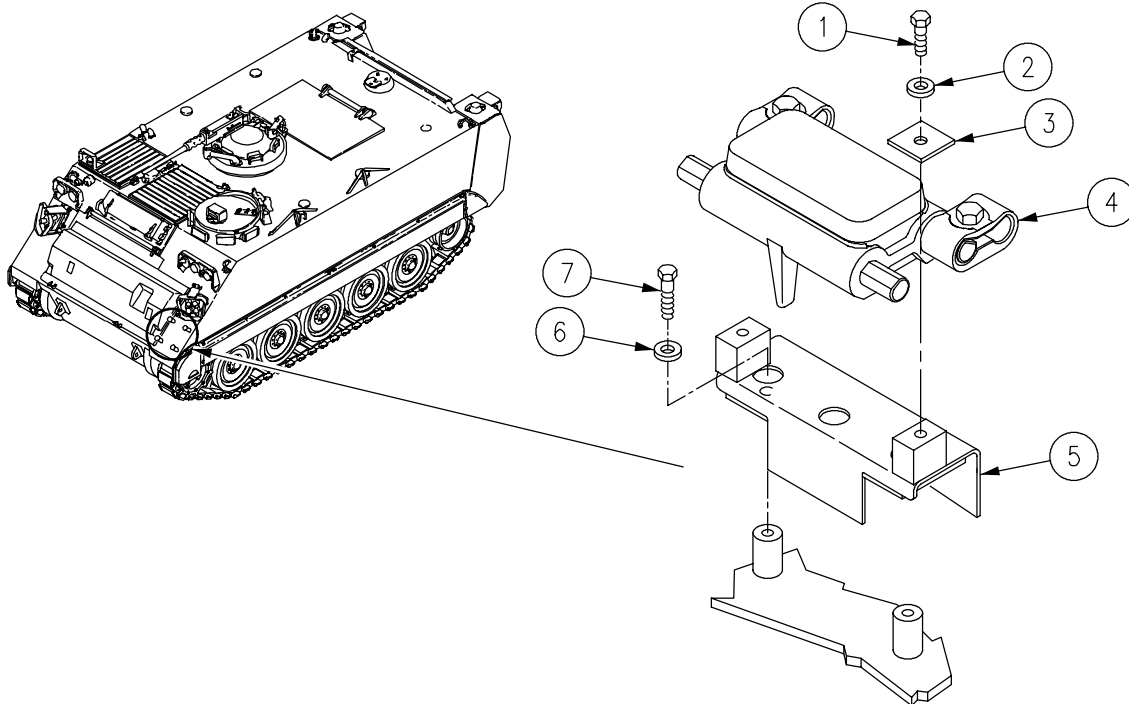

REPLACE T150 TRACK SHOE STOWAGE BRACKET - Continued

0575 01

INSTALLATION

1. Install bracket (5) on vehicle and secure with two flat washers (6), and screws (7).
2. Install track shoe assembly (4) on vehicle and secure with two square flat washers (3), flat washers (2), and screws (1).

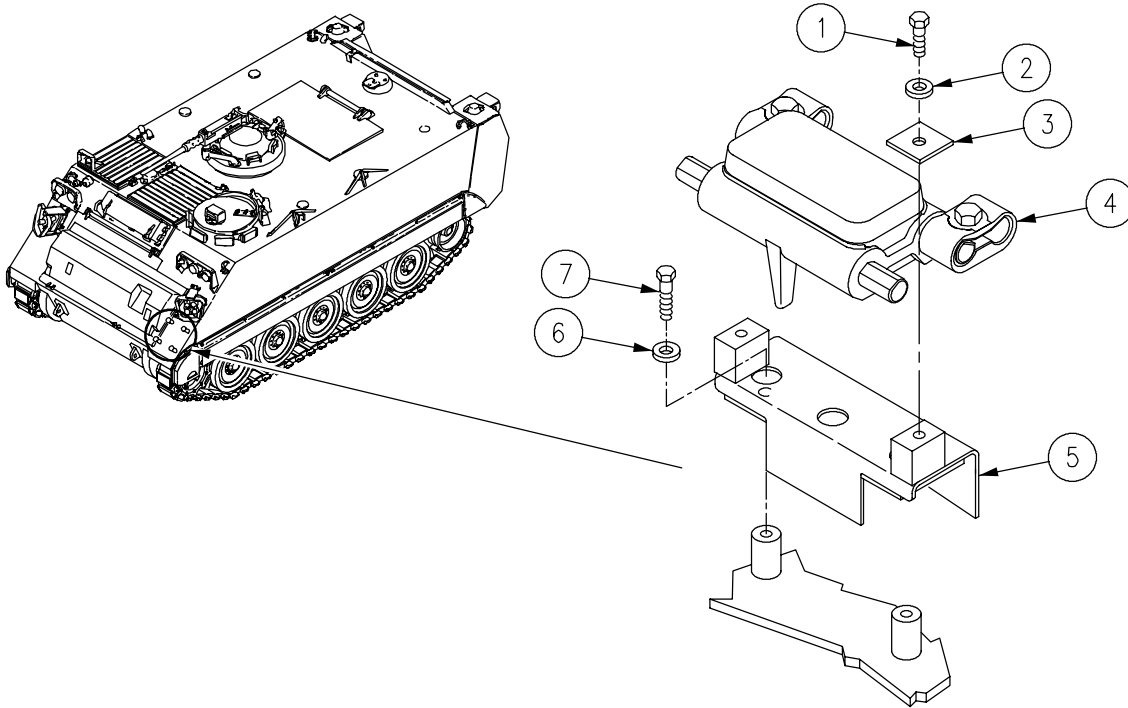

END OF TASK

REPLACE ANTENNA COVERS

0576 00

THIS WORK PACKAGE COVERS:

Removal (page 0576 00-1).
 Installation (page 0576 00-2).

INITIAL SETUP:

Maintenance Level

Unit

Personnel Required

Unit Mechanic

Tools and Special Tools

General Mechanic's Tool Kit (WP 0926 00, Item 65)

References

See your -10

Materials/Parts

Gasket (2)

Equipment Condition

Engine stopped (see your -10).
 Carrier blocked (see your -10).

REMOVAL

NOTE

Screws and adapters are different sizes for different locations. Remove and install one cover at a time.

On some locations, adapter is not installed.

1. Remove four screws (1), two gaskets (2), adapter (3), and cover (4) from hull top plate. Discard gaskets.

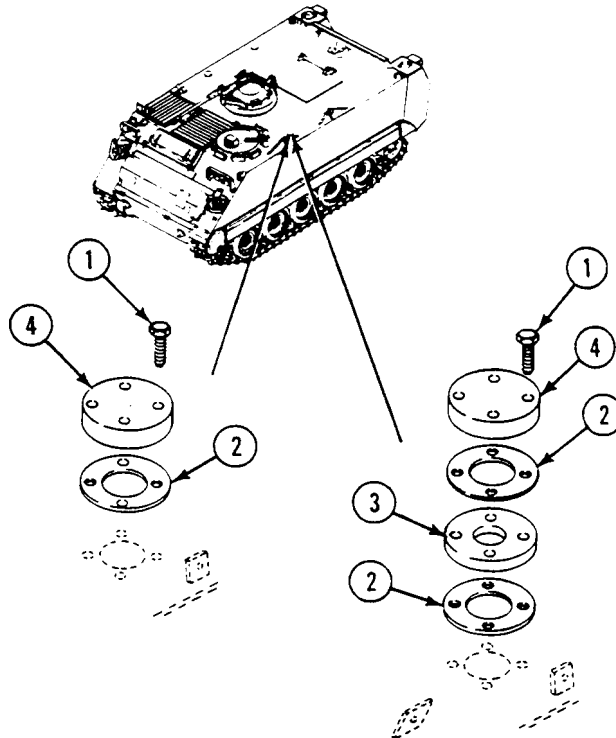

INSTALLATION

1. Align one new gasket (2), adapter (3), one new gasket (2), and cover (4) with hull top plate. Secure with four screws (1).

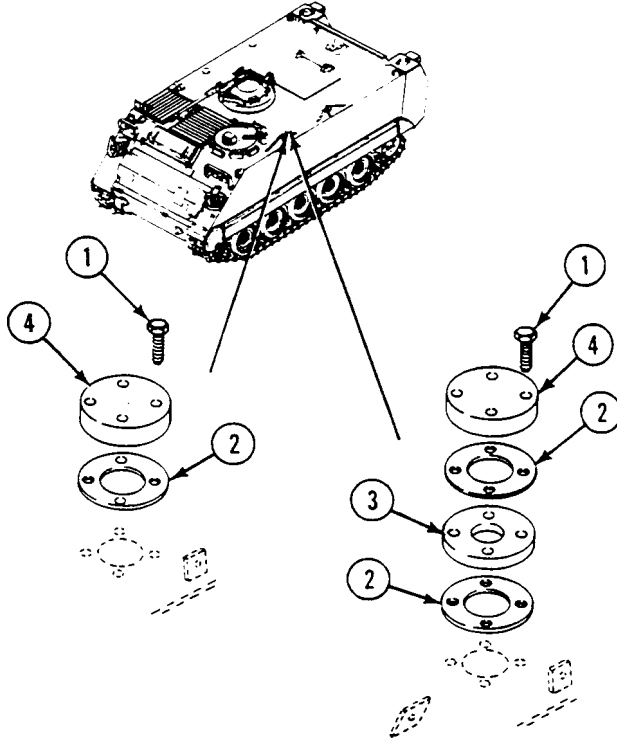

END OF TASK

REPLACE LEFT BULKHEAD RADIO STOWAGE RACKS (M577A3 AND M1068A3 ONLY)

0577 00

THIS WORK PACKAGE COVERS:

Removal (page 0577 00-1).
 Installation (page 0577 00-2).

INITIAL SETUP:

Maintenance Level

Unit

Personnel Required

Unit Mechanic

Tools and Special Tools

General Mechanic's Tool Kit (WP 0926 00, Item 65)

References

See your -10

Materials/Parts

Locknut (12)

Lockwasher (12)

Equipment Condition

Engine stopped (see your -10)

Carrier blocked (see your -10)

Ramp lowered (see your -10)

REMOVAL

1. Remove locknut (1), two lockwashers (2), and screw (3) from hanger (4), front rack (5), and rear rack (6). Discard lockwashers and locknut.
2. Remove locknut (7), two lockwashers (8), screw (9), and hanger (4) from hull top plate lug. Discard lockwashers and locknut.
3. Remove locknut (10), two lockwashers (11), and screw (12) from rack (5), rack (6), and bulkhead lug. Discard lockwashers and locknut.
4. Remove locknut (13), two lockwashers (14), washers (15), and screw (16) from each rack (5) and (6). Discard lockwashers and locknut.
5. Remove two locknuts (17), four lock-washers (18), and two screws (19) from each rack (5) and (6). Discard lockwashers and locknuts.

REPLACE LEFT BULKHEAD RADIO STOWAGE RACKS (M577A3 AND M1068A3 ONLY)
— Continued

0577 00

- Remove six locknuts (20), screws (21), and three intercom brackets (22) from rack (6). Discard locknuts.

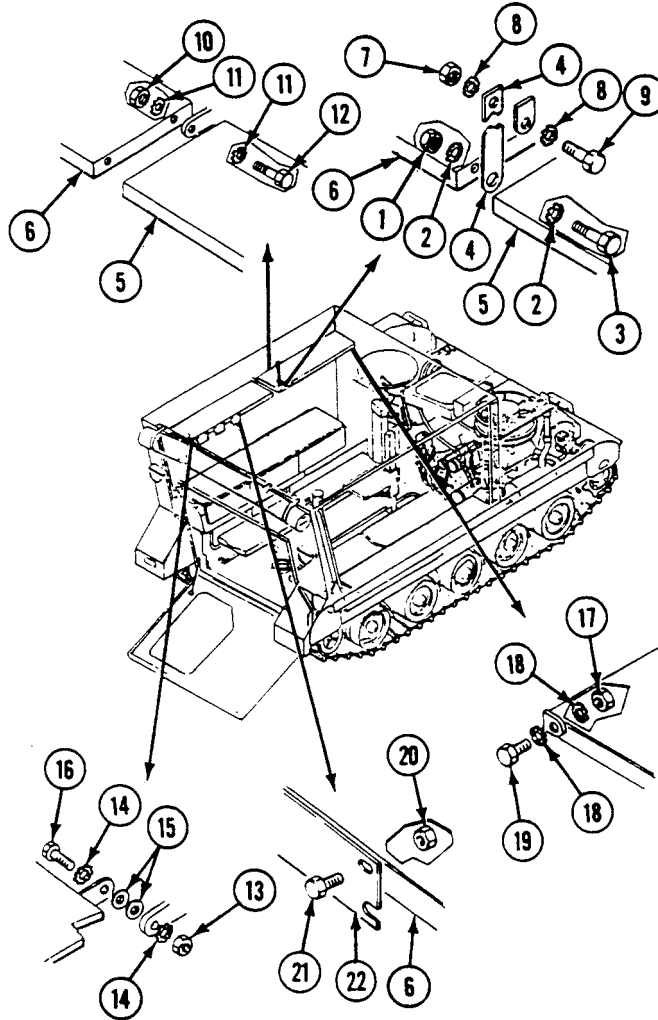

INSTALLATION

- Align three intercom brackets (1) with rack (2). Secure with six screws (3) and new locknuts (4).

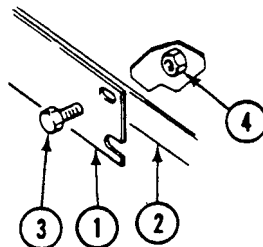

REPLACE LEFT BULKHEAD RADIO STOWAGE RACKS (M577A3 AND M1068A3 ONLY)

0577 00

— Continued

- Align racks (5) and (2) with front and rear bulkhead lugs. Secure with two screws (6), four new lockwashers (7), and two new locknuts (8) on each rack.

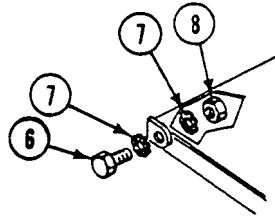

- Align racks (5) and (2) to left bulkhead lugs. Secure with screw (9), washer(s) (10) (to shim), two new lockwashers (11), and new locknut (12) on each rack.

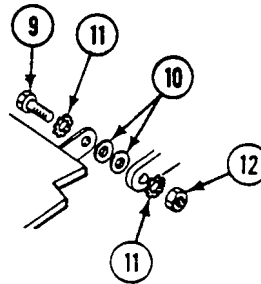

- Align racks (5) and (2) with left bulkhead lug. Secure with screw (13), two new lockwashers (14), and new locknut (15).

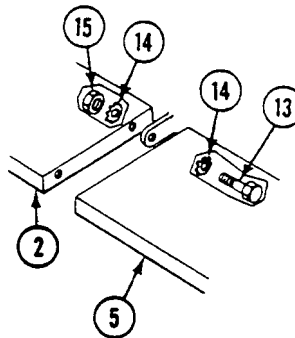

REPLACE LEFT BULKHEAD RADIO STOWAGE RACKS (M577A3 AND M1068A3 ONLY)

0577 00**— Continued**

5. Align hanger (16) with hull top plate lug. Secure with screw (17), two new lockwashers (18), and new locknut (19).
6. Align hanger (16) with rear rack (2) and front rack (5). Secure with screw (20), two new lockwashers (21), and new locknut (22).

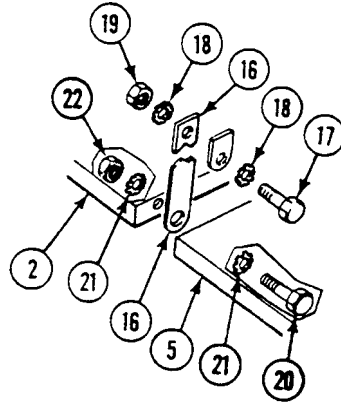
**FOLLOW-THROUGH STEPS**

1. Start engine (see your -10).
2. Raise and lock ramp (see your -10).
3. Stop engine (see your -10).

END OF TASK

REPLACE LEFT TABLE (M577A3 ONLY)

0578 00

THIS WORK PACKAGE COVERS:

Removal (page 0578 00-1).
 Installation (page 0578 00-3).

INITIAL SETUP:

Maintenance Level

Unit

Personnel Required

Unit Mechanic

Tools and Special Tools

General Mechanic's Tool Kit (WP 0926 00, Item 65)

References

See your -10

Materials/Parts

Locknut (3)
 Locknut (18)
 Locknut

Equipment Condition

Engine stopped (see your -10)
 Carrier blocked (see your -10)
 Ramp lowered (see your -10)

REMOVAL

1. Remove 24 screws (1), 12 spacers (2), and three drop leaves (3)(4)(5) from table top (6).
2. Remove 24 screws (7), 12 spacers (8), hinges (9), and six supports (10) thru (15) from table top (6).
3. Remove three locknuts (16), washers (17), screws (18), and supports (10) thru (15) from hull. Discard locknuts.
4. Remove 18 locknuts (19), washers (20), screws (21), and six braces (22) from supports (10) thru (15). Discard locknuts.
5. Remove six bumpers (23) from braces (22).
6. Remove locknut (24), screw (25), and clamp (26) from support (10). Discard locknut.
7. Remove 12 screws (27), washers (28), and six catches (29) from three drop leaves (3)(4)(5).

8. Remove four nuts (30), screws (31), washers (32), and table top (6) from hull.

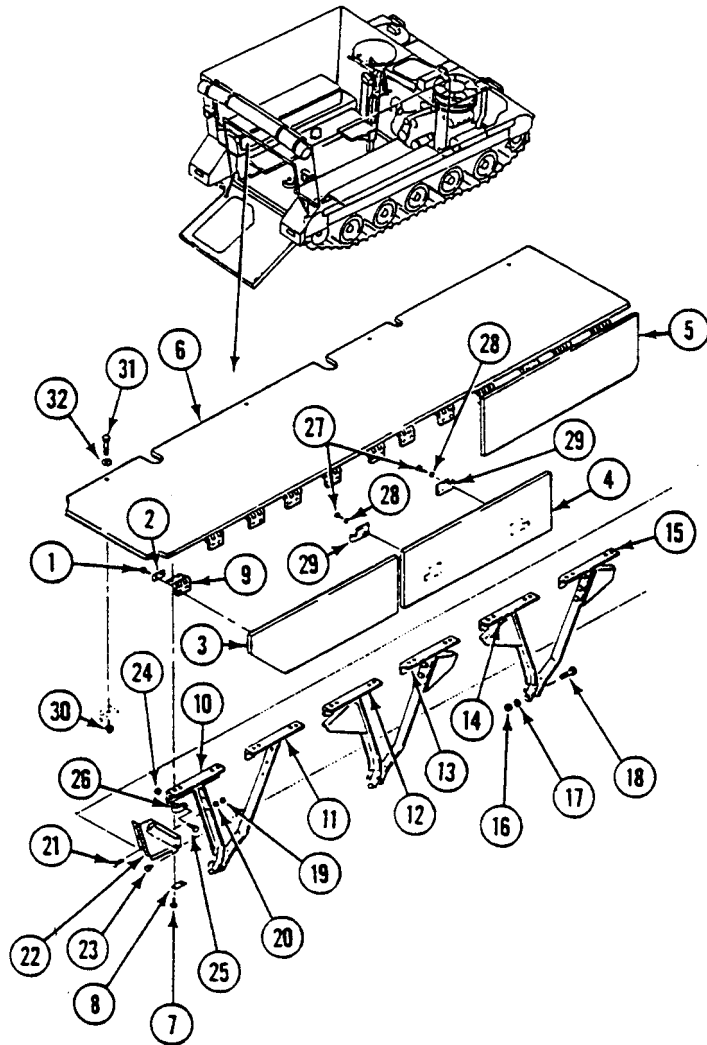

INSTALLATION

1. Install table top (1) on hull. Secure with four screws (2), washers (3), and nuts (4).
2. Install six catches (5) on three drop leaves (6)(7)(8). Secure with 12 washers (9) and screws (10).
3. Install clamp (11) on support (12). Secure with screw (13) and new locknut (14).
4. Install six bumpers (15) on braces (16).
5. Install six braces (16) on six supports (12) and (17) thru (21). Secure with 18 screws (22), washers (23), and new locknuts (24).
6. Install six supports (12) and (17) thru (21) on hull. Secure with three screws (25), washers (26), and new locknuts (27).
7. Install 12 hinges (28) and six supports (12) and (17) thru (21) on table top (1). Secure with 12 spacers (29) and 24 screws (30).
8. Install three drop leaves (6)(7)(8) on hinges (28). Secure with 12 spacers (31) and 24 screws (32).

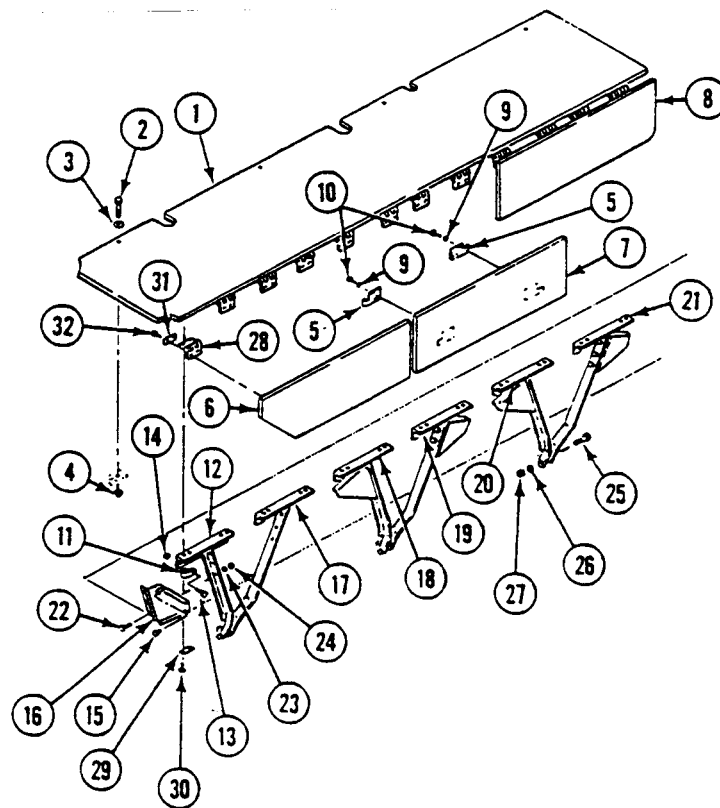
**FOLLOW-THROUGH STEPS**

1. Start engine (see your -10).
2. Raise and lock ramp (see your -10).
3. Stop engine (see your -10).

END OF TASK

REPLACE RIGHT FRONT RADIO STOWAGE RACK (M577A3 ONLY)

0579 00

THIS WORK PACKAGE COVERS:

Removal (page 0579 00-1).
 Installation (page 0579 00-1).

INITIAL SETUP:

Maintenance Level

Unit

Personnel Required

Unit Mechanic

Tools and Special Tools

General Mechanic's Tool Kit (WP 0926 00, Item 65)

References

See your -10

Materials/Parts

Locknut (5)
 Lockwasher (10)

Equipment Condition

Engine stopped (see your -10)
 Carrier blocked (see your -10)
 Ramp lowered (see your -10)

REMOVAL

1. Remove four locknuts (1), eight lockwashers (2), four screws (3), and rack (4) from hanger (5) and bulkhead mounts. Discard locknuts and lockwashers.
2. Remove locknut (6), two lockwashers (7), screw (8), and hanger (5) from hull top plate mount. Discard locknut and lockwashers.

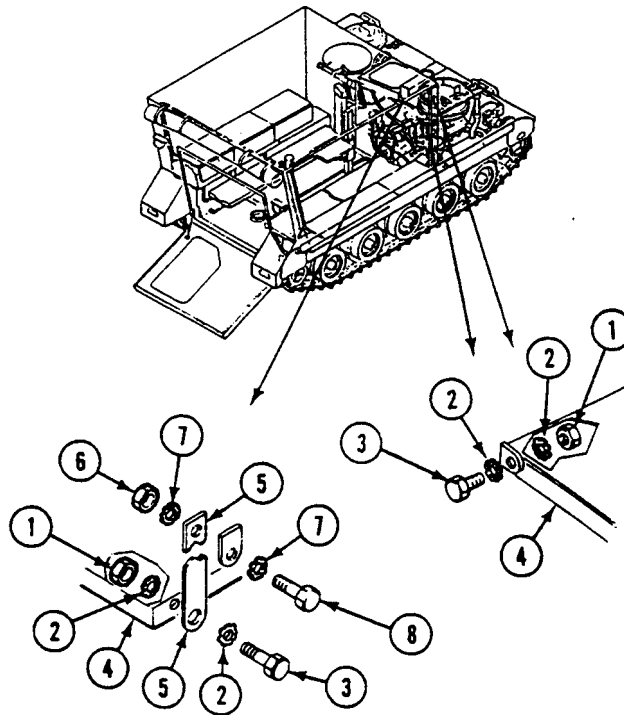

INSTALLATION

1. Align hanger (5) with hull top plate mount. Secure with screw (8), two new lockwashers (7), and new locknut (6).

REPLACE RIGHT FRONT RADIO STOWAGE RACK (M577A3 ONLY) — Continued**0579 00**

- Align rack (4) with hanger (5) and bulkhead mounts. Secure with four screws (3), eight new lockwashers (2), and four new locknuts (1).

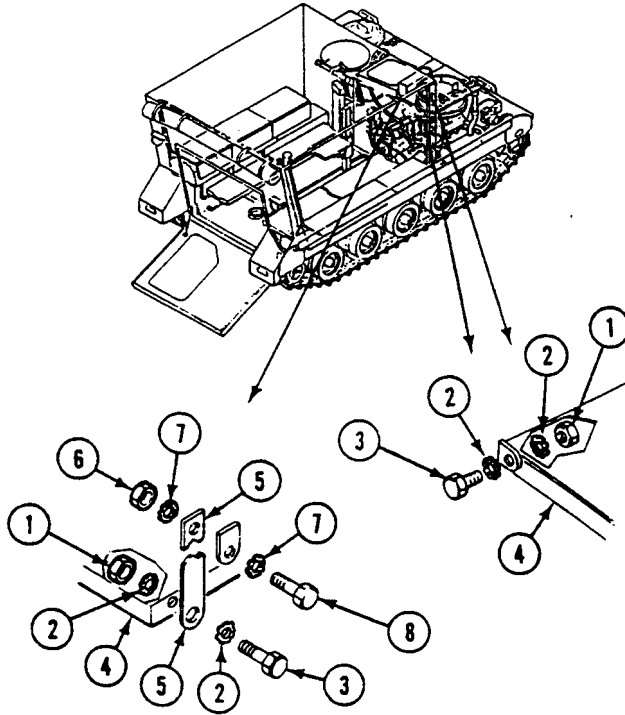
**FOLLOW-THROUGH STEPS**

- Start engine (see your -10).
- Raise and lock ramp (see your -10).
- Stop engine (see your -10).

END OF TASK

REPLACE MAP BOARD (M577A3 ONLY)

0580 00

THIS WORK PACKAGE COVERS:

Removal (page 0580 00-1).
 Installation (page 0580 00-2).

INITIAL SETUP:

Maintenance Level

Unit

Personnel Required

Unit Mechanic

Tools and Special Tools

General Mechanic's Tool Kit (WP 0926 00, Item 65)

References

See your -10

Materials/Parts

Cotter pin (2)
 Locknut (8)

Equipment Condition

Engine stopped (see your -10)
 Carrier blocked (see your -10)
 Ramp lowered (see your -10)

REMOVAL

1. Loosen two bolts (1) and clamps (2). Remove map board (3) from right bulkhead mounts.
2. Remove two cotter pins (4), bolts (1), clamps (2), spacers (5), and washers (6) from bulkhead stops. Discard cotter pins.
3. Remove two springs (7) from four brackets (8).
4. Remove four screws (9) and brackets (8) from map board (3).
5. Open one end of four hooks (10). Remove hooks from four chains (11).
6. Open both ends of four hooks (12). Remove hooks from four chains (11) and D-rings (13).

7. Remove eight locknuts (14), screws (15), four hangers (16), and D-rings (13) from map board (3). Discard locknuts.

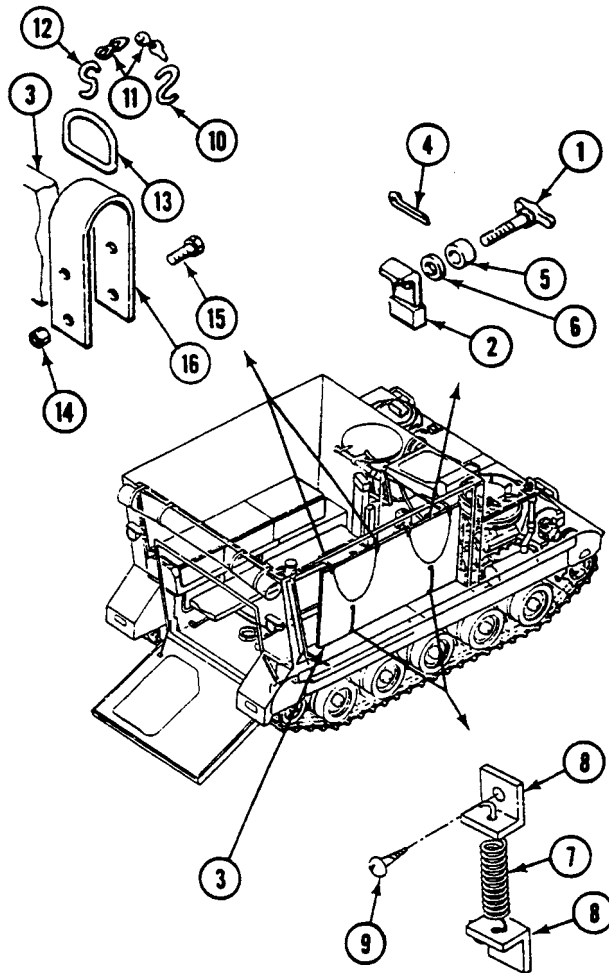

INSTALLATION

1. Pass four hangers (16) through four D-rings (13) and align hangers on map board (3). Secure hangers with eight screws (15) and new locknuts (14).
2. Install four hooks (12) on four D-rings (13) and chains (11). Squeeze both ends of hooks to secure.
3. Install four hooks (10) on four chains (11). Squeeze on end of hooks to secure.
4. Align four brackets (8) on map board (3). Secure with four screws (9).
5. Install two springs (7) on four brackets (8).
6. Install two clamps (2) on two bulkhead stops. Secure with two washers (6), spacers (5), bolts (1), and new cotter pins (4).

- Place map board (3) on right bulkhead mounts. Secure with two clamps (2) and bolts (1).

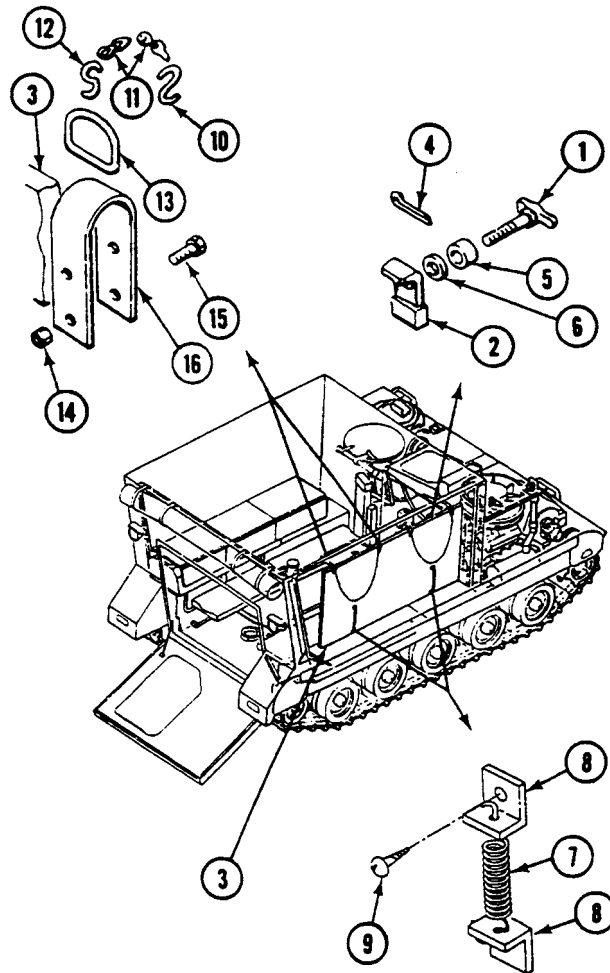

FOLLOW-THROUGH STEPS

- Start engine (see your -10).
- Raise and lock ramp (see your -10).
- Stop engine (see your -10).

END OF TASK

REPLACE RIGHT FORWARD TABLE (M577A3 ONLY)

0581 00

THIS WORK PACKAGE COVERS:

Removal (page 0581 00-1).
 Installation (page 0581 00-3).

INITIAL SETUP:

Maintenance Level

Unit

Personnel Required

Unit Mechanic

Tools and Special Tools

General Mechanic's Tool Kit (WP 0926 00, Item 65)

References

See your -10

Materials/Parts

Cotter Pin (2)
 Locknut (9)

Equipment Condition

Engine stopped (see your -10)
 Carrier blocked (see your -10)
 Ramp lowered (see your -10)

REMOVAL

1. Release two catches (1) on battery box from strikes (2).
2. Remove six screws (3), three key washers (4), and table top (5) from three hinges (6).
3. Remove six screws (7), locknuts (8) and three hinges (6) from hull. Discard locknuts.
4. Remove eight screws (9), four key washers (10), and two strikes (2) from table top (5).
5. Remove two cotter pins (11), washers (12), headless pin (13), and dropleaf rod (14) from radio rack (15) and bracket (16). Discard cotter pins.
6. Remove screw (17), locknut (18), washer (19), and clip (20) from bracket (16). Discard locknut.

7. Remove two screws (21), locknuts (22), washers (23), and bracket (16) from radio rack (15). Discard locknuts.

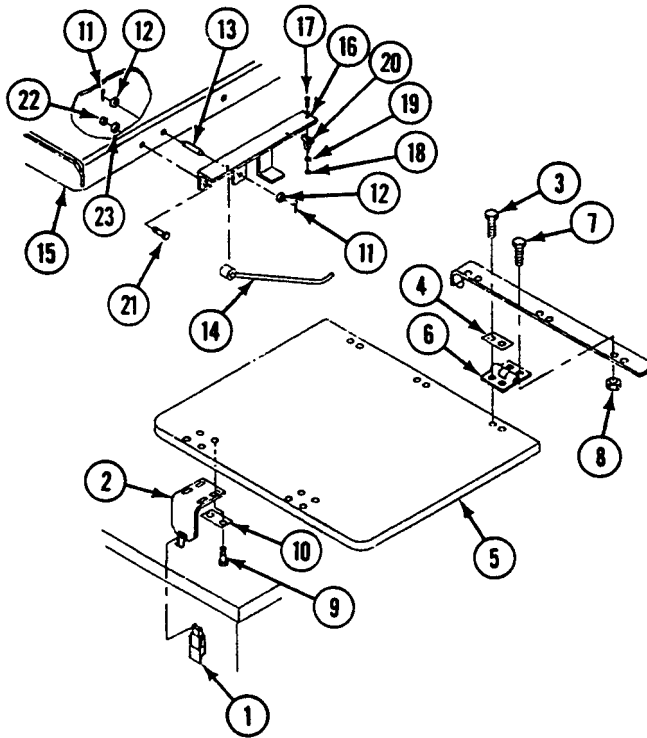

INSTALLATION

1. Position bracket (1) on radio rack (2) and secure with two screws (3), washers (4), and new locknuts (5).
2. Install clip (6) on bracket (1) and secure with screw (7), washer (8), and new locknut (9).
3. Position dropleaf rod (10) in bracket (1) and insert headless pin (11) through radio rack (2), dropleaf rod (10) and bracket (1). Secure with two washers (12) and new cotter pin (13).
4. Align two strikes (14) on table top (15). Secure with four key washers (16) and eight screws (17).
5. Install three hinges (18) on hull. Secure with six screws (19) and new locknuts (20).
6. Align three key washers (21) between hinges (18) and table top (15). Secure with six screws (22).

Lower table top (15) and secure two catches (23) on battery box to strikes (14).

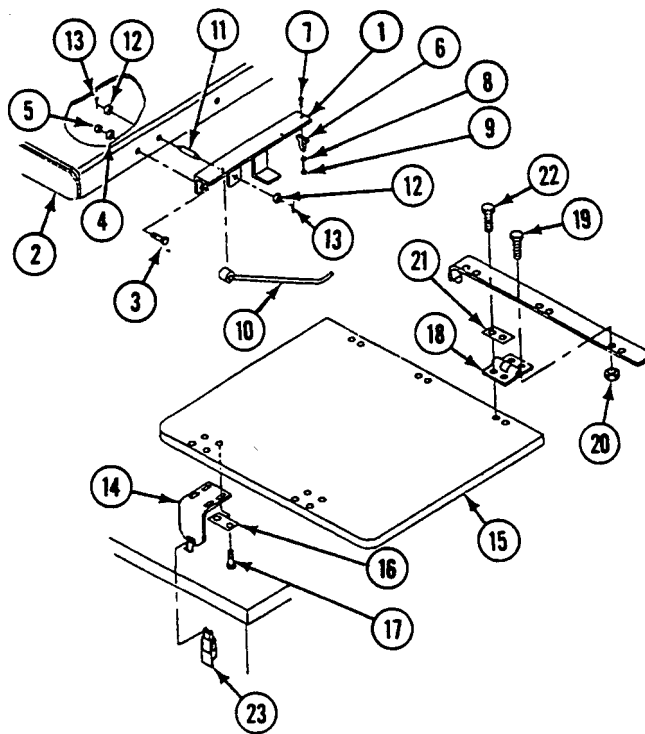
**FOLLOW-THROUGH STEPS**

1. Start engine (see your -10).
2. Raise and lock ramp (see your -10).
3. Stop engine (see your -10).

END OF TASK

REPLACE RIGHT REARWARD TABLE (M577A3 ONLY)

0582 00

THIS WORK PACKAGE COVERS:

Removal (page 0582 00-1).
 Installation (page 0582 00-2).

INITIAL SETUP:

Maintenance Level

Unit

Personnel Required

Unit Mechanic

Tools and Special Tools

General Mechanic's Tool Kit (WP 0926 00, Item 65)

References

See your -10

Materials/Parts

Locknut (12)
 Locknut (2)
 Lockwasher (8)

Equipment Condition

Engine stopped (see your -10)
 Carrier blocked (see your -10)
 Ramp lowered (see your -10)

REMOVAL

1. Remove sixteen screws (1), eight spacers (2), and two drop leaves (3) from table top (4).
2. Remove eight screws (5), lockwashers (6), and four catches (7) from two drop leaves (3). Discard lockwashers.
3. Remove three nuts (8), washers (9), screws (10), and table top (4) from hull.

NOTE

Shims (flat washers – two maximum) may be required to obtain clearance between screw and support bracket.

4. Remove two locknuts (11), washers (12), screws (13), four table supports (14), and shims (if installed) from hull. Discard locknuts.
5. Remove sixteen screws (15), eight spacers (16), hinges (17), and four supports (14) from table top (4).
6. Remove twelve locknuts (18), washers (19), screws (20), and four braces (21) from supports (14). Discard locknuts.

7. Remove four bumpers (22) from braces (21).

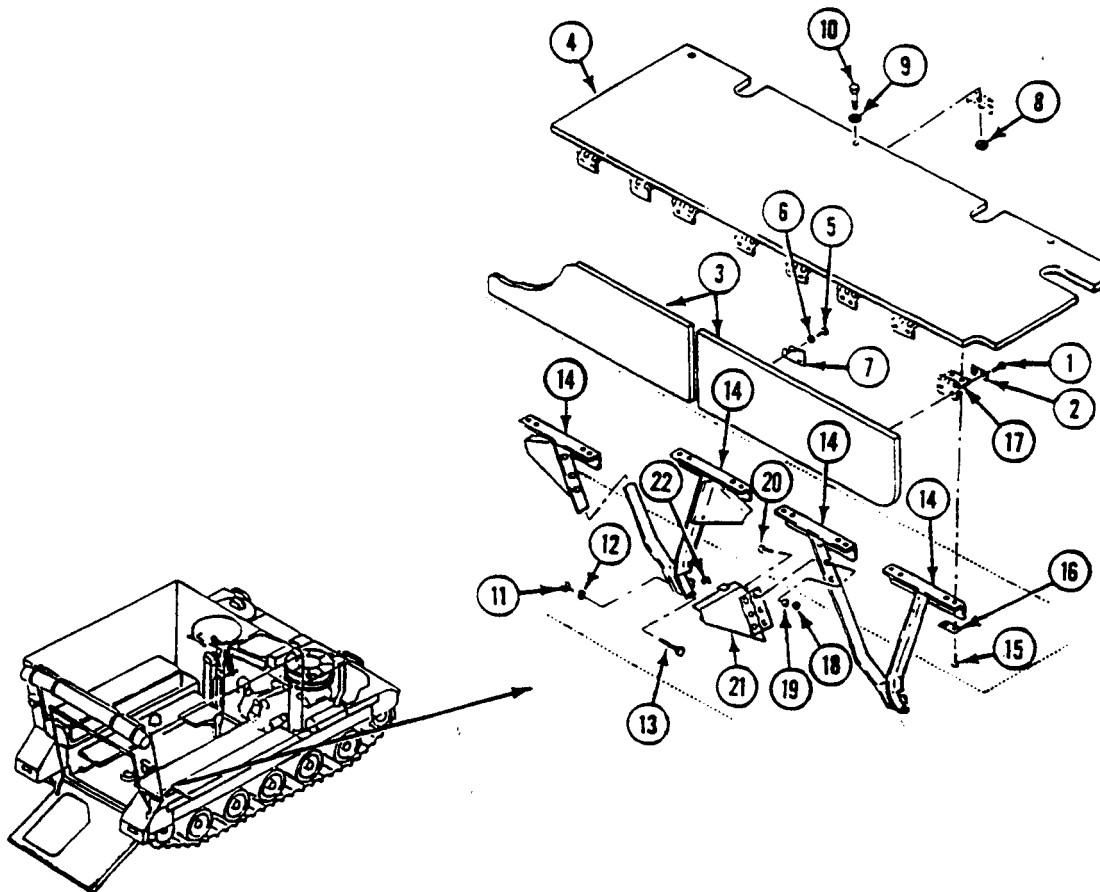

INSTALLATION

1. Install four bumpers (1) in braces (2).
2. Install four braces (2) on supports (3) and secure with twelve screws (4), washers (5), and new locknuts (6).
3. Align four supports (3) and hinges (7) on table top (8). Secure with eight spacers (9) and sixteen screws (10).

NOTE

Shims may be required to obtain clearance between screw and support bracket. Use flat washers as shims – two maximum.

4. Align table top (8) and supports (3) on hull. Secure with two screws (11), washers (12), and new locknuts (13).
5. Install three screws (14) through table top (8) and brackets on hull. Secure with three washers (15) and nuts (16).
6. Align four catches (17) on two drop leaves (18) and secure with eight new lockwashers (19) and screws (20).

7. Align two drop leaves (18) on hinges (7) and secure with eight spacers (21) and sixteen screws (22).

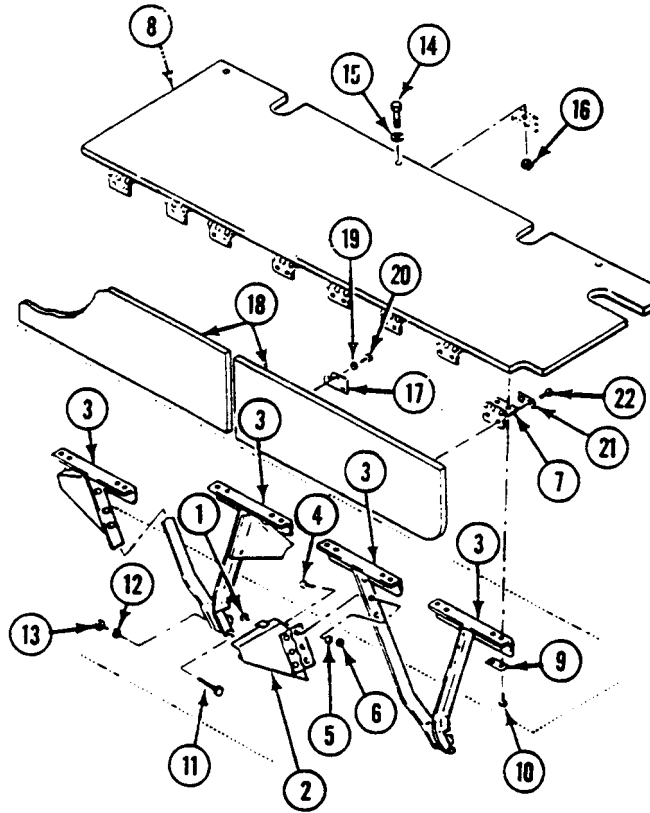
**FOLLOW-THROUGH STEPS**

1. Start engine (see your -10).
2. Raise and lock ramp (see your -10).
3. Stop engine (see your -10).

END OF TASK

**REPLACE/REPAIR RAMP VISION PORT AND SHIELD
(M58 ONLY)**

0586 00 ■

THIS WORK PACKAGE COVERS:

- Removal (page 0586 00-1).
 - Cleaning (page 0586 00-2).
 - Installation (page 0586 00-2).
-

INITIAL SETUP:

Maintenance Level

Unit

Personnel Required

Unit Mechanic

Tools and Special Tools

General Mechanic's Tool Kit (WP 0926 00, Item 65)

Materials/Parts

- Adhesive (WP 0928 00, Item 4)
- Adhesive (RTV) (WP 0928 00, Item 5)
- Grease (WP 0928 00, Item 12)
- Cleaning compound (WP 0928 00, Item 16)
- Cheesecloth (WP 0928 00, Item 20)
- Corrosion preventive compound (WP 0928 00, Item 24)
- Wiping rag (WP 0928 00, Item 65)
- Gasket
- Lockwasher (4)
- Packing (2)

References

- See your -10
- See your PMCS

Equipment Condition

- Engine stopped (see your -10)
 - Carrier blocked (see your -10)
 - Ramp raised (see your -10)
 - Rear access door open (see your -10)
-

REPLACE/REPAIR RAMP VISION PORT AND SHIELD (M58 ONLY) — Continued

0586 00

REMOVAL

1. Remove four screws (1) lockwashers (2), washers (3) and two mending plates (4) from housing (5). Discard lockwashers.
2. Remove four screws (6), washers (7) and shield (8) from ramp hatch (9).
3. Remove four screws (10), washers (11), housing (5), gasket (12), and vision block (13) from ramp hatch (9). Discard gasket.
4. Remove two screws (14), clamps (15), and shims (16) from ramp hatch (9).
5. Remove shaft (17), two spacers (18), and two springs (19) from shield (8).
6. Remove door (20) and two packings (21) from shield (8). Discard packings.

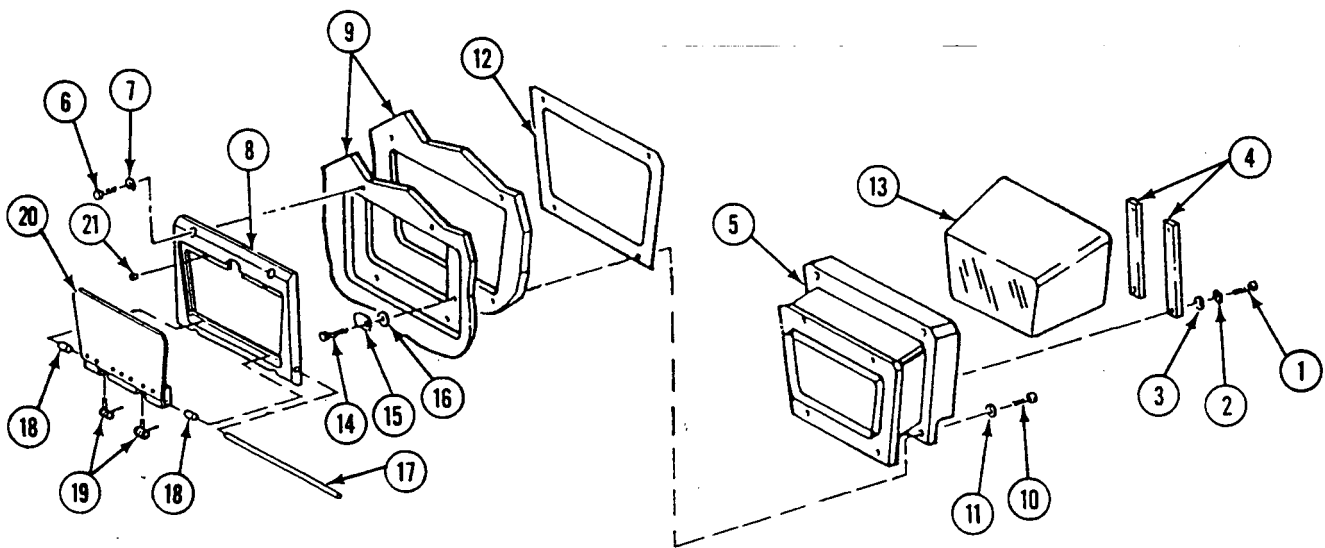
CLEANING

1. Apply cleaning compound or water to vision block (13). Use a clean wiping rag. Dry vision block with cheesecloth.

REPLACE/REPAIR RAMP VISION PORT AND SHIELD (M58 ONLY) — Continued

0586 00

INSTALLATION

1. Install two new packings (1) on shield (2) with adhesive.
2. Lubricate shaft (3) lightly with grease (WP 0155 00).
3. Install door (4), two spacers (5), two springs (6), and shaft (3) on shield (2).
4. Apply corrosion preventive compound to two screws (7).
5. Install two shims (8), clamps (9), and screws (7) on ramp hatch (10).
6. Apply RTV adhesive to inside of housing (12) as follows:
 - a. Apply three beads of RTV adhesive around inside walls of housing (12). Locate one bead in the center within ± 1.0 inch (2.54 cm) and one bead at each end of housing 1.0 ± 0.5 inch (2.54 ± 1.27 cm) from edge.
 - b. Apply RTV adhesive on outside edge between vision block and housing.
7. Install vision block (11) in housing (12).
8. Apply corrosion preventive compound to four screws (13).
9. Install new gasket (14) and housing (12) on ramp hatch (10). Secure with four washers (15) and screws (13).
10. Apply corrosion preventive compound to four screws (16).
11. Install shield (2) on ramp hatch (10). Secure with four washers (17) and screws (16).
12. Apply corrosion preventive compound to four screws (18).
13. Install two mending plates (19) on housing (12). Secure with four washers (20), new lockwashers (21), and screws (18).

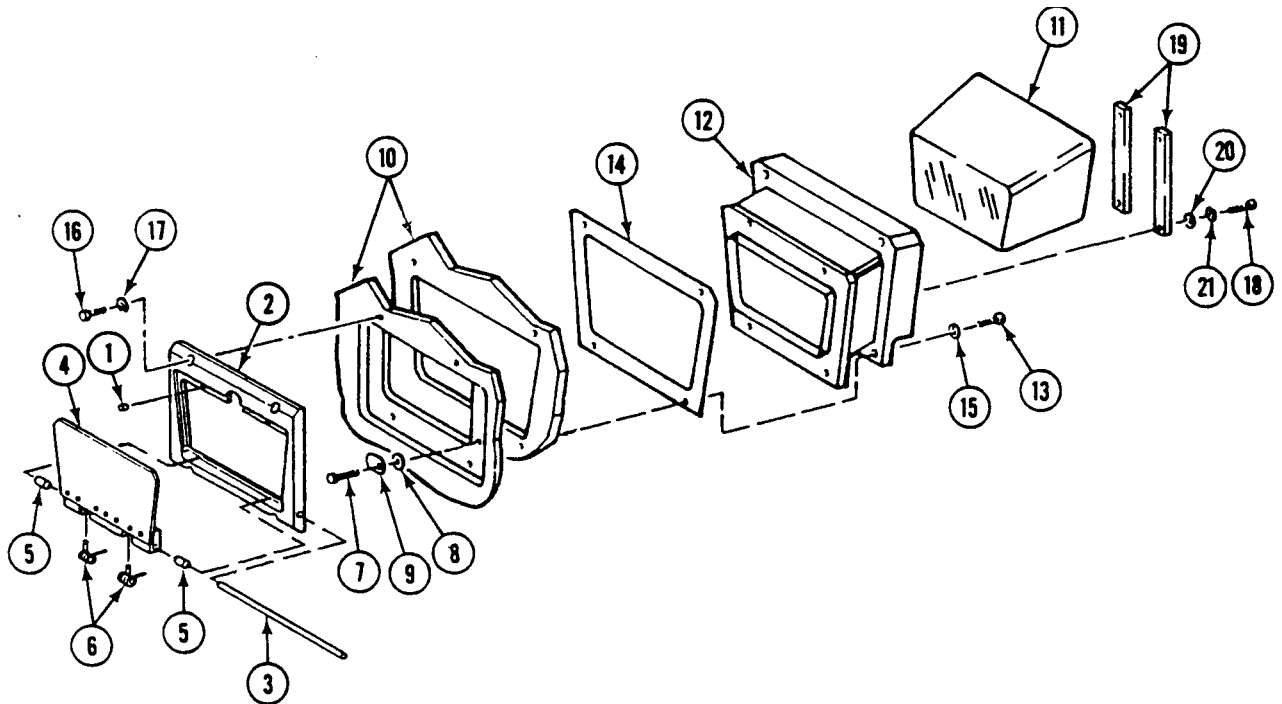

END OF TASK

REPLACE ANTENNA SUPPORT (M58 ONLY)

0602 00 ■

THIS WORK PACKAGE COVERS:

Removal (page 0602 00-1).
 Installation (page 0602 00-2).

INITIAL SETUP:

Maintenance Level

Unit

References

See your -10

Tools and Special Tools

General Mechanic's Tool Kit (WP 0926 00, Item 65)

Materials/Parts

Sealing compound (WP 0928 00, Item 53)

Grommet

Lockwasher (6)

Personnel Required

Unit Mechanic

Equipment Condition

Engine stopped (see your -10)

Carrier blocked (see your -10)

Ramp lowered (see your -10)

Antenna removed (WP 0887 00)

REMOVAL

1. Remove four screws (1), lockwashers (2), and washers (3). Discard lockwashers.
2. Remove two screws (4), lockwashers (5), washers (6), and remove support base. Discard lockwashers.
3. Remove and discard grommet (7).

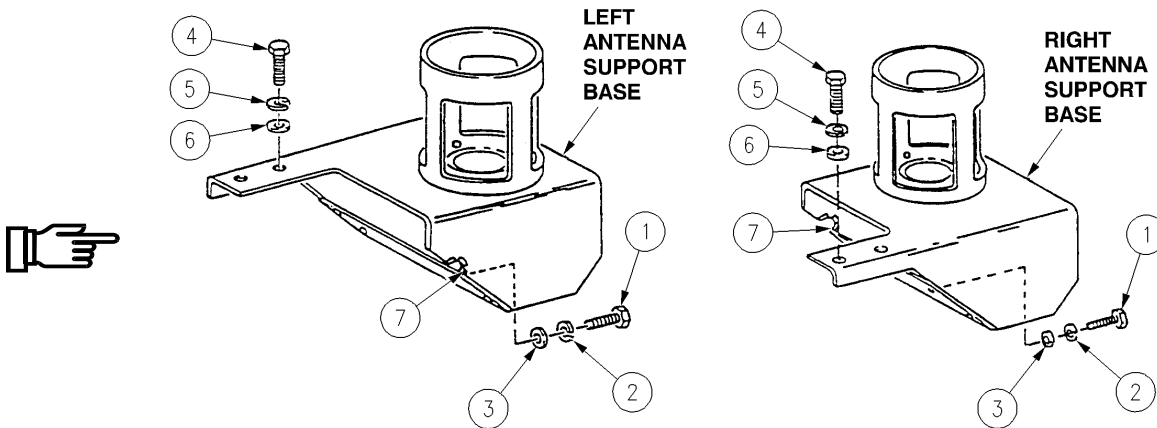
**INSTALLATION****NOTE**

Make sure primer and paint are removed around the grommet opening before applying sealing compound.

1. Apply sealing compound to grommet (7) and metal surface of antenna support base. Allow to dry until tacky.
2. Press new grommet (7) in place in grommet opening.
3. Place support base on vehicle and align screw holes.
4. Install two washers (6), new lockwashers (5), and screws (4).

5. Install four washers (3), new lockwashers (2), and screws (1).

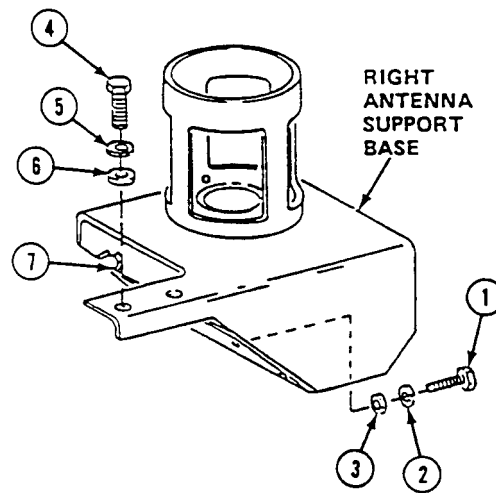
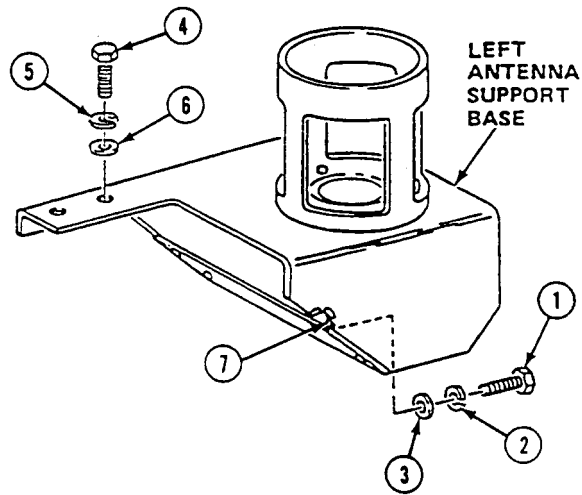

FOLLOW-THROUGH STEPS

1. Install antenna (WP 0887 00).
2. Start engine (see your -10).
3. Raise and lock ramp (see your -10).
4. Stop engine (see your -10).

END OF TASK

REPLACE CABLE REEL HOLDER ASSEMBLY (M1064A3 ONLY)

0603 00

THIS WORK PACKAGE COVERS:

Removal (page 0603 00-1).
 Installation (page 0603 00-3).

INITIAL SETUP:

Maintenance Level

Unit

Personnel Required

Unit Mechanic

Tools and Special Tools

General Mechanic's Tool Kit (WP 0926 00, Item 65)

References

See your -10

Materials/Parts

Lockwasher (2)

Equipment Condition

Engine stopped (see your -10)
 Carrier blocked (see your -10)

REMOVAL

NOTE

**The M1064A3 has only one holder - on the right external fuel tank.
 All holders are replaced the same way**

1. Remove two screws (1), lockwashers (2), and washers (3) securing holder assembly (4) to stop light-tail light guard (5) and external fuel tank (6). Discard lockwashers.
2. Remove holder assembly (4) from fuel tank.

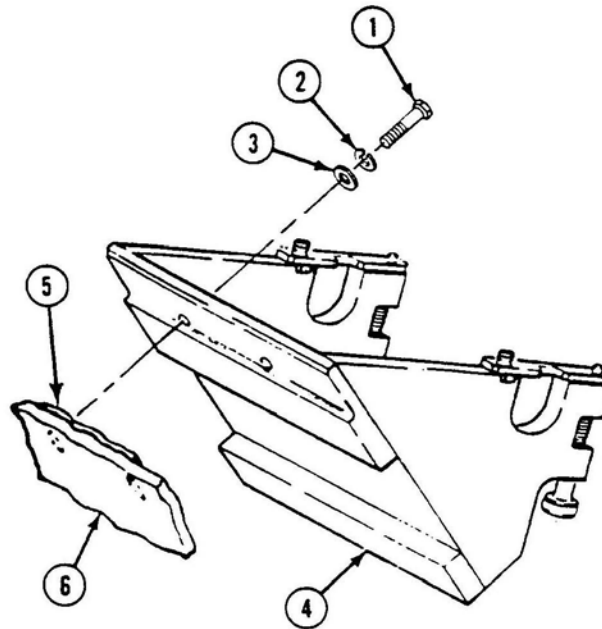

REPLACE CABLE REEL HOLDER ASSEMBLY (M1064A3 ONLY) —
Continued

0603 00

INSTALLATION

1. Install holder assembly (4) on fuel tank.
2. Secure holder assembly (4) to stop light-tail light guard (5) and external fuel tank (6) with two screws (1), new lockwashers (2), and washers (3).

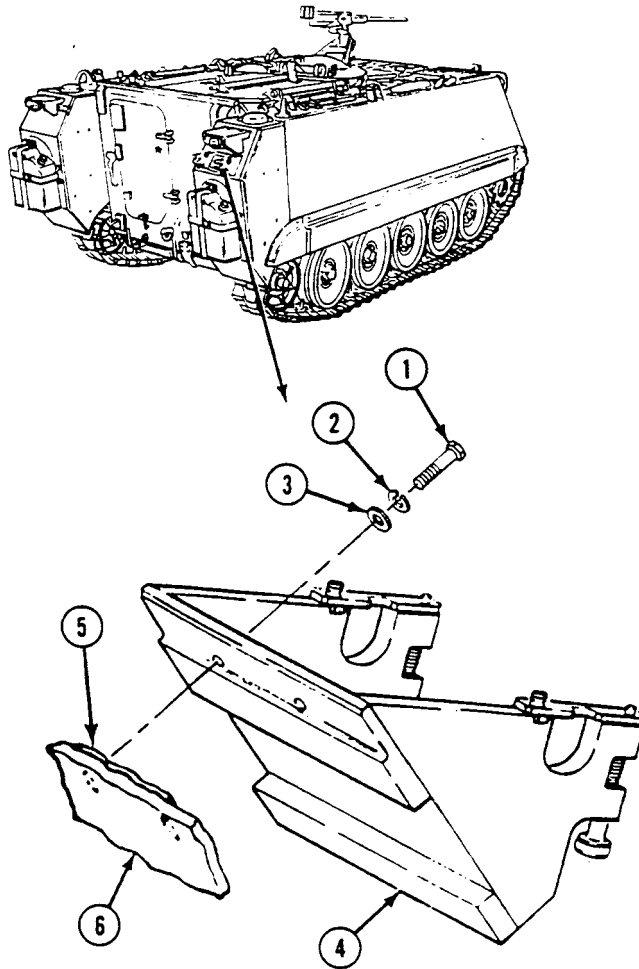
**END OF TASK**

REPAIR CABLE REEL HOLDER ASSEMBLY (M1064A3 ONLY)

0604 00

THIS WORK PACKAGE COVERS:

Disassembly (page 0604 00-1).
 Assembly (page 0604 00-3).

INITIAL SETUP:

Maintenance Level

Unit

References

See your -10

Tools and Special Tools

General Mechanic's Tool Kit (WP 0926 00, Item 65)

Materials/Parts

Cotter pin

Personnel Required

Unit Mechanic
 Helper

Equipment Condition

Engine stopped (see your -10)
 Carrier blocked (see your -10)
 Cable reel holder assembly removed (WP 0603 00)

DISASSEMBLY

1. Push pin (1) down and remove cotter pin (2), washer (3), and handle (4) from pin and cable reel holder (5). Discard cotter pin.
2. Remove pin (1), two washers (6), and spring (7) from cable reel holder.
3. Remove screw (8), washer (9), and retainer (10) from cable reel holder.

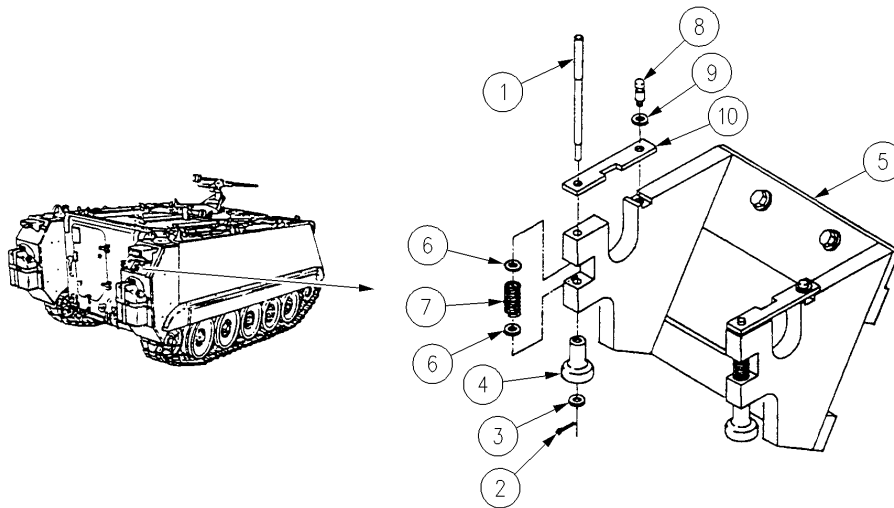

ASSEMBLY

1. Install retainer (10) on cable reel holder (5) with washer (9) and screw (8).
2. Install two washers (6), spring (7), and pin (1) in cable reel holder (5).
3. Push pin (1) down and attach handle (4) to pin with washer (3) and new cotter pin (2).

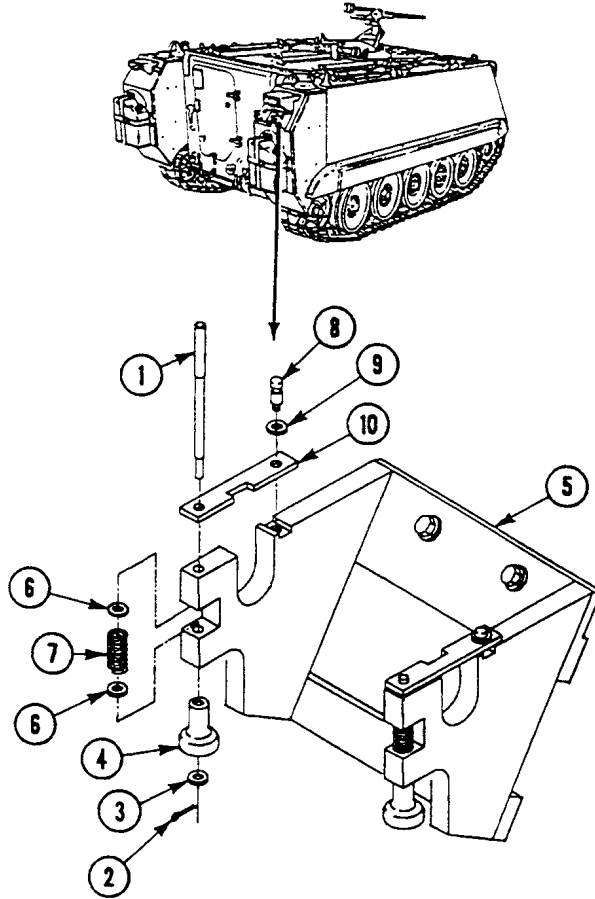
**FOLLOW-THROUGH STEPS**

1. Install cable reel holder assembly (WP 0603 00).

END OF TASK

REPLACE HORIZONTAL AMMUNITION RACK (M1064A3 ONLY)

0606 00

THIS WORK PACKAGE COVERS:

Removal (page 0606 00-1).
 Installation (page 0606 00-2).

INITIAL SETUP:

Maintenance Level

Unit

References

See your -10

Tools and Special Tools

General Mechanic's Tool Kit (WP 0926 00, Item 65)

Equipment Condition

Personnel Required

Unit Mechanic
 Helper

Engine stopped (see your -10)
 Carrier blocked (see your -10)
 Ramp lowered (see your -10)

REMOVAL

1. Remove four screws (1), washers (2), and two brackets (3) from hull top plate.
2. Remove 18 screws (4) and washers (5) from rack assembly (6) and side hull.
3. Remove two screws (7) and washers (8) from two vertical posts (9) and sponson.

WARNING



Rear trays of ammo rack could collapse when removed. To prevent injury, move ammo rack from the front. Keep fingers away from spaces between trays on the back of ammo rack.

4. Remove horizontal ammunition rack (6) from carrier.

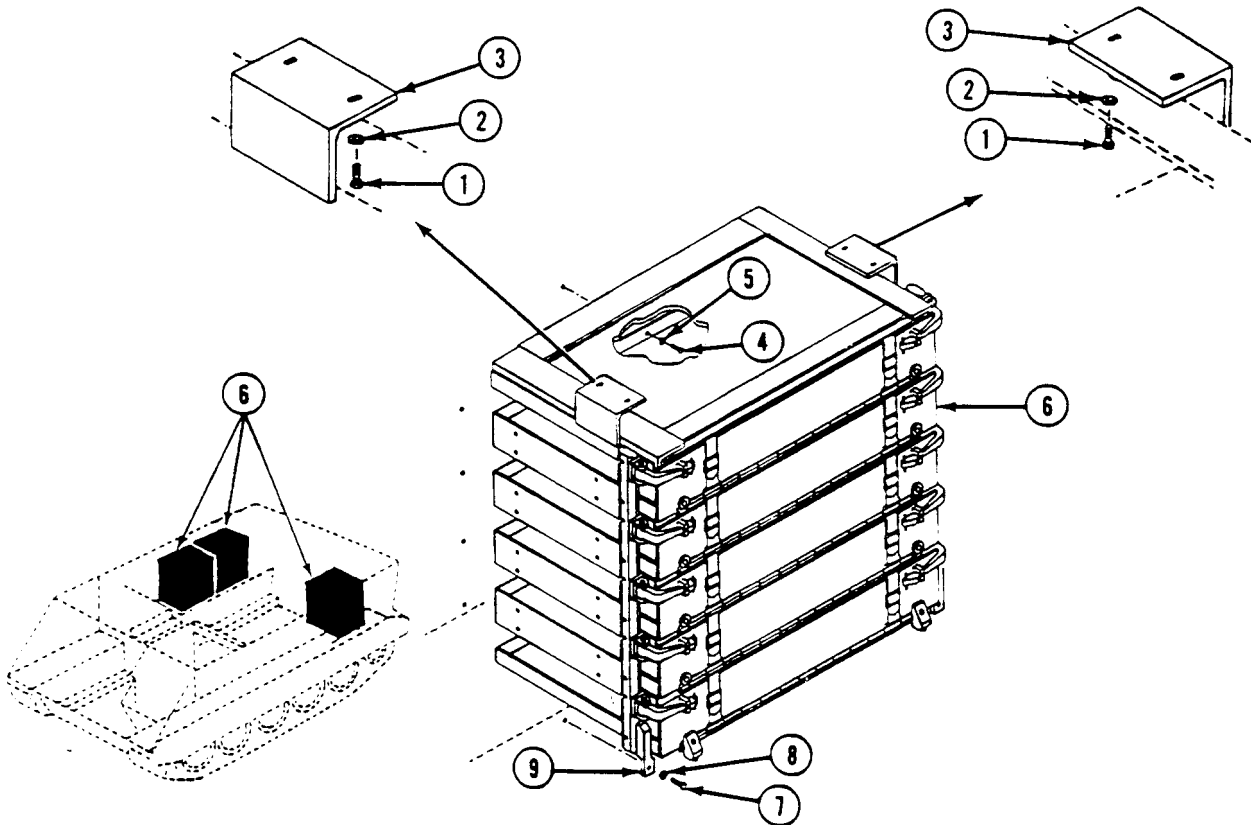

INSTALLATION

WARNING



Rear trays of ammo rack could collapse when removed. To prevent injury, move ammo rack from the front. Keep fingers away from spaces between trays on the back of ammo rack.

1. Position horizontal ammunition rack (1) on sponson. Jam rack against other rack, if installed.

- Install two screws (2), washers (3), vertical posts (4) on sponson.

NOTE

Start installation of 18 screws inside hull from top and work down. Rack mounting holes may be elongated to 3/16 inch to match hole pattern.

- Install 18 screws (5) and washers (6) in rack assembly (1) and side hull.
- Position two brackets (7) against hull top plate and top of rack (1). Install four screws (8) and washers (9) in brackets (7) and hull top plate. Close all ammo doors.

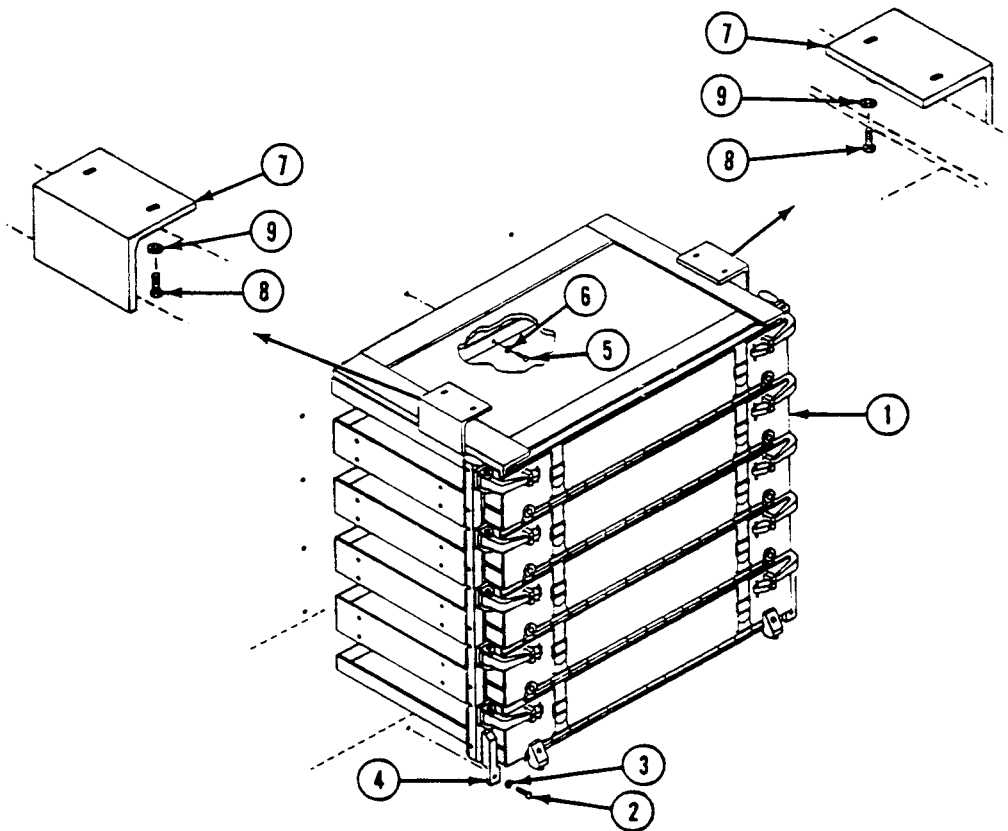

FOLLOW-THROUGH STEPS

- Start engine (see your -10).
- Raise and lock ramp (see your -10).
- Stop engine (see your -10).

END OF TASK

REPAIR HORIZONTAL AMMUNITION RACK (M1064A3 ONLY)

0607 00

THIS WORK PACKAGE COVERS:

- Disassembly (page 0607 00-1).
 - Cleaning (page 0607 00-4).
 - Inspection and Repair (page 0607 00-4).
 - Assembly (page 0607 00-4).
-

INITIAL SETUP:

Maintenance Level

Unit

Personnel Required

Unit Mechanic

Tools and Special Tools

- General Mechanic's Tool Kit (WP 0926 00, Item 65)
- Hand Blind Riveter (WP 0926 00, Item 44)

References

See your -10

Materials/Parts

- Adhesive (WP 0928 00, Item 7)
- Cleaning compound (WP 0928 00, Item 19)
- Rivet (20)

Equipment Condition

Horizontal ammo rack removed from carrier
(WP 0606 00)

DISASSEMBLY

1. Remove two webbing straps (1) from lower rack (2), and four middle racks (3).
2. Remove two screws (4), metallic bumpers (5) and four washers (6) from lugs on lower door (7).
3. Remove eight spacer bumpers (8) from four doors (9).
4. Release ten hooks (10) from five doors (7) and (9). Open doors.

5. Remove ten spring pins (11) and hooks (10) from vertical posts (12) and (13).

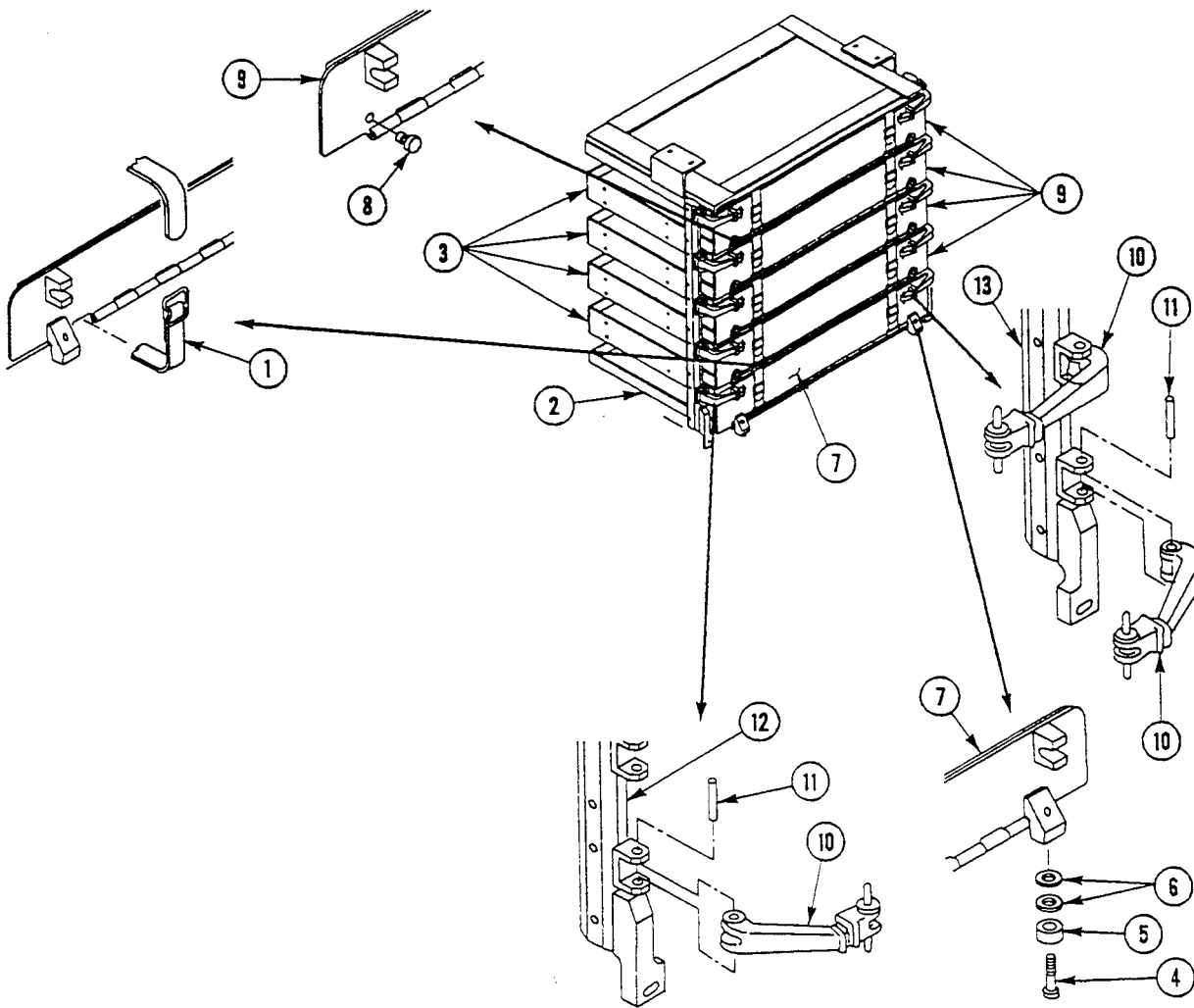

6. Remove four hinge pins (1) and doors (2) from four middle ammo racks (3).
7. Remove hinge pin (1) and door (4) from lower ammo rack (5).
8. Remove two screws (6), washers (7), shims (8), and upper stowage rack (9) from two vertical posts (10) and (11).
9. Remove two screws (6), washers (7), shims (12), and middle stowage rack (3) from two vertical posts (10) and (11).
10. Repeat Step 9 for four middle stowage racks (3).

11. Remove two screws (6), washers (7), shims (8), and lower stowage rack (5) from two vertical posts (10) and (11).
12. Remove four nuts (13), screws (16), washers (17) and two mortar wear bars (14) and (15) from each of five stowage racks (3)(5).

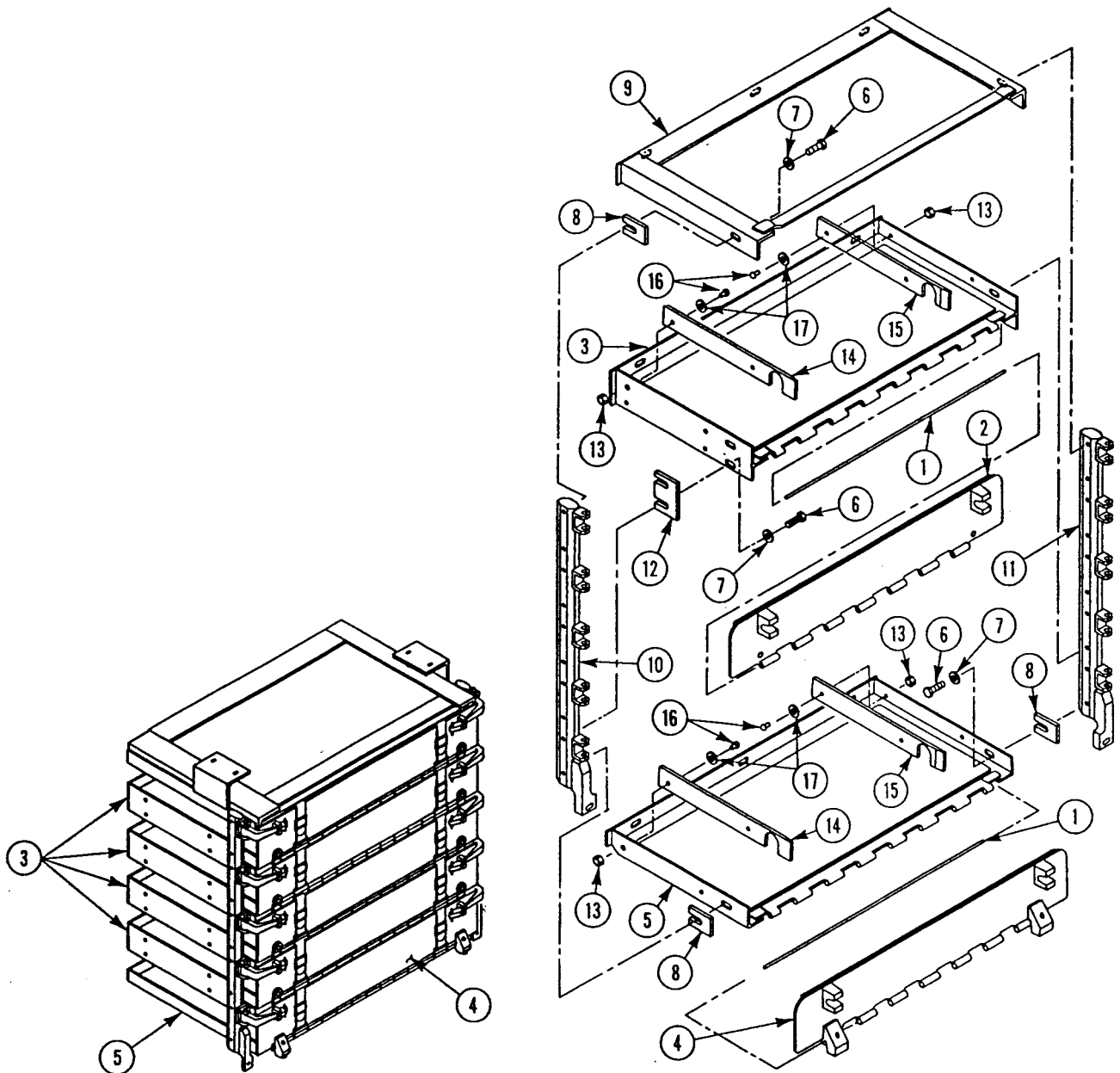

CLEANING

1. Clean all parts of stowage rack.

INSPECTION-ACCEPTANCE AND REJECTION CRITERIA

1. Inspect all metal parts for cracks, bends, or breaks. Repair minor defects. Replace parts that cannot be repaired.
2. Inspect webbing straps and door hooks for excessive wear, cuts, or fraying. Replace defective parts.

ASSEMBLY**NOTE**

Assemble each horizontal stowage rack without shims and straps outside the carrier. Do not tighten any mounting screws until after installation in the carrier.

1. Install two mortar wear bars (1) and (2) on lower stowage rack (3) with four washers (4), screws (14) and new nuts (15).
2. Install upper stowage rack (6) on vertical posts (7) and (8) with two washers (9) and screws (10).
3. Install lower stowage rack (3) on vertical posts (7) and (8) with two washers (9) and screws (10).
4. Install four middle stowage racks (5) on vertical posts (7) and (8) with 16 washers (9) and screws (10).
5. Install five doors (11) and (12) on five stowage racks (3) and (5) with five hinge pins (13).

6. Stake ends of five hinge pins (13) to five doors (11) and (12).

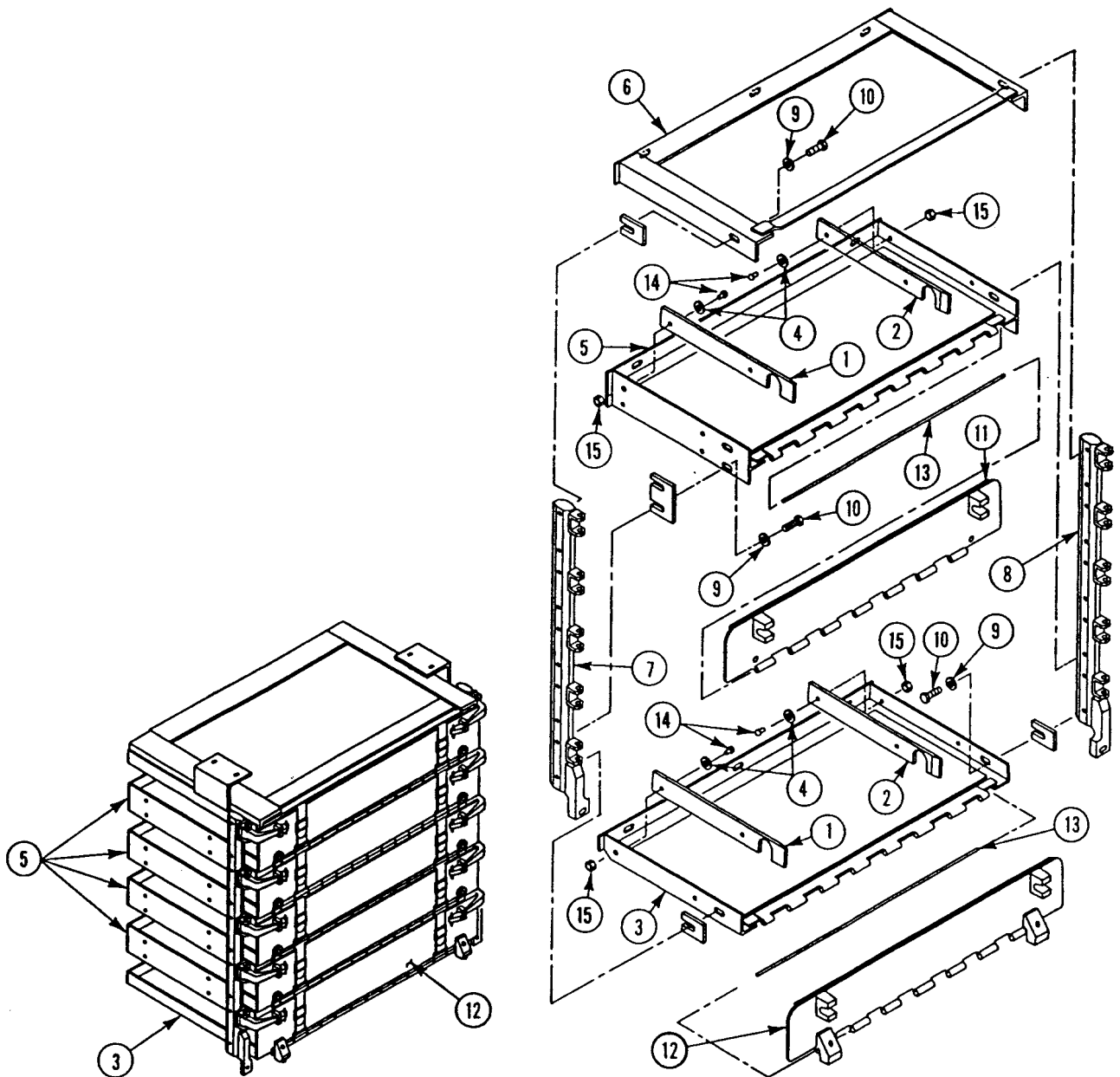

7. Install eight spacer bumpers (1) on four doors (2) as follows:
 - a. Clean mating surfaces on four doors (2) with cleaning compound.
 - b. Apply a thin even coat of adhesive to mating surfaces. Allow adhesive to dry until tacky (10 to 20 minutes). Press spacer bumpers firmly on doors (2).
8. Install ten hooks (3) on vertical posts (4) and (5) with ten spring pins (6).
9. Secure ten hooks (7) on five doors (2) and (8).
10. Install two metallic bumpers (9), four washers (10), and two screws (11) on lugs of lower door (8).

11. Install two mortar stowage webbing straps (12) in bottom slots of five doors (2) and (8). Secure each strap around door.

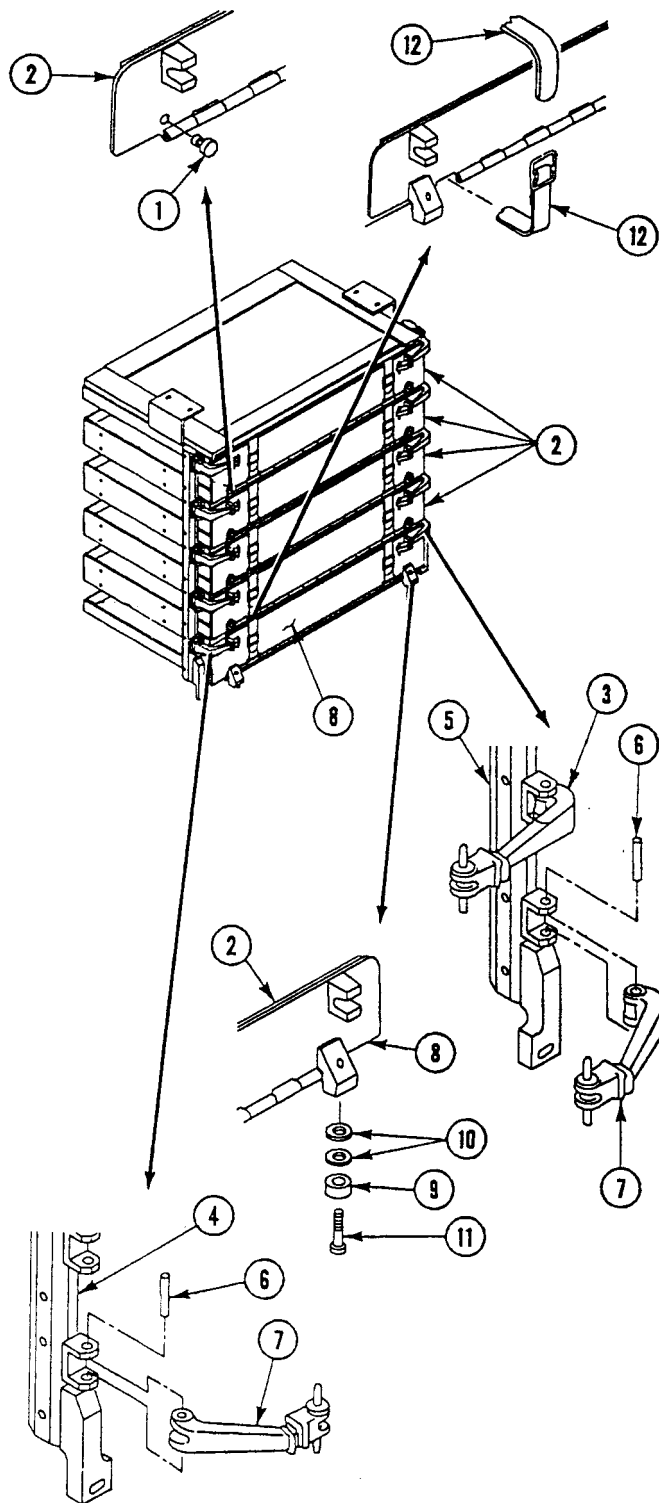

FOLLOW-THROUGH STEPS

1. Install horizontal ammo rack (WP 0606 00).

END OF TASK

REPLACE VERTICAL AMMUNITION RACK (M1064A3 ONLY)

0608 00

THIS WORK PACKAGE COVERS:

Removal (page 0608 00-1).
 Installation (page 0608 00-3).

INITIAL SETUP:

Maintenance Level

Unit

References

See your -10

Tools and Special Tools

General Mechanic's Tool Kit (WP 0926 00, Item 65)

Equipment Condition

Engine stopped (see your -10)

Personnel Required

Unit Mechanic

Carrier blocked (see your -10)

Ramp lowered (see your -10)

REMOVAL

NOTE

Vertical ammunition racks in the M1064A3 carrier are replaced the same way. Racks differ in size and capacity.

1. Remove twelve screws (1), washers (2), and rack (3) from side hull and top plate.
2. Remove eleven screws (4), washers (5), and rack (6) from side hull and sponson.
3. If damaged, remove ten straps (7) from loops (8) on left side hull.
4. If damaged, remove two straps (9) from loops (10) on sponson side plate.
5. If damaged, remove two decals (11) from sponson side plate.
6. If damaged, remove decal (12) from sponson side plate.

7. If damaged, remove strap (13) from loops (14) on sponson side plate.

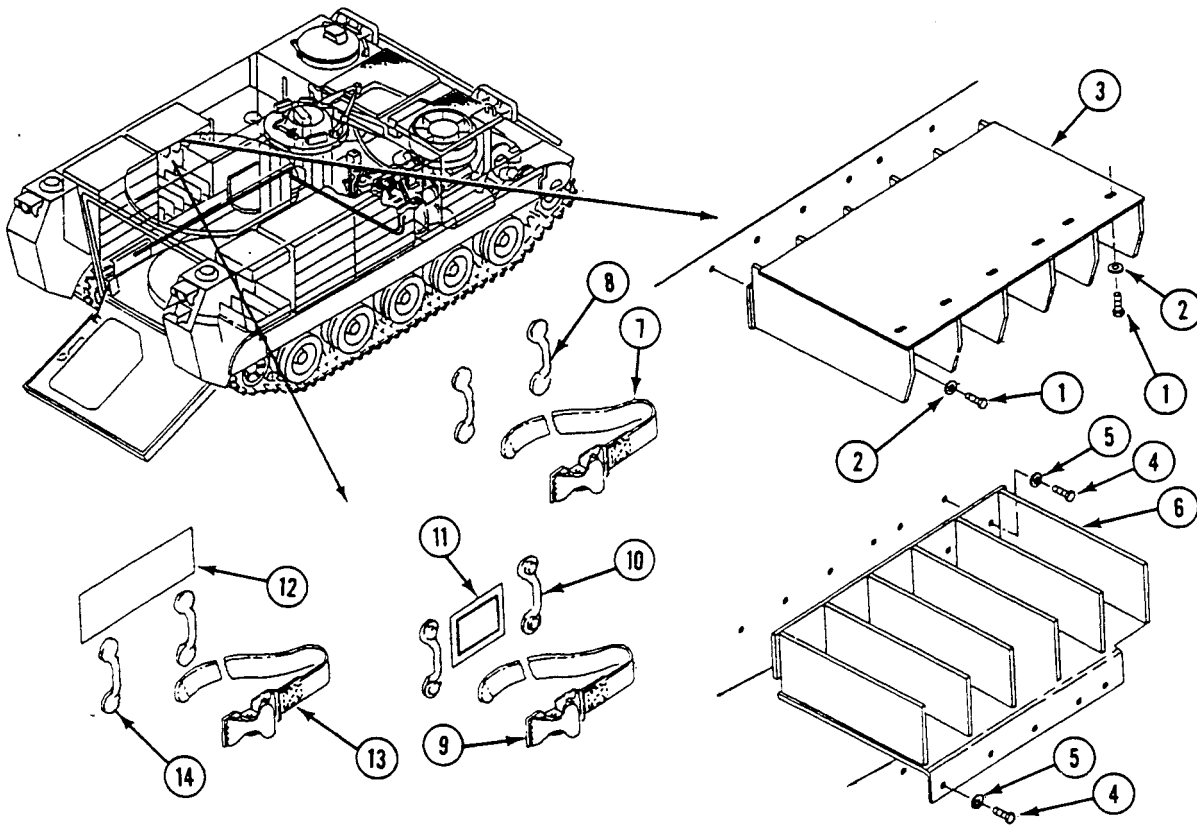

INSTALLATION

1. If straps (1), (2), or (3) were removed, replace with new straps.
2. If decals (4) or (5) were removed, clean area and apply new decal.
3. Install rack (6), eleven washers (7), and screws (8) on side hull and sponson.
4. Install rack (9), twelve washers (10), and screws (11) on side hull and top plate.

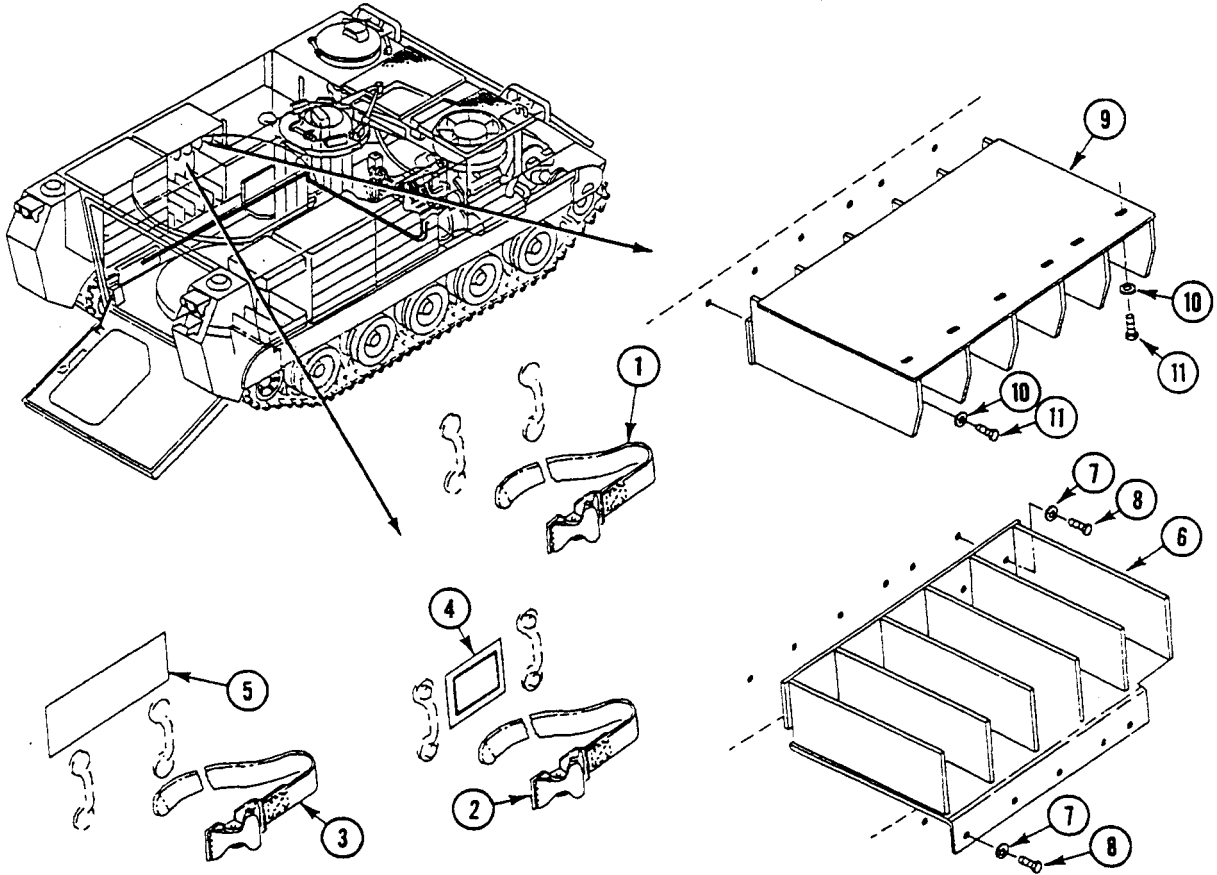

FOLLOW-THROUGH STEPS

1. Start engine (see your -10).
2. Raise and lock ramp (see your -10).
3. Stop engine (see your -10).

END OF TASK

REPLACE RADIO STOWAGE RACK (M1064A3 ONLY)

0609 00

THIS WORK PACKAGE COVERS:

- Removal (page 0609 00-1).
- Installation (page 0609 00-1).

INITIAL SETUP:

Maintenance Level
Unit

References
See your -10

Tools and Special Tools
General Mechanic's Tool Kit (WP 0926 00, Item 65)

Equipment Condition

Materials/Parts
Locknut (8)
Lockwasher (13)

- Engine stopped (see your -10)
- Carrier blocked (see your -10)
- Ramp lowered (see your -10)
- Radio and mount removed (WP 0890 00)

Personnel Required
Unit Mechanic

REMOVAL

1. Remove locknut (1), lockwasher (2), washer (3), hanger (4), and screw (5) from top plate crossmember. Discard locknut and lockwasher.
2. Remove locknut (6), two lockwashers (7), hanger (8), and screw (9) from top plate lug. Discard locknut and lockwashers.
3. Remove two locknuts (10), four lockwashers (11), two hangers (4)(8), and two screws (12) from rack (13). Discard locknuts and lockwashers.
4. Remove four locknuts (14), eight lockwashers (15), four screws (16), and rack (13) from bulkhead lugs. Discard locknuts and lockwashers.

INSTALLATION

1. Align rack (13) with bulkhead lugs. Secure with four screws (16), eight new lockwashers (15), and four new locknuts (14).
2. Align two hangers (4)(8) with rack (13). Secure with two screws (12), four new lockwashers (11), and two new locknuts (10).
3. Align hanger (8) with top plate lug. Secure with screw (9), two new lockwashers (7), and new locknut (6).
4. Align hanger (4) with top plate crossmember. Secure with screw (5), new lockwasher (2), washer (3), and new locknut (1).

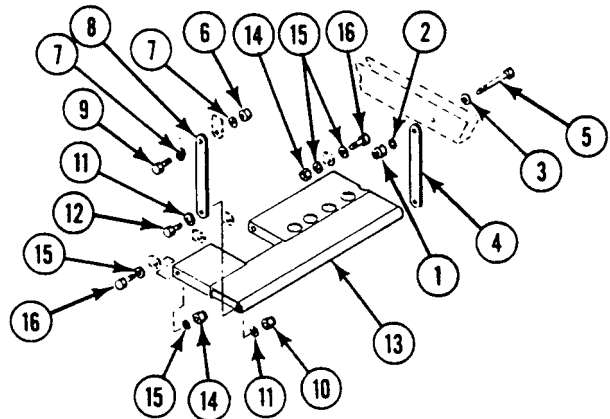
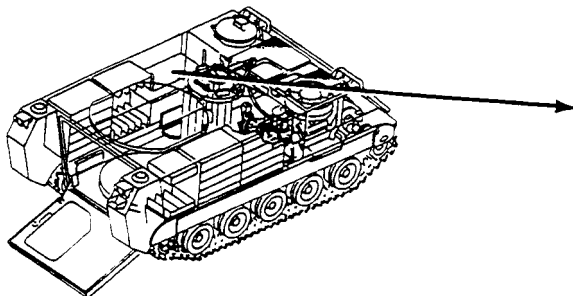

FOLLOW-THROUGH STEPS

1. Install radio and mount (WP 0890 00).
2. Start engine (see your -10).
3. Raise and lock ramp (see your -10).
4. Stop engine (see your -10).

END OF TASK

REPLACE GRENADE STOWAGE BOX (M1064A3 ONLY)

0610 00

THIS WORK PACKAGE COVERS:

Removal (page 0610 00-1).
 Installation (page 0610 00-1).

INITIAL SETUP:

Maintenance Level

Unit

Personnel Required

Unit Mechanic

Tools and Special Tools

General Mechanic's Tool Kit (WP 0926 00, Item 65)

References

See your -10

Materials/Parts

Locknut (6)

Equipment Condition

Engine stopped (see your -10)
 Carrier blocked (see your -10)

REMOVAL

1. Remove six locknuts (1), washers (2), screws (3), and two grenade stowage boxes (4) from sponson mounts. Discard locknuts.

INSTALLATION

1. Align two grenade stowage boxes (4) with sponson mounts. Secure with six screws (3), washers (2), and new locknuts (1).

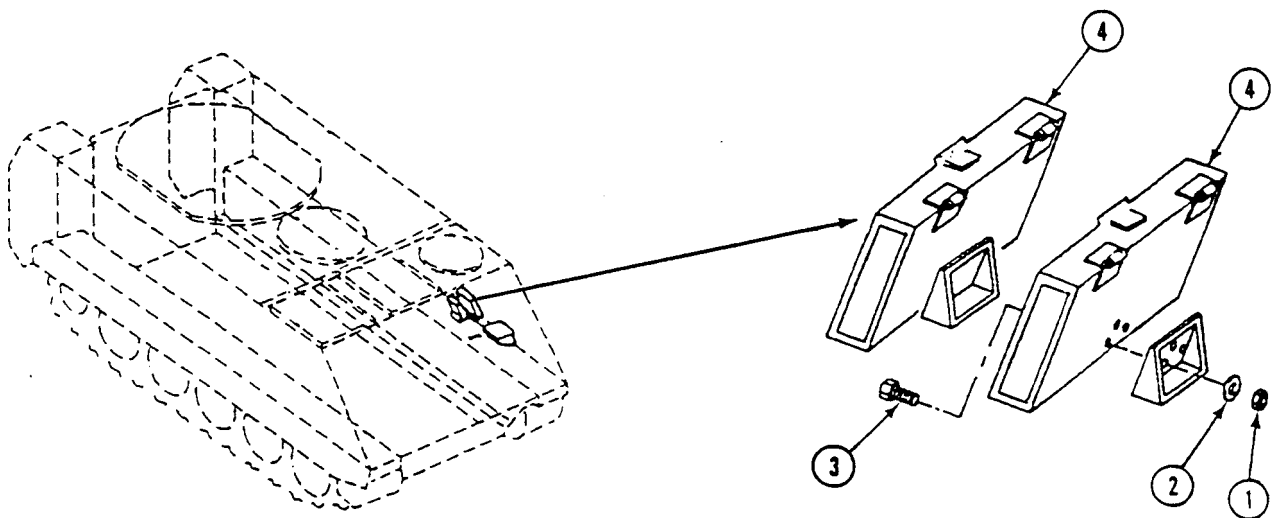

END OF TASK

REPLACE PERISCOPE STOWAGE BOX (M1064A3 ONLY)

0611 00

THIS WORK PACKAGE COVERS:

Removal (page 0611 00-1).
 Installation (page 0611 00-2).

INITIAL SETUP:

Maintenance Level

Unit

Personnel Required

Unit Mechanic

Tools and Special Tools

General Mechanic's Tool Kit (WP 0926 00, Item 65)

References

See your -10

Materials/Parts

Locknut (4)

Equipment Condition

Engine stopped (see your -10)
 Carrier blocked (see your -10)
 Ramp lowered (see your -10)

REMOVAL

1. Remove four screws (1), washers (2), locknuts (3) and periscope stowage box (4) from bracket (5) on sponson. Discard locknuts.

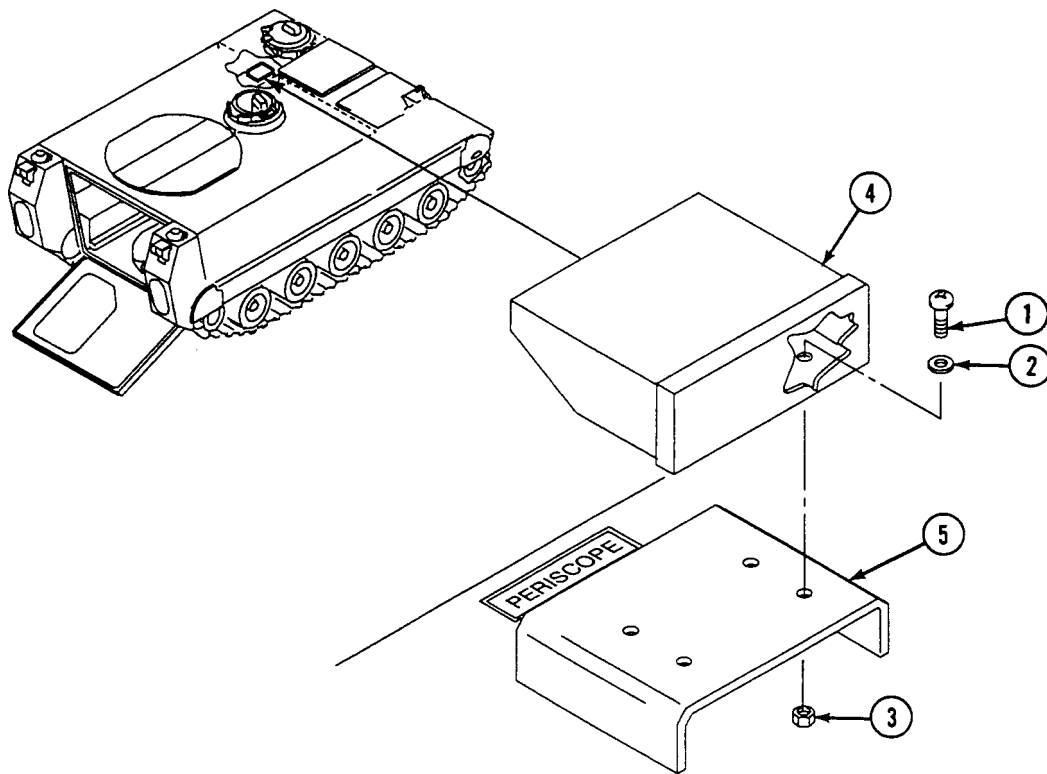

INSTALLATION

1. Align periscope stowage box (4) with hole on welded bracket (5) on sponson. Secure with four screws (1), washers (2), and new locknuts (3).

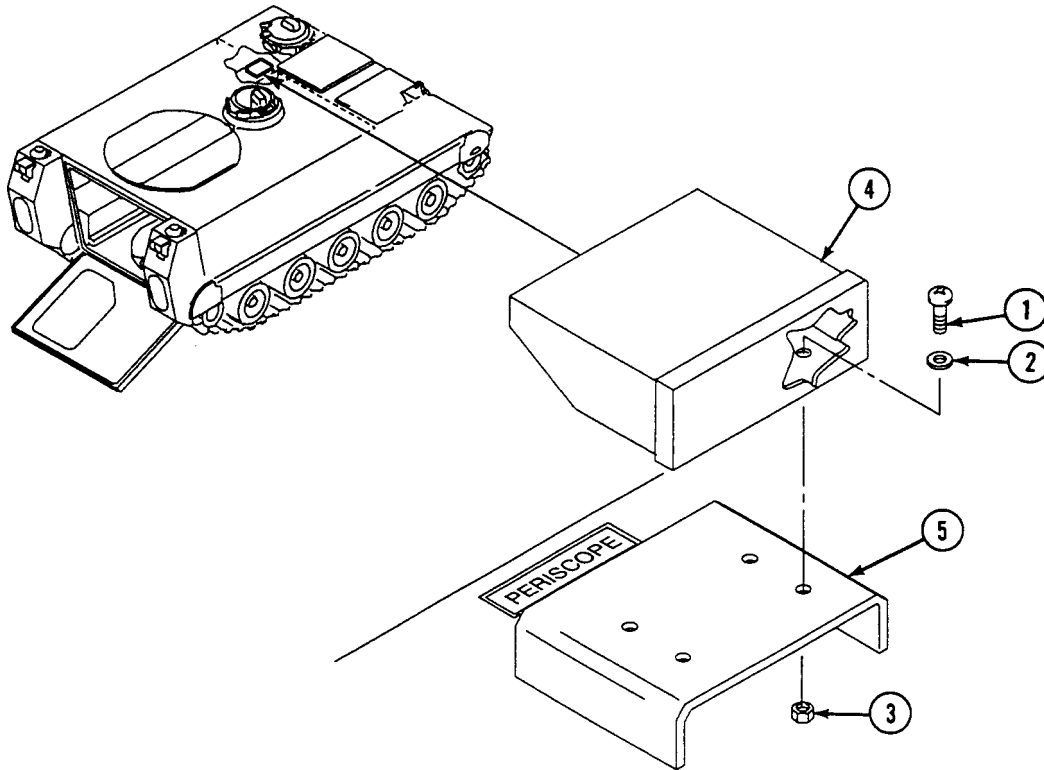
**FOLLOW-THROUGH STEPS**

1. Raise and lock ramp (see your -10).
2. Stop engine (see your -10).

END OF TASK

REPLACE RIFLE RACK (M1064A3 ONLY)

0612 00

THIS WORK PACKAGE COVERS:

Removal (page 0612 00-1).
 Installation (page 0612 00-2).

INITIAL SETUP:

Maintenance Level

Unit

References

See your -10

Tools and Special Tools

General Mechanic's Tool Kit (WP 0926 00, Item 65)

Equipment Condition

Engine stopped (see your -10)
 Carrier blocked (see your -10)
 Sight extension arm stowage brackets removed
 (WP 0613 00)
 Rifle brackets removed (WP 0573 00)

Materials/Parts

Locknut (2)

Personnel Required

Unit Mechanic

REMOVAL

1. Remove screw (1), locknut (2), and two washers (3) from rifle rack (4) and commander's seat post (5). Discard locknut.
2. Remove screw (6), locknut (7), and two washers (8) from rifle rack (4) and commander's seat post (5). Discard locknut.

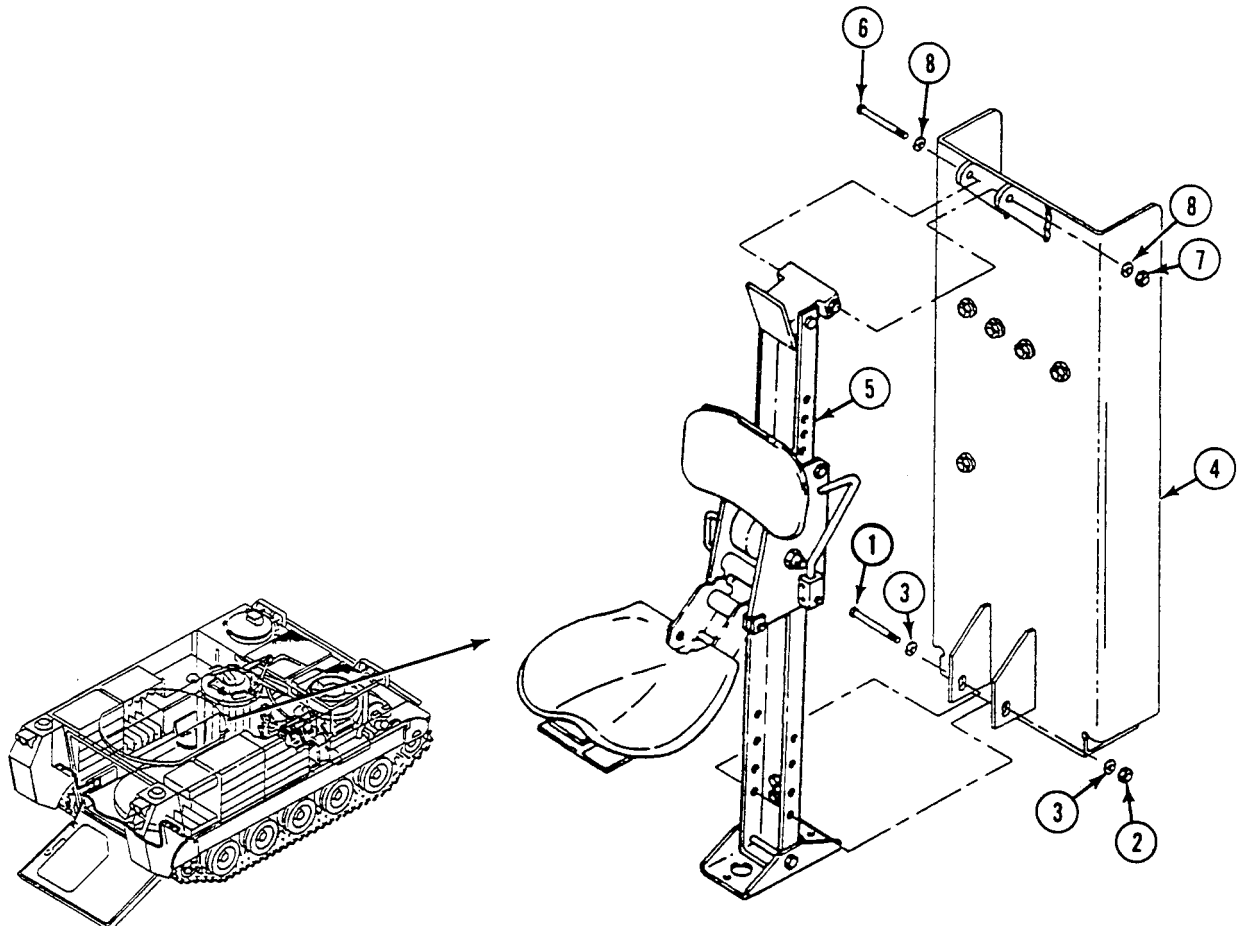

INSTALLATION

1. Position rifle rack (4) on commander's seat post (5) and secure with screw (6), two washers (8), and new locknut (7).
2. Secure base of rifle rack (4) with screw (1), two washers (3), and new locknut (2).

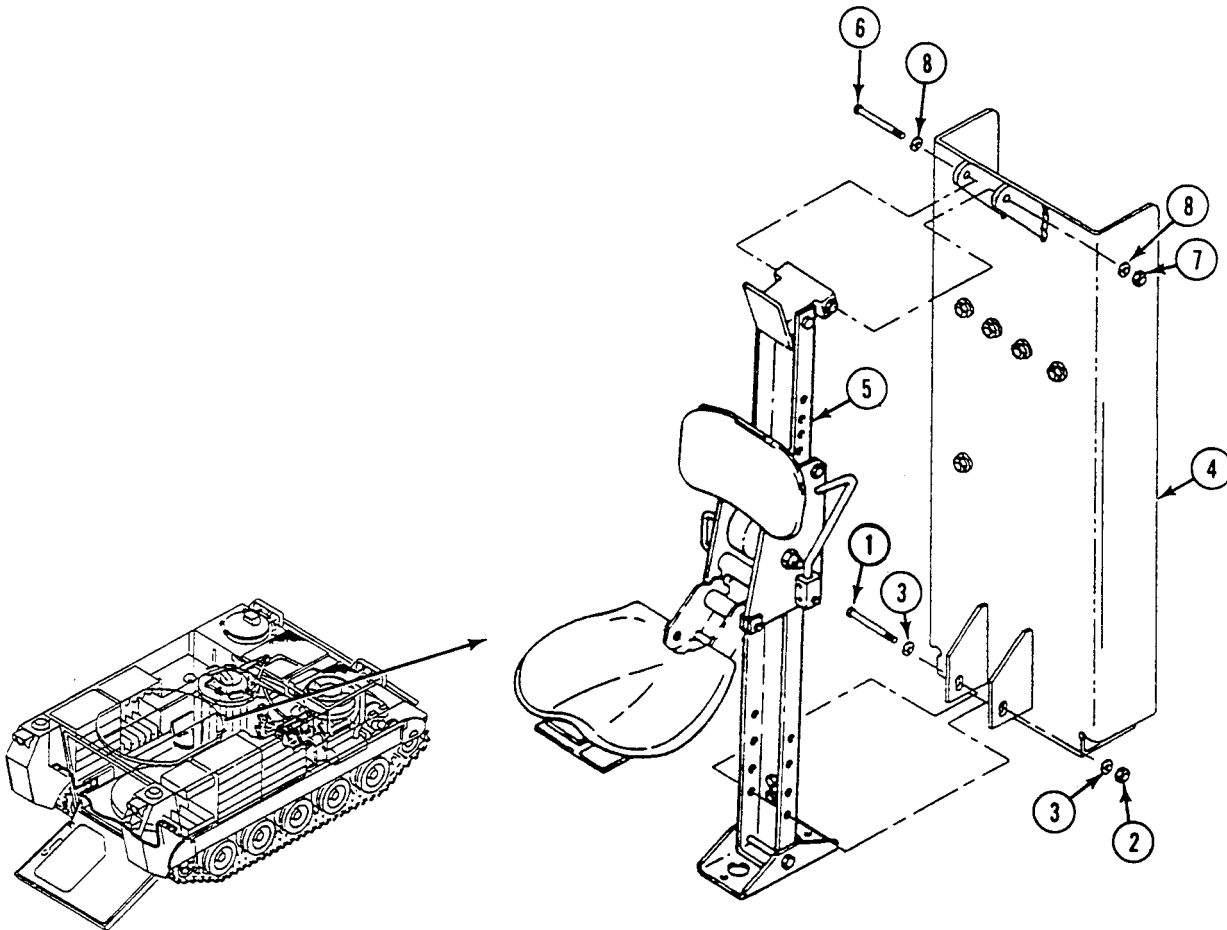
**FOLLOW-THROUGH STEPS**

1. Install rifle brackets (WP 0573 00).
2. Install sight extension arm stowage brackets (WP 0613 00).

END OF TASK

REPLACE SIGHT EXTENSION ARM STOWAGE BRACKETS (M1064A3 ONLY)

0613 00

THIS WORK PACKAGE COVERS:

Removal (page 0613 00-1).
 Installation (page 0613 00-2).

INITIAL SETUP:

Maintenance Level

Unit

Personnel Required

Unit Mechanic

Tools and Special Tools

General Mechanic's Tool Kit (WP 0926 00, Item 65)

References

See your -10

Materials/Parts

Locknut (6)

Equipment Condition

Engine stopped (see your -10)
 Carrier blocked (see your -10)
 Ramp lowered (see your -10)

REMOVAL

1. Remove two screws (1), locknuts (2), four washers (3), and two brackets (4) and (5) from rifle rack (6). Discard locknuts.
2. Remove two screws (7), locknuts (8), four washers (9), and bracket (10) from rifle rack (6). Discard locknuts.
3. Remove two locknuts (11), two screws (12), four washers (13), and bracket (14) from rifle rack (6). Discard locknuts.

REPLACE SIGHT EXTENSION ARM STOWAGE BRACKETS (M1064A3 ONLY) —
Continued

0613 00

INSTALLATION

1. Install bracket (14) on rifle rack (6) with two screws (12), four washers (13), and two new locknuts (11).
2. Install bracket (10) on rifle rack (6) with two screws (7), four washers (9), and two new locknuts (8).
3. Align two brackets (4) and (5) with rifle rack (6). Secure with two screws (1), four washers (3), and two new locknuts (2).

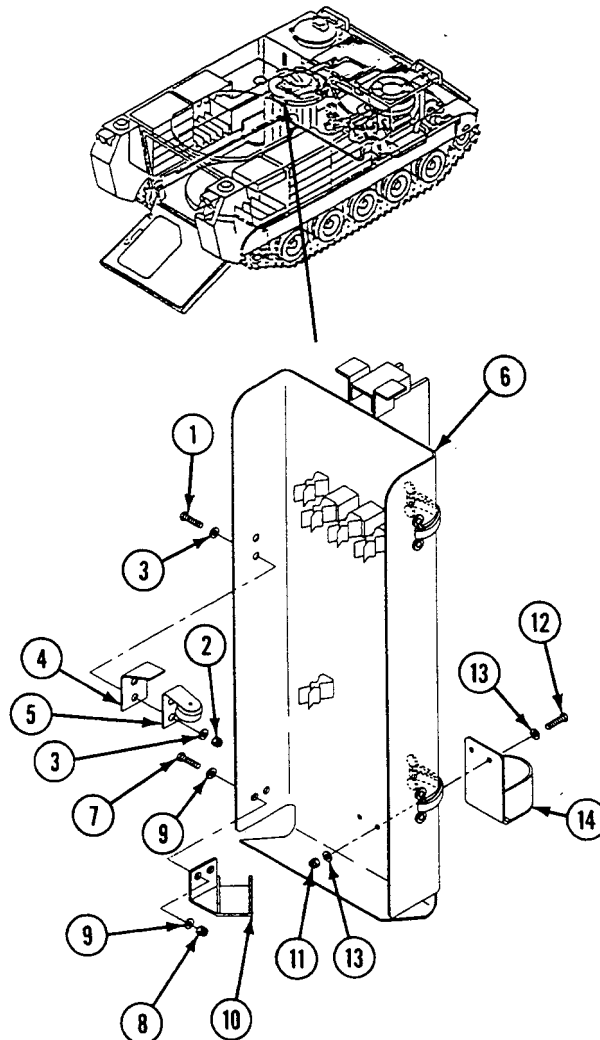
**FOLLOW-THROUGH STEPS**

1. Start engine (see your -10).
2. Raise and lock ramp (see your -10).
3. Stop engine (see your -10).

END OF TASK

REPLACE WINDSHIELD STOWAGE BRACKET (M1064A3 ONLY)

0614 00

THIS WORK PACKAGE COVERS:

Removal (page 0614 00-1).
 Installation (page 0614 00-2).

INITIAL SETUP:

Maintenance Level

Unit

Personnel Required

Unit Mechanic

Tools and Special Tools

General Mechanic's Tool Kit (WP 0926 00, Item 65)

References

See your -10

Materials/Parts

Adhesive (WP 0928 00, Item 3)

Cotter Pin

Equipment Condition

Engine stopped (see your -10)

Carrier blocked (see your -10)

REMOVAL

1. Remove four screws (1), washers (2), bracket (3), and retainer (4) from rear bulkhead.
 2. Remove cotter pin (5), from pin (6) and strap (7) from bulkhead bracket. Discard cotter pin.
- If needed, remove pads (8) from retainer (4) and pads (9)(10)(11) from bracket (3).

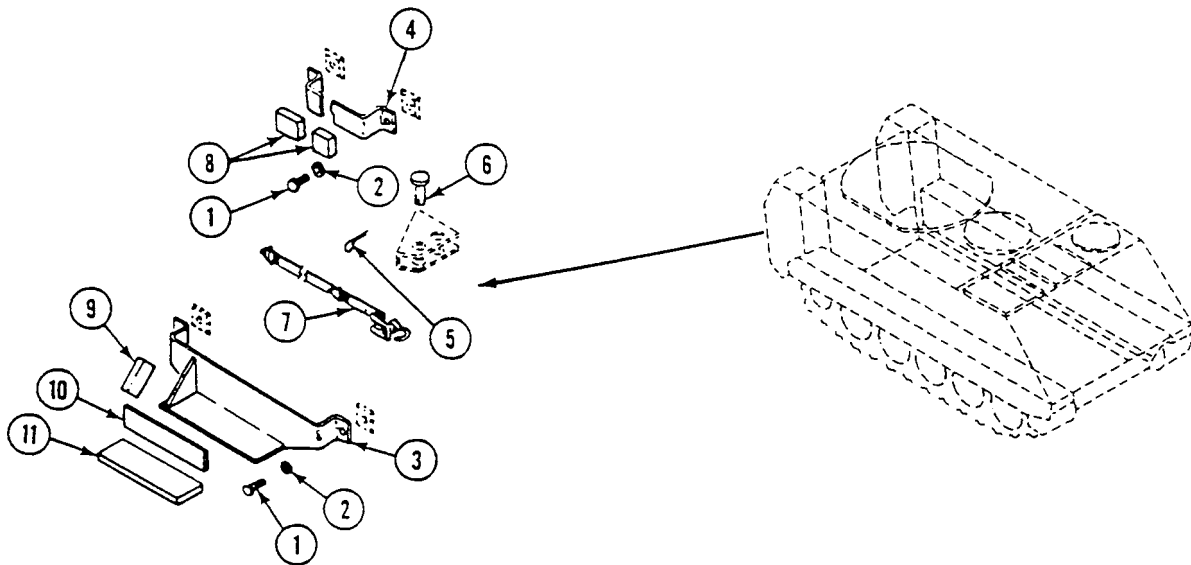

INSTALLATION

1. If removed, apply thin coat of adhesive to pads (9)(10)(11) and bracket (3) or pads (8) and retainer (4). Press pads firmly in place on mounting surface.
2. Place strap (7) on bulkhead bracket. Secure with pin (6) and new cotter pin (5).
Align retainer (4) and bracket (3) on rear bulkhead. Secure with four washers (2) and screws (1).

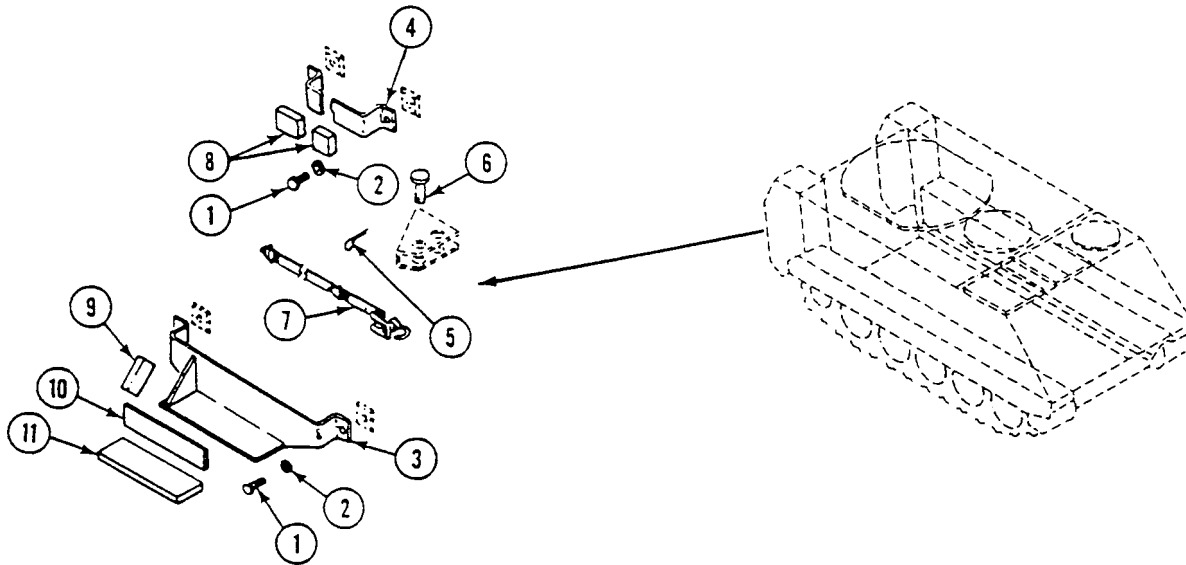
**END OF TASK**

REPLACE MORTAR BASE STOWAGE BRACKET (M1064A3 ONLY)

0615 00

THIS WORK PACKAGE COVERS:

- Removal (page 0615 00-1).
- Installation (page 0615 00-3).

INITIAL SETUP:

Maintenance Level

Unit

References

See your -10
TM 9-1015-250-10

Tools and Special Tools

General Mechanic's Tool Kit (WP 0926 00, Item 65)

Equipment Condition

Engine stopped (see your -10)
Carrier blocked (see your -10)
Mortar base removed (see TM 9-1015-250-10)

Personnel Required

Unit Mechanic

REMOVAL

1. Remove three screws (1), lock washers (2), and mounting bracket (3) from exterior bulkhead. Discard lock washers.
2. Remove four screws (4), washers (5), lock washer (6) and mounting bracket (7) from exterior bulkhead. Discard lock washers.

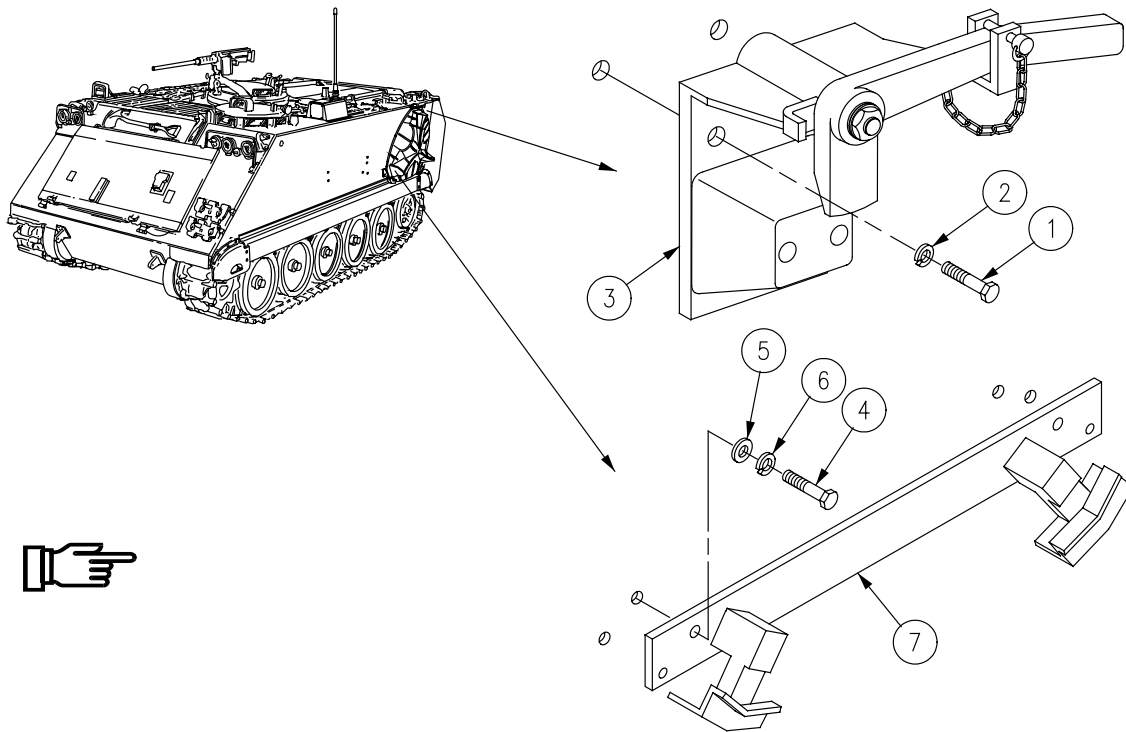

REPLACE MORTAR BASE STOWAGE BRACKET (M1064A3 ONLY) — Continued

0615 00

3. Remove locking pin assembly (7.1), from mounting bracket (3).
4. Remove two screws (8), flat washers (9), rubber bumper (10), and three spacers (11) from mounting bracket (3).
5. Remove lock nut (12), lock washer (13), flat washer (14), and control handle (15) from mounting bracket (3). Discard lock nut and lock washer.

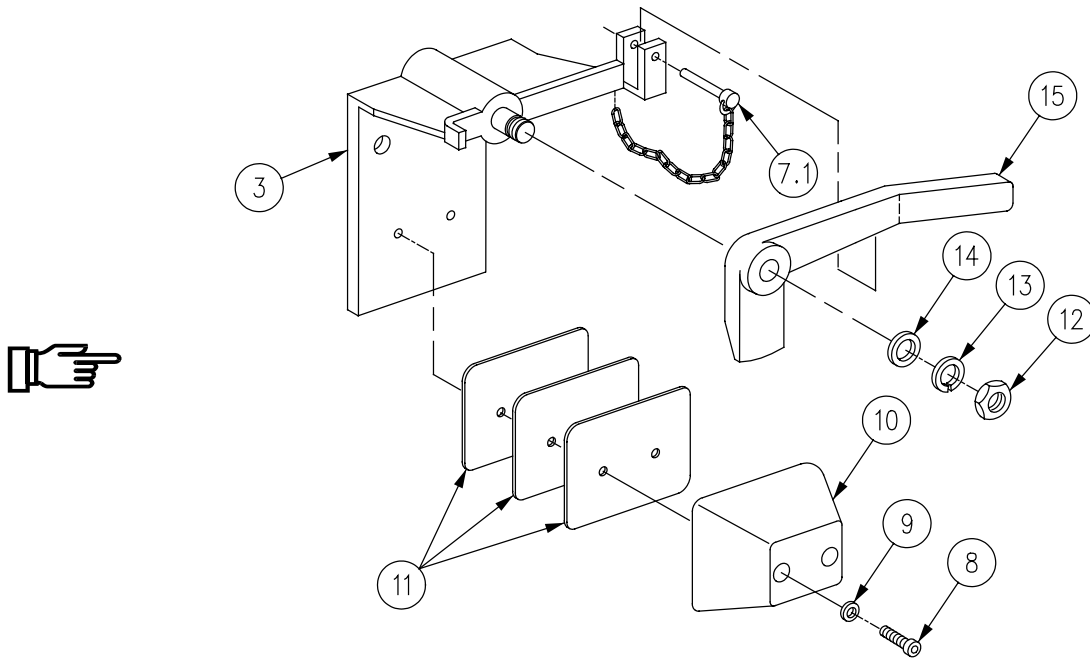

INSTALLATION

1. Install control handle (15), flat washer (14), new lock washer (13), and new lock nut (12) on mounting bracket (3).
2. Install three spacers (11) rubber bumper (10), two screws (8), and flat washers (9), on mounting bracket (3).
3. Install locking pin assembly (7.1), on mounting bracket (3).

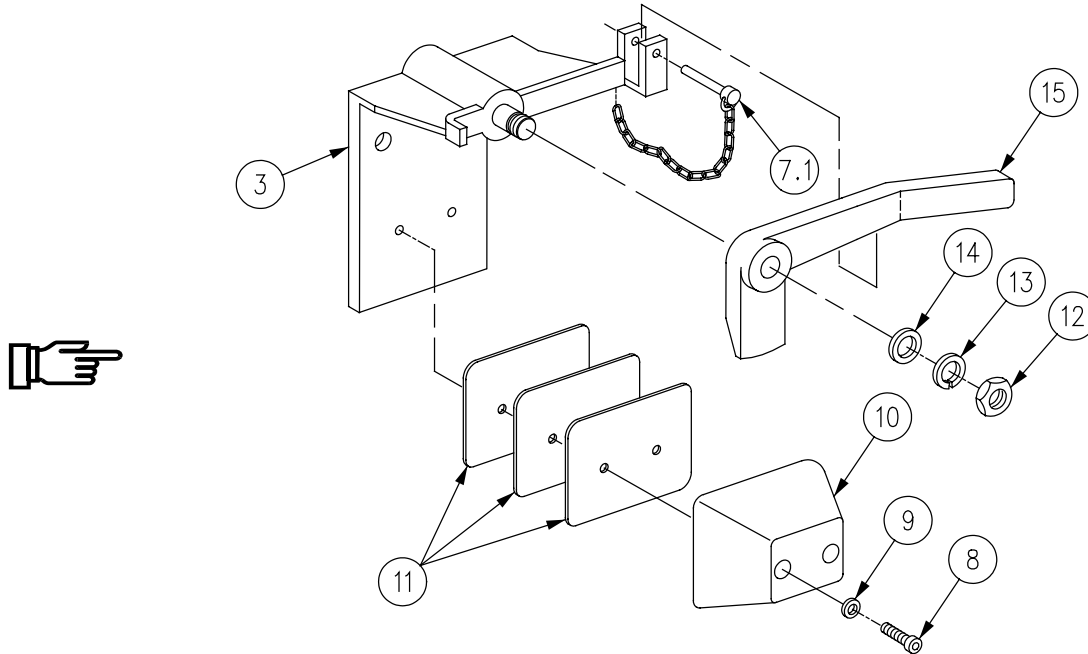

4. Install mounting bracket (7) on exterior bulkhead with four washers (5), new lock washers (6) and screws (4).
5. Install mounting bracket (3) on exterior bulkhead with three washers (2) and screws (1).

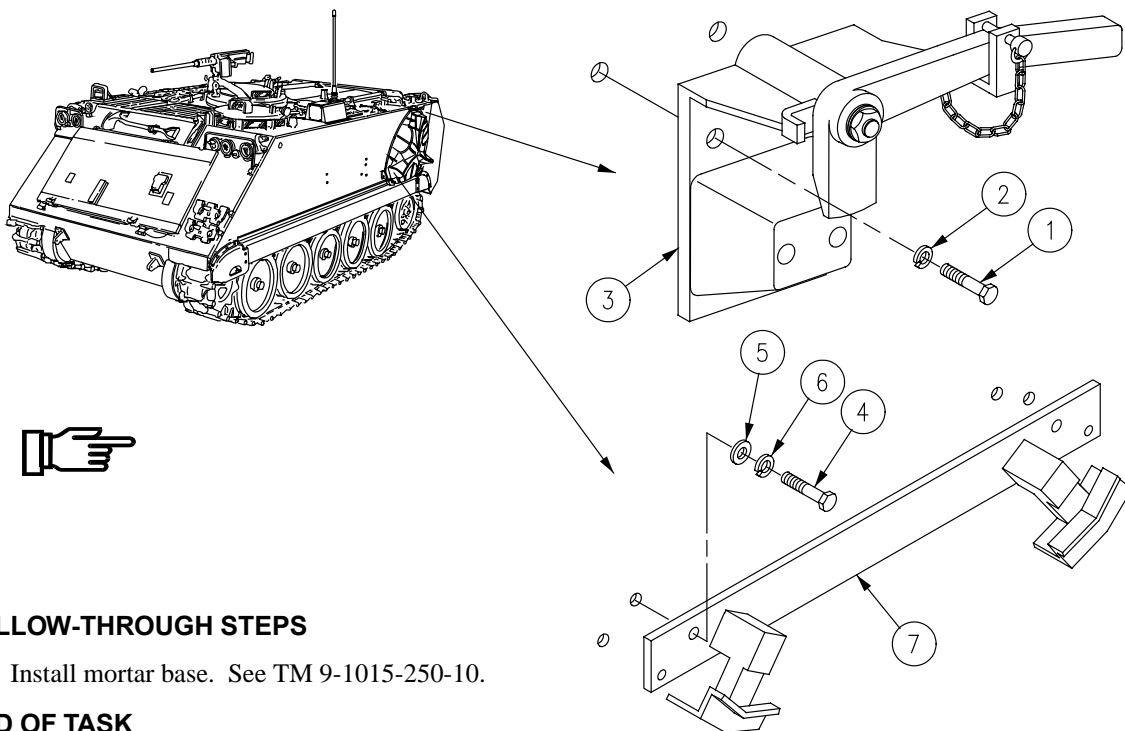

FOLLOW-THROUGH STEPS

1. Install mortar base. See TM 9-1015-250-10.

END OF TASK

REPLACE LEFT SIDE RACK BASE (M1068A3 ONLY)

0616 00

THIS WORK PACKAGE COVERS:

Removal (page 0616 00-1).
 Installation (page 0616 00-3).

INITIAL SETUP:

Maintenance Level

Unit

References

See your -10
 TM 11-7010-256-12&P

Tools and Special Tools

General Mechanic's Tool Kit (WP 0926 00, Item 65)

Equipment Condition

Engine stopped (see your -10)
 Carrier blocked (see your -10)
 Ramp lowered (see your -10)
 Electronic/Communication equipment removed
 (TM 11-7010-256-12&P)
 A.C. and D.C. power extension boxes and mounts
 removed (WP 0834 00)
 U.P.S. power extension box removed (WP 0822 00)
 Printer mount removed (WP 0823 00)

Materials/Parts

Locknut (10)

Personnel Required

Unit Mechanic

REMOVAL

1. Remove eight screws (1) and two bumpers (2) from rack base (3).
2. Remove two pins (4), lower two work surface assemblies (5), and remove two springs (6).
3. Raise two work surface assemblies (5). Remove four locknuts (7), screws (8), washers (9), washers (10), and two work surface assemblies (5) from rack base (3). Discard locknuts.
4. Remove two screws (11), washers (12), and pins (4) with lanyards from two frames (13).

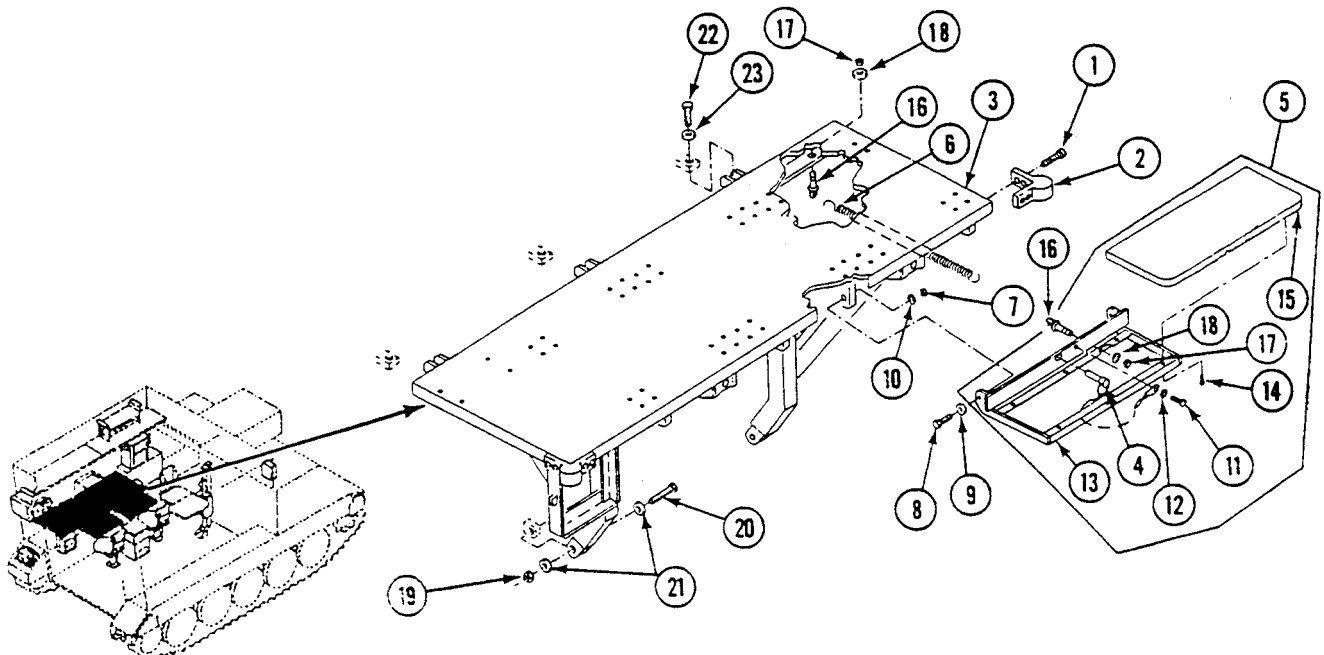

REPLACE LEFT SIDE RACK BASE (M1068A3 ONLY) — Continued

0616 00

5. Remove 12 screws (14), and 2 work surfaces (15) from 2 frames (13).
6. Remove two bolts (16), locknuts (17), and washers (18) from two frames (13). Discard locknuts.
7. Remove two bolts (16), locknuts (17), and washers (18) from rack base (3). Discard locknuts.
8. Remove two locknuts (19), screws (20), four washers (21), and rack base (3) from sponson lugs. Discard locknuts.
9. Remove three screws (22), washers (23), and rack base (3) from bulkhead mounts.

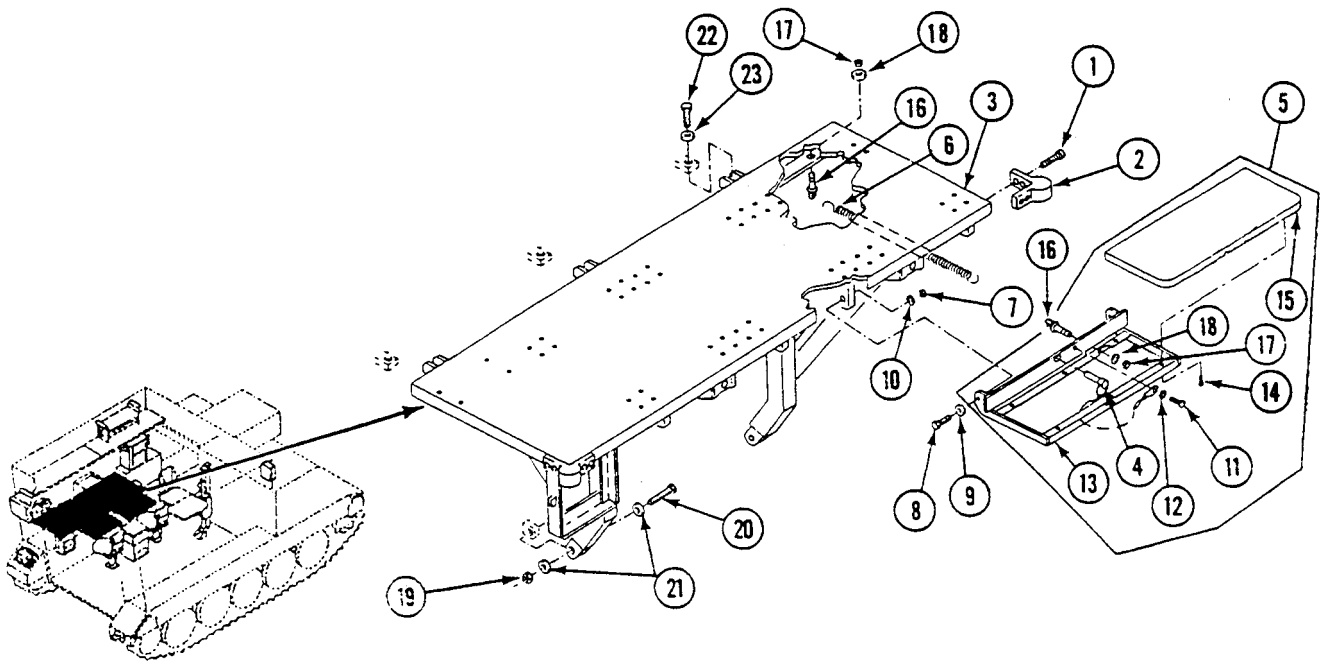

INSTALLATION

1. Install two bolts (1), washers (2), and new locknuts (3) in rack base (4).
2. Position rack base (4) on bulkhead mounts. Secure with three washers (5) and screws (6).
3. Position rack base (4) to sponson lugs. Secure with four washers (7), two screws (8), and new locknuts (9).
4. Install two bolts (1), washers (2), and new locknuts (3) in two frames (10).
5. Install two work surfaces (11) and 12 screws (12) on two frames (10).
6. Install two pins (13) with lanyards, washers (14), and screws (15) on frames (10).

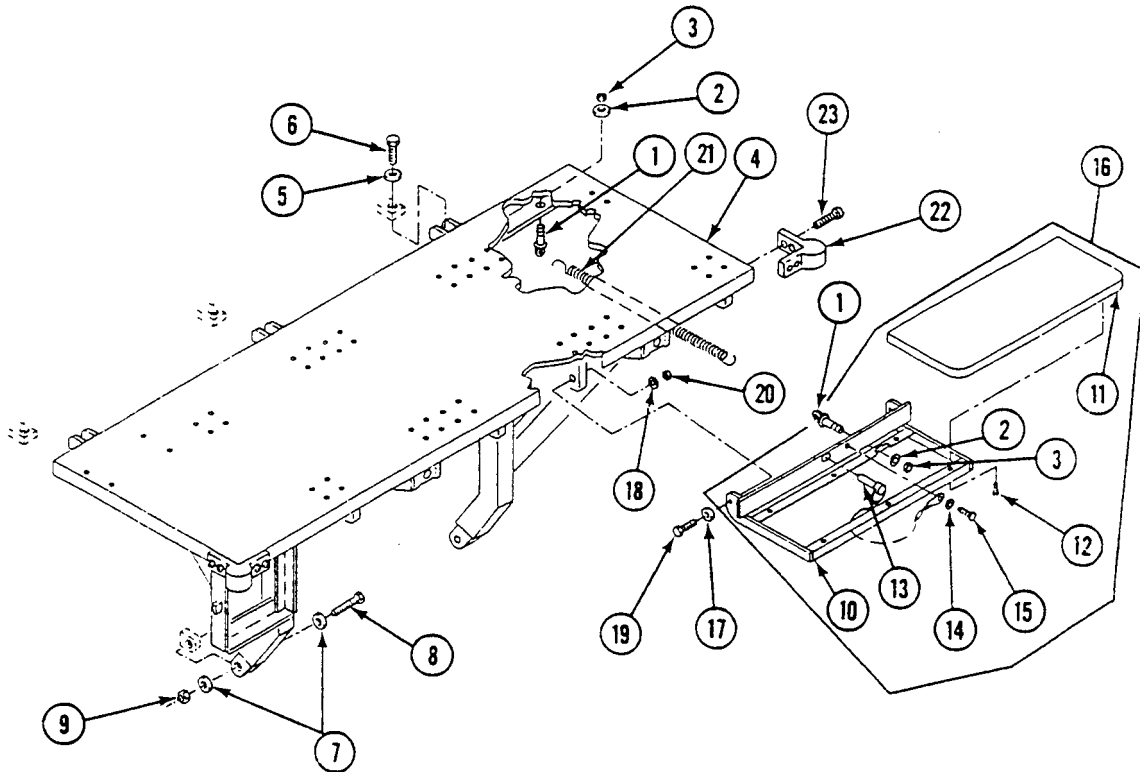

REPLACE LEFT SIDE RACK BASE (M1068A3 ONLY) — Continued

0616 00

7. Position two work surface assemblies (16) under rack base (4). Secure with four washers (17), washers (18), screws (19), and new locknuts (20).
8. Install two springs (21) onto four bolts (1).
9. Install two bumpers (22) and eight screws (23) on rack base (4).
10. Install two pins (13) in work surface assemblies (16).

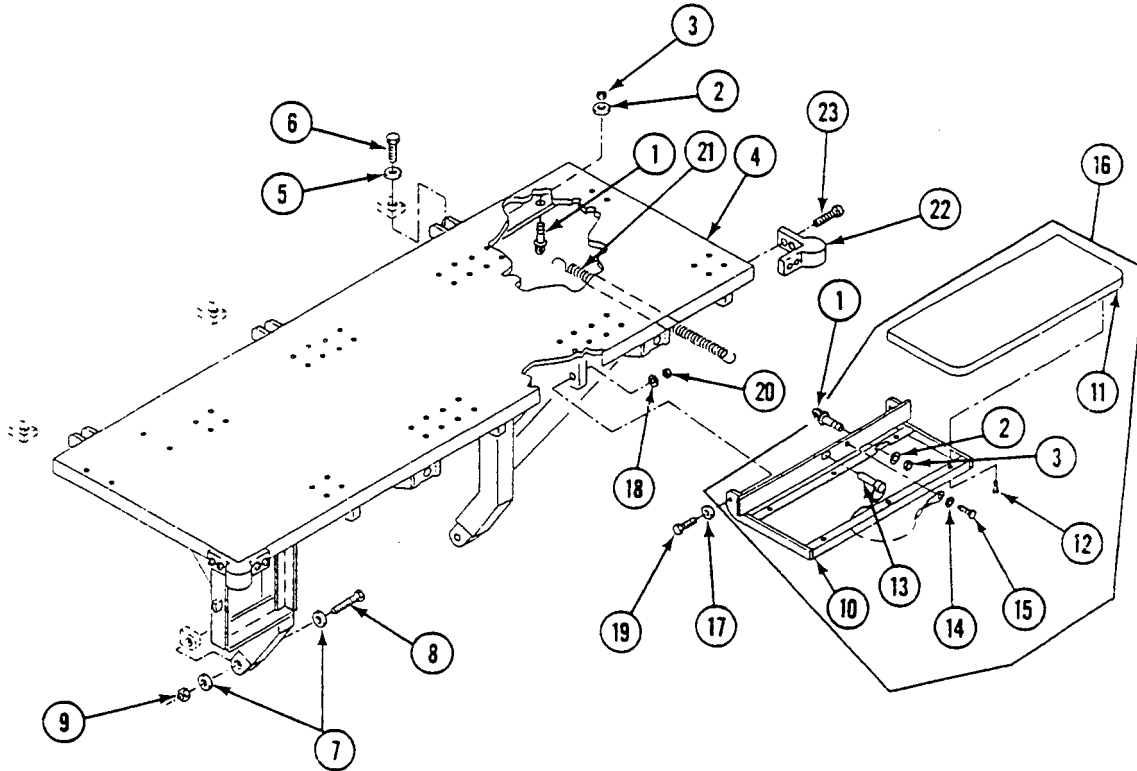

FOLLOW-THROUGH STEPS

1. Install printer mount (WP 0823 00).
2. Install U.P.S. power extension box (WP 0822 00).
3. Install A.C. and D.C. power extension boxes and mounts (WP 0834 00).
4. Install electronic/communication equipment. See TM 11-7010-256-12&P.
5. Start engine (see your -10).
6. Raise and lock ramp (see your -10).
7. Stop engine (see your -10).

END OF TASK

REPLACE PERSONNEL HEATER CONTROL BOX AND INTERCOM BOX BRACKET (M1068A3 ONLY)

0617 00

THIS WORK PACKAGE COVERS:

Removal (page 0617 00-1).
 Installation (page 0617 00-2).

INITIAL SETUP:

Maintenance Level

Unit

References

See your -10
 TM 11-7010-256-12&P

Tools and Special Tools

General Mechanic's Tool Kit (WP 0926 00, Item 65)
 Electrical Tool Kit (WP 0926 00, Item 64)

Equipment Condition

Engine stopped (see your -10)
 Carrier blocked (see your -10)
 All external power disconnected
 (TM 11-7010-256-12&P)
 Battery ground lead disconnected (WP 0338 00)
 Personnel heater control box removed (WP 0701 00)

Materials/Parts

Lockwasher (2)
 Lockwasher (2)

Personnel Required

Unit Mechanic

REMOVAL

NOTE

Make sure that intercom box is free to be removed.

1. Remove two screws (1), lockwashers (2), and intercom box (3) from bracket (4). Discard lockwashers.
2. Remove two screws (5), lockwashers (6), and bracket (4) from beam on hull. Discard lockwashers.

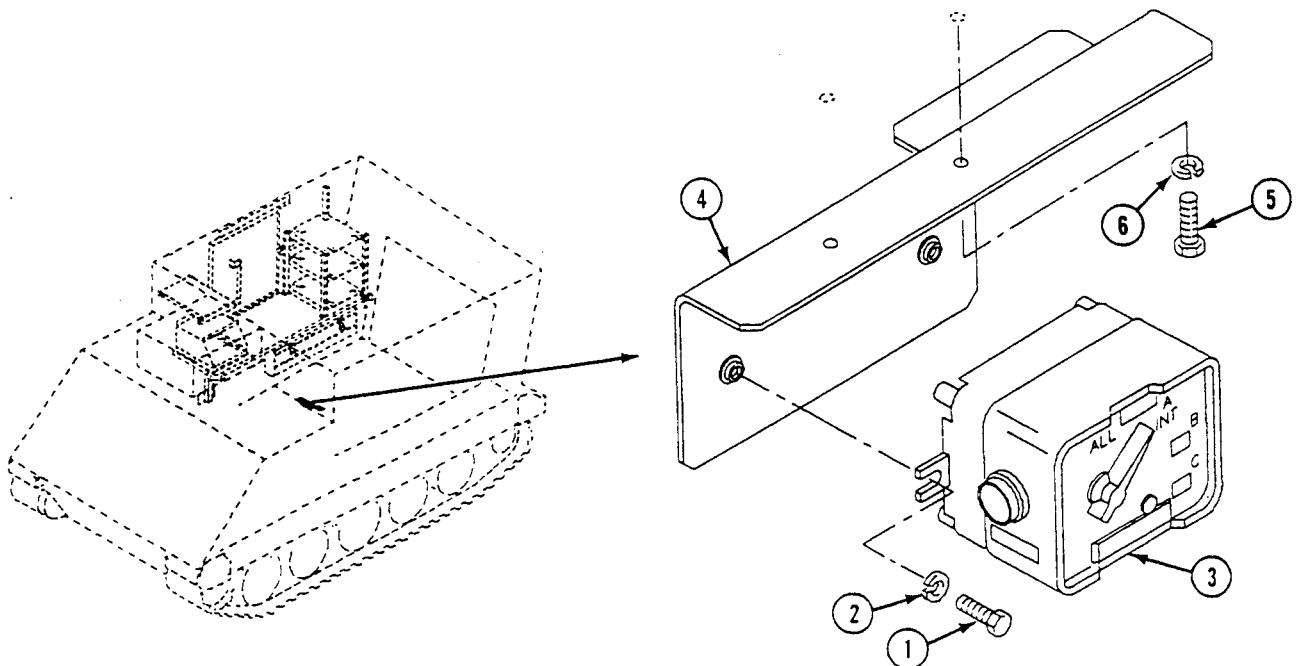

**REPLACE PERSONNEL HEATER CONTROL BOX AND INTERCOM BOX BRACKET
(M1068A3 ONLY) — Continued**

0617 00

INSTALLATION

1. Install bracket (4), two new lockwashers (6), and screws (5) to beam on hull.
2. Install intercom box (3), two new lockwashers (2), and screws (1) to bracket (4).

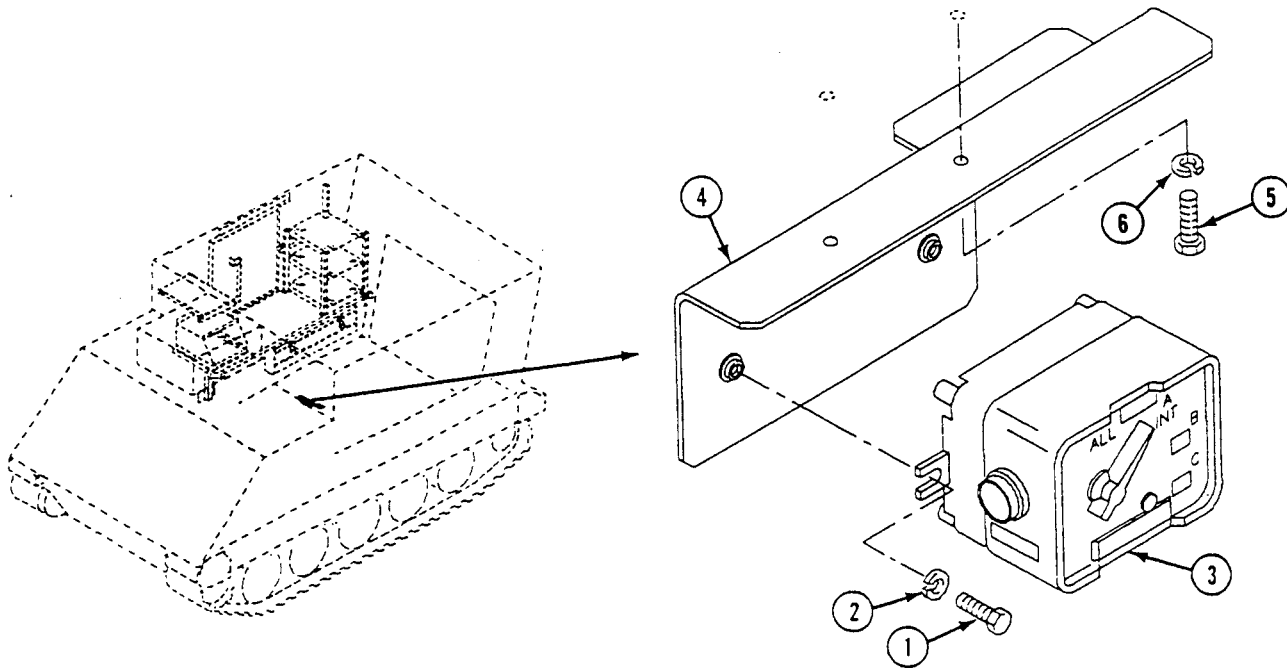
**FOLLOW-THROUGH STEPS**

1. Install personnel heater control box (WP 0701 00).
2. Connect battery ground lead (WP 0338 00).

END OF TASK

REPLACE/REPAIR MAP BOARD (M1068A3 ONLY)

0618 00

THIS WORK PACKAGE COVERS:

Removal (page 0618 00-1).
 Installation (page 0618 00-3).

INITIAL SETUP:

Maintenance Level

Unit

Personnel Required

Unit Mechanic

Tools and Special Tools

General Mechanic's Tool Kit (WP 0926 00, Item 65)

References

See your -10

Materials/Parts

Locknut (4)
 Locknut (6)

Equipment Condition

Engine stopped (see your -10)
 Carrier blocked (see your -10)
 Ramp lowered (see your -10)

REMOVAL

1. Remove strap (1) securing map board.
2. Remove two screws (17), washers (2), and map board assembly (3) from right side bulkhead mounts.
3. Remove two tips (4) from two stakes (5).

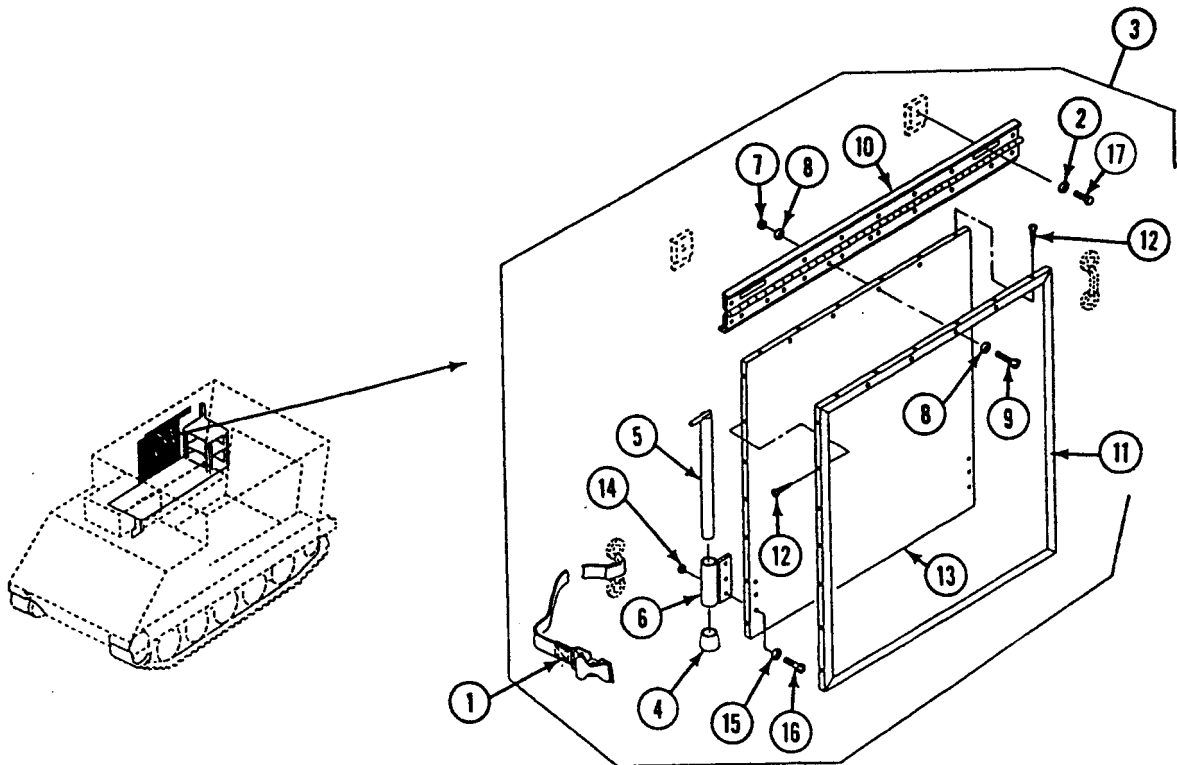

4. Remove two stakes (5) from two brackets (6).
5. Remove four locknuts (7), eight washers (8), four screws (9), and hinge (10) from frame (11). Discard locknuts.
6. Remove 14 screws (12) from sides of frame (11).
7. Remove 12 screws (12) and frame (11) from map board (13).
8. Remove six locknuts (14), washers (15), screws (16), and two brackets (6) from map board (13). Discard locknuts.

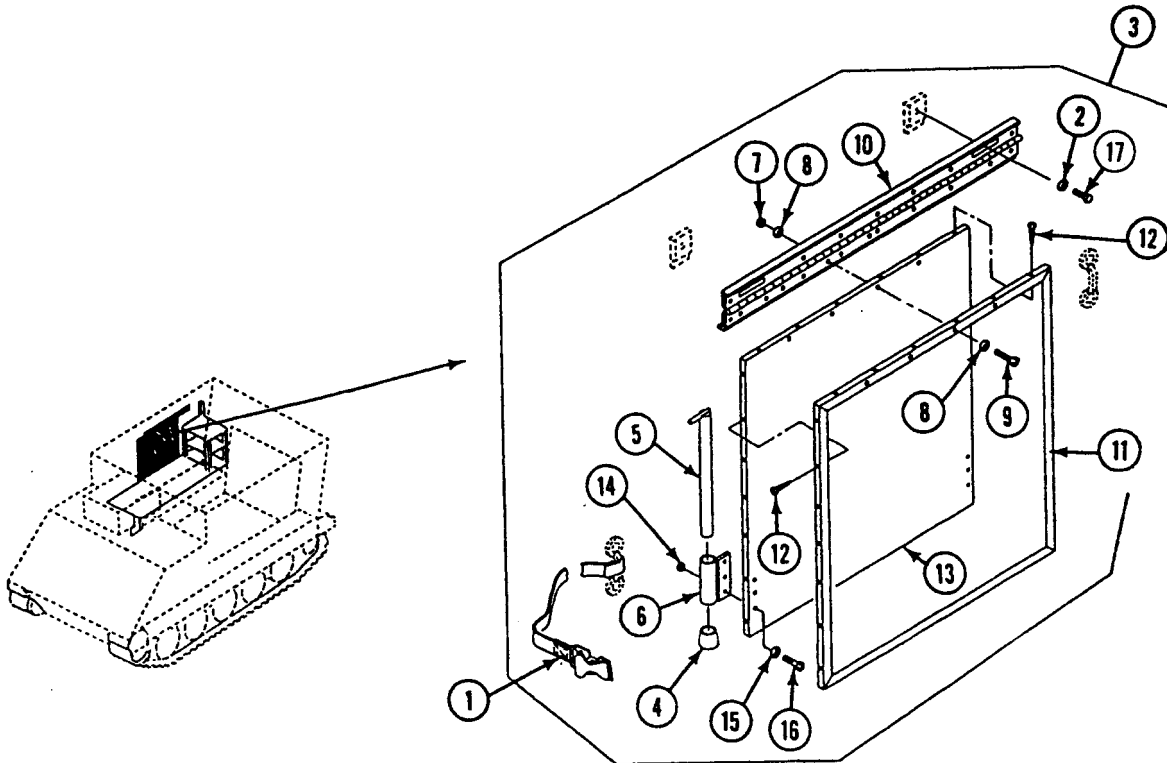

INSTALLATION

1. Install two brackets (1), new locknuts (2), washers (3), and six screws (4) on map board (5).
2. Install frame (6) and 12 screws (7) on map board (5).
3. Install 14 screws (7) in sides of frame (6).
4. Install hinge (8), new locknuts (9), eight washers (10), and four screws (11) on frame (6).
5. Install two stakes (12) in brackets (1).
6. Install two tips (13) on stakes (12).
7. Install strap (17) to secure map board.
8. Align map board assembly (14) with right side bulkhead mounts. Secure with two screws (15) and washers (16).

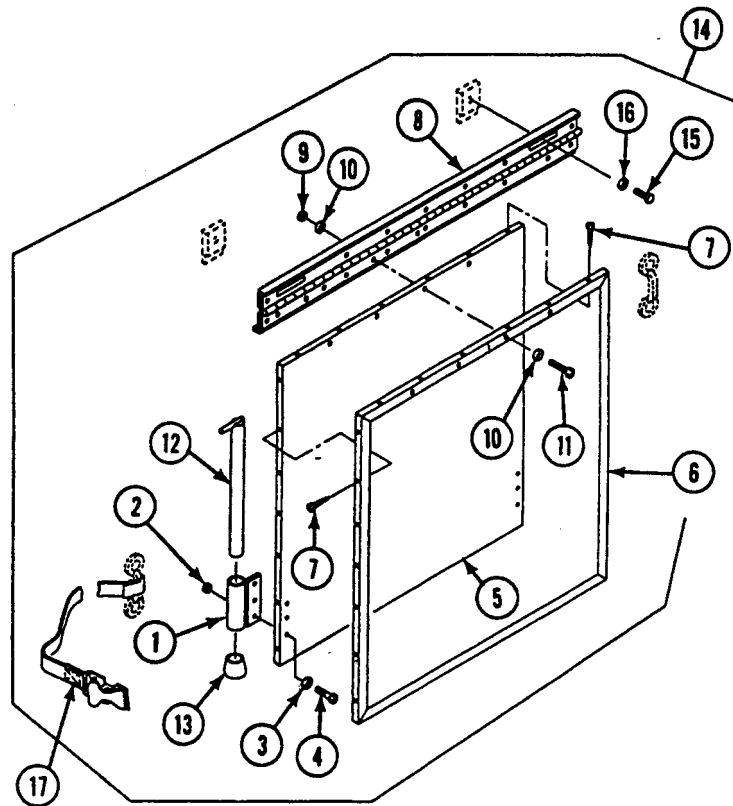
**FOLLOW-THROUGH STEPS**

1. Start engine (see your -10).
2. Raise and lock ramp (see your -10).
3. Stop engine (see your -10).

END OF TASK

REPLACE MAP STORAGE BOX (M1068A3 ONLY)

0619 00

THIS WORK PACKAGE COVERS:

- Removal (page 0619 00-1).
- Installation (page 0619 00-2).

INITIAL SETUP:

Maintenance Level

Unit

References

See your -10

Tools and Special Tools

General Mechanic's Tool Kit (WP 0926 00, Item 65)

Equipment Condition

Engine stopped (see your -10)

Personnel Required

Unit Mechanic

Carrier blocked (see your -10)

REMOVAL

1. Remove two screws (1) and washers (2) from storage box (3) and two right side rack base legs (4).
2. Remove five screws (1), washers (2), and storage box (3) from right side rack base (5).

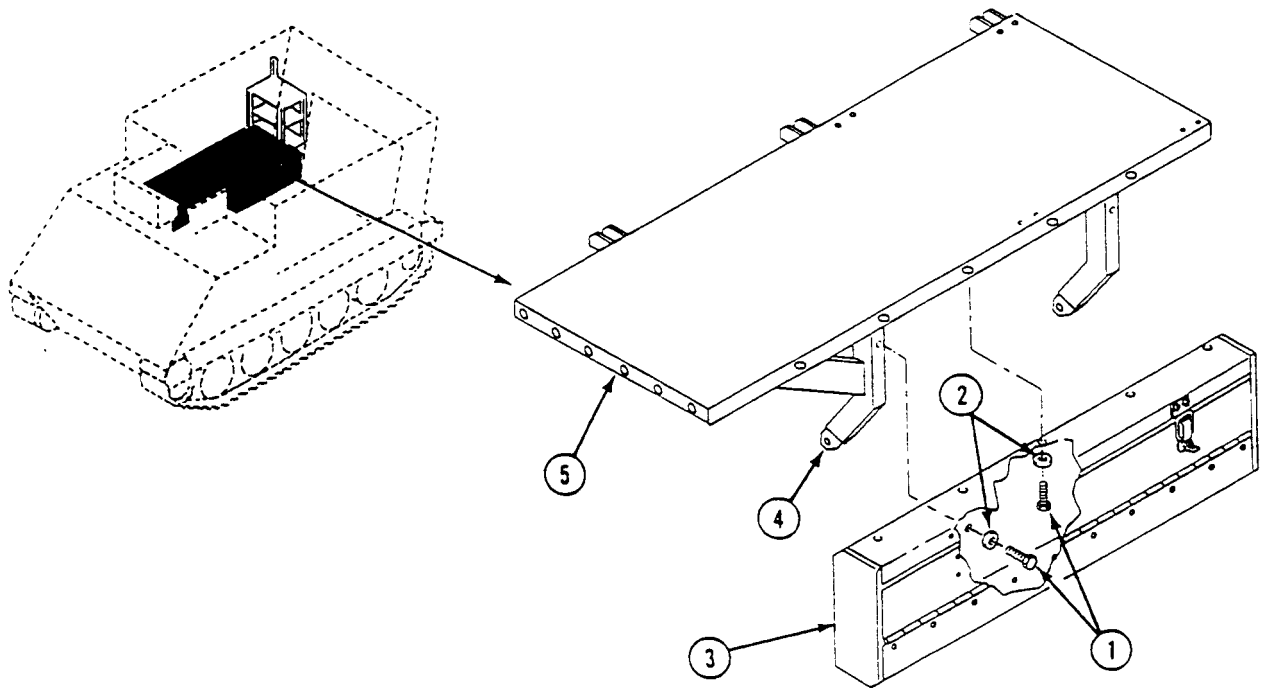

INSTALLATION

1. Position map storage box (3) under top of right side rack base (5). Secure with five washers (2) and screws (1).
2. Position map storage box (3) to two right side rack base legs (4). Secure with two washers (2) and screws (1).

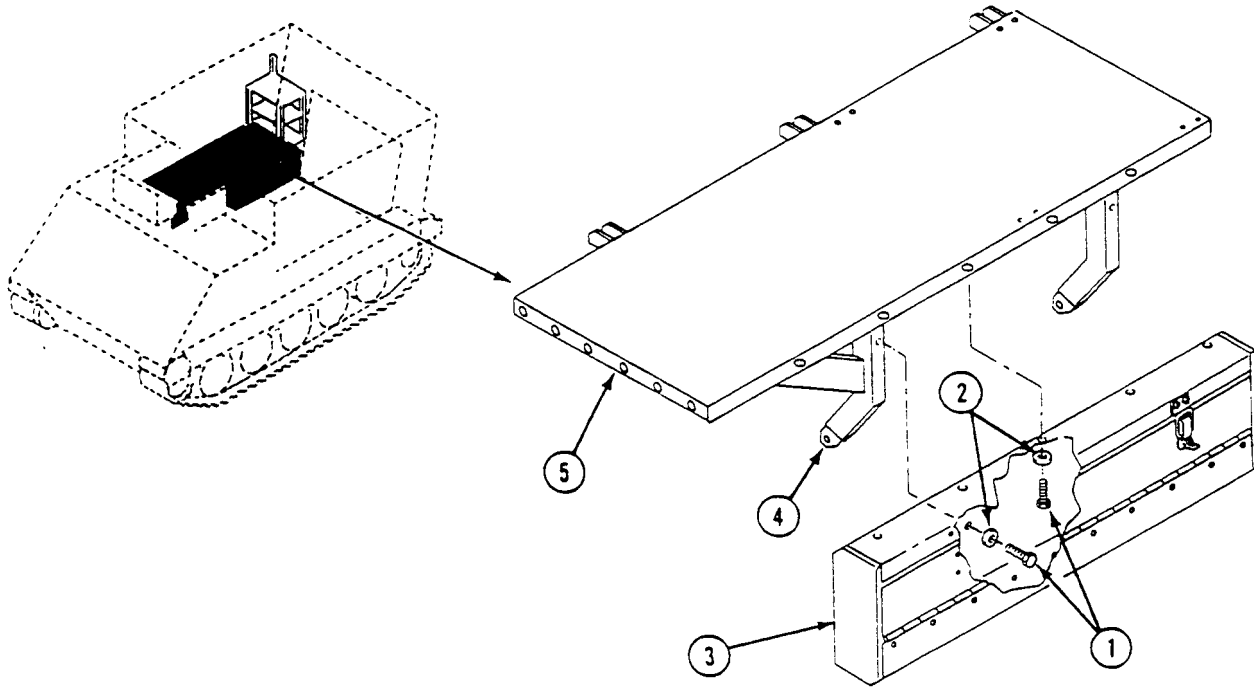
**END OF TASK**

REPAIR MAP STORAGE BOX (M1068A3 ONLY)

0620 00

THIS WORK PACKAGE COVERS:

Disassembly (page 0620 00-1).
 Assembly (page 0620 00-2).

INITIAL SETUP:

Maintenance Level

Unit

References

See your -10

Tools and Special Tools

General Mechanic's Tool Kit (WP 0926 00, Item 65)

Equipment Condition

Engine stopped (see your -10)

Carrier blocked (see your -10)

Ramp lowered (see your -10)

Map storage box removed (WP 0619 00)

Personnel Required

Unit Mechanic

DISASSEMBLY

1. Remove four screws (1), washers (2), nuts (3), and catch (4) from door (5).
2. Remove four screws (1), washers (2), nuts (3), and strike (6) from map storage box (7).
3. Remove 10 screws (1), 20 washers (2), 10 nuts (3), and door (5) from map storage box (7).

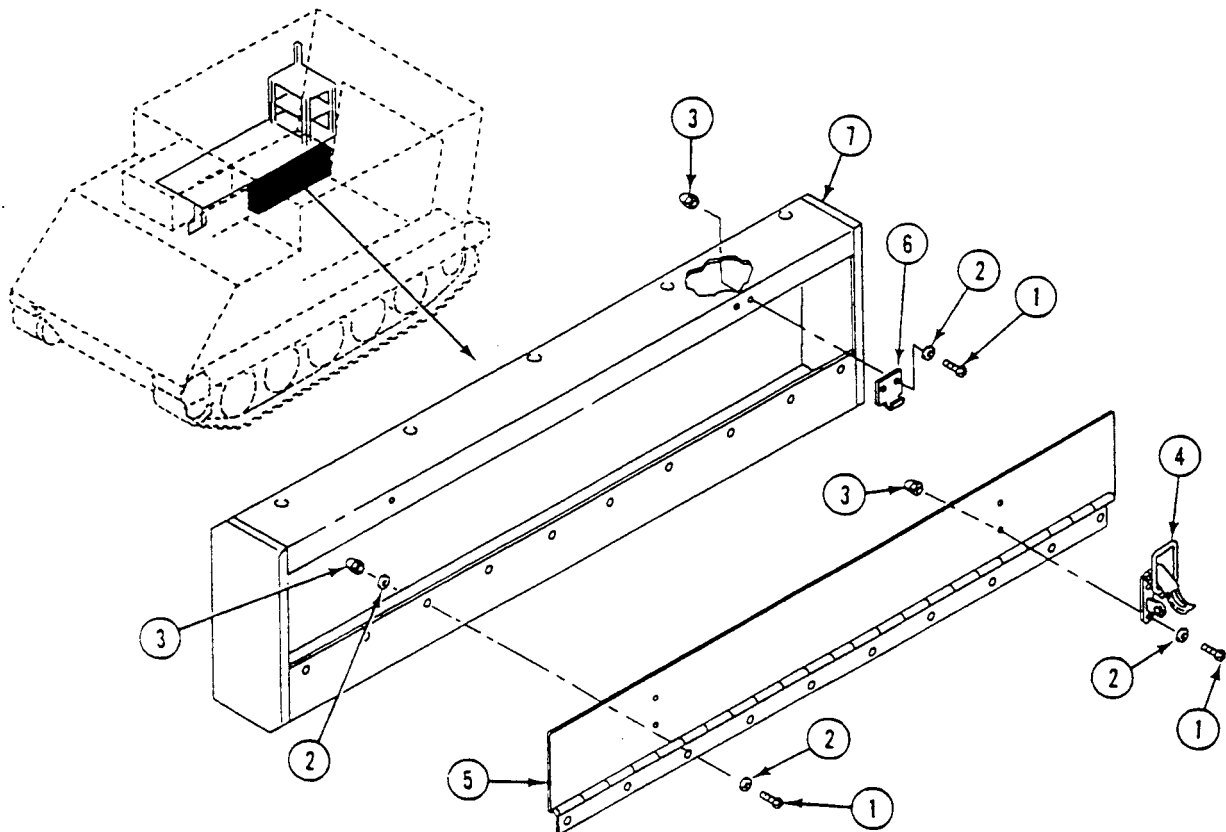

ASSEMBLY

1. Install door (1), 20 washers (2), 10 screws (3), and nuts (4) on map storage box (5).
2. Install strike (6), four washers (2), screws (3), and nuts (4) on map storage box (5).
3. Using catch (7) as a template, drill four 0.191-0.208 holes through door (1). Paint strike and catch number 24533 green per MIL-C-22750.
4. Install catch (7), four washers (2), screws (3), and nuts (4) on door (1).

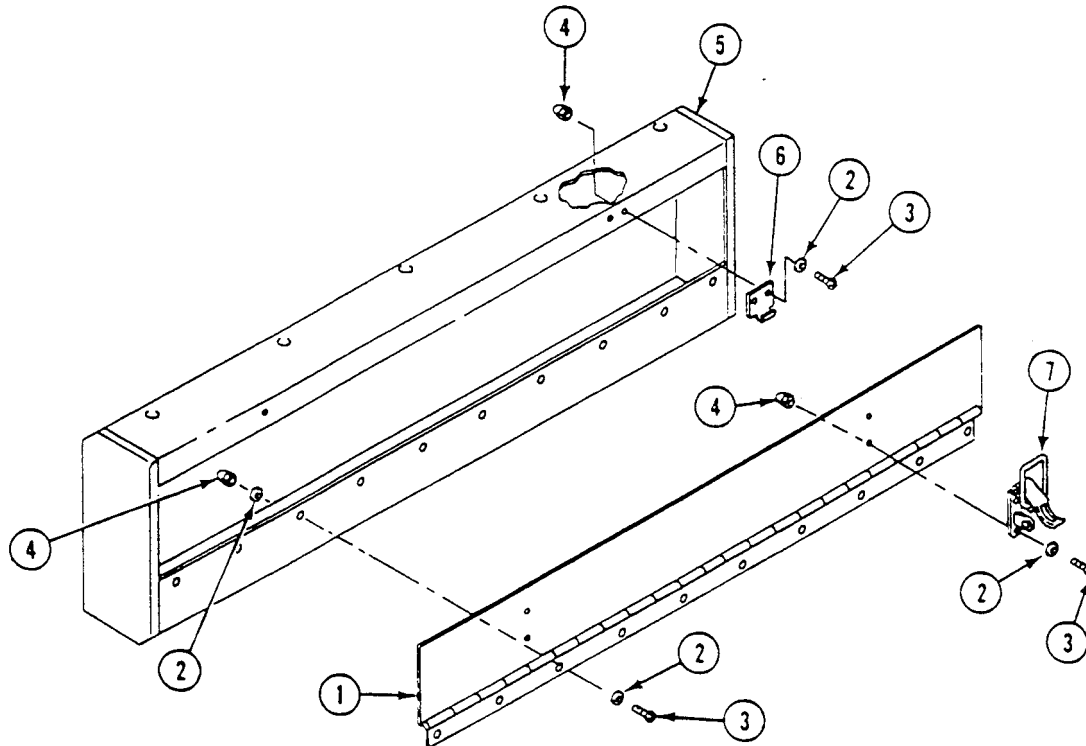
**FOLLOW-THROUGH STEPS**

1. Install map storage box (WP 0619 00).
2. Start engine (see your -10).
3. Raise and lock ramp (see your -10).
4. Stop engine (see your -10).

END OF TASK

REPLACE RIGHT SIDE SHELF ASSEMBLY (M1068A3 ONLY)

0621 00

THIS WORK PACKAGE COVERS:

Removal (page 0621 00-1).
 Installation (page 0621 00-3).

INITIAL SETUP:

Maintenance Level

Unit

References

See your -10
 TM 11-7010-256-12&P

Tools and Special Tools

General Mechanic's Tool Kit (WP 0926 00, Item 65)

Equipment Condition

Engine stopped (see your -10)
 Carrier blocked (see your -10)
 Ramp lowered (see your -10)
 Battery ground lead disconnected (WP 0338 00)
 Electrical/communication equipment removed
 (TM 11-7010-256-12&P)
 A.C. power extension box A7 removed (WP 0815 00)
 UPS power extension box A17 removed (WP 0822 00)
 LAN ground box assembly A15 removed (WP 0820 00)
 Right equipment rack brackets and mounts removed
 (WP 0814 00)

Materials/Parts

Locknut (28)
 Locknut (2)

Personnel Required

Unit Mechanic

REMOVAL

1. Remove two locknuts (1), screws (2), and four washers (3) from two vertical posts (4) and bracket (5). Discard locknuts.

REPLACE RIGHT SIDE SHELF ASSEMBLY (M1068A3 ONLY) — Continued

0621 00

2. Remove two nuts (6) and washers (7) from bottom of each of four posts (4) and base (8). Move shelf assembly to work station.
3. Remove two locknuts (9), screws (10), four washers (11), and bracket (5) from bracket (12). Discard locknuts.
4. Remove two locknuts (13), screws (14), four washers (15), and bracket (12) from right bulkhead. Discard locknuts.
5. Remove 24 locknuts (16), screws (17), 48 washers (18), and three shelves (19) from four posts (4). Discard locknuts.

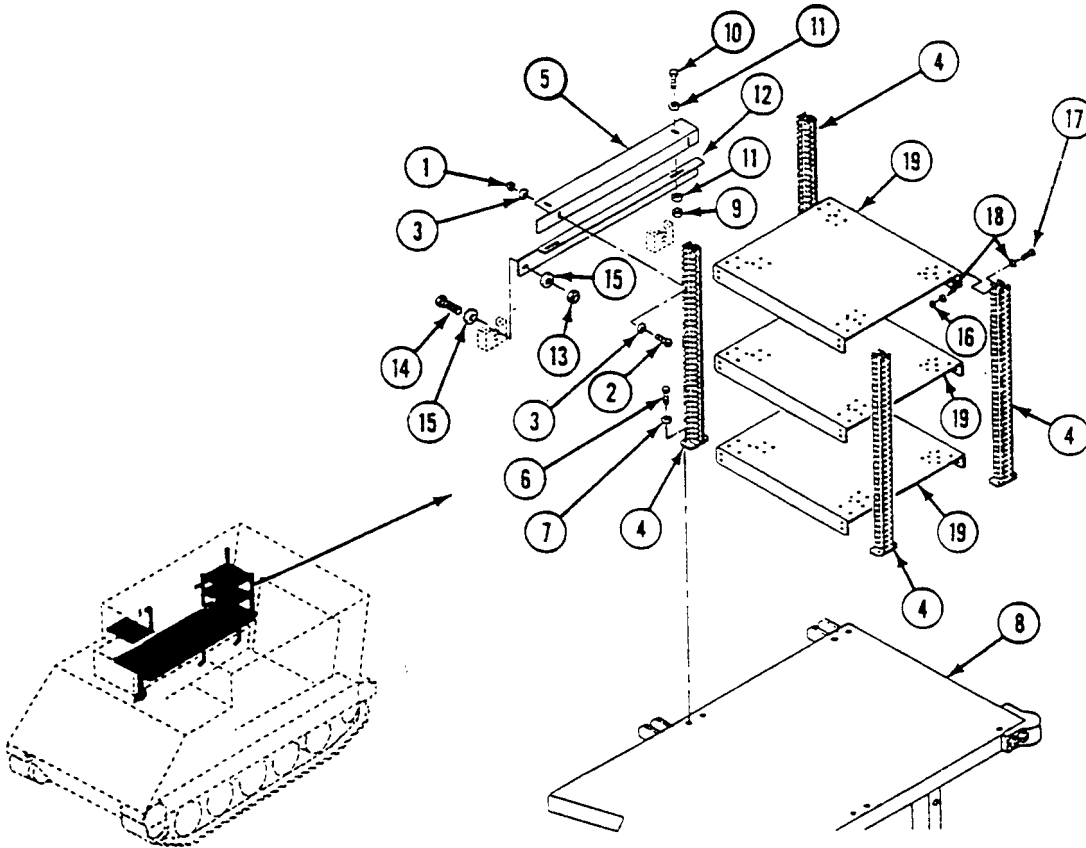

INSTALLATION

1. Position three shelves (1) on four vertical posts (2). Secure with 24 screws (3), 48 washers (4), and 24 new locknuts (5).
2. Install bracket (6), four washers (7), two screws (8), and new locknuts (9) on right bulkhead.
3. Install bracket (10), four washers (11), two screws (12), and new locknuts (13) on bracket (6).
4. Position shelf assembly on base (14). Secure each of four posts (2) to base (14) with two washers (15) and screws (16).
5. Install four washers (17), two screws (18), and new locknuts (19) in two posts (2) and bracket (10).

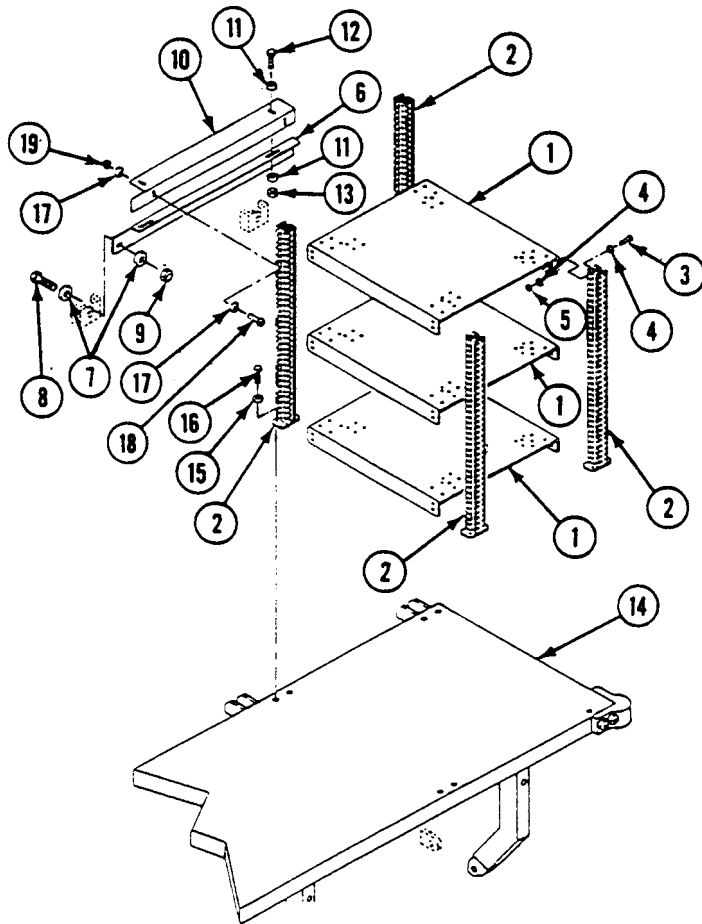

FOLLOW-THROUGH STEPS

1. Install right equipment rack brackets and mounts (WP 0814 00).
2. Install LAN ground box assembly A15 (WP 0820 00).
3. Install UPS power extension box A17 (WP 0822 00)
4. Install A.C. power extension box A7 (WP 0815 00).
5. Install electrical/communication equipment. See TM 11-7010-256-12&P.
6. Connect battery ground lead (WP 0338 00).
7. Start engine (see your -10).
8. Raise and lock ramp (see your -10).
9. Stop engine (see your -10).

END OF TASK

REPLACE RIGHT SIDE RACK BASE (M1068A3 ONLY)

0622 00

THIS WORK PACKAGE COVERS:

Removal (page 0622 00-1).
 Installation (page 0622 00-3).

INITIAL SETUP:

Maintenance Level

Unit

References

See your -10

Tools and Special Tools

General Mechanic's Tool Kit (WP 0926 00, Item 65)

Equipment Condition

Engine stopped (see your -10)
 Carrier blocked (see your -10)
 Ramp lowered (see your -10)
 Battery ground lead disconnected (WP 0338 00)
 Batteries removed (WP 0347 00)
 Right side shelf assembly removed (WP 0621 00)

Materials/Parts

Cotter pin
 Locknut (2)
 Lockwasher (8)

Personnel Required

Unit Mechanic

REMOVAL

1. Remove four screws (1) and bumper (2) from base extension (3).
2. Remove three screws (1) and bumper (2) from base (4).
3. Loosen two nuts (5)(6) and pivot bolt (7) securing base extension (3). Raise base extension and position on base (4).
4. Remove 12 screws (8) and hinge (9) from base extension (3) and base (4).

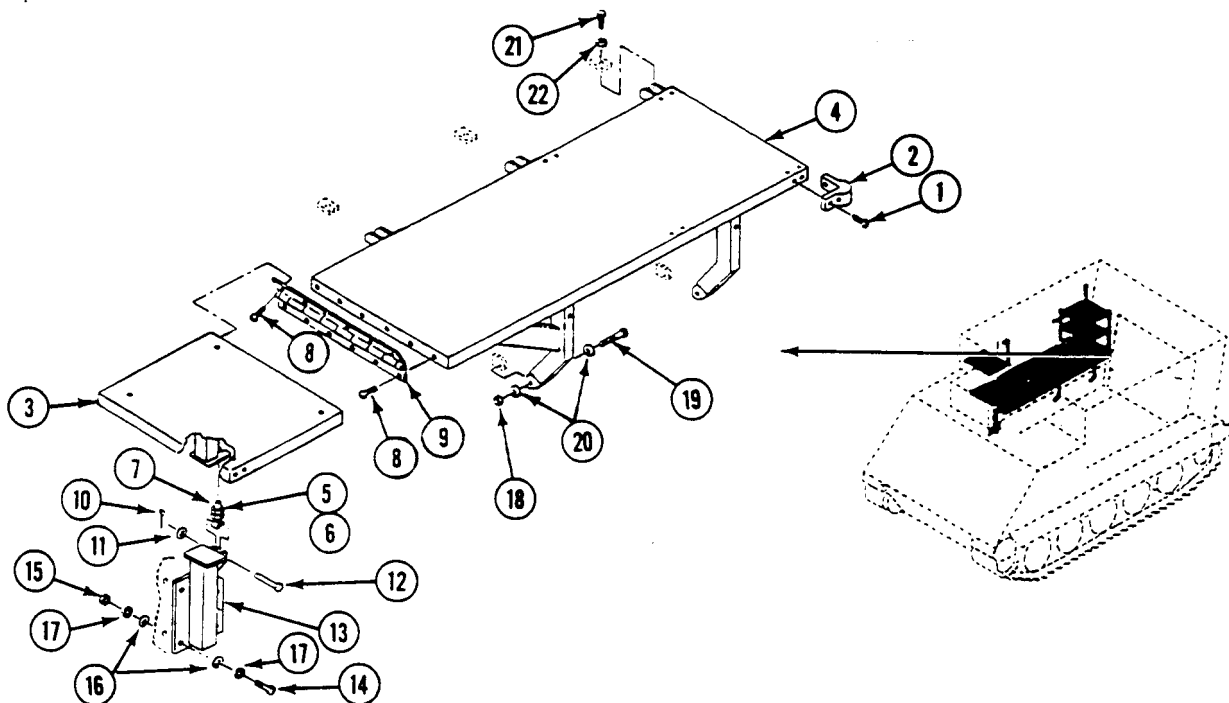

REPLACE RIGHT SIDE RACK BASE (M1068A3 ONLY) — Continued

0622 00

5. Remove cotter pin (10), washer (11), headed pin (12), and bolt (7) from base extension mount (13). Discard cotter pin.
6. Remove four screws (14), nuts (15), eight washers (16), lockwashers (17), and base extension mount (13) from right sponson. Discard lockwashers.
7. Remove two locknuts (18), screws (19), and four washers (20) from base (4) and sponson. Discard locknuts.
8. Remove three screws (21), washers (22), and base (4) from bulkhead mounts.

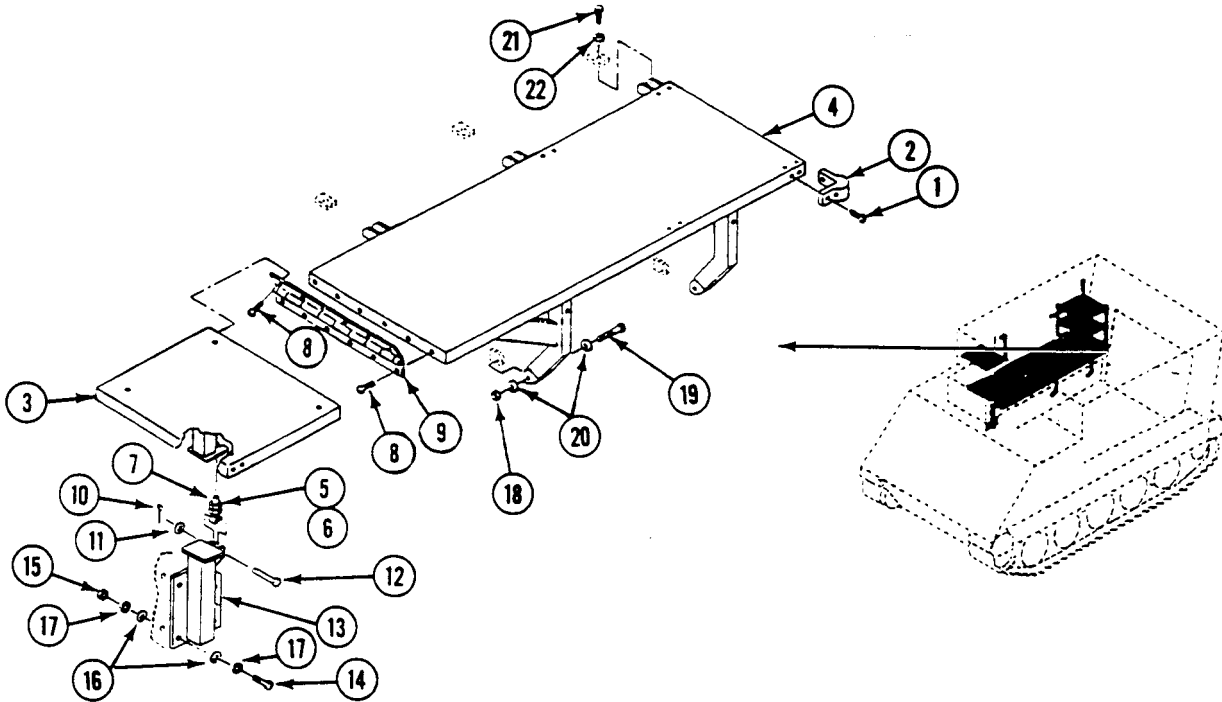

INSTALLATION

1. Position base (1) on bulkhead mounts. Secure with three washers (2) and screws (3).
2. Install four washers (4), two screws (5), and new locknuts (6) on base (1) and sponson.
3. Position base extension mount (7) on battery box. Secure with four screws (8), eight washers (9), new lockwashers (10), and four nuts (11)
4. Install bolt (12), headed pin (13), washer (14), and new cotter pin (15) on base extension mount (7).

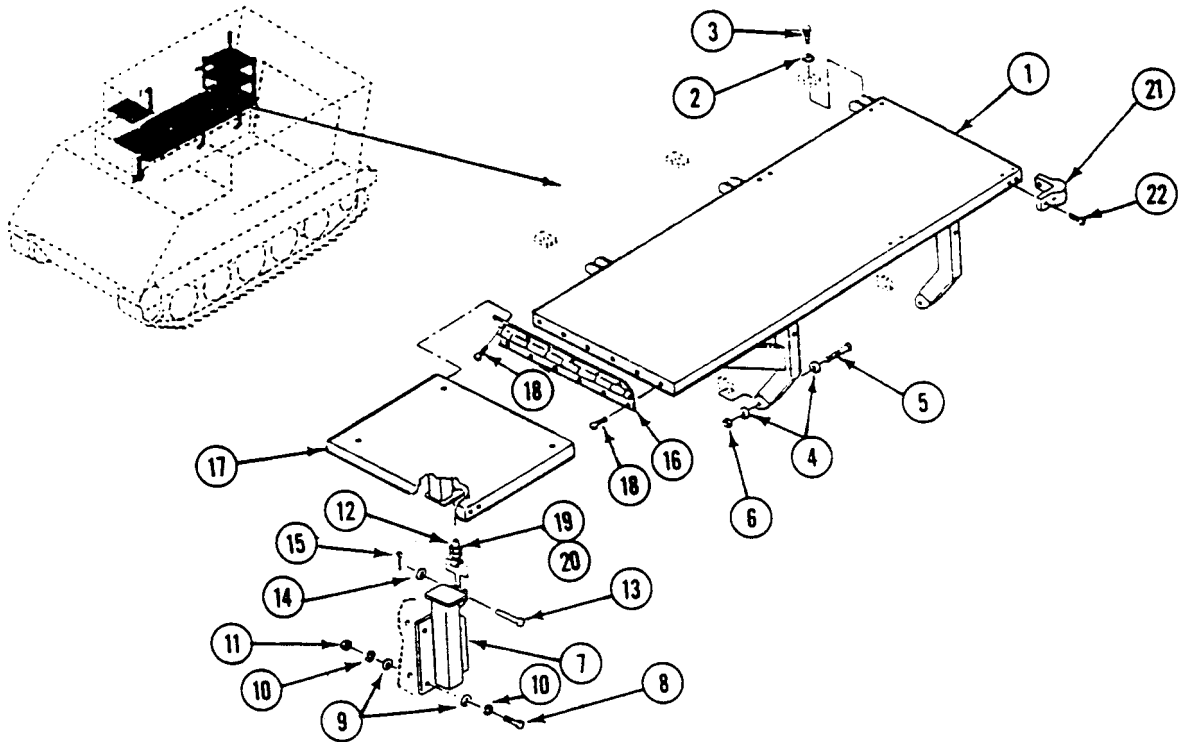

REPLACE RIGHT SIDE RACK BASE (M1068A3 ONLY) — Continued**0622 00**

5. Position hinge (16) between base (1) and base extension (17). Secure with 12 screws (18).
6. Position base extension (17) on bolt (12) on base extension mount (7). Secure with new two nuts (19)(20).
7. Install bumper (21) on base extension (17). Secure with four screws (22).
8. Install bumper (21) on base (1). Secure with three screws (22).

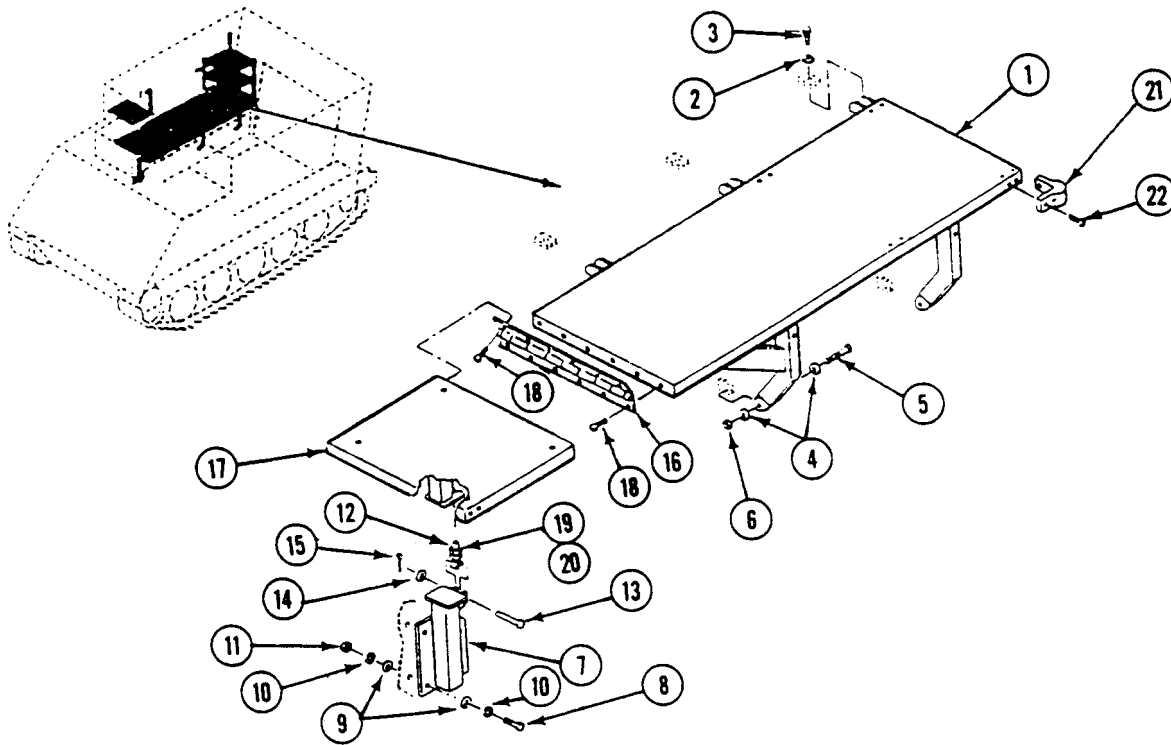
**FOLLOW-THROUGH STEPS**

1. Install right side shelf assembly (WP 0621 00).
2. Install batteries (WP 0347 00).
3. Connect battery ground lead (WP 0338 00).
4. Start engine (see your -10).
5. Raise and lock ramp (see your -10).
6. Stop engine (see your -10).

END OF TASK

REPLACE RIGHT SIDE BASE EXTENSION (M1068A3 ONLY)

0623 00

THIS WORK PACKAGE COVERS:

- Removal (page 0623 00-1).
- Installation (page 0623 00-3).
- Adjustment (page 0623 00-4).

INITIAL SETUP:

Maintenance Level

Unit

Personnel Required

Unit Mechanic

Tools and Special Tools

General Mechanic's Tool Kit (WP 0926 00, Item 65)

References

See your -10

Materials/Parts

- Cotter pin (2)
- Lockwasher (10)

Equipment Condition

- Engine stopped (see your -10)
- Carrier blocked (see your -10)

REMOVAL

1. Loosen two nuts (1) securing bolt (2) to base extension (3).
2. Pivot bolt (2) and raise base extension (3).
3. Remove 12 screws (4) from hinge (5) between base extension (3) and base (6).
4. Remove bolt (7), two washers (8), and lever (9) from base extension (3).

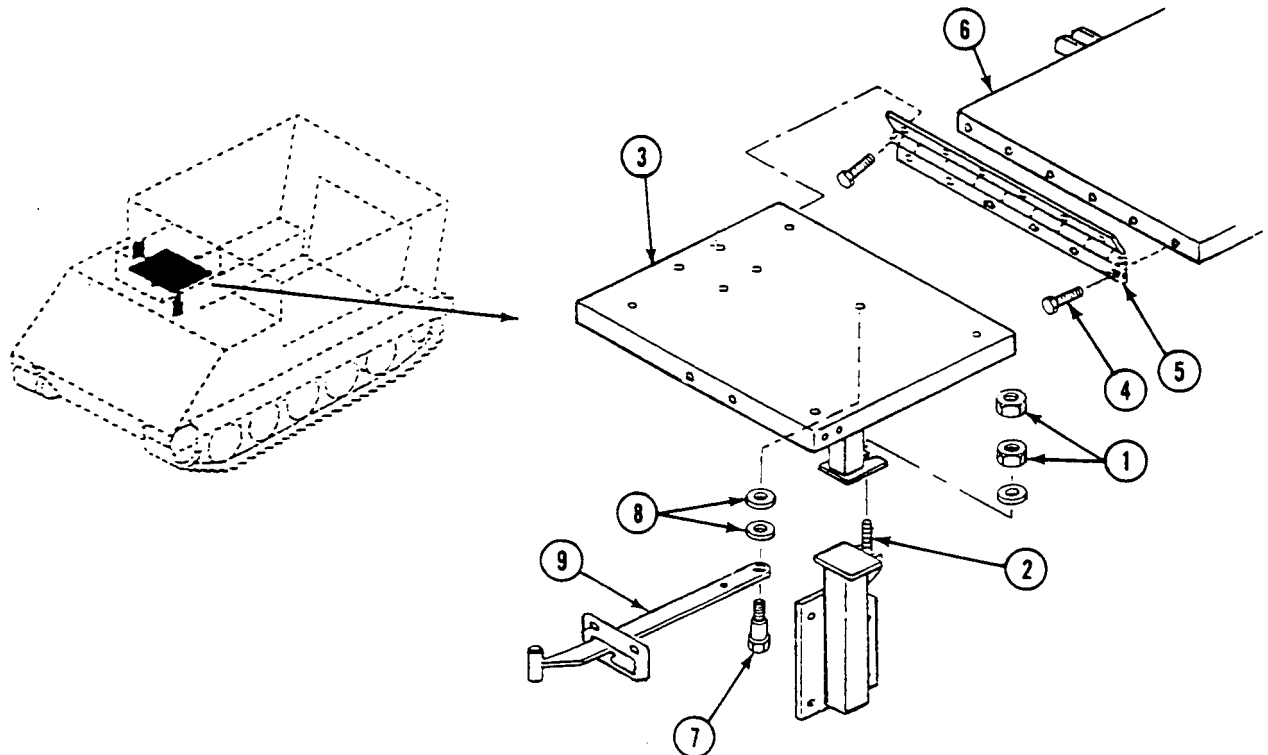

REPLACE RIGHT SIDE BASE EXTENSION (M1068A3 ONLY) — Continued

0623 00

5. Remove two cotter pins (1), headed pins (2), three washers (3), and link (4) from lever (5) and striker (6). Discard cotter pins.
6. Remove lever (5) from guide (7).
7. Remove two screws (8), nuts (9), lockwashers (10), lockwashers (11), washers (12), and guide (7) from base extension (13). Discard lockwashers.
8. Remove four screws (14), lockwashers (15), washers (16), and bracket (17) from base extension (13). Discard lockwashers.
9. Remove two nuts (18), striker (6), and spring (19) from bracket (17).
10. Remove two screws (20), lockwashers (21), washers (22), and plate (23) from base extension (13). Discard lockwashers.

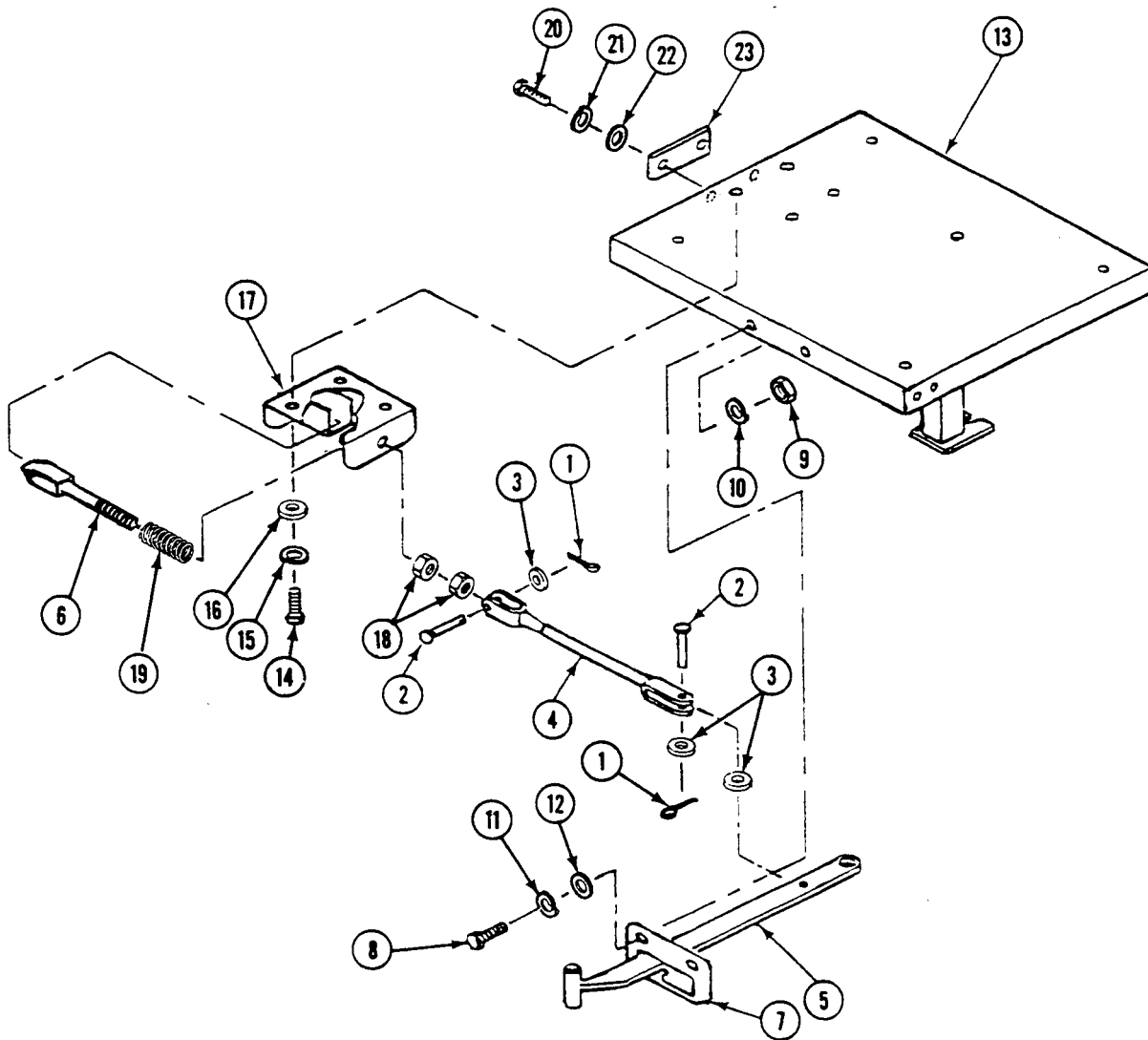

INSTALLATION

1. Install plate (1) on base extension (2) and secure with two screws (3), new lockwashers (4), and washers (5).
2. Install striker (6) and spring (7) in bracket (8) and secure with two nuts (9).
3. Position bracket (8) on base extension (2) and secure with four screws (10), new lockwashers (11), and washers (12).
4. Position guide (13) on base extension (2) and secure with two screws (14), nut (15), new lockwashers (16), new lockwashers (17), and washers (18).
5. Insert lever (19) through guide (13).
6. Install link (20) between lever (19) and striker (6).
7. Secure link (20) to striker (6) with headed pin (21), washer (22), and new cotter pin (23).
8. Secure link (20) to lever (19) with headed pin (24), two washers (25), and new cotter pin (26).
9. Secure lever (19) to base extension (2) with bolt (27) and two washers (28).

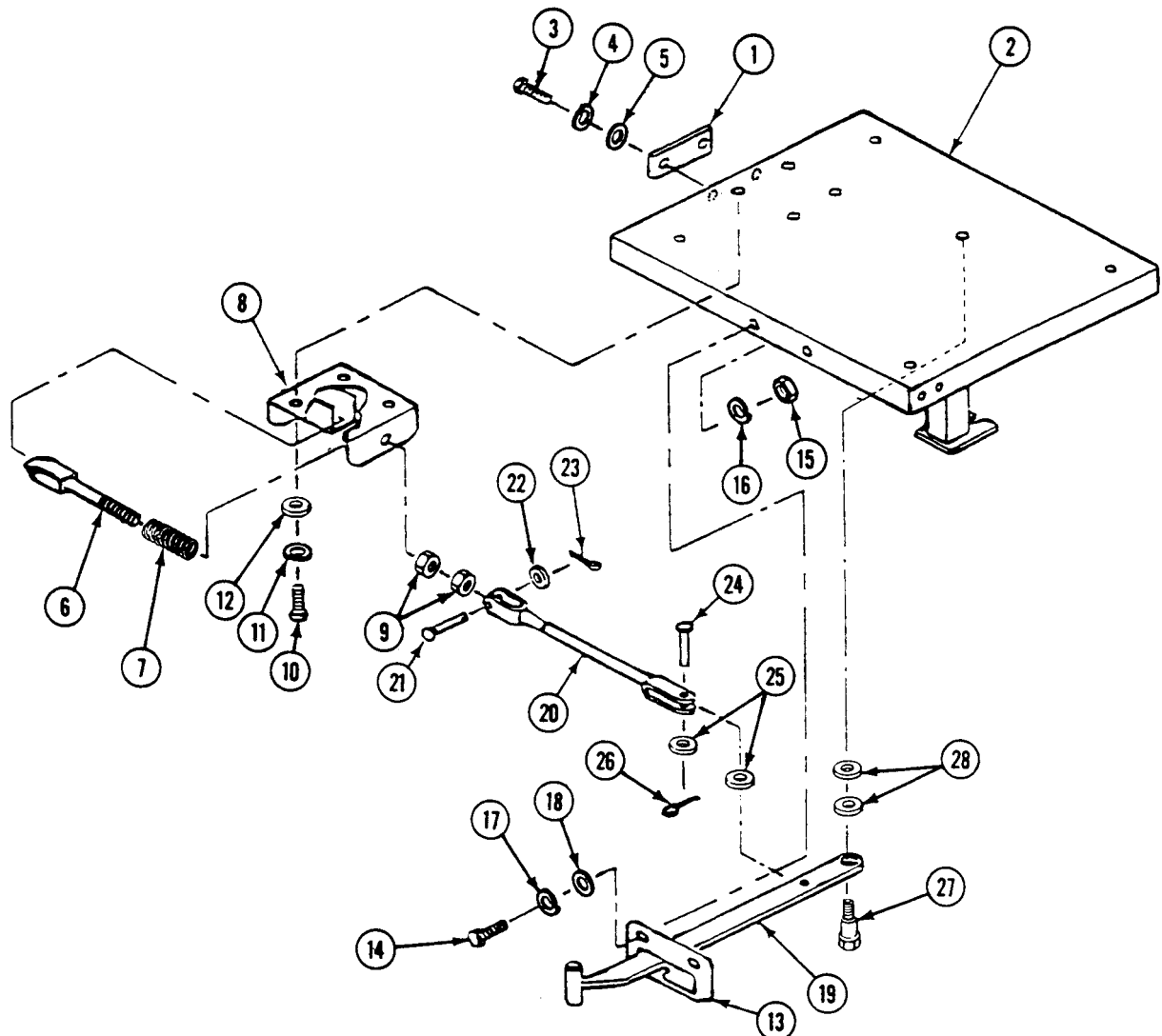

10. Install hinge (1) to base extension (2) and base (3) with 12 screws (4).

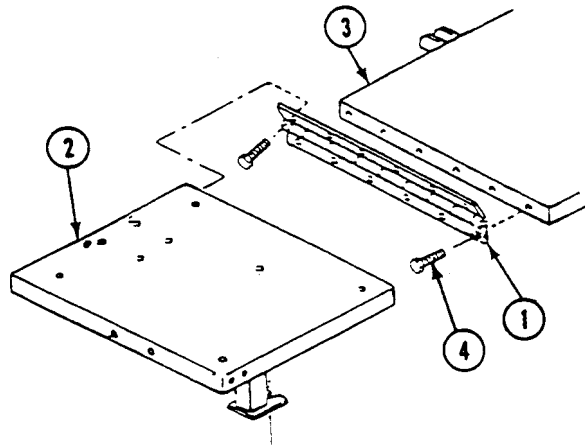

ADJUSTMENT

1. Loosen four screws (5). Lower base extension (2) so that striker (6) latches over hull wall-mounted support (7). Adjust bracket (8) so that end of striker latches over support $3/8$ to $5/8$ inch (10 to 16 mm). Tighten four screws (5).
2. With lever (9) in the lock position, adjust nut (10) until the clearance between nut (10) and bracket (8) is $1/16$ inch (1.6 mm) minimum with striker (6) latched over support (7). Then hold nut (10) and tighten jamnut (11) against nut (10).

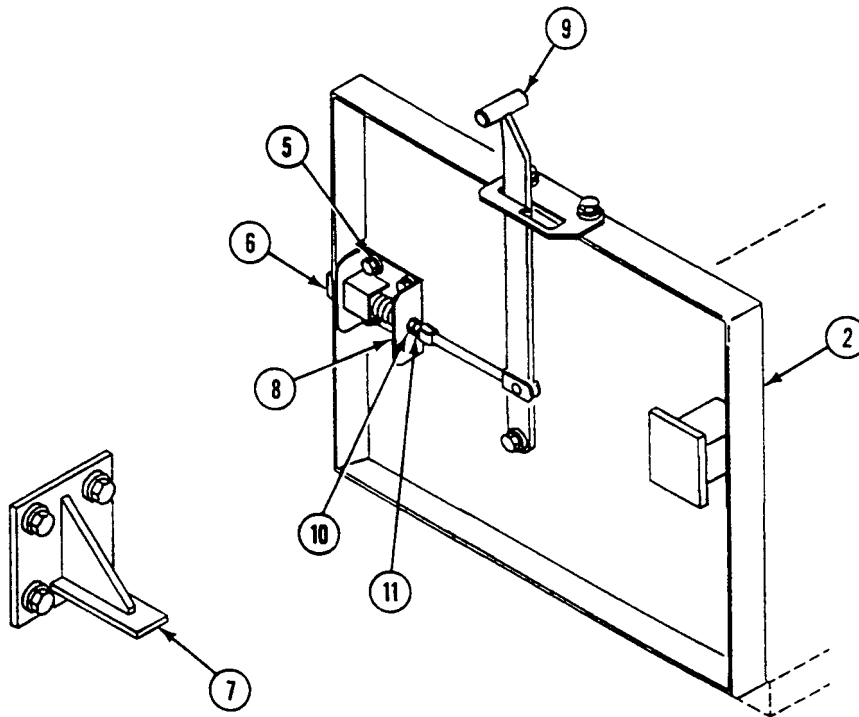

END OF TASK

REPLACE RIGHT SIDE BASE EXTENSION SUPPORTS (M1068A3 ONLY)

0624 00

THIS WORK PACKAGE COVERS:

Removal (page 0624 00-1).
 Installation (page 0624 00-3).

INITIAL SETUP:

Maintenance Level

Unit

Personnel Required

Unit Mechanic

Tools and Special Tools

General Mechanic's Tool Kit (WP 0926 00, Item 65)

References

See your -10

Materials/Parts

Cotter pin
 Lockwasher (8)
 Lockwasher (4)

Equipment Condition

Engine stopped (see your -10)
 Carrier blocked (see your -10)
 Base extension raised (see your -10)
 Batteries removed (WP 0347 00)

REMOVAL

WARNING

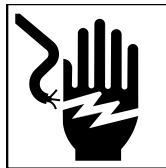

Battery posts and cables touched by metal objects can short circuit and burn you. Use caution when you work with tools or other metal objects. Do not wear jewelry when you work on electrical system.

REPLACE RIGHT SIDE BASE EXTENSION SUPPORTS (M1068A3 ONLY) — Continued

0624 00

1. Remove four screws (1), nuts (2), eight washers (3), lockwashers (4), and support (5) from battery box (6). Discard lockwashers.
2. Remove cotter pin (7), washer (8), headed pin (9), and bolt (10) from support (5). Discard cotter pin.
3. Remove two nuts (11) and washers (12) from bolt (10).
4. Lift base extension (13) to upright position.
5. Remove four screws (14), lockwashers (15), washers (16), and support (17) from right hull wall.

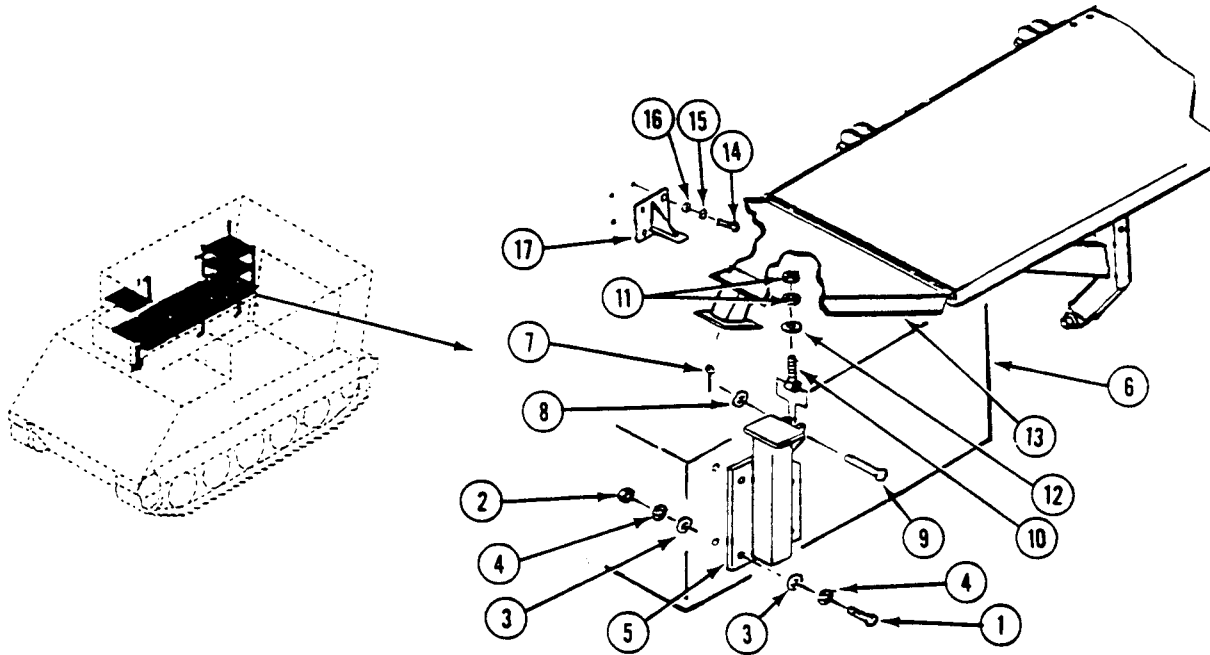

INSTALLATION

1. Install four screws (1), new lockwashers (2), washers (3), and support (4) on right hull wall.
2. Lower base extension (5) onto support (4).
3. Position bolt (6) in support (7) and secure with headed pin (8), washer (9), and new cotter pin (10).
4. Install washer (11) and two nuts (12) on bolt (6).
5. Position support (7) on battery box (13) and secure with four screws (14), nuts (15), eight washers (16), and new lockwashers (17).

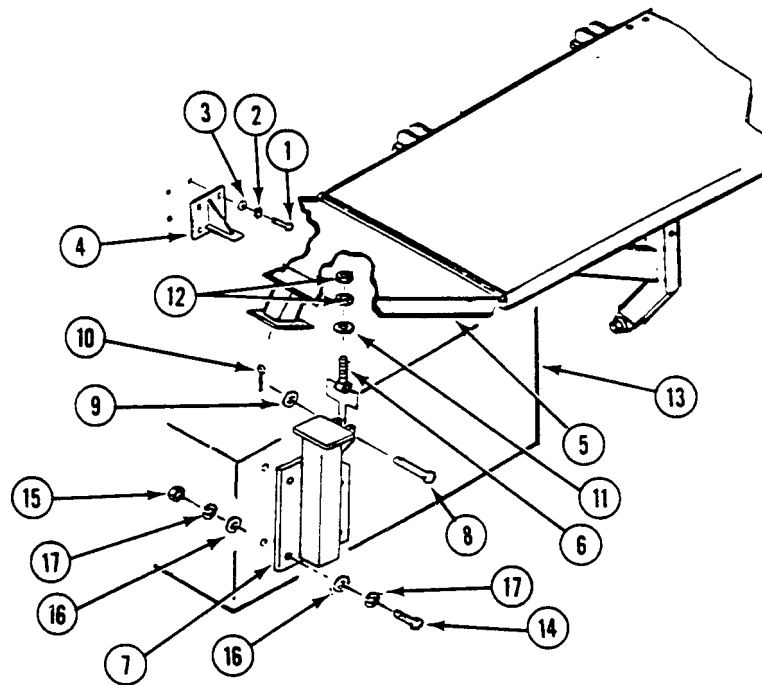
**FOLLOW-THROUGH STEPS**

1. Install batteries (WP 0347 00).
2. Lower base extension (see your -10).

END OF TASK

REPLACE/REPAIR ANTENNA MAST BRACKET ASSEMBLY, TAILLIGHT WIRING HARNESS, AND BRACKET (M1068A3 ONLY)

0625 00

THIS WORK PACKAGE COVERS:

- Removal (page 0625 00-1).
- Installation (page 0625 00-7).

INITIAL SETUP:

Maintenance Level
Unit

Personnel Required
Unit Mechanic

Tools and Special Tools

- General Mechanic's Tool Kit (WP 0926 00, Item 65)
- Drill Set (WP 0926 00, Item 18)
- Portable Electric Drill (WP 0926 00, Item 20)
- Hand Blind Riveter (WP 0926 00, Item 44)

References

- See your -10
- TM 11-7010-256-12&P

Materials/Parts

- Adhesive (WP 0928 00, Item 4)
- Cleaning Compound (WP 0928 00, Item 19)
- Wiping rag (WP 0928 00, Item 65)
- Cotter pin
- Grommet (2)
- Locknut (2)
- Lockwasher
- Lockwasher (4)

Equipment Condition

- Engine stopped (see your -10)
- Carrier blocked (see your -10)
- Antenna mast removed (TM 11-7010-256-12&P)
- All external power disconnected (TM 11-7010-256-12&P)
- Battery ground lead disconnected (WP 0338 00)

REMOVAL

1. Remove securing pad (1) from bracket (2).

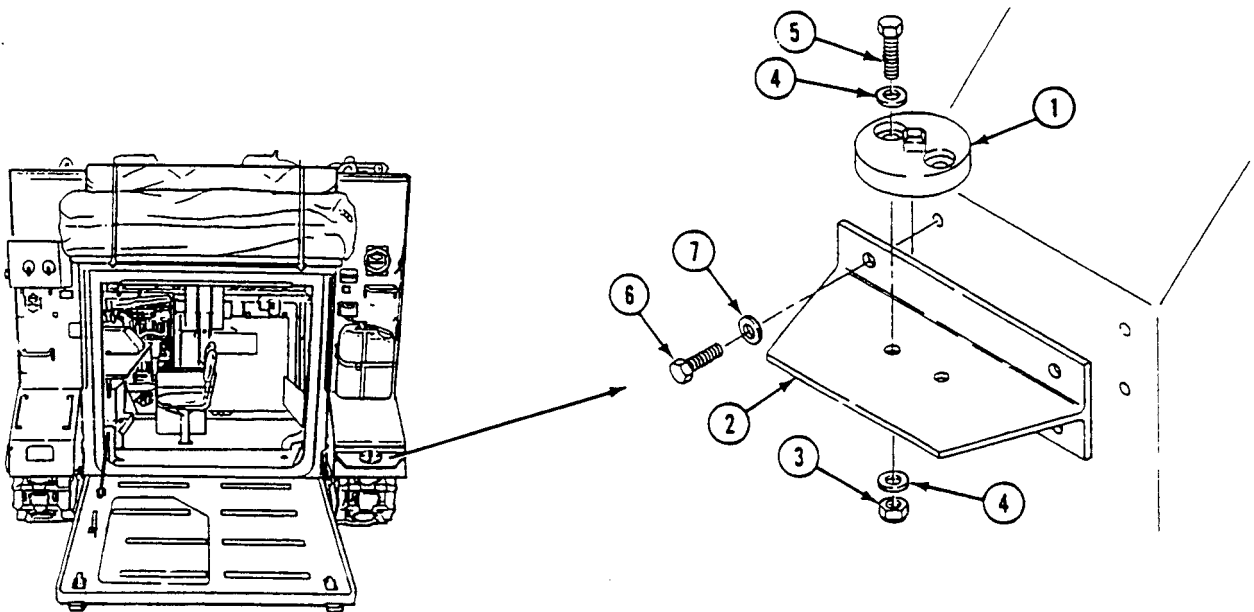

- a. Remove two locknuts (3), four washers (4), screws (5), and securing pad (1) from bracket (2). Discard locknuts.

REPLACE/REPAIR ANTENNA MAST BRACKET ASSEMBLY, TAILLIGHT WIRING HARNESS, AND BRACKET (M1068A3 ONLY) — Continued

0625 00

2. Remove bracket (2) from fender.
 - a. Remove four screws (6), washers (7), and bracket (2) from fender.

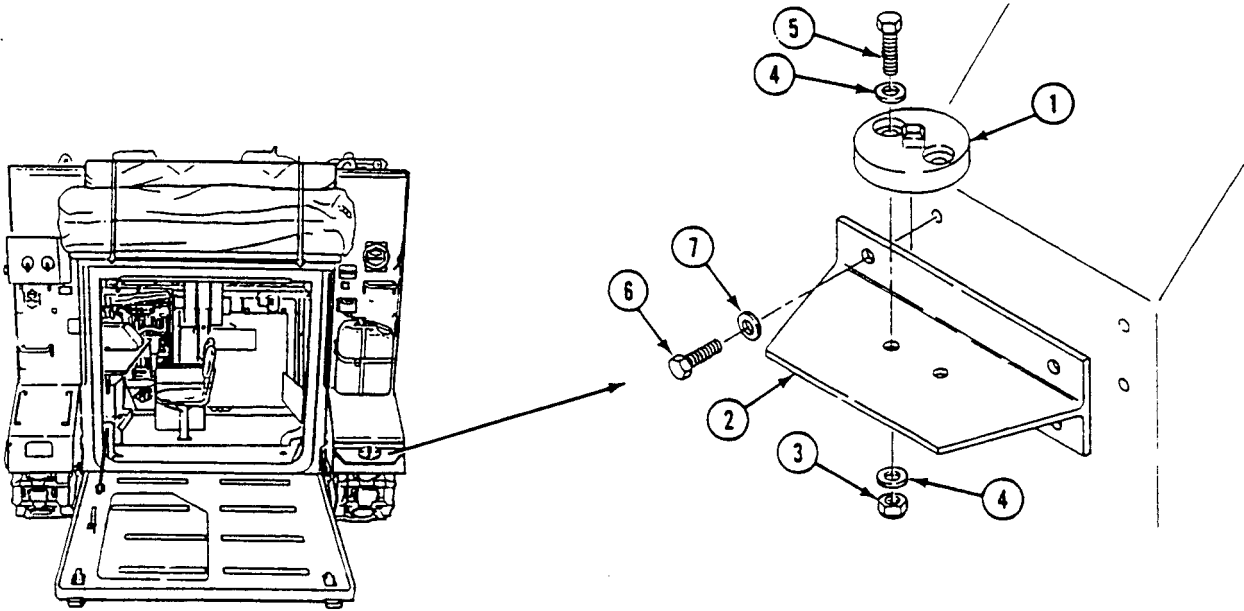

REPLACE/REPAIR ANTENNA MAST BRACKET ASSEMBLY, TAILLIGHT WIRING HARNESS, AND BRACKET (M1068A3 ONLY) — Continued

0625 00

3. Remove two screws (1), washers (2), and guard (3) from hull.

NOTE

There are two sets of circuit 23 and 24 leads. One set connects inside the vehicle and the other set connects outside the vehicle.

4. Disconnect circuits 23 and 24 leads (4)(5) from right taillight (6).
5. Disconnect taillight wiring harness (7) inside vehicle.
 - a. Remove screw (8), lockwasher (9), and clamp (10) securing taillight wiring harness (7) to rear of hull. Discard lockwasher.

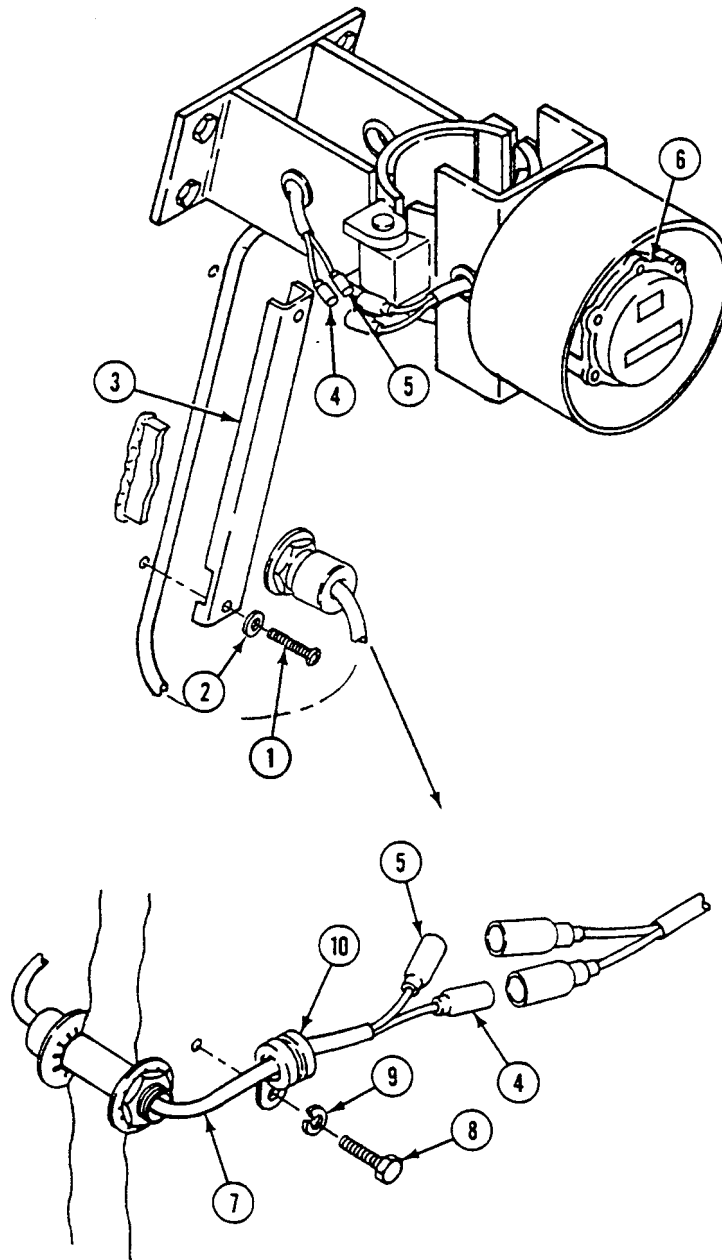

REPLACE/REPAIR ANTENNA MAST BRACKET ASSEMBLY, TAILLIGHT WIRING HARNESS, AND BRACKET (M1068A3 ONLY) — Continued

0625 00

6. Disconnect leads circuit 23 (4) and circuit 24 (5) connectors.
 - a. Slide two shells (11) up connectors (4)(5).
 - b. Remove two washers (12) from connectors (4)(5).
 - c. Remove two shells (11) off connectors (4)(5).

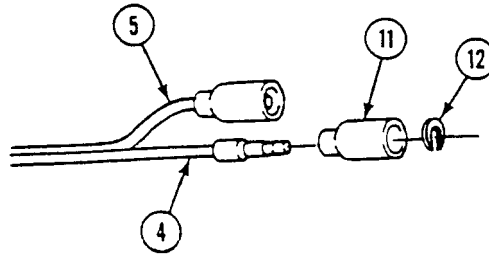

7. Remove taillight wiring harness (1) with shield from hull.
 - a. Remove taillight wiring harness (1) from two grommets (2)(3) in antenna mast bracket (4).
 - b. Remove nut (5) and lockwasher (6) from shield (7) containing taillight wiring harness (1). Pull wiring harness and shield toward the rear and through the mounting hole in the vehicle.
8. Remove two grommets (2)(3) from antenna mast bracket (4). Discard grommets.

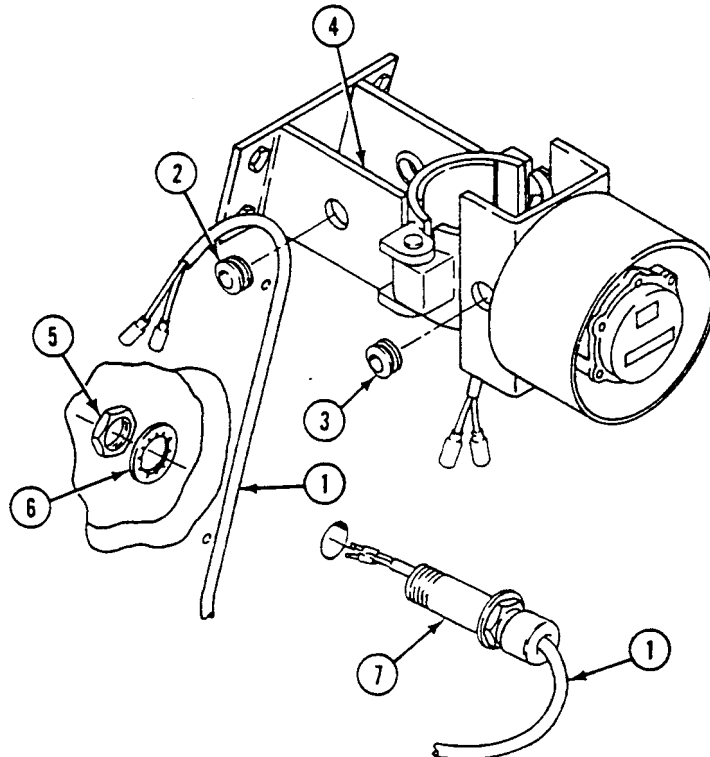

**REPLACE/REPAIR ANTENNA MAST BRACKET ASSEMBLY, TAILLIGHT WIRING
HARNES, AND BRACKET (M1068A3 ONLY) — Continued**

0625 00

9. Remove taillight (8).
 - a. Remove two screws (9), washers (10), and taillight from antenna mast bracket (4).

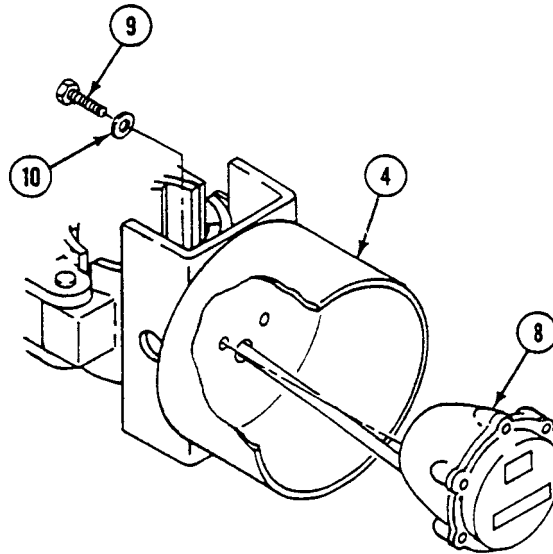
**NOTE****If catches are damaged, do Step 10b.**

10. Unlatch two catches (11) on antenna mast bracket (4).
 - a. Remove four screws (12), lockwashers (13), and two strikes (14) from antenna mast bracket (4). Check catches for damage. Discard lockwashers.
 - b. Drill out four rivets (15) securing two catches (11) to bracket (4). Remove and discard catches and rivets.

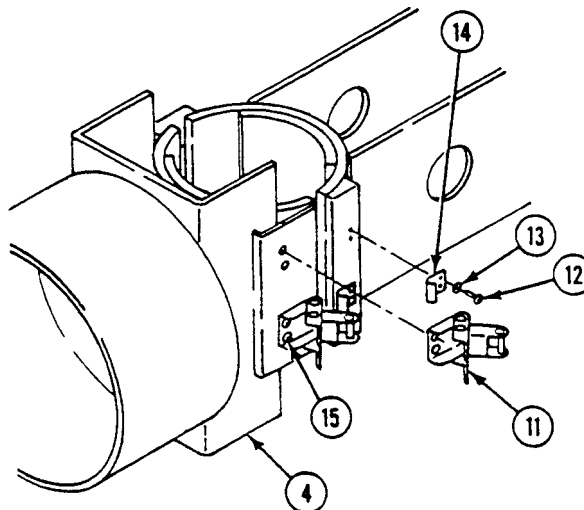

REPLACE/REPAIR ANTENNA MAST BRACKET ASSEMBLY, TAILLIGHT WIRING HARNESS, AND BRACKET (M1068A3 ONLY) — Continued

0625 00

11. Remove hinged portion of antenna mast bracket (1).
 - a. Remove cotter pin (2), washer (3), hinge pin (4), and the front portion of antenna mast bracket (1). Discard cotter pin.

12. Remove four screws (5), washers (6), and that portion of the antenna mast bracket (7) against the right rear hull.

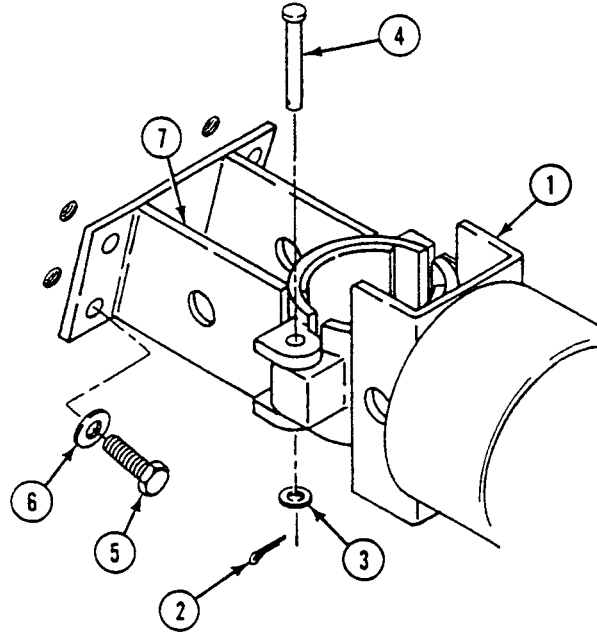

13. Replace rubber pads (8)(9) on antenna mast brackets (1)(7).
 - a. If damaged, remove rubber pads (8)(9) from brackets (1)(7). Clean off all excess adhesive. Use cleaning compound and wiping rags.

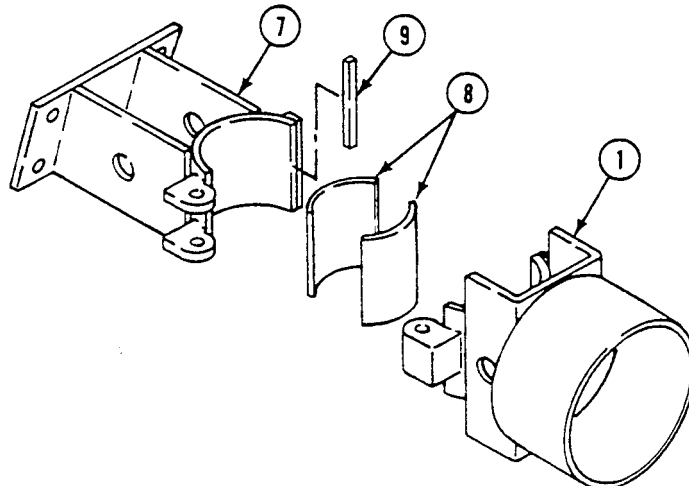

**REPLACE/REPAIR ANTENNA MAST BRACKET ASSEMBLY, TAILLIGHT WIRING
HARNESS, AND BRACKET (M1068A3 ONLY) — Continued**

0625 00

INSTALLATION**NOTE****Replace damaged rubber pads.**

1. Install new rubber pads (8)(9) on antenna mast brackets (1)(7).
 - a. Apply a thin, even coat of adhesive to the rubber pad surfaces (8)(9). Allow to dry 20 to 40 minutes. Apply a thin, even coat of adhesive to the inside of the brackets (1)(7). Allow to dry 30 to 120 seconds. Press the surfaces of the rubber pads (8) and brackets (1)(7) with the adhesive on them together firmly.

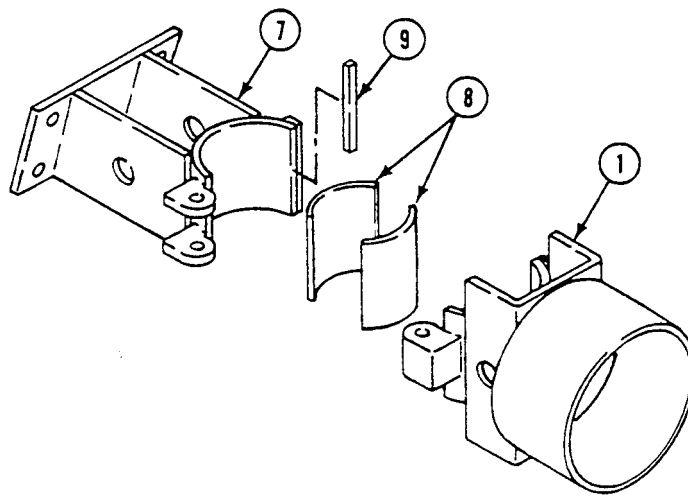

**REPLACE/REPAIR ANTENNA MAST BRACKET ASSEMBLY, TAILLIGHT WIRING
HARNES, AND BRACKET (M1068A3 ONLY) — Continued**

0625 00

2. Install stationary part of antenna mast (1) to right rear of hull.
 - a. Install antenna mast (1), four washers (2), and screws (3) to right rear of hull.
3. Install hinged portion of antenna mast (4).
 - a. Install antenna mast (4), hinge pin (5), washer (6), and new cotter pin (7).

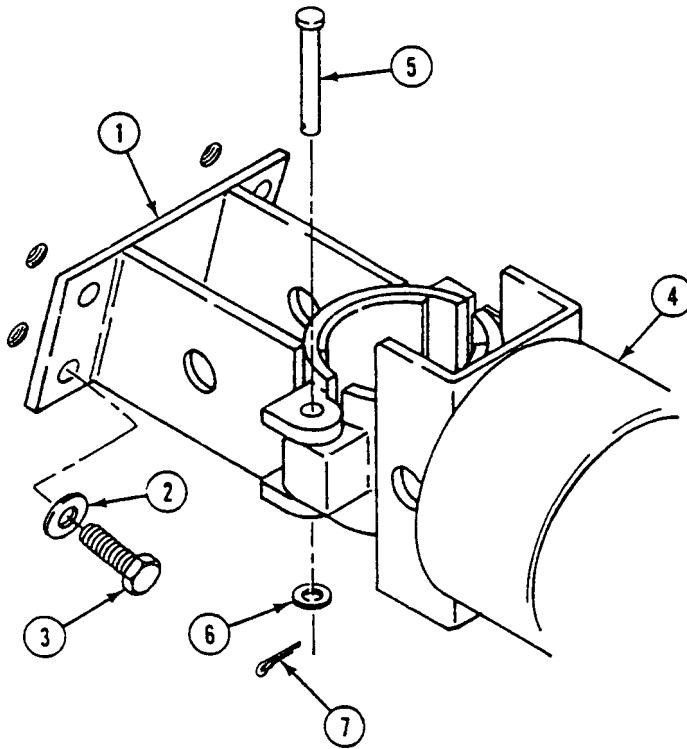

NOTE

If catches were removed in Step 10b, do Step 4a.

4. Latch two catches (8) on antenna mast brackets (1)(4).
 - a. Install two catches (8) and four rivets (9) to antenna bracket (1).
 - b. Install two strikes (10), four new lockwashers (11), and screws (12) on antenna mast (4). Tighten screws securely.

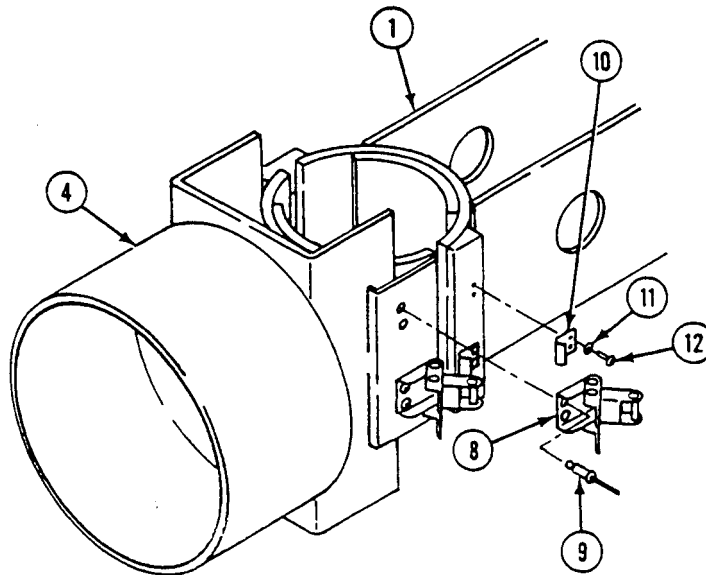

REPLACE/REPAIR ANTENNA MAST BRACKET ASSEMBLY, TAILLIGHT WIRING HARNESS, AND BRACKET (M1068A3 ONLY) — Continued

0625 00

5. Install taillight (1) to antenna mast bracket (2).
 - a. Install taillight (1), two washers (3), and screws (4) on antenna mast bracket (2). Tighten screws securely.

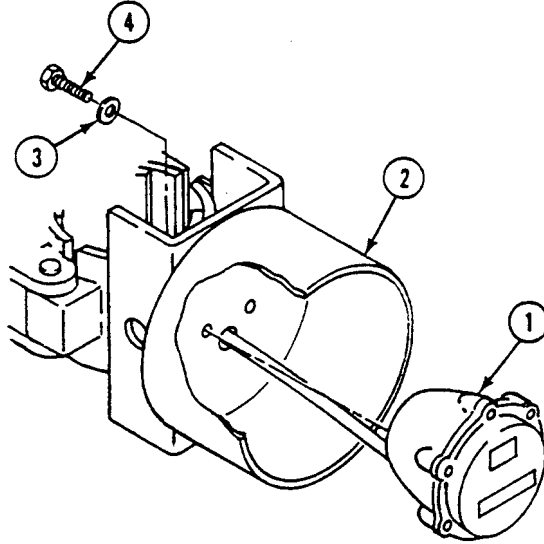

6. Install two new grommets (5)(6) in antenna mast (2).

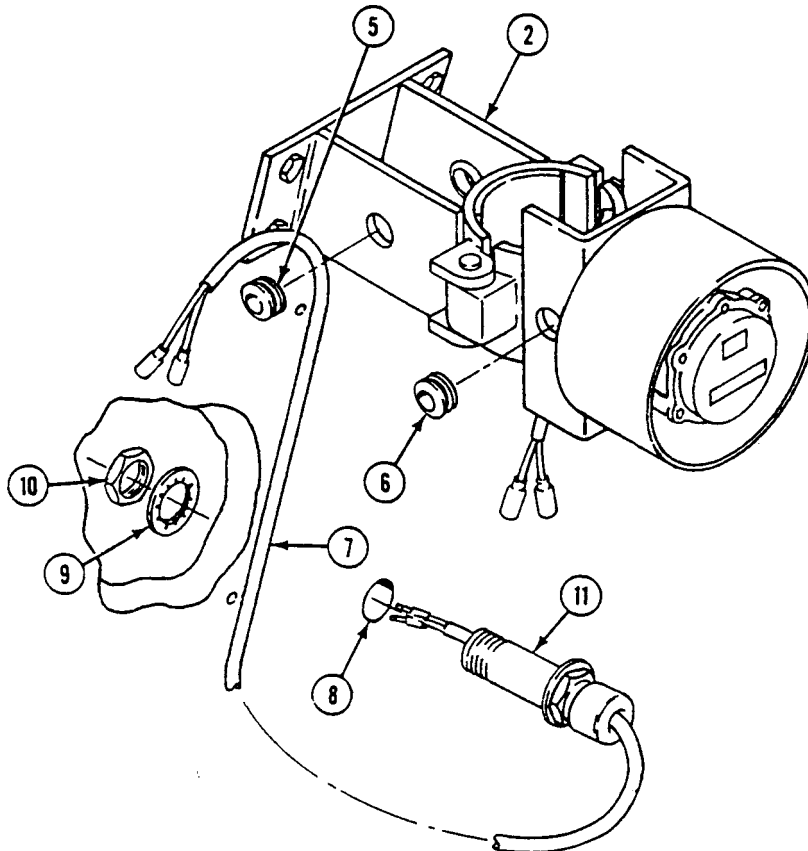

**REPLACE/REPAIR ANTENNA MAST BRACKET ASSEMBLY, TAILLIGHT WIRING
HARNESS, AND BRACKET (M1068A3 ONLY) — Continued**

0625 00

7. Install taillight wiring harness (7) with shield through mounting hole (8) in hull.
 - a. Install lockwasher (9) and nut (10) over circuit leads and onto shield (11). Tighten nut securely on shield.
 - b. Install the other end of wiring harness (7) through grommet (5) on antenna mast bracket (2). Route wires and connectors for taillight through grommet (6).

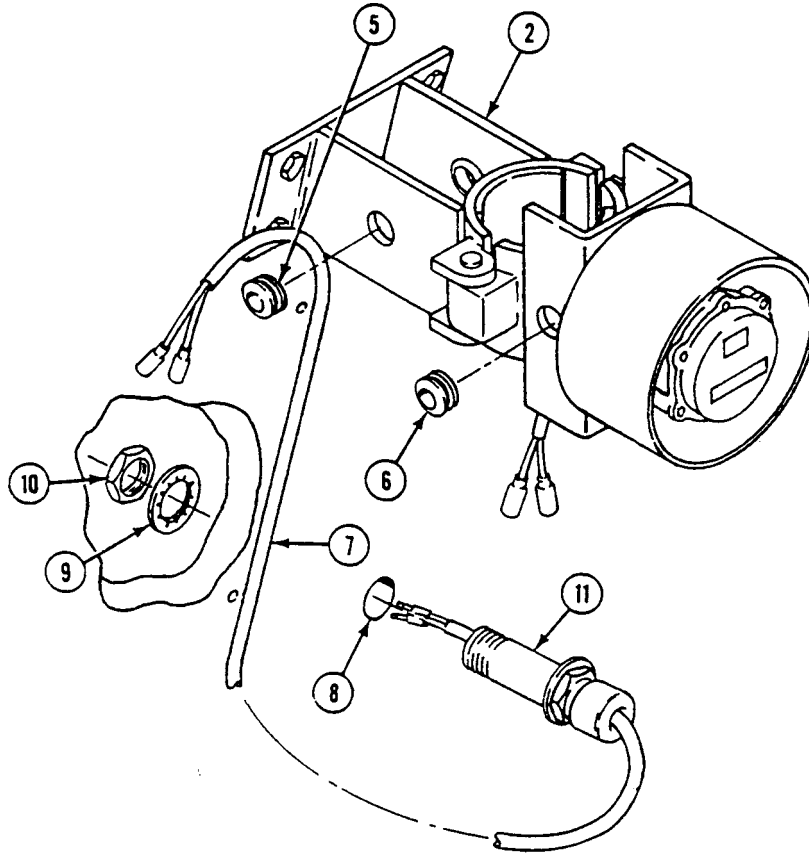

**REPLACE/REPAIR ANTENNA MAST BRACKET ASSEMBLY, TAILLIGHT WIRING
HARNES, AND BRACKET (M1068A3 ONLY) — Continued**

0625 00

NOTE

There are two circuit leads 23 and 24. One set connects inside the vehicle and one set connects outside the vehicle.

8. Install shells (1) on wiring harness (2) inside of vehicle.
 - a. Install shells (1) on connectors (3)(4).
 - b. Install washers (5) for holding pins in place on connectors (3)(4).
 - c. Slide shells up connectors (3)(4).

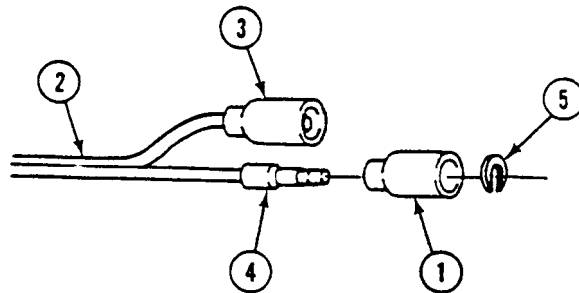

9. Connect taillight wiring harness (2) inside vehicle.
 - a. Connect circuit lead 23 (6) and circuit lead 24 (7) to main rear wiring harness (8).
 - b. Install taillight wiring harness (2), clamp (9), new lockwasher (10) and screw (11) to the rear of hull.

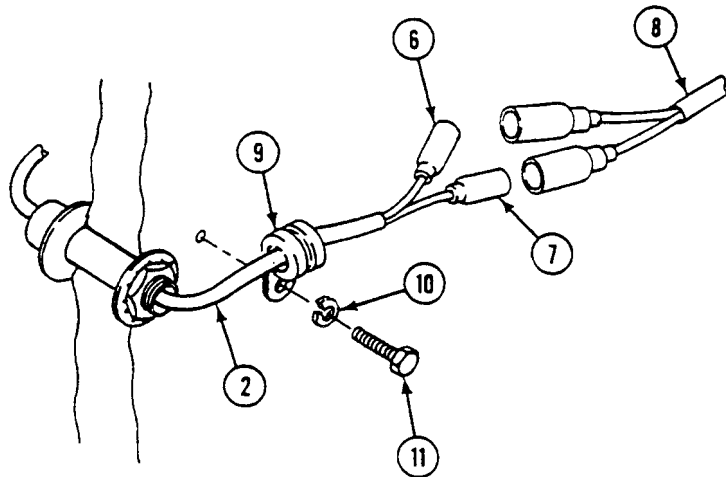

REPLACE/REPAIR ANTENNA MAST BRACKET ASSEMBLY, TAILLIGHT WIRING HARNESS, AND BRACKET (M1068A3 ONLY) — Continued

0625 00

10. Connect circuit leads 23 (6) and 24 (7) to taillight leads.

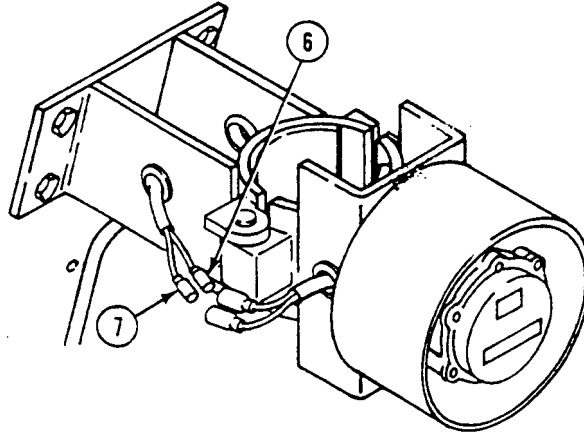

11. Install guard (1), washers (2), and screws (3) on hull.

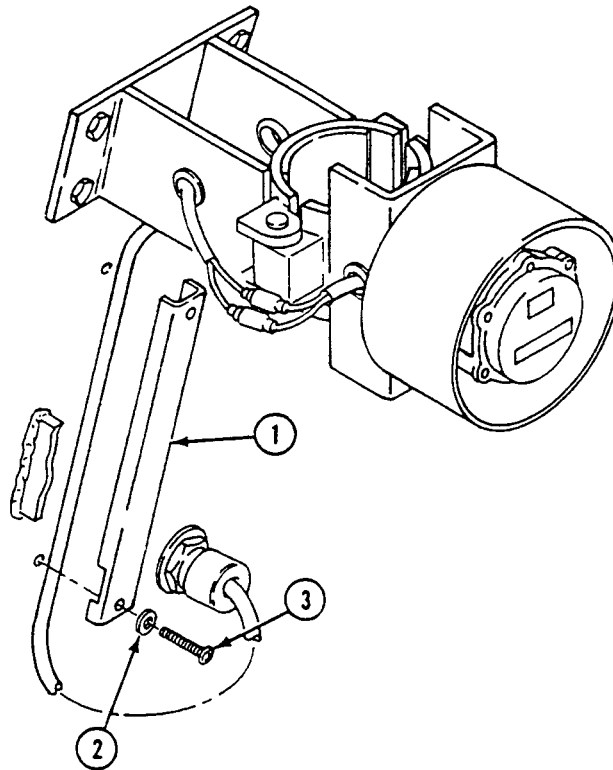

REPLACE/REPAIR ANTENNA MAST BRACKET ASSEMBLY, TAILLIGHT WIRING HARNESS, AND BRACKET (M1068A3 ONLY) — Continued

0625 00

12. Install bracket (4), four washers (5), and screws (6) on fender.
13. Install securing pad (7), two screws (8), four washers (9), and new locknuts (10) on bracket (4).

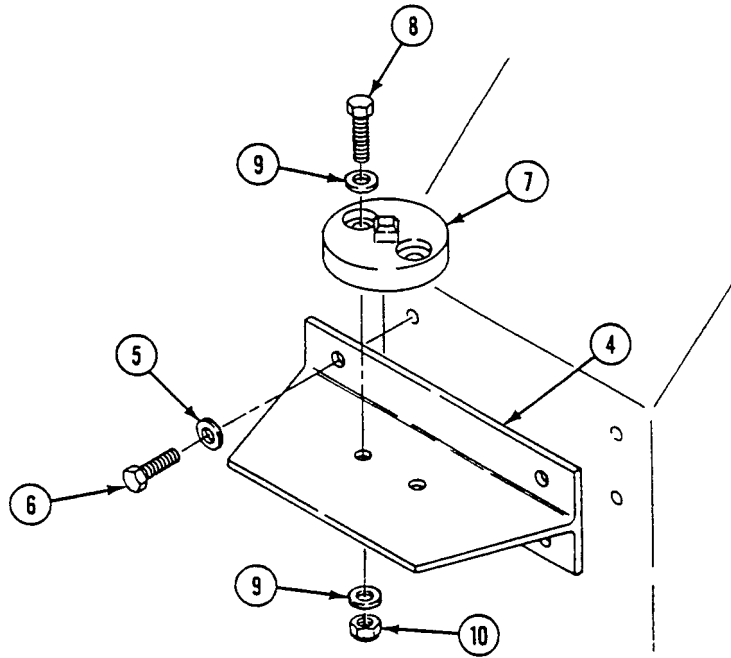

FOLLOW-THROUGH STEPS

1. Connect battery ground lead (WP 0338 00).

END OF TASK

REPLACE REAR EXTERNAL STOWAGE FRAME (M1068A3 ONLY)

0626 00

THIS WORK PACKAGE COVERS:

Removal (page 0626 00-1).
 Installation (page 0626 00-2).

INITIAL SETUP:

Maintenance Level

Unit

References

See your -10

Tools and Special Tools

General Mechanic's Tool Kit (WP 0926 00, Item 65)

Equipment Condition

Engine stopped (see your -10)

Carrier blocked (see your -10)

Materials/Parts

Cotter pin (2)

Locknut (4)

Personnel Required

Unit Mechanic

Helper (H)

REMOVAL

1. Loosen two straps (1) and remove stowed equipment from rear external stowage frame (2).
2. Remove two straps (1) from loops on hull rear plate and frame (2).
3. Remove two cotter pins (3), shouldered pins (4), four washers (5), and rear external stowage frame (2) from two mounts (6). Discard cotter pins. Have helper hold up one side.
4. Remove four screws (7), washers (8), and two mounts (6) from hull rear plate.
5. Remove four locknuts (9), screws (10), eight washers (11), and pad (12) from rear external stowage frame (2). Discard locknuts.
6. Remove six screws (13), washers (14), lockwashers (15), and pad (16) from rear external stowage frame (2). Discard lockwashers.

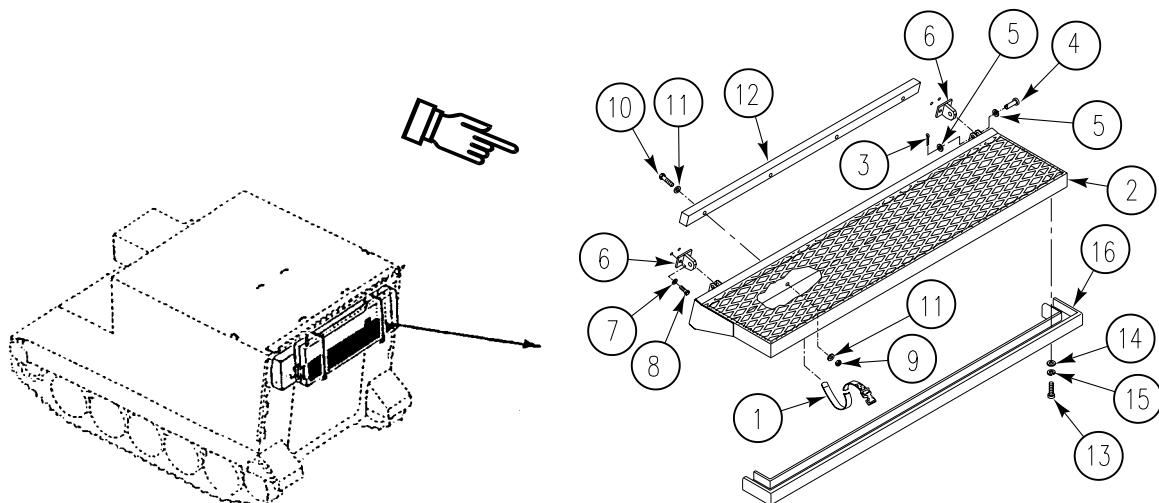

INSTALLATION

1. Install pad (1), eight washers (2), four screws (3), and new locknuts (4) on rear external stowage frame (5).
2. Install two mounts (6), four washers (7), and screws (8) on hull rear plate.
3. Install rear external stowage frame (5), four washers (9), two shouldered pins (10), and new cotter pins (11) on two mounts (6). Have helper hold up one side.
4. Connect two straps assemblies (12) to two loops on hull rear plate and frame (5).
5. Stow equipment on rear external stowage frame (5) with two straps (12).
6. Install pad (13) six washers (14), new lockwashers (15), and screws (16) to rear external stowage frame (5).

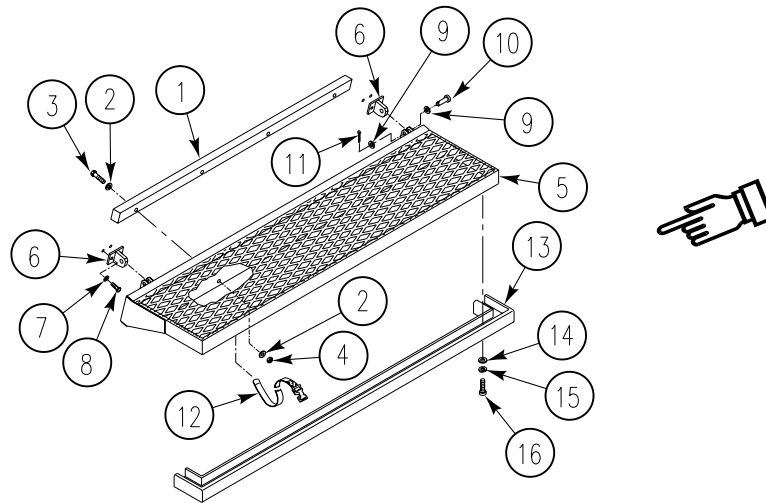
**END OF TASK**

REPLACE STOWAGE BRACKETS FOR W1, W2, AND NATO SLAVE CABLES (M1068A3 AND M577A3)

0626 01

THIS WORK PACKAGE COVERS:

Removal (page 0626 01-1).
 Installation (page 0626 01-2).

INITIAL SETUP:

Maintenance Level

Unit

References

See your -10

Tools and Special Tools

General Mechanic's Tool Kit (WP 0926 00, Item 65)

Equipment Condition

Engine stopped (see your -10)

Materials/Parts

Lockwasher (3)

Carrier blocked (see your -10)

Personnel Required

Unit Mechanic

All cables removed from brackets (see your -10)

REMOVAL

NOTE

There are two stowage brackets per location. Two stowage brackets secure the stowed NATO slave cables and the other two stowage brackets secure the stowed W1 and W2 power distribution cables. They are all removed and installed the same way. Only one is shown.

1. Remove three screws (3), washers (1), lockwashers (2), and bracket (4) from vehicle.

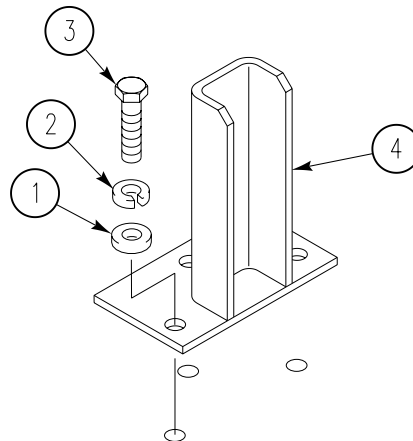
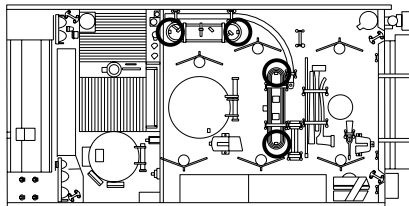

REPLACE STOWAGE BRACKETS FOR W1, W2, AND NATO SLAVE CABLES (M1068A3 AND M577A3) — Continued

0626 01

INSTALLATION

1. Install bracket (4), three lockwashers (2), washers (1), and screws (3) on vehicle.

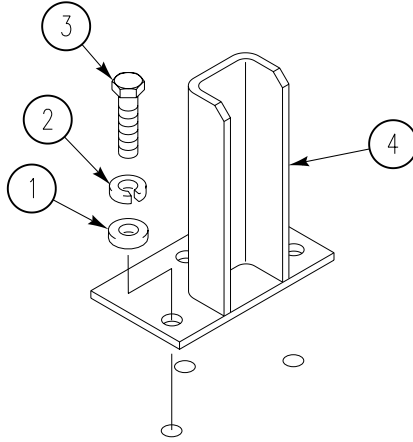
**END OF TASK**

INDEX

<u>Subject</u>	<u>WP Sequence No.-Page No.</u>
5.0 KW Auxiliary Power Unit M577A3 and M1068A3 Replacement.....	0675 00-1
A	
A.C. Power Extension Box A7 (M1068A3) Replace.....	0815 00-1
A1 Power Control Enclosure Assembly M1068A3 Replacement.....	0826 00-1
A4 Power Entry Box Assembly M1068A3 Replacement.....	0832 00-1
AC Cable Assembly W252 M1068A3 Replacement.....	0857 00-1
AC Light Cable (W11) M1068A3 Replacement.....	0845 00-1
AC Power Extension Box A19 M1068A3 Replacement.....	0822 00-1
AC Power Extension Box A6 M1068A3 Replacement.....	0834 00-1
AC Power Extension Box A6 and DC Power Extension Box A9 and Mount M1068A3 Replacement.....	0834 00-1
AC Power Extension Cable (W7) M1068A3 Replacement.....	0842 00-1
AC Power Extension Cable (W8) (M1068A3) Replace.....	0843 00-1
Accelerator Linkage Adjust.....	0214 00-1
Accelerator Pedal Lower Replacement.....	0215 00-1

INDEX, cont'd

<u>Subject</u>	<u>WP Sequence No.-Page No.</u>
Accelerator Pedal Assembly	
Upper	
Replacement.....	0216 00-1
Access cover	
Battery box	
M577A3 and M1068A3	
Repair.....	0352 00-1
Fan drive pulley	
Removal/installation.....	0440 00-1
Hull front	
Replacement.....	0449 00-1
Power plant bottom	
Replacement.....	0450 00-1
Access Covers	
Fuel Tank	
M577A3 and M1068A3	
Replacement.....	0188 00-1
Access covers	
Fuel tank	
All except M577A3 and M1068A3	
Replacement.....	0187 00-1
Access door	
Radiator	
Replacement.....	0469 00-1
Turbine	
M58	
Replacement.....	0485 00-1
Access door gasket	
Turbine	
M58	
Replacement.....	0486 00-1
Access door hinges	
Turbine	
M58	
Replacement.....	0487 00-1
Access panel	
Driver's power plant	
Replacement.....	0441 00-1
Access Plate	
Adapter	
Smoke Generator (M1059A3)	
Replace.....	0766 00-1

INDEX, cont'd

<u>Subject</u>	<u>WP Sequence No.-Page No.</u>
Adapter	
Speedometer	
Replace.....	0860 00-1
Tachometer	
Replace.....	0863 00-1
Adjuster	
Track tension	
Replacement.....	0419 00-1
Admittance buzzer and switch	
M577A3 and M1068A3	
Replacement.....	0334 00-1
Air Box Heater	
IgnitionWire	
Replacement.....	0204 00-1
Wiring Harness	
Replacement.....	0205 00-1
Air Box Heater Lower Fuel Line	
Replacement.....	0206 00-1
Air Box Ignition Coil	
Replacement.....	0208 00-1
Air box pressure transducer	
Replacement.....	0327 00-1
Air Cleaner	
Elbow	
Replacement.....	0168 00-1
Filter Element	
Service.....	0167 00-1
Replacement.....	0168 00-1
Air cleaner	
Restriction indicator	
Replace.....	0171 00-1
Restriction indicator hose	
Replace.....	0172 00-1
Air Cleaner Assembly	
Replace	0169 00-1
Air Cleaner Retainer	
Repair	0170 00-1
Air Compressor	
Electrical Cable Assembly	
M1059A3	
Replacement.....	0758 00-1

INDEX, cont'd

<u>Subject</u>	<u>WP Sequence No.-Page No.</u>
Air Compressor Assembly (M1059A3 Only)	
Replace.....	0762 00-1
Air Hose	
Adapter Access Plate to Cover Assembly Smoke Generator (M1059A3)	
Replace.....	0768 00-1
Compressor Reservoir to Access Plate Smoke Generator (M1059A3)	
Replace.....	0767 00-1
Air intake	
Elbow	
Replace.....	0173 00-1
Air Intake and Exhaust Pipes	
Heater	
Replacement.....	0683 00-1
Air Intake elbow and hose	
Grill	
Replace.....	0174 00-1
Air Intake Pipes, Heater	
All Except M1064A3	
Replacement.....	0682 00-1
Air Purifier and Frame	
NBC	
M58	
Replacement.....	0914 00-1
Air purifier and frame	
M13	
M1068A3 only	
Replace.....	0779 00-1
Air Separator	
Coolant	
Replacement.....	0236 00-1
Air ventilator	
Rear compartment	
Replacement.....	0454 00-1
Alarm Kit, Automatic	
Chemical Agent	
M113A3	
Installation/Removal	0918 00-1

INDEX, cont'd

<u>Subject</u>	<u>WP Sequence No.-Page No.</u>
Ammunition Rack	
Horizontal	
M1064A3	
Replacement.....	0606 00-1
Ammunition rack	
Horizontal	
M1064A3	
Repair.....	0607 00-1
Vertical	
M1064A3	
Replacement.....	0608 00-1
Amplifier	
Intercom	
M58	
Replace.....	0888 00-1
AN/VAS-5 Driver's Night Vision Enhancer Sensor Set Assembly Adapter (DVE)	
M58	
Replacement.....	0866 05-1
AN/VAS-5 Driver's Vision Enhancer Stowage Bracket	
M58	
Replacement.....	0866 03-1
AN/VVS-2	
Driver's Night Vision Stowage	
All Except M58	
Replacement.....	0572 00-1
AN/VVS-2 driver's night vision guard	
Driver's Hatch	
All Except M58	
Replacement.....	0536 00-1
(AN/VVS-2) Driver's night vision mount	
All Except M58	
Replacement.....	0537 00-1
Anchor	
Torsion bar	
Replacement.....	0414 00-1
Antenna	
AS3916/VRC	
M58	
Replacement.....	0887 00-1
Guard	
Replacement.....	0575 00-1

INDEX, cont'd

<u>Subject</u>	<u>WP Sequence No.-Page No.</u>
Mast Bracket Assembly	
M1068A3	
Repair.....	0625 00-1
Replacement.....	0625 00-1
Support	
M58	
Replacement.....	0602 00-1
APIU Rack	
Mount and Bracket	
M1068A3	
Replacement.....	0813 00-1
Arm	
Road wheel support	
Replacement.....	0415 00-1
Arm assembly	
Idler wheel	
Replacement.....	0417 00-1
Armor	
Front	
M113A3	
Replacement.....	0749 00-1
Shields, Commander's Cupola	
M113A3 and M1064A3	
Replacement.....	0747 00-1
Smoke Generator (M1059A3)	
Replace.....	0771 00-1
Armor Kit	
M113A3	
Installation.....	0748 00-1
Mine	
M113A3	
Installation/Removal	0752 00-1
Armor plate	
Left front	
Replacement.....	0447 00-1
Right front	
Replacement.....	0448 00-1
AS3916/VRC Antenna	
M58	
Replacement.....	0887 00-1

INDEX, cont'd

<u>Subject</u>	<u>WP Sequence No.-Page No.</u>
Assembly	
M8A3/M14 Orifice connector	
M113A3, M1059A3, and M577A3 only	
Replace.....	0780 00-1
Auxiliary power (slave) receptacle	
M113A3, M1059A3, M1064A3, and M58 only	
Replacement.....	0263 00-1 ■
Auxiliary power (slave) receptacle ground lead	
M113A3, M1059A3, M1064A3, and M58	
Replacement.....	0379 00-1 ■
Auxiliary Power Unit	
5.0 KW	
M577A3 and M1068A3	
Replacement.....	0675 00-1
Auxiliary Power Unit Fuel Shutoff Valve	
M577A3 and M1068A3	
Replacement.....	0676 00-1
Auxiliary Power Unit Valve-to-bulkhead Fuel Supply Hoses	
M577A3 and M1068A3	
Replacement.....	0677 00-1
Auxiliary Tank	
Replacement.....	0230 00-1
Auxiliary tank fluid level detector	
Replacement.....	0329 00-1
Azimuth lock	
Commander's cupola	
M113A3, M1059A3, M58, and M1064A3	
Replacement.....	0489 00-1
B	
Back Assembly	
Driver's Seat	
Repair.....	0554 00-1
Replacement.....	0553 00-1
Balance Hose	
Replacement.....	0234 00-1
Base	
Smoke grenade launcher	
M113A3 and M1059A3 only	
Replacement.....	0455 00-1 ■
Base Extension	
Right Side	
M1068A3	
Replacement.....	0623 00-1

INDEX, cont'd

<u>Subject</u>	<u>WP Sequence No.-Page No.</u>
Base Extension Supports	
Right Side	
M1068A3	
Replacement.....	0624 00-1
Batteries and battery box	
M58	
Replacement.....	0348 00-1
Batteries and retainers	
M113A3 and M1059A3	
Replacement.....	0346 00-1
M577A3 and M1068A3	
Replacement.....	0347 00-1
Battery	
Box	
M577A3 and M1068A3	
Repair.....	0351 00-1
M1064A3	
Replacement.....	0349 00-1
Retainers	
M1064A3	
Replacement.....	0349 00-1
Battery box	
M113A3 and M1059A3	
Repair.....	0350 00-1
Battery box (right side)	
M1064A3	
Repair.....	0354 00-1
Battery box access cover	
M577A3 and M1068A3	
Repair.....	0352 00-1
Battery box hose	
Engine to	
Replacement.....	0714 00-1
Battery Box Insulation and Heat Exchanger	
Replacement.....	0718 00-1
Battery box vent fitting	
M58	
Replacement.....	0355 00-1
Battery drawer	
M1064A3	
Repair.....	0353 00-1

INDEX, cont'd

<u>Subject</u>	<u>WP Sequence No.-Page No.</u>
Battery Drawer Insulation and Heat Exchanger	
M1064A3	
Replacement.....	0719 00-1
Battery ground lead	
M577A3 and M1068A3	
Connect	0338 00-1
Disconnect.....	0338 00-1
Battery ground strap	
M113A3, M1059A3, M1064A3, and M58	
Connect	0337 00-1
Disconnect.....	0337 00-1
Battery leads and terminals	
M113A3 and M1059A3	
Replacement.....	0340 00-1
M577A3 and M1068A3	
Replacement.....	0341 00-1
M58	
Replacement.....	0345 00-1
Battery leads and terminals (left side)	
M1064A3	
Replacement.....	0343 00-1
Battery leads and terminals (right side)	
M1064A3	
Replacement.....	0344 00-1
Battery Plate to Battery Plate Hose	
Replacement.....	0722 00-1
Battery to master switch lead (circuit 6)	
M1064A3	
Replacement.....	0358 00-1
M113A3 and M1059A 3	
Replacement.....	0356 00-1
M577A3 and M1068A3	
Replacement.....	0357 00-1
Battery-to-radio Wiring harness	
(Left Side)	
M113A3 and M1059A3	
Replacement.....	0369 00-1
Battery-to-radio wiring harness (right side)	
M113A3	
Replacement.....	0370 00-1
Battery/generator indicator malfunctions	0051 00-1

INDEX, cont'd

<u>Subject</u>	<u>WP Sequence No.-Page No.</u>
Bearing	
Tow Start Control Assembly	
Replacement.....	0391 00-1
Bearings	
Idler wheel arm	
Replacement.....	0418 00-1
Road wheel support	
Replacement.....	0415 00-1
Belt	
Generator drive	
Adjustment.....	0252 00-1
Replacement.....	0253 00-1
Ventilating Fan Drive	
Adjustment.....	0242 00-1
Replacement.....	0243 00-1
Belts	
Coolant Pump	
Adjustment.....	0239 00-1
Coolant Pump Idler	
Replacement.....	0240 00-1
Personnel	
M113A3	
Replacement.....	0546 00-1
M577A3	
Replacement.....	0547 00-1
Personnel seat	
M1059A3	
Replacement.....	0549 00-1
M1064A3	
Replacement.....	0550 00-1
Bilge Pump	
Front	
Replace.....	0632 00-1
Pipes	
Front, Replace.....	0631 00-1
Rear	
Replacement.....	0635 00-1
Bilge pump circuit breakers	
Replacement.....	0275 00-1
Bilge Pump Pipes	
Rear Bilge	
Replacement.....	0634 00-1

INDEX, cont'd

<u>Subject</u>	<u>WP Sequence No.-Page No.</u>
Blackout Curtain	
M577A3 and M1068A3	
Replacement.....	0629 00-1
Blackout dome lights do not work	
M1068A3 only	0041 00-1
Blackout drive light doesn't work.....	0030 00-1
Blackout headlight	
Repair	0306 00-1
Replacement.....	0305 00-1
Blackout marker light	
Repair	0308 00-1
Replacement.....	0307 00-1
Blackout marker light(s) don't work	0034 00-1
Blank display diagnostic troubleshooting	
STE/ICE	0138 00-1
Blower switch	
M577A3 and M1068A3 only	
Replacement.....	0278 00-1
Bottom access cover	
Power plant	
Replacement.....	0450 00-1
Box	
Battery	
M113A3 and M1059A3	
Repair.....	0350 00-1
Heater Control	
Coolant Heater	
Repair.....	0737 00-1
Repalcement.....	0736 00-1
Personnel Heater Control	
Repair	0702 00-1
Replacement.....	0701 00-1
Box Assembly A5	
Tent Interface Panel	
M1068A3	
Replacement.....	0833 00-1
Bracket	
Chemical Alarm Refill Tray	
M113A3	
Replacement.....	0922 00-1
Coolant Heater and Pump	
Replacement.....	0732 00-1

INDEX, cont'd

<u>Subject</u>	<u>WP Sequence No.-Page No.</u>
Generator	
Replacement.....	0255 00-1
M13 Orifice	
M1068A3 only	
Replace.....	0781 00-1
Oil Can	
Replacement.....	0574 00-1
Parking brake	
Replacement.....	0331 00-1
Power Extension Box A18	
M1068A3	
Replacement.....	0836 00-1
Ramp	
M113A3, M577A3, and M1068A3	
Replacement.....	0516 00-1
Ramp Door Stop	
Replacement.....	0517 00-1
Roadside Data Panel Assembly A13	
M1068A3	
Replacement.....	0835 00-1
Spare Battery, Chemical Alarm	
M113A3	
Replace/Repair.....	0921 00-1
Transmission range controller	
Used with cable-activated steering lock	
Replacement.....	0387 00-1
Used with solenoid-activated steering lock	
Replacement.....	0386 00-1
Bracket,	
Mortar Base Stowage	
M1064A3	
Replacement.....	0615 00-1
Windshield Stowage	
M1064A3	
Replacement.....	0614 00-1
Brackets	
Rifle	
Replacement.....	0573 00-1
Brackets and Mounts	
Right Equipment Rack	
M1068A3	
Replacement.....	0814 00-1

INDEX, cont'd

<u>Subject</u>	<u>WP Sequence No.-Page No.</u>
Brake	
Parking	
Adjustment.....	0408 00-1
Brake adjustment	
Transmission	
Check	0406 00-1
Brake assembly	
Commander's cupola	
M113A3, M1059A3, M58, and M1064A3	
Replacement.....	0492 00-1
Brakes	
Transmission	
Adjust.....	0394 00-1
Breather Hose	
Ramp Cylinder	
All Except M1064A3	
Replacement.....	0666 00-1
M1064A3	
Replacement.....	0667 00-1
Bulkhead Connection Hose	
Fuel Pump to	
M113A3, M1059A3, and M58	
Replacement.....	0691 00-1
Bulkhead connection to Personnel Heater Tube	
M577A3 and M1068A3	
Replacement.....	0687 00-1
Bumper	
Driver's Hatch	
M113A3, M1059A3, M1064A3, and M58	
Replacement.....	0532 00-1
Buzzer and switch	
Admittance	
M577A3 and M1068A3	
Replacement.....	0334 00-1
Bypass plug	
Differential	
Replacement.....	0401 00-1
C	
Cable	
Adapter	
M1068A3	
Replacement.....	0849 00-1, 0850 00-1

INDEX, cont'd

<u>Subject</u>	<u>WP Sequence No.-Page No.</u>
Artillery Communication Inside	
M577A3	
Replacement.....	0746 00-1
Commander's Intercommunication Set	
M58	
Replacement.....	0893 00-1
Driver's Intercommunication Set	
M58	
Replacement.....	0892 00-1
Instrument panel special purpose	
Replacement.....	0290 00-1
Operator's Intercommunication Set	
M58	
Replacement.....	0894 00-1
Reel holder	
M1064A3	
Replacement.....	0603 00-1
Speedometer	
Repair.....	0861 00-1
Replace.....	0860 00-1
Service.....	0858 00-1
Tachometer	
Repair.....	0865 00-1
Replace.....	0864 00-1
Service.....	0858 00-1
W251	
M1068A3	
Replacement.....	0852 00-1
W252	
M1068A3	
Replacement.....	0857 00-1
W28	
M1068A3	
Replacement.....	0849 00-1
W29	
M1068A3	
Replacement.....	0850 00-1
W35	
M1068A3	
Replacement.....	0849 00-1
W38	
M1068A3	
Replacement.....	0850 00-1

INDEX, cont'd

<u>Subject</u>	<u>WP Sequence No.-Page No.</u>
W42	
M1068A3	
Replacement.....	0852 00-1
W43	
M1068A3	
Replacement.....	0852 00-1
Cable (W10)	
DC Power Extension	
M1068A3	
Replace.....	0844 00-1
Cable (W11)	
AC Light	
M1068A3	
Replacement.....	0845 00-1
Cable (W4)	
DC Battery	
M1068A3	
Replacement.....	0838 00-1
Cable (W40)	
Single Point LAN	
M1068A3	
Replacement.....	0851 00-1
Cable (W5)	
Inverter AC	
Replacement/Repair	0839 00-1
Cable (W6)	
Inverter DC	
M1068A3	
Replacement.....	0840 00-1
Cable (W7)	
AC Power Extension	
M1068A3	
Replacement.....	0842 00-1
Cable (W8)	
AC Power Extension (M1068A3)	
Replace.....	0843 00-1
Cable Assembly	
Control	
Tow Start	
Adjustment.....	0390 00-1
Smoke Generator Internal	
M1059A3	
Replacement.....	0760 00-1

INDEX, cont'd

<u>Subject</u>	<u>WP Sequence No.-Page No.</u>
Cable assembly	
Driver's night vision (DNV) (AN/VVS-2) power supply	
All Except M58	
Replacement.....	0368 00-1
Cable Assembly (W4/W6)	
M1068A3	
Repair	0841 00-1
Cable reel holder assembly	
M1064A3	
Repair	0604 00-1
Cable Tube	
External	
Replacement.....	0905 00-1
Cable W3	
Power Distribution	
M1068A3	
Replacement.....	0837 00-1
Cable-activated steering lock malfunctions.....	0077 00-1
Cables	
LAN A or B (W103/W104)	
M1068A3	
Replacement.....	0854 00-1
W124	
M1068A3	
Replacement.....	0855 00-1
W126	
M1068A3	
Replacement.....	0856 00-1
W45	
M1068A3	
Replacement.....	0853 00-1
Cables and switch assembly	
M14 NBC	
M1059A3	
Replacement.....	0799 00-1
Cap	
Muffler	
Replacement.....	0223 00-1
Cargo hatch cover	
M113A3 and M1059A3	
Replacement.....	0479 00-1

INDEX, cont'd

<u>Subject</u>	<u>WP Sequence No.-Page No.</u>
Cargo hatch hold-open hook and bumpers	
M113A3 and M1059A3	
Replacement.....	0474 00-1
Cargo hatch interior latch	
M113A3 and M1059A3	
Replacement.....	0475 00-1
Cargo hatch seals	
M113A3 and M1059A3	
Replacement.....	0478 00-1
Wheel assembly	
Drive sprocket	
Repair.....	0421 00-1
Carrier does not move in any shift lever position.....	0062 00-1
Carrier drifts or does not steer.....	0063 00-1
Carrier moves with transmission in SL.....	0061 00-1
Cascade Remote Harness	
M1068A3	
Replacement.....	0847 00-1
Catches and bumpers	
Mortar hatch exterior	
M1064A3	
Replacement.....	0480 00-1
Chain Assembly, Litter Kit	
M113A3	
Repair.....	0745 00-1
Chain Assembly, Litter Kit	
M113A3	
Replace.....	0744 00-1
Chemical Agent Automatic Alarm Kit	
Junction Box	
M113A3	
Repair.....	0920 00-1
M113A3	
Installation/Removal.....	0918 00-1
Junction Box	
Replacement.....	0919 00-1
Refill Tray Bracket	
M113A3	
Replacement.....	0922 00-1
Spare Battery	
M113A3	
Replace/Repair.....	0921 00-1

INDEX, cont'd

<u>Subject</u>	<u>WP Sequence No.-Page No.</u>
Wiring Harnesses, M43 Unit Interface	
M113A3	
Replacement.....	0923 00-1
Circuit breaker	
Dome light	
M577A3 and M1068A3	
Replacement.....	0316 00-1
Replacement.....	0280 00-1
Circuit breakers	
Bilge pump	
Replacement.....	0275 00-1
Rear utility receptacle	
M577A3 and M1068A3 only	
Replacement.....	0276 00-1
Clamps	
Tent	
M577A3	
Replacement.....	0627 00-1
Coil	
Air Box Ignition	
Replacement.....	0208 00-1
Combat filler cover and lock	
Replacement.....	0466 00-1
Combat lock	
Power plant door	
Replacement.....	0473 00-1
Commander's Cupola	
Armor Shields	
M113A3, M1059A3, and M1064A3	
Replacement.....	0747 00-1
Commander's cupola azimuth lock	
M113A3, M1059A3, M58, and M1064A3	
Replacement.....	0489 00-1
Commander's cupola brake assembly	
M113A3, M1059A3, M58, and M1064A3	
Replacement.....	0492 00-1
Commander's cupola cover	
M113A3, M1059A3, and M1064A3	
Replacement.....	0493 00-1
Commander's cupola cushioning pad and handle	
M113A3, M1059A3, M58, and M1064A3	
Replacement.....	0488 00-1

INDEX, cont'd

<u>Subject</u>	<u>WP Sequence No.-Page No.</u>
Commander's cupola hold-open hook and bumper M113A3, M1059A3, M58, and M1064A3 Replacement.....	0494 00-1
Commander's cupola interior latch M113A3, M1059A3, M58, and M1064A3 Replacement.....	0496 00-1
Commander's cupola machine gun mount M113A3, M1059A3, M58, and M1064A3 Repair.....	0498 00-1
	Replacement..... 0497 00-1
Commander's cupola machine gun mount stops M1059A3 Replacement.....	0499 00-1
Commander's cupola safety pin stowage block M113A3, M1059A3, M58, and M1064A3 Replacement.....	0495 00-1
Commander's cupola vision block locks and seals M1064A3 Replacement.....	0491 00-1
	M113A3 and M1059A3, M58 Replacement..... 0490 00-1
Commander's Display Mounting Bracket (DVE) M58 Replacement.....	0866 06-1
Commander's hatch cover M577A3 and M1068A3 Replacement.....	0503 00-1
Commander's hatch cushioning pad and handle M577A3 and M1068A3 Replacement.....	0500 00-1
Commander's hatch hook and bumper M577A3 and M1068A3 Replacement.....	0501 00-1
Commander's hatch interior latch M577A3 and M1068A3 Replacement.....	0502 00-1
Commander's Intercommunication Set Cable M58 Replacement.....	0893 00-1
Commander's Jump Seat M113A3 Replacement.....	0563 00-1

INDEX, cont'd

<u>Subject</u>	<u>WP Sequence No.-Page No.</u>
Commander's platform	
M113A3, M1059A3, M1064A3, and M58	
Replacement/repair.....	0559 00-1
Commander's Platform and Post	
M577A3 and M1068A3	
Replacement/Repair	0564 00-1
Commander's Seat	
M1068A3	
Replacement/repair.....	0566 00-1
Commander's seat	
M113A3, M1059A3, M1064A3, and M58	
Repair	0562 00-1
Commander's Seat and Post	
M1064A3	
Replacement.....	0561 00-1
M113A3, M1059A3, and M58	
Replacement.....	0560 00-1
Commander's Vision Enhancer (DVE) display does not work.....	0116 02-1
Communication Box A11, External	
Lid and Latches	
Replace (M1068A3).....	0818 00-1
Communication Box A11, External (M1068A3)	
Replace	0817 00-1
Communication Cabling Diagram	
M58	0884 00-1
Confidence test diagnostic troubleshooting	
STE/ICE	0139 00-1
Connector assembly	
M13 Orifice	
M1068A3 only	
Replace.....	0781 00-1
Connector assembly, bracket, and quick coupling half	
M13 Orifice	
M1068A3 only	
Replace.....	0781 00-1
Control Assembly and Bearing	
Tow Start	
Replacement.....	0391 00-1
Control assembly, bracket, links, and pins (cable-activated lock)	
Push-pull	
Replacement.....	0429 00-1

INDEX, cont'd

<u>Subject</u>	<u>WP Sequence No.-Page No.</u>
Control Box	
Coolant Heater	
Repair	0737 00-1
Replacement	0736 00-1
Personnel Heater	
Repair	0702 00-1
Replacement	0701 00-1
Control Cable Assembly	
Fuel Cutoff	
Replacement	0220 00-1
Hand throttle	
Replacement	0219 00-1
Control cable assembly	
Parking brake	
Replacement	0411 00-1
Control lever assembly	
Parking brake	
Replacement	0412 00-1
Control linkage	
Service brake	
Adjustment	0407 00-1
Replacement	0410 00-1
Trim vane	
Repair	0461 00-1
Control Valve	
Fire Extinguisher	
Replacement	0904 00-1
Control Valve (with Internal Relief Valve)	
Ramp	
Replacement	0661 00-1
Controller	
Glow plug	
Replacement	0210 00-1
Controller Mounting Bracket	
Glow Plug	
Replacement	0212 00-1
Coolant Air Separator	
Replacement	0236 00-1
Coolant Heater	
Control Box	
Repair	0737 00-1
Replacement	0736 00-1

INDEX, cont'd

<u>Subject</u>	<u>WP Sequence No.-Page No.</u>
Coolant	
Heater to Engine Elbow, Replace	0715 00-1
Exhaust Elbow and Pipes	
Replacement	0724 00-1
Fuel Pump	
Replacement	0723 00-1
Fuel Shutoff Valve	
Replacement	0720 00-1
Hoes	
Fuel	
Inlet, Replace	0712 00-1
Hoses	
Coolant	
Pump to Battery Box, Replace	0713 00-1
Fuel	
Filter Valve, Replace	0716 00-1
Pump, Replace	0711 00-1
Pump	
Replacement	0731 00-1
Replace	0728 00-1, 0729 00-1
Wiring Harness	
Replacement	0735 00-1
Coolant Heater and Pump	
Bracket	
Replacement	0732 00-1
Coolant Heater Fuel Filter	
Service	0708 00-1
Coolant Heater Fuel Pump	
Service	0709 00-1
Coolant heater malfunctions	0089 00-1
Coolant Heater to Surge Tank Hose	
Replacement	0725 00-1
Coolant Hose and Tube	
Upper	
Replacement	0232 00-1
Coolant Pump Belts	
Adjustment	0239 00-1
Coolant temp indicator malfunctions	0053 00-1
Coolant temperature transmitter	
Replacement	0321 00-1
Cooling system	
Drain and fill	0227 00-1

INDEX, cont'd

<u>Subject</u>	<u>WP Sequence No.-Page No.</u>
Cover	
Antenna	
Replacement.....	0576 00-1
Battery box access	
M577A3 and M1068A3	
Repair.....	0352 00-1
Cargo hatch	
M113A3 and M1059A3	
Replacement.....	0479 00-1
Commander's cupola	
M113A3, M1059A3, and M1064A3	
Replacement.....	0493 00-1
Commander's hatch	
M577A3 and M1068A3	
Replacement.....	0503 00-1
Driver's Hatch	
Replacement.....	0531 00-1
Fan drive pulley access	
Removal/installation.....	0440 00-1
Thermostat	
Replacement.....	0237 00-1
Tow Start Control Assembly	
Replacement.....	0392 00-1
Covers	
Mortar hatch	
Cushioning Pad	
Driver's Hatch	
Replacement.....	0530 00-1
Cushioning pad and handle	
Commander's cupola	
M113A3, M1059A3, M58, and M1064A3	
Replacement.....	0488 00-1
Commander's hatch	
M577A3 and M1068A3	
Replacement.....	0500 00-1
Cushions	
Personnel	
M113A3	
Replacement.....	0546 00-1
M577A3	
Replacement.....	0547 00-1

INDEX, cont'd

<u>Subject</u>	<u>WP Sequence No.-Page No.</u>
Personnel Seat	
M1059A3	
Replacement.....	0549 00-1
M1064A3	
Replacement.....	0550 00-1
Cylinder	
Fire Extinguisher	
Discharge Tubes	
Replacement.....	0899 00-1
Ramp	
Replacement.....	0656 00-1
Cylinder, Turbine	
Fire Extinguisher Discharge Tubes	
M58	
Replacement.....	0900 00-1
D	
Data Panel Assembly	
A13 Roadside	
M1068A3	
Replacement.....	0835 00-1
Data Panel Assembly (M1068A3)	
A12, Curbside	
Replace.....	0819 00-1
Data Plates, Stencils, Markers, and Decals	
Replacement.....	0654 00-1
Dataplates, Decals, and Markers	
All Models.....	0644 00-1
M1059A3	0651 00-1
M1064A3	0652 00-1
M113A3, M1059A3	0647 00-1
M113A3, M1059A3, M58	0646 00-1
M113A3, M1059A3	0645 00-1
M577A3, M1068A3 Only	0648 00-1
M58	0653 00-1
DC Battery Cable (W4)	
M1068A3	
Replacement.....	0838 00-1
DC Power Extension Box A9	
M1068A3	
Replacement.....	0834 00-1
DC Power Extension Cable (W10)	
M1068A3	
Replacement.....	0844 00-1

INDEX, cont'd

<u>Subject</u>	<u>WP Sequence No.-Page No.</u>
DCA battery voltage diagnostic troubleshooting	0141 00-1
DCA current shunt diagnostic troubleshooting	0142 00-1
Detector	
Auxiliary tank fluid level	
Replacement	0329 00-1
Diagram	
Communication Cabling	
M58	0884 00-1
Differential Pressure Switch	
Fuel Filter	
Replacement	0328 00-1
Differential pressure switch	
Replacement	0401 00-1
Dipstick	
Transmission oil level filler tube, and adapter	
X200-4	
Replacement	0395 00-1
X200-4A	
Replacement	0396 00-1
Discharge Tubes	
Cylinder	
Replacement	0899 00-1
Cylinder, Turbine	
M58	
Replacement	0900 00-1
STE/ICE	
M1064A3	
Replacement	0877 00-1
M113A3 and M1059A3	
Replacement	0874 00-1
M577A3 and M1068A3	
Replacement	0875 00-1
Distribution box	
M113A3, M1059A3, M1064A3, and M58	
Replacement	0269 00-1
M113A3, M1059A3, M1064A3, and M58 only	
Repair	0270 00-1
M577A3 and M1068A3 only	
Replacement	0271 00-1
Dome blackout light bypass switch	
M577A3 and M1068A3	
Replacement	0317 00-1

INDEX, cont'd

<u>Subject</u>	<u>WP Sequence No.-Page No.</u>
Dome light	
All Except M577A3 and M1068A3	
Repair	0310 00-1
Replacement	0309 00-1
M577A3 and M1068A3	
Repair	0312 00-1
Replacement	0311 00-1
Dome light and mount	
M577A3 and M1068A3	
Repair	0312 00-1
Dome light circuit breaker	
M577A3 and M1068A3	
Replacement	0316 00-1
Dome light lens	
All Except M577A3 and M1068A3	
Replacement	0313 00-1
Dome light malfunction	
M577A3 only	0040 00-1
Dome light switch	
Front	
M577A3 and M1068A3	
Replacement	0314 00-1
Rear	
M577A3 and M1068A3	
Replacement	0315 00-1
Dome light(s) do not work	0039 00-1
Door	
Power plant	
All except M113A3	
Replacement	0471 00-1
M113A3	
Replacement	0470 00-1
Repair	0472 00-1
Door combat lock	
Power plant	
Replacement	0473 00-1
Drain Check Valve and tubes	
Left Air Box	
Replace	0159 00-1
Drain Cock and Hose	
Replacement	0235 00-1

INDEX, cont'd

<u>Subject</u>	<u>WP Sequence No.-Page No.</u>
Drain plug	
Hull	
Replacement.....	0451 00-1
Drain plugs	
Final drive hull	
Replacement.....	0452 00-1
Fuel tank	
All except M577A3 and M1068A3	
Replacement.....	0187 00-1
Ramp	
Replacement.....	0515 00-1
Drawer	
Battery	
M1064A3	
Repair.....	0353 00-1
Drive Belt	
Ventilating Fan	
Adjustment.....	0242 00-1
Replacement.....	0243 00-1
Drive belt	
Generator	
Replacement.....	0253 00-1
Drive Pulley	
Ventilating Fan	
Replacement.....	0244 00-1
Drive shaft and bearing housing	
Fan	
Replacement.....	0248 00-1
Drive sprocket and wheel assembly	
Replacement.....	0420 00-1
Drive sprocket wheel assembly	
Drive sprocket	
Repair.....	0420 01-1, 0421 00-1
Driver's compartment floor plates	
Replacement.....	0453 00-1
Driver's Display Mounting Bracket (DVE)	
M58	
Replacement.....	0866 02-1
Driver's footrest	
Replacement.....	0558 00-1

INDEX, cont'd

<u>Subject</u>	<u>WP Sequence No.-Page No.</u>
Driver's Hatch	
Bumper	
M113A3, M1059A3, M1064A3, and M58	
Replacement.....	0532 00-1
Cushioning Pad	
Replacement.....	0530 00-1
Exterior Lock	
Replacement.....	0531 00-1
Hold-open Hook	
M113A3, M1059A3, M1064A3, and M58	
Replacement.....	0532 00-1
Driver's hatch night vision mount	
M58	
Replacement.....	0537 01-1
Driver's Intercommunication Set	
Cable	
M58	
Replacement.....	0892 00-1
Driver's night vision (DNV) (AN/VVS-2) power supply cable assembly	
All Except M58	
Replacement.....	0368 00-1
Driver's night vision guard (AN/VVS-2)	
Driver's Hatch	
All Except M58	
Replacement.....	0536 00-1
Driver's night vision mount	
AN/VVS-2	
All Except M58	
Replacement.....	0537 00-1
Driver's night vision mount (AN/VVS-2)	
All Except M58	
Replacement.....	0537 00-1
Driver's Night Vision Stowage	
AN/VVS-2	
All Except M58	
Replacement.....	0572 00-1
Driver's power plant access panel	
Replacement.....	0441 00-1
Driver's Seat	
Repair.....	0552 00-1
Driver's seat assembly	
Replacement.....	0551 00-1

INDEX, cont'd

<u>Subject</u>	<u>WP Sequence No.-Page No.</u>
Driver's seat back assembly	
Repair	0554 00-1
Replacement	0553 00-1
Driver's seat impact absorber	
Replacement	0555 00-1
Driver's seat post assembly	
Repair	0557 00-1
Replacement	0556 00-1
Driver's Vision Enhancer (DVE) AN/VAS-5 Power Supply Cable M58	
Replacement	0866 04-1
Driver's Vision Enhancer (DVE) display does not work	0116 01-1
Driver's windshield	
Replacement	0739 00-1
towage bag, straps, and decal	
Replacement	0740 00-1
DVE Sensor Set Assembly Power Cable M58	
Replacement	0866 01-1
E	
Elbow	
Air intake	
Replace	0173 00-1
Coolant Heater Exhaust	
Replacement	0724 00-1
Electrical Cable Assembly	
Air Compressor	
M1059A3	
Replacement	0758 00-1
Fog Oil Pump	
M1059A3	
Replacement	0759 00-1
Element	
Filter	
Air Cleaner	
Service	0167 00-1
Enclosure	
Generator set	
M577A3 and M1068A3	
Replacement	0674 00-1

INDEX, cont'd

<u>Subject</u>	<u>WP Sequence No.-Page No.</u>
Enclosure Assembly A1	
Power Control	
M1068A3	
Replacement.....	0826 00-1
Engine	
Adapter, Tachometer	
Replace.....	0863 00-1
Block Fitting and Hardware	
Replacement.....	0717 00-1
Exhaust elbows	
Left/right, replace.....	0225 00-1
Fuel return hose	
Replacement.....	0201 00-1
Fuel supply hose	
Replacement.....	0200 00-1
Lifting bracket, replace.....	0161 00-1
Oil filler cap, replace.....	0162 00-1
Oil sampling valve and hose, replace.....	0163 00-1
Engine Coolant Heater System	
Drain and Fill.....	0710 00-1
Engine coolant low level indicator malfunctions.....	0058 00-1
Engine Coolant Pump	
Replacement.....	0241 00-1
Engine cranks but will not start.....	0021 00-1
Engine cranks but won't start below 40 degrees (air box heater is used).....	0022 00-1
Engine cranks but won't start below 40 degrees F (glow plugs are used).....	0023 00-1
Engine cranks slowly.....	0020 00-1
Engine does not crank.....	0016 00-1
Engine does not start (cold weather only).....	0017 00-1
Engine exhaust elbows and double flex joint	
Replacement.....	0221 00-1
Engine fuel pump	
Replacement.....	0166 00-1
Engine Mounts	
Replace.....	0158 00-1
Engine oil low pressure indicator comes on.....	0026 00-1
Engine oil low pressure indicator malfunctions.....	0055 00-1
Engine oil low pressure transmitter and hardware	
Replacement.....	0320 00-1
Engine overcools.....	0015 00-1
Engine overheats (Old VSFD Configuration).....	0014 00-1
Engine overheats (New VSFD Configuration).....	0014 01-1
Engine runs rough, stalls, or doesn't put out full power.....	0024 00-1

INDEX, cont'd

<u>Subject</u>	<u>WP Sequence No.-Page No.</u>
Engine start switch	
Replacement	0284 00-1
Engine to battery box hose	
Replacement	0714 00-1
Engine wiring harness	
Replacement	0359 00-1
Equipment Description	0002 00-1
Location and Description of Major Components	0002 00-1
Evacuator valve and connector	
Exhaust	
Replace	0175 00-1
Exhaust	
Evacuator valve and connector	
Replace	0175 00-1
Exhaust elbows and double flex joint	
Engine	
Replacement	0221 00-1
Exhaust Joint, Double Flex, Repair	0222 00-1
Exhaust muffler and bracket	
Replace	0224 00-1
Exhaust Pipe Heat Shield, Turbo, Left/Right, Replace	0226 00-1
Exhaust Pipes, Heater	
All Except M1064A3	
Replacement	0682 00-1
Expendable/Durable Supplies and Materials List	0928 00-1
Extender Assembly	
Tow Pintle	
M113A3	
Repair	0811 02-1
Extender Kit	
Tow Pintle	
M113A3	
Installation	0811 01-1
Extension	
Muffler	
Replacement	0223 00-1
Engine overheats (New VSFD Configuration)	0014 01-1
Extension Box A7	
AC Power	
Replace	0815 00-1

INDEX, cont'd

<u>Subject</u>	<u>WP Sequence No.-Page No.</u>
Exterior catches and bumpers	
Mortar hatch	
M1064A3	
Replacement.....	0480 00-1
Exterior Lock	
Driver's Hatch	
Replacement.....	0531 00-1
External Cable Tube	
Replacement.....	0905 00-1
External Handle	
Fire Extinguisher	
Replacement.....	0904 00-1
External Handle Shield	
M1064A3	
Replacement.....	0903 00-1
M113A3 and M1059A3	
Replacement.....	0901 00-1
M577A3 and M1068A3	
Replacement.....	0902 00-1
Extinguisher, Fire	
Cylinder and Mount	
Replacement.....	0898 00-1
F	
Fan	
Variable Speed Drive	0249 00-1
Fan	
Variable Speed Drive	
Fan Drive Assembly.....	0249 01-1
Fan	
Variable Speed Drive	
Controller	0250 01-1
Fan	
Ventilation	
M577A3 and M1068A3	
Replacement.....	0383 00-1
Fan and generator variable speed drive	
Replacement.....	0249 00-1
Fan drive pulley access cover	
Removal/installation	0440 00-1
Fan drive shaft and bearing housing	
Replacement.....	0248 00-1

INDEX, cont'd

<u>Subject</u>	<u>WP Sequence No.-Page No.</u>
Field pressure switch	
Generator	
Replacement.....	0323 00-1
Filler Cap	
Strainer Parts	
All Except M577A3 and M1068A3	
Replacement.....	0184 00-1
M577A3 and M1068A3	
Replacement.....	0185 00-1
Filler Cover and Lock	
Fuel Tank	
All Except M577A3 and M1068A3	
Replacement.....	0182 00-1
Filler Flange	
Fuel Tank	
M577A3 and M1068A3	
Replacement.....	0189 00-1
Filler tube	
Dipstick, transmission oil level	
X200-4	
Replacement.....	0395 00-1
X200-4A	
Replacement.....	0396 00-1
Filler tube and dipstick	
Final drive	
Replacement.....	0402 00-1
Filler, fuel and strainer parts	
M577A3 and M1068A3	
Replacement.....	0186 00-1
Filter	
Fuel	
Replacement.....	0726 00-1
Filter Element	
Transmission oil	
Replacement.....	0398 00-1
Filter Fuel Supply Hoses	
M113A3, M1059A3, and M58	
Replacement.....	0685 00-1
Final drive	
Replacement.....	0403 00-1
Final drive differential oil seal	
Replacement.....	0404 00-1

INDEX, cont'd

<u>Subject</u>	<u>WP Sequence No.-Page No.</u>
Final drive filler tube and dipstick	
Replacement	0402 00-1
Final drive hull drain plugs	
Replacement	0452 00-1
Fire Extinguisher	
Cylinder and Mount	
Replacement	0898 00-1
Fire Extinguisher	
Control Valve	
Replacement	0904 00-1
External Handle	
Replacement	0904 00-1
M1059A3	
Replacement	0896 00-1
Fittings	
Coolant Heater Fuel Inlet	
Replace	0712 00-1
Fuel Return	
M1064A3	
Replacement	0197 00-1
M113A3, M1059A3, and M58	
Replacement	0195 00-1
M577A3 and M1068A3	
Replacement	0196 00-1
Fuel Vent	
M577A3 and M1068A3	
Replacement	0198 00-1
Personnel heater	
M577A3 and M1068A3	
Replacement	0700 00-1
Ramp Control Valve (with Internal Relief Valve)	
Replacement	0661 00-1
Flame Detector Switch	
Adjust	0727 00-1
Coolant Heater	
Replacement	0734 00-1
Flat pulleys and bearings	
Replacement	0245 00-1
Floor Plates	
M1059A3	
Replacement	0542 00-1
M1064A3	
Replacement	0543 00-1

INDEX, cont'd

<u>Subject</u>	<u>WP Sequence No.-Page No.</u>
M1068A3	
Replacement.....	0544 00-1
M113A3 and M577A3	
Replacement.....	0539 00-1
M58	
Replacement.....	0545 00-1
Floor plates	
Driver's compartment	
Replacement.....	0453 00-1
Fluid level detector	
Auxiliary tank	
Replacement.....	0329 00-1
Fluorescent Light Assemblies	
M1068A3	
Replacement.....	0825 00-1
Fluorescent lights do not operate	
M1068A3 only	0102 00-1
Fog Oil Pump	
Electrical Cable Assembly	
M1059A3	
Replacement.....	0759 00-1
Fog Oil Pump Assembly	
(M1059A3 Only)	
Replace.....	0763 00-1
Fog Oil Quick Disconnect to Adapter Access Plate Hose (M1059A3), Cover Assembly	
Replace.....	0770 00-1
Fog Oil Tank (M1059A3)	
Hose	
Quick Disconnect to Adapter Access Plate	
Replace.....	0769 00-1
Fog Oil Tank Module	
M1059A3	
Replacement.....	0753 00-1
Footrest	
Driver's	
Replacement.....	0558 00-1
Forward spall liner and bracket	
M113A3	
Replacement.....	0507 00-1
Forward Table, Right	
M577A3	
Replacement.....	0581 00-1

INDEX, cont'd

<u>Subject</u>	<u>WP Sequence No.-Page No.</u>
Forward upper right and left side spill liners	
M113A3	
Replacement.....	0508 00-1
Frame	
Blackout Curtain	
M577A3 and M1068A3	
Replacement.....	0629 00-1
Front access cover	
Hull	
Replacement.....	0449 00-1
Front and/or rear bilge pump(s) and/or lights don't work.....	0080 00-1
Front Armor	
M113A3	
Replacement.....	0749 00-1
Front armor plate	
Left	
Replacement.....	0447 00-1
Right	
Replacement.....	0448 00-1
Front Bilge Pump	
Replace.....	0632 00-1
Strainer	
Replace.....	0632 00-1
Front Bilge Valve	
Replace.....	0633 00-1
Front dome light switch	
M577A3 and M1068A3	
Replacement.....	0314 00-1
Fuel Shutoff Valve	
Coolant Heater	
Replacement.....	0720 00-1
Fuel Can Lid Assembly	
Smoke Generator (M1059A3)	
Replace.....	0764 00-1
Fuel cap vent and filter screen, clean.....	0176 00-1
Fuel Control Linkage	
Replacement.....	0217 00-1
Fuel Control Shaft	
Replacement.....	0217 00-1
Fuel Cutoff Control Cable Assembly	
Replacement.....	0220 00-1
Fuel Filters and Brackets	
Primary and Secondary.....	0203 00-1

INDEX, cont'd

<u>Subject</u>	<u>WP Sequence No.-Page No.</u>
Fuel Filter	
Coolant Heater	
Service.....	0708 00-1
Replacement.....	0726 00-1
Fuel filter	
Personnel heater	
M577A3 and M1068A3	
Replacement.....	0700 00-1
Fuel Filter Differential Pressure Switch	
Replacement.....	0328 00-1
Fuel Filter Elements	
Primary and Secondary	
Replacement.....	0202 00-1
Fuel filter, hose, tube, and fittings	
Personnel heater	
M577A3 and M1068A3	
Replacement.....	0700 00-1
Fuel filter, hoses, and fittings	
Personnel heater	
M1064A3	
Replacement.....	0688 00-1
Fuel Filters and Brackets	
Primary and Secondary	
Replacement.....	0203 00-1
Fuel level indicator malfunctions .	0049 00-1
Fuel Line	
Lower	
Air Box Heater	
Replacement.....	0206 00-1
Fuel Lines	
Air From Personnel Heater	
Bleed	0679 00-1
Fuel Lines and Guards	
Smoke Generator (M1059A3)	
Replace.....	0765 00-1
Fuel Pump	
Coolant Heater	
Replacement.....	0723 00-1
Service.....	0709 00-1
Personnel Heater	
M113A3, M1059A3, and M58	
Replacement.....	0695 00-1

INDEX, cont'd

<u>Subject</u>	<u>WP Sequence No.-Page No.</u>
Fuel pump	
Engine	
Replacement.....	0166 00-1
Fuel Pump Hose	
Coolant Heater	
Replace.....	0711 00-1
Fuel quantity transmitter	
All except M577A3 and M1068A3	
Replacement.....	0190 00-1
M577A3 and M1068A3	
Replacement.....	0191 00-1
Fuel return hoses	
Engine	
Replacement.....	0201 00-1
M1064A3	
Replacement.....	0197 00-1
M 113A3, M1059A3, and M58	
Replacement.....	0195 00-1
M577A3 and M1068A3	
Replacement.....	0196 00-1
Fuel return pressure transducer	
Replacement.....	0325 00-1
Fuel select switch to gauge lead	
All Except M577A3 and M1068A3	
Replacement.....	0281 00-1
Fuel selector switch	
M577A3 and M1068A3 only	
Replacement.....	0277 00-1
Fuel Shut-off Valve assembly	
M113A3, M1059A3, and M58	
Replacement.....	0684 00-1
Fuel Shutoff Valve	
Auxiliary Power Unit	
M577A3 and M1068A3	
Replacement.....	0676 00-1
Fuel Supply	
Hoses, Tubes, and Fittings	
M1064A3	
Replacement.....	0194 00-1
M113A3, M1059A3, and M58	
Replacement.....	0192 00-1

INDEX, cont'd

<u>Subject</u>	<u>WP Sequence No.-Page No.</u>
Fuel supply	
Hoses, tubes, and fittings	
M577A3 and M1068A3	
Replacement.....	0193 00-1
Fuel Supply Hoses	
Auxiliary Power Unit Valve-to-bulkhead	
M577A3 and M1068A3	
Replacement.....	0677 00-1
Fuel supply hoses	
Auxiliary power unit bulkhead-to-hull	
M577A3 and M1068A3	
Replacement.....	0678 00-1
Engine	
Replacement.....	0200 00-1
Fuel supply pressure transducer	
Replacement.....	0324 00-1
Fuel Tank	
Filler Cover and Lock	
All Except M577A3 and M1068A3	
Replacement.....	0182 00-1
Filler Flange	
M577A3 and M1068A3	
Replacement.....	0189 00-1
Fuel tank access covers	
M577A3 and M1068A3	
Replacement.....	0188 00-1
Fuel tank drain plugs	
M577A3 and M1068A3	
Replacement.....	0187 00-1
Fuel tank filler	
Cover and lock	
M577A3 and M1068A3	
Replacement.....	0183 00-1
Fuel Tank to Fuel Pump Hose	
M577A3 and M1068A3	
Replacement.....	0690 00-1
Fuel Tanks	
Drain	
M577A3 and M1068A3	0178 00-1

INDEX, cont'd

<u>Subject</u>	<u>WP Sequence No.-Page No.</u>
Fuel tanks	
All except M577A3 and M1068A3, replace	0179 00-1
Drain	
All except M577A3 and M1068A3.....	0177 00-1
M577A3 and M1068A3	
Replacement.....	0180 00-1
Temporary repair (M577A3 and M1068A3).....	0181 00-1
Fuel Tube	
Personnel Heater	
All Except M1064A3	
Replacement.....	0686 00-1
Fuel Valve	
Mounting Blocks	
All Except M577A3 and M1068A3	
Replacement.....	0199 00-1
Fuel Vent Hoses, Tubes, and Fittings	
M577A3 and M1068A3	
Replacement.....	0198 00-1
G	
Gasket	
Adapter Access Plate	
Smoke Generator (M1059A3)	
Replace.....	0766 00-1
Turbine access door	
M58	
Replacement.....	0486 00-1
Gauges	
Instrument panel	
Replacement.....	0285 00-1
General Information	0001 00-1
Generator	
Drive belt	
Replacement.....	0253 00-1
Replacement.....	0255 00-1
Turnbuckle parts	
Replacement.....	0254 00-1
Generator	
Variable Speed Drive	0249 00-1
Generator drive belt	
Adjustment	0252 00-1
Generator field pressure switch	
Replacement.....	0323 00-1
Generator malfunctions as indicated by battery/generator indicator.....	0025 00-1

INDEX, cont'd

<u>Subject</u>	<u>WP Sequence No.-Page No.</u>
Generator set	
Enclosure	
M577A3 and M1068A3	
Replacement.....	0674 00-1
Glow Plug	
Controller Mounting Bracket	
Replacement.....	0212 00-1
Glow Plug Cable Assembly	
Smoke Generator (M1059A3)	
Replace.....	0772 00-1
Glow plug controller	
Replacement.....	0210 00-1
Glow plug harness	
Replacement.....	0209 00-1
Glow Plug Power Harness	
Replacement.....	0211 00-1
Glow plugs	
Replacement.....	0209 00-1
Governor assembly	
Replacement.....	0397 00-1
Grenade Stowage box	
M1064A3	
Replacement.....	0610 00-1
Grill	
Air Intake elbow and hose	
Replace.....	0174 00-1
Grill screen	
Power plant	
Replacement.....	0468 00-1
Grill support arm	
Power plant	
Replacement.....	0467 00-1
Grille	
Power plant	
Raise and lower	0464 00-1
Removal/installation	0465 00-1
Ground lead	
Auxiliary power (slave) receptacle	
M113A3, M1059A3, M1064A3, and M58	
Replacement.....	0379 00-1

INDEX, cont'd

<u>Subject</u>	<u>WP Sequence No.-Page No.</u>
Battery	
M577A3 and M1068A3	
Connect	0338 00-1
Disconnect	0338 00-1
Ground Strap (W12)	
M1068A3	
Replacement	0846 00-1
Guard	
Antenna	
Replacement	0575 00-1
Driver's Hatch Night Vision	
M58	
Replacement	0536 01-1
Headlight	
Replacement	0446 00-1
Smoke grenade launcher	
M113A3 and M1059A3 only	
Replacement	0455 00-1
H	
Hand Throttle Control Cable Assembly	
Replacement	0219 00-1
Handle and Arms	
Ramp Lock	
All Except M577A3 and M1068A3	
Replacement	0524 00-1
Harness	
Cascade Remote	
M1068A3	
Replacement	0847 00-1
Glow plug	
Replacement	0209 00-1
Trailer	
Replacement	0375 00-1
Harness W32	
M1068A3	
Replacement	0848 00-1
Headlight	
Blackout	
Repair	0306 00-1
Replacement	0305 00-1
Headlight guard	
Replacement	0446 00-1

INDEX, cont'd

<u>Subject</u>	<u>WP Sequence No.-Page No.</u>
Headlight high beam selector switch	
Replacement	0333 00-1
Headlights	
Service and infrared	
Repair	0304 00-1
Replacement	0303 00-1
Heat Exchanger	
Battery Box	
Replacement	0718 00-1
Battery Drawer	
M1064A3	
Replacement	0719 00-1
Heat shield	
Turbo exhaust pipe	
Left/right, replace	0226 00-1
Water/Ration	
Mount Bracket (M113A3 Only)	
Replace	0811 00-1
Power Cable (M113A3 Only)	
Replace	0810 00-1
Heater Control Box	
M3 NBC	
M577A3	
Replacement	0792 00-1
Heater control box	
M3 NBC	
M1068A3	
Replacement	0793 00-1
Heater Fuel Supply Hoses	
M113A3 and M58	
Replacement	0685 00-1
Heater Hoses and Fittings	
M3 NBC	
Replace	0784 00-1
Heaters and Controllers	
M3 NBC	
M113A3 Ambulances	
Replacement	0795 00-1
High beam indicator light doesn't work	0050 00-1
High beam selector switch	
Headlight	
Replacement	0333 00-1

INDEX, cont'd

<u>Subject</u>	<u>WP Sequence No.-Page No.</u>
Hinges	
Turbine access door	
M58	
Replacement.....	0487 00-1
Hold-open Hook	
Driver's Hatch	
M113A3, M1059A3, M1064A3, and M58	
Replacement.....	0532 00-1
Hold-Open Hook and Bumper	
Driver's Hatch	
M577A3 and M1068A3	
Replacement.....	0533 00-1
Hold-open hook and bumper	
Commander's cupola	
M113A3, M1059A3, M58, and M1064A3	
Replacement.....	0494 00-1
Hook and bumper	
Commander's cupola hold-open	
M113A3 and M1059A3	
Replacement.....	0494 00-1
Commander's hatch	
M577A3 and M1068A3	
Replacement.....	0501 00-1
Hook and bumpers	
Cargo hatch hold-open	
M113A3 and M1059A3	
Replacement.....	0474 00-1
Hook and Eye	
Towing	
Replacement.....	0443 00-1
Hopper hatch	
M58	
Replacement.....	0484 00-1
Hopper hatch lock assembly	
M58	
Replacement.....	0483 00-1
Horn and ground lead	
Replacement.....	0336 00-1
Horn does not work	0037 00-1
Horn switch	
All Except M58	
Replacement.....	0293 00-1

INDEX, cont'd

<u>Subject</u>	<u>WP Sequence No.-Page No.</u>
M58	
Replacement.....	0293 01-1
Hose	
Balance	
Replacement.....	0234 00-1
Battery Plate to Battery Plate	
Replacement.....	0722 00-1
Bulkhead to Ramp Cylinder	
Replacement.....	0665 00-1
Coolant Heater to Surge Tank	
Replacement.....	0725 00-1
Engine to battery box	
Replacement.....	0714 00-1
Fuel Pump Tee To Elbow	
Replacement.....	0721 00-1
Fuel Pump to Bulkhead Connection	
M113A3 , M1059A3, and M58	
Replacement.....	0691 00-1
Fuel return	
Engine	
Replacement.....	0201 00-1
Fuel supply	
Engine	
Replacement.....	0200 00-1
Fuel Tank to Fuel Pump	
M577A3 and M1068A3	
Replacement.....	0690 00-1
Personnel heater	
M577A3 and M1068A3	
Replacement.....	0700 00-1
Quick Disconnect to Adapter Access Plate	
Fog Oil Tank (M1059A3)	
Replace.....	0769 00-1
Hose, restriction indicator	
Air cleaner	
Replace.....	0172 00-1
Hoses	
Auxiliary power unit bulkhead-to-hull fuel supply	
M577A3 and M1068A3	
Replacement.....	0678 00-1
Auxiliary Power Unit Valve-to-bulkhead Fuel Supply	
M577A3 and M1068A3	
Replacement.....	0677 00-1

INDEX, cont'd

<u>Subject</u>	<u>WP Sequence No.-Page No.</u>
■ Filter Fuel Supply	
M113A3, M1059A3, and M58	
Replacement.....	0685 00-1
Fuel Vent	
M577A3 and M1068A3	
Replace.....	0198 00-1
Heater Fuel Supply	
■ M113A3, M1059A3, and M58	
Replacement.....	0685 00-1
M13 NBC heater	
M1068A3 only	
Replace.....	0790 00-1
Thermostat	
Replacement.....	0238 00-1
Transmission oil supply and return	
Replacement.....	0251 00-1
Hoses from thermostat to	
Variable speed drive	
Replacement.....	0250 00-1
Hoses	
■ Thermostat.....	0250 00-1
Hoses from thermostat to variable speed drive	
Replacement.....	0250 00-1
Hoses, Tubes, and Fittings	
Fuel Supply	
M1064A3	
Replacement.....	0194 00-1
■ M113A3, M1059A3, and M58	
Replacement.....	0192 00-1
Hoses, tubes, and fittings	
Fuel supply	
M577A3 and M1068A3	
Replacement.....	0193 00-1
Hose	
Variable Speed Drive	
■ Override Switch.....	0251 00-1
How to Use Troubleshooting	
Introduction.....	0005 00-1
Hub	
Road wheel	
Replacement.....	0416 00-1
Hull	
Repair By Welding.....	0529 00-1

INDEX, cont'd

<u>Subject</u>	<u>WP Sequence No.-Page No.</u>
Hull drain plug	
Replacement	0451 00-1
Hull drain plugs	
Final drive	
Replacement	0452 00-1
Hull front access cover	
Replacement	0449 00-1
Hydraulic Reservoir	
Breather	
Service	0670 00-1
Hydraulic Hoses	
Power Plant	
Replacement	0668 00-1
Hydraulic Pump	
Ramp	
Replacement	0655 00-1
Hydraulic Reservoir	
Repair	0672 00-1
Hydraulic Reservoir	
Replacement	0671 00-1
Service	0669 00-1
I	
Idler Arm	
Replacement	0246 00-1
Idler wheel	
Replacement	0425 00-1
Idler wheel arm assembly	
Replacement	0417 00-1
Idler wheel arm bearings and seals	
Replacement	0418 00-1
Igniter	
Air Heater	
Replacement	0207 00-1
Replacement	0730 00-1
Ignition Coil	
Air Box	
Replacement	0208 00-1
Impact absorber	
Driver's Seat	
Replacement	0555 00-1
In blackout mode, fluorescent lights operate incorrectly	
M1068A3 only	0101 00-1

INDEX, cont'd

<u>Subject</u>	<u>WP Sequence No.-Page No.</u>
Indicator lights	
Replacement	0286 00-1
Infrared headlight(s) don't work	0032 00-1
Initial Installation of Litter Kit	
M113A3	0741 00-1
Inoperable ramp	
Lower	0513 00-1
Raise	0513 00-1
Instrument panel	
Battery-generator gauge, wiring harness	
Replacement	0289 00-1
Instrument panel and/or trans controller illumination lights malfunction	0038 00-1
Instrument Panel Assembly	
All Except M58	
Replacement	0279 00-1
Instrument panel Assembly	
M58	
Replacement	0279 01-1
Instrument panel gauges	
Replacement	0285 00-1
Instrument Panel Mounts and Ground Lead	
All Except M58	
Replacement	0295 00-1
M58	
Replacement	0295 01-1
Instrument panel on-off switches	
Replacement	0282 00-1
Instrument panel special purpose cable	
Replacement	0290 00-1
Instrument Warning Light Panel	
Replacement	0288 00-1
Insulation	
Battery Box	
Replacement	0718 00-1
Battery Drawer	
M1064A3	
Replacement	0719 00-1
Intercom Amplifier	
M58	
Replace	0888 00-1
Intercommunications Set Control	
M58	
Replacement	0885 00-1

INDEX, cont'd

<u>Subject</u>	<u>WP Sequence No.-Page No.</u>
Interior Latch	
Driver's Hatch	
Replacement.....	0534 00-1
Interior latch	
Cargo hatch	
M113A3 and M1059A3	
Replacement.....	0475 00-1
Commander's cupola	
M113A3, M1059A3, M58, and M1064A3	
Replacement.....	0496 00-1
Commander's hatch	
M577A3 and M1068A3	
Replacement.....	0502 00-1
Interior Lock	
Driver's Hatch	
Replacement.....	0534 00-1
Interior release mechanisms	
Mortar hatch	
M1064A3	
Replacement.....	0481 00-1
Intervehicle power cable	
M577A3 and M1068A3	
Replacement.....	0381 00-1
Inverter	
Housing A2 Terminal Blocks TB1 and TB2	
M1068A3	
Replacement.....	0830 00-1
Inverter AC Cable (W5)	
Replacement/Repair	0839 00-1
Inverter DC Cable (W6)	
M1068A3	
Replacement.....	0840 00-1
J	
Jump Seat	
Commander's	
M113A3	
Replacement.....	0563 00-1
Junction Box	
Chemical Alarm	
M113A3	
Repair	0920 00-1

INDEX, cont'd

<u>Subject</u>	<u>WP Sequence No.-Page No.</u>
Power Cable/Alarm Cable, Chemical Alarm	
M113A3	
Replacement.....	0919 00-1
K	
Kit	
Initial Installation of Litter	
M113A3	0741 00-1
Kits	
Armor	
M113A3	
Installation	0748 00-1
Mine Armor	
M113A3	
Installation/Removal	0752 00-1
L	
Lamp	
Transmission range controller	
Replacement.....	0388 00-1
LAN (M1068A3)	
Ground Box Assembly A15	
Repair	0821 00-1
Replace.....	0820 00-1
LAN A or B Cable	
(W103/W104)	
M1068A3	
Replacement.....	0854 00-1
LAN Cable (W40) Single Point	
M1068A3	
Replacement.....	0851 00-1
Latch	
Interior	
Driver's Hatch	
Replacement.....	0338 00-1
Lead	
Battery ground	
M577A3 and M1068A3	
Connect	0338 00-1
Disconnect	0338 00-1
Horn and ground	
Replacement.....	0336 00-1
Power Control Enclosure Circuit 44A	
M1068A3	
Replacement.....	0829 00-1

INDEX, cont'd

<u>Subject</u>	<u>WP Sequence No.-Page No.</u>
Lead (circuit 49)	
Master switch to distribution box	
M113A3 , M1059A3, M1064A3, and M58 only	
Replacement.....	0266 00-1
M577A3 and M1068A3 only	
Replacement.....	0267 00-1
Lead (circuit 50)	
Master switch to auxiliary power receptacle	
M113A3 , M1059A3, M1064A3, and M58	
Replacement.....	0268 00-1
Lead assembly	
Master switch panel dome lights	
M577A3 and M1068A3	
Replacement.....	0380 00-1
Utility outlet	
M577A3 and M1068A3	
Replacement.....	0377 00-1
Leads and terminals	
Battery	
M113A3 and M1059A3	
Replacement.....	0340 00-1
M577A3 and M1068A3	
Replacement.....	0341 00-1
M58	
Replacement.....	0345 00-1
Leads and terminals (left side)	
Battery	
M1064A3	
Replacement.....	0343 00-1
Leads and terminals (right side)	
Battery	
M1064A3	
Replacement.....	0344 00-1
Left Air Box	
Drain Check Valve and tubes	
Replace.....	0159 00-1
Left Bulkhead Radio Stowage Racks	
M577A3 and M1068A3	
Replacement.....	0577 00-1
Left front armor plate	
Replacement.....	0447 00-1
Left rear utility outlet/blower does not work	
M577A3 and M1068A3 only	0043 00-1

INDEX, cont'd

<u>Subject</u>	<u>WP Sequence No.-Page No.</u>
Left Side Rack Base	
M1068A3	
Replacement.....	0616 00-1
Left side spall liners	
M113A3	
Replacement.....	0505 00-1
Left stop light - tail light	
M577A3 and M1068A3	
Replacement.....	0299 00-1
Repair 0300 00-1	
Left Table	
M577A3	
Replacement.....	0578 00-1
Lens	
Dome light	
All Except M577A3 and M1068A3	
Replacement.....	0313 00-1
Lever	
Throttle valve (TV)	
Replacement.....	0218 00-1
Lever and Cable	
Ramp Lock	
M577A3 and M1068A3	
Replacement.....	0525 00-1
Lid and Latches	
External Communication Box A11	
Replace (M1068A3)	0818 00-1
Lifting Eye	
Replacement.....	0444 00-1
Light	
Blackout marker	
Repair.....	0308 00-1
Replacement.....	0307 00-1
Dome	
All Except M577A3 and M1068A3	
Repair.....	0310 00-1
Replacement.....	0309 00-1
M577A3 and M1068A3	
Repair.....	0312 00-1
Replacement.....	0311 00-1

INDEX, cont'd

<u>Subject</u>	<u>WP Sequence No.-Page No.</u>
Light Assemblies	
Fluorescent	
M1068A3	
Replacement.....	0825 00-1
Light Assembly	
Tent	
M577A3 and M1068A3	
Replacement.....	0318 00-1
Light Indicators	
Power Control Enclosure AC and DC	
M1068A3	
Replacement.....	0827 00-1
Light panel	
Instrument warning	
Replacement.....	0288 00-1
Light switch	
Main	
Replacement.....	0283 00-1
Lights	
Indicator	
Replacement.....	0286 00-1
Instrument Panel Warning	
Replacement.....	0287 00-1
Panel	
Replacement.....	0286 00-1
Warning Panel	
M58	
Replacement.....	0294 01-1
Warning panel	
All Except M58	
Replacement.....	0294 00-1
Linkage	
Accelerator	
Adjust	0214 00-1
Fuel Control	
Replacement.....	0217 00-1
Ramp	
M1064A3	
Replacement.....	0528 00-1
M113A3 and M1059A3	
Replacement.....	0526 00-1
M577A3 and M1068A3	
Replacement.....	0527 00-1

INDEX, cont'd

<u>Subject</u>	<u>WP Sequence No.-Page No.</u>
Steering wheel	
Adjustment	0427 00-1
Replacement	0430 00-1
Litter Kit	
Initial Installation of	
M113A3	0741 00-1
Lock	
Interior	
Driver's Hatch	
Replacement	0534 00-1
Ramp	
M1064A3	
Adjustment	0523 00-1
M113A3 and M1059A3	
Adjustment	0521 00-1
M577A3 and M1068A3	
Adjustment	0522 00-1
Lock assembly	
Hopper hatch	
M58	
Replacement	0483 00-1
Locks and Seals	
Vision Block	
Driver's Hatch	
Replacement	0535 00-1
Loop and strap	
Water barrier	
M113A3, M577A3, and M1068A3 only	
Replacement	0457 00-1
Loops	
Tool Box	
Replacement	0571 00-1
Lower Fuel Line	
Air Box Heater	
Replacement	0206 00-1
M	
M114 NBC Hoses and Brackets	
Replace	0783 00-1
M13 Air purifier and frame	
M1068A3 only	
Replace	0779 00-1
M13 NBC Filter	
Mount Bracket	

INDEX, cont'd

<u>Subject</u>	<u>WP Sequence No.-Page No.</u>
M577A3	
Replacement.....	0803 00-1
Switch	
M577A3	
Replacement.....	0803 00-1
M13 NBC Filter switch	
M1068A3 only	
Replace.....	0805 00-1
M13 NBC Filters and Hoses	
Replace	0786 00-1
M13 NBC Filters and hoses	
M1068A3 only	
Replace.....	0789 00-1
M13 NBC Heater	
Wiring Harness	
M577A3	
Replacement.....	0808 00-1
M13 NBC heater hoses	
M1068A3 only	
Replace.....	0790 00-1
M13 NBC Heater wiring harness	
M1068A3 only	
Replace.....	0809 00-1
M13 NBC Heaters	
M1068A3	
Replacement.....	0798 00-1
M13 Orifice connector assembly, bracket, and quick coupling half	
M1068A3 only	
Replace	0781 00-1
M14 NBC Cables and switch assembly	
M1059A3	
Replacement.....	0799 00-1
M14 NBC Heater	
Wiring Harness	
(M113A3 Ambulance)	
Replace.....	0807 00-1
M3 NBC Heater	
Bracket	
M113A3	
Replacement.....	0791 00-1
Control box	
M113A3	
Replace.....	0791 00-1

INDEX, cont'd

<u>Subject</u>	<u>WP Sequence No.-Page No.</u>
Regulator	
M113A3	
Replacement.....	0791 00-1
Wiring Harness (M1059A3)	
Replace.....	0806 00-1
M3 NBC Heater Control Box	
M577A3	
Replacement.....	0792 00-1
M3 NBC Heater control box	
M1068A3	
Replacement.....	0793 00-1
M3 NBC Heater Hoses and Fittings (M113A3 Ambulance)	
Replace	0784 00-1
M3 NBC Heaters and Controllers	
M113A3 Ambulances	
Replacement.....	0795 00-1
M3 NBC Hoses and Fittings	
Replace	0788 00-1
M43 Unit Interface Wiring Harnesses	
Chemical Alarm	
M113A3	
Replacement.....	0923 00-1
M8A3 NBC Cables, Switch Assembly, and Brackets	
M577A3	
Replacement.....	0801 00-1
M8A3 NBC Hoses and Brackets	
Replace.....	0785 00-1, 0787 00-1
M8A3/M14 Orifice connector assembly, support, and quick coupling half	
M113A3, M1059A3, and M577A3 only	
Replace.....	0780 00-1
M8A3/M3 NBC Filter	
Switch Assembly (M1059A3)	
Replace.....	0804 00-1
Machine gun mount	
Commander's cupola	
M113A3, M1059A3, M58, and M1064A3	
Repair	0498 00-1
Replacement.....	0497 00-1
Machine gun mount stops	
Commander's cupola	
M1059A3	
Replacement.....	0499 00-1
Main light switch	

INDEX, cont'd

<u>Subject</u>	<u>WP Sequence No.-Page No.</u>
Replacement	0283 00-1
Maintenance Allocation Chart (MAC)	0925 00-1
Malfunction/Symptom Index	0006 00-1
Map Board	
M1068A3	
Replacement	0618 00-1
M577A3	
Replacement	0580 00-1
Map Storage Box	
M1068A3	
Repair	0620 00-1
Replacement	0619 00-1
Master switch	
M113A3 , M1059A3, M1064A3, and M58 only	
Replacement	0262 00-1
Master switch on indicator doesn't light	0048 00-1
Master switch panel	
M113A3 , M1059A3, M1064A3, and M58	
Replacement	0260 00-1
M577A3 and M1068A3 only	
Replacement	0261 00-1
Master switch panel dome lights lead assembly	
M577A3 and M1068A3	
Replacement	0380 00-1
Master switch to auxiliary power receptacle lead (circuit 50)	
M113A3 , M1059A3, M1064A3, and M58	
Replacement	0268 00-1
Master switch to distribution box lead (circuit 49)	
M113A3 , M1059A3, M1064A3, and M58 only	
Replacement	0266 00-1
M577A3 and M1068A3 only	
Replacement	0267 00-1
Materials and Expendable Supplies List	0928 00-1
Meters	
Power Control Enclosure AC and DC	
M1068A3	
Replacement	0827 00-1
Modulator	
Throttle valve (TV)	
Replacement	0218 00-1
Mortar hatch covers	
M1064A3	
Replacement	0482 00-1

INDEX, cont'd

<u>Subject</u>	<u>WP Sequence No.-Page No.</u>
Mortar hatch exterior catches and bumpers	
M1064A3	
Replacement.....	0480 00-1
Mortar hatch interior release mechanisms	
M1064A3	
Replacement.....	0481 00-1
Mount	
Dome light	
M577A3 and M1068A3	
Repair.....	0312 00-1
Driver's Hatch Night Vision	
M58	
Replacement.....	0537 01-1
Fire Extinguisher	
M1059A3	
Replacement.....	0896 00-1
Fire Extinguisher, Portable	
All Except M1068A3	
Replacement.....	0895 00-1
M1068A3	
Replacement/Repair	0897 00-1
M1068A3	
Replacement.....	0834 00-1
Shock absorber	
Replacement.....	0436 00-1
Track tension adjuster	
Replacement.....	0419 00-1
Mount and Bracket	
APIU Rack	
M1068A3	
Replacement.....	0813 00-1
Mount Bracket	
M13 NBC Filter	
M577A3	
Replacement.....	0803 00-1
Water/Ration Heater	
(M113A3 Only)	
Replace.....	0811 00-1
Mounting	
Pamphlet bag	
Repair	0442 00-1
Mounting Blocks	

INDEX, cont'd

<u>Subject</u>	<u>WP Sequence No.-Page No.</u>
Fuel Valve	
All Except M577A3 and M1068A3	
Replacement.....	0199 00-1
Mounting Bracket	
Commander's Display (DVE)	
M58	
Replacement.....	0866 06-1
Driver's Display (DVE)	
M58	
Replacement.....	0866 02-1
Glow Plug Controller	
Replacement.....	0212 00-1
Mounting Bracket, and Switch	
NBC Orifice Connector Assembly	
M58	
Replacement.....	0916 00-1
Mounts	
Transmission	
Replacement.....	0385 00-1
Mounts and Ground Lead	
Instrument Panel	
All Except M58	
Replacement.....	0295 00-1
M58	
Replacement.....	0295 01-1
Mounts, Engine	
Replace.....	0158 00-1
Muffler	
Bracket	
Replace.....	0224 00-1
Muffler Extension and Cap	
Replacement.....	0223 00-1
N	
NATO Auxiliary power (slave) receptacle	
M577A3 and M1068A3 only	
Replacement.....	0264 00-1
NBC	
Air Purifier and Frame	
M113A3	
Replace.....	0775 00-1
M58	
Replacement.....	0914 00-1
Cable Assembly	

INDEX, cont'd

<u>Subject</u>	<u>WP Sequence No.-Page No.</u>
M58	
Removal/Installation	0917 00-1
Cable to Heaters, Air Purifier, and Switch	
M113A3	
Replacement.....	0800 00-1
Hose Assemblies	
M58	
Removal/Installation	0915 00-1
NBC Brackets	
M8A3	
M577A3	
Replacement.....	0801 00-1
NBC Cables	
M8A3	
M577A3	
Replacement.....	0801 00-1
NBC Filter	
Mount Bracket	
M577A3	
Replacement.....	0803 00-1
Switch	
Replacement.....	0803 00-1
Switch Assembly	
M113A3 and M113A3 Ambulance	
Replacement.....	0802 00-1
NBC Filter switch	
M13	
M1068A3 only	
Replace.....	0805 00-1
NBC Filters and hoses	
M13	
M1068A3 only	
Replace.....	0789 00-1
NBC Heater	
Hoses and Fittings	
Replace.....	0782 00-1
NBC Heater Control Box	
M3	
M577A3	
Replacement.....	0792 00-1
NBC Heater control box	
M3	
M1068A3	

INDEX, cont'd

<u>Subject</u>	<u>WP Sequence No.-Page No.</u>
Replacement.....	0793 00-1
NBC Heater Hoses and Fittings	
Replace	0782 00-1
NBC Heater wiring harness	
M13	
M1068A3 only	
Replace.....	0809 00-1
NBC Heaters	
M13	
M1068A3	
Replacement.....	0798 00-1
NBC Heaters and Controllers	
M113A3	
Replacement.....	0794 00-1
M3	
M113A3 Ambulances	
Replacement.....	0795 00-1
NBC kit	
M14	
Air purifier and frame (M113A3)	
Replace.....	0774 00-1
M8A3	
Air purifier and frame with M3 heater kit (M1059A3)	
Replace.....	0778 00-1
NBC Air purifier and frame (M1059A3)	
Replace.....	0777 00-1
M8A3/M13	
Air purifier and frame (M577A3)	
Replace.....	0776 00-1
NBC Kits	
NBC Heaters and Mounts	
M1059A3	
Replacement.....	0797 00-1
M577A3	
Replacement.....	0796 00-1
NBC Orifice Connector Assembly	
Mounting Bracket, and Switch	
M58	
Replacement.....	0916 00-1
NBC Orifice Connector Assembly, Mounting Bracket, and Switch	
M58	
Replacement.....	0916 00-1
NBC Switch Assembly	

INDEX, cont'd

<u>Subject</u>	<u>WP Sequence No.-Page No.</u>
M8A3	
M577A3	
Replacement.....	0801 00-1
Night vision guard	
Driver's Hatch	
M58	
Replacement.....	0536 01-1
Night vision mount	
Driver's Hatch	
M58	
Replacement.....	0537 01-1
No AC power from inverters	
M1068A3 only	0109 00-1
No AC power from tent interface panel A5	
M1068A3 only	0091 00-1
No AC/DC input to ATCCS UPS power box	
M1068A3 only	0100 00-1
No data output from data panel A12	
M1068A3 only	0110 00-1
No data output from data panel A13	
M1068A3 only	0112 00-1
No DC output from DC power supply	
M1068A3 only	0108 00-1
No DC power from tent interface panel A5	
M1068A3 only	0092 00-1
No DC power to single point LAN ground box A15	
M1068A3 only	0097 00-1
No exterior lights operate	0029 00-1
No LAN output from data panel A12	
M1068A3 only	0111 00-1
No LAN output from data panel A13	
M1068A3 only	0113 00-1
No power from curbside AC power extension box A7	
M1068A3 only	0094 00-1
No power from curbside UPS power extension box A19	
M1068A3 only	0099 00-1
No power from DC power extension box A9 (all except jack J23)	
M1068A3 only	0095 00-1
No power from DC power extension box A9, jack J23 (JTIDS)	
M1068A3 only	0096 00-1
No power from roadside AC power extension box A6	
M1068A3 only	0093 00-1
No power from UPS power extension box A18	

INDEX, cont'd

<u>Subject</u>	<u>WP Sequence No.-Page No.</u>
M1068A3 only	0098 00-1
No power to AC circuits	
M1068A3 only	0107 00-1
No power to DC circuits	
M1068A3 only	0106 00-1
Nomenclature Cross-Reference List.....	0001 00-10
Non-skid plates	
M1064A3	
Replacement.....	0738 00-1
O	
Oil	
Cooler hoses, fittings, and mounting	
Transmission	
Replacement.....	0399 00-1
Filter element, engine, Replace.....	0165 00-1
Gauge rod/tube, engine, Replace.....	0164 00-1
Oil and Oil Filter Element	
Transmission	
Replacement.....	0398 00-1
Oil can bracket	
Replacement.....	0574 00-1
Oil drain tubes and bracket	
Transmission	
Replacement.....	0384 00-1
Oil high temperature switch	
Transmission	
Replacement.....	0322 00-1
Oil low pressure transmitter and hardware	
Engine	
Replacement.....	0320 00-1
Oil seal	
Differential	
Final drive	
Replacement.....	0404 00-1
Final drive differential	
Replacement.....	0404 00-1
Oil Tank Module	
Fog	
M1059A3	
Replacement.....	0753 00-1
On cargo hatch cover	
Spall liner	
M113A3	

INDEX, cont'd

<u>Subject</u>	<u>WP Sequence No.-Page No.</u>
Replacement.....	0509 00-1
On ramp	
Spall liner	
M113A3	
Replacement.....	0512 00-1
On ramp door	
Spall liner	
M113A3	
Replacement.....	0511 00-1
On-off switches	
Instrument panel	
Replacement.....	0282 00-1
Operator's Intercommunication Set Cable	
M58	
Replacement.....	0894 00-1
Operator's Seat	
M1059A3	
Replacement/Repair.....	0567 00-1
Orifice connector assembly	
M8A3/M14	
M113A3, M1059A3, and M577A3 only	
Replace.....	0780 00-1
Orifice connector assembly, support, and quick coupling half	
M8A3/M14	
M113A3, M1059A3, and M577A3 only	
Replace.....	0780 00-1
Orifice connector support	
M8A3/M14	
M113A3, M1059A3, and M577A3 only	
Replace.....	0780 00-1
Orifice support quick coupling half	
M8A3/M14	
M113A3, M1059A3, and M577A3 only	
Replace.....	0780 00-1
Outlet Tube and Hoses	
Radiator	
Replacement.....	0233 00-1
P	
Pad	
Cushioning	
Replacement.....	0570 00-1
Track shoe	
Replacement.....	0424 00-1

INDEX, cont'd

<u>Subject</u>	<u>WP Sequence No.-Page No.</u>
Pamphlet bag mounting	
Repair	0442 00-1
Panel	
A13, Roadside Data	
M1068A3	
Replacement.....	0835 00-1
Master switch	
M113A3, M1059A3, M1064A3, and M58	
Replacement.....	0260 00-1
M577A3 and M1068A3 only	
Replacement.....	0261 00-1
Warning Light	
All Except M58	
Replacement.....	0292 00-1
Warning light assembly	
All Except M58	
Replacement.....	0291 00-1
Panel Assembly	
Instrument	
All Except M58	
Replacement.....	0279 00-1
M58	
Replacement.....	0279 01-1
Panel lights	
Replacement	0286 00-1
Parking brake	
Adjustment	0408 00-1
Parking brake bracket	
Replacement	0331 00-1
Parking brake control cable assembly	
Replacement	0411 00-1
Parking brake control lever assembly	
Replacement	0412 00-1
Parking brake indicator malfunctions.....	0052 00-1
Parking brake switch	
Replacement	0331 00-1
Pedal	
Accelerator, Lower	
Replacement.....	0215 00-1
Service brake	
Upper and lower	
Replacement.....	0409 00-1
Pedal Assembly	

INDEX, cont'd

<u>Subject</u>	<u>WP Sequence No.-Page No.</u>
Accelerator, Upper	
Replacement.....	0216 00-1
Personnel Heater	
Control Box Bracket	
M1068A3	
Replacement.....	0617 00-1
Duct	
Repair.....	0707 00-1
Duct and Hoses	
Replacement.....	0706 00-1
Intercom Box Bracket	
M1068A3	
Replacement.....	0617 00-1
Personnel heater	
Fuel filter	
Bracket M113A3, M1059A3, and M58	
Replacement.....	0698 00-1
M113A3, M1059A3, and M58	
Replacement.....	0698 00-1
Fuel pump	
M1064A3	
Replacement.....	0697 00-1
M577A3 and M1068A3	
Replacement.....	0696 00-1
Fuel pump hose	
M113A3, M1059A3, and M58	
Replacement.....	0689 00-1
Fuel pump to bulkhead connection hose	
M577A3 AND M1068A3	
Replacement.....	0692 00-1
Fuel pump to fuel shutoff valve hose	
M1064A3	
Replacement.....	0694 00-1
Personnel Heater Assembly	
All Except M1064A3	
Replacement.....	0703 00-1
M1064A3	
Replacement.....	0704 00-1
Repair	0705 00-1
Personnel Heater Fuel Filter	
Service	0680 00-1
Personnel Heater Fuel Pump	
M113A3, M1059A3, and M58	

INDEX, cont'd

<u>Subject</u>	<u>WP Sequence No.-Page No.</u>
Replacement.....	0695 00-1
Service	0681 00-1
Personnel Heater Fuel Tube	
All Except M1064A3	
Replacement.....	0686 00-1
Personnel heater malfunctions	0086 00-1
Personnel Seats, backrests, cushions and belts	
M1059A3	
Replacement.....	0549 00-1
M1064A3	
Replacement.....	0550 00-1
Personnel seats, cushions, and belts	
M113A3	
Replacement.....	0546 00-1
M577A3	
Replacement.....	0547 00-1
Phone extension box A14 post(s) inoperative	
M1068A3 only	0114 00-1
Pin	
Shock absorber	
Replacement.....	0437 00-1
Pintle	
Towing	
Repair	0434 00-1
Replacement.....	0433 00-1
Pipes	
Coolant Heater Exhaust	
Replacement.....	0724 00-1
Front Bilge Pump	
Replace.....	0631 00-1
Rear Bilge Pump	
Replacement.....	0634 00-1
Plate	
Smoke grenade launcher	
M113A3 and M1059A3 only	
Replacement.....	0455 00-1
Plates	
Non-skid	
M1064A3	
Replacement.....	0738 00-1
Platform	
Commander's	
M113A3, M1059A3, M1064A3, and M58	

INDEX, cont'd

<u>Subject</u>	<u>WP Sequence No.-Page No.</u>
Replacement/repair	0559 00-1
M577A3 and M1068A3	
Replacement/Repair	0564 00-1
Plug	
Hull drain	
Replacement	0451 00-1
Portable Fire Extinguisher Mount	
All Except M1068A3	
Replacement	0895 00-1
M1068A3	
Replacement/Repair	0897 00-1
Post	
Commander's	
M113A3, M1059A3, and M58	
Replacement	0560 00-1
M577A3 and M1068A3	
Replacement/Repair	0564 00-1
Commander's seat	
M1064A3	
Replacement	0561 00-1
Post Assembly	
Driver's Seat	
Replacement	0556 00-1
M113A3	
Replacement	0742 00-1, 0743 00-1
Power Cable	
Chemical Alarm	
M113A3	
Replacement	0919 00-1
DVE Sensor Set Assembly	
M58	
Replacement	0866 01-1
Water/Ration Heater	
(M113A3 Only)	
Replace	0810 00-1
Power cable	
Intervehicle	
M577A3 and M1068A3	
Replacement	0381 00-1
Power Control Enclosure	
AC and DC Light Indicators	
M1068A3	
Replacement	0827 00-1

INDEX, cont'd

<u>Subject</u>	<u>WP Sequence No.-Page No.</u>
AC and DC Meters	
M1068A3	
Replacement.....	0827 00-1
Bracket	
M1068A3	
Repair.....	0828 00-1
Circuit 44A Lead	
M1068A3	
Replacement.....	0829 00-1
Faceplate	
M1068A3	
Repair.....	0828 00-1
Power control enclosure A1 DC input/output inoperative	
M1068A3 only	0090 00-1
Power Control Enclosure Assembly	
A1	
M1068A3	
Replacement.....	0826 00-1
Power Distribution Box A3	
M1068A3	
Replacement/Repair	0831 00-1
Power Distribution Cable (W3)	
M1068A3	
Replacement.....	0837 00-1
Power Entry Box Assembly A4	
M1068A3	
Replacement.....	0832 00-1
Power Extension	
Box A18, AC	
M1068A3	
Replacement.....	0836 00-1
Power Extension Box A18 and Bracket	
M1068A3	
Replacement.....	0836 00-1
Power Harness	
Glow Plug	
Replacement.....	0211 00-1
Power Plant	
Block	0157 00-1
Hydraulic Hoses	
Replacement.....	0668 00-1

INDEX, cont'd

<u>Subject</u>	<u>WP Sequence No.-Page No.</u>
Power plant access panel	
Driver's	
Replacement.....	0441 00-1
Power plant assembly	
Removal/Installation	0156 00-1
Power plant bottom access cover	
Replacement.....	0450 00-1
Power plant door	
All except M113A3	
Replacement.....	0471 00-1
M113A3	
Replacement.....	0470 00-1
Repair.....	0472 00-1
Power plant door combat lock	
Replacement.....	0473 00-1
Power plant grill screen	
Replacement.....	0468 00-1
Power plant grill support arm	
Replacement.....	0467 00-1
Power plant grille	
Raise and lower.....	0464 00-1
Removal/installation.....	0465 00-1
Power plant rear access panels	
Repair/Replacement	0439 00-1
Power Plant Sling	
Inspect	0673 00-1
Power Supply	
Storage Box Assembly	
M1068A3	
Replacement/Repair	0824 00-1
Power supply	
Solid state infrared	
Replacement.....	0297 00-1
Power Supply Cable	
Driver's Vision Enhancer (DVE) AN/VAS-5	
M58	
Replacement.....	0866 04-1
Power supply cable assembly	
Driver's night vision (DNV) (AN/VVS-2)	
All Except M58	
Replacement.....	0368 00-1
Pressure switch	
Differential	

INDEX, cont'd

<u>Subject</u>	<u>WP Sequence No.-Page No.</u>
Bypass plug	
Replacement.....	0401 00-1
Transmission oil	
Replacement.....	0400 00-1
Preventive Maintenance Checks and Services (PMCS), Including Lubrication Instructions	
Annual	0155 00-1
Semi-Annual.....	0155 00-1
Principles of Operation	
Auxiliary Automotive System.....	0003 00-2
Special Equipment.....	0003 00-3
Winterization Equipment	0003 00-3
Printer Mount	
Replace/Repair	0823 00-1
Propeller shaft and universal joints	
Replacement.....	0405 00-1
Pulley	
Coolant Pump Idler	
Replacement.....	0240 00-1
Ventilating Fan Drive	
Replacement.....	0244 00-1
Pulse Tachometer	
STE/ICE	
Replacement.....	0867 00-1
Pump	
Coolant Heater	
Replacement.....	0731 00-1
Engine Coolant	
Replacement.....	0241 00-1
Hydraulic	
Ramp	
Replacement.....	0655 00-1
Pump Assembly	
Fog Oil	
(M1059A3 Only)	
Replace.....	0763 00-1
Pump Unit	
Coolant Heater	
Replace.....	0728 00-1
Push-pull control assembly, bracket, links, and pins (cable-activated lock)	
Replacement.....	0429 00-1

INDEX, cont'd

<u>Subject</u>	<u>WP Sequence No.-Page No.</u>
Q	
Quick coupling half	
M13 Orifice	
M1068A3 only	
Replace.....	0781 00-1
M8A3/M14 Orifice support	
M113A3, M1059A3, and M577A3 only	
Replace.....	0780 00-1
Quick release pin and lanyard	
Replacement.....	0431 00-1
Quick release pins and plates	
Spall liner	
M113A3	
Repair.....	0506 00-1
R	
Rack	
Radio	
M58	
Replace.....	0891 00-1
Radio stowage	
M1064A3	
Replacement.....	0609 00-1
Rifle	
M1064A3	
Replacement.....	0612 00-1
Rack Assembly	
Rack Base	
Right Side	
M1068A3	
Replacement.....	0622 00-1
Racks	
Left Bulkhead Radio Stowage	
M577A3 and M1068A3	
Replacement.....	0577 00-1
Radiac wire harness	
M113A3, M577A3, and M1068A3	
Replacement.....	0376 00-1
Radiator	
Clean	0228 00-1
Radiator access door	
Replacement.....	0469 00-1
Radiator and Parts	
Replacement.....	0229 00-1

INDEX, cont'd

<u>Subject</u>	<u>WP Sequence No.-Page No.</u>
Radiator Outlet Tube and Hoses	
Replacement	0233 00-1
Radio Operator's Seat	
M1068A3 and M58	
Replacement/Repair	0568 00-1
Radio Rack	
M58	
Replace	0891 00-1
Radio Stowage Rack	
Right Front	
M577A3	
Replacement	0579 00-1
Radio Stowage Racks	
Left Bulkhead	
M577A3 and M1068A3	
Replacement	0577 00-1
Radio(s) don't work	0044 00-1
Ramp	
Bracket	
M113A3, M577A3, and M1068A3	
Replacement	0516 00-1
Control Valve	
Elbow	
Replacement	0663 00-1
Hose	
Replacement	0663 00-1
Replacement	0660 00-1
Control Valve (with Internal Relief Valve) and Fittings	
Replacement	0661 00-1
Control Valve and Fittings (with External Relief Valve)	
Replacement	0659 00-1
Cylinder	
Replacement	0656 00-1
Cylinder Breather Hose	
All Except M1064A3	
Replacement	0666 00-1
M1064A3	
Replacement	0667 00-1
Door	
Stop Bracket	
Replacement	0517 00-1
External Relief Valve	
Replacement	0660 00-1

INDEX, cont'd

<u>Subject</u>	<u>WP Sequence No.-Page No.</u>
Fittings with Ramp Control Valve (Internal Relief Valve)	
Replacement.....	0660 00-1
Hose	
Bulkhead to Cylinder	
Replacement.....	0665 00-1
Hydraulic Pump	
Replacement.....	0655 00-1
Linkage	
M1064A3	
Replacement.....	0528 00-1
M113A3 and M1059A3	
Replacement.....	0526 00-1
M577A3 and M1068A3	
Replacement.....	0527 00-1
Lock	
M1064A3	
Adjustment.....	0523 00-1
M113A3 and M1059A3	
Adjustment.....	0521 00-1
M577A3 and M1068A3	
Adjustment.....	0522 00-1
Vision Port and Shield	
M58	
Replacement/Repair.....	0586 00-1
Ramp Door	
Handles	
Replacement.....	0519 00-1
Hook	
Replacement.....	0518 00-1
Seal	
Replacement.....	0520 00-1
Shaft	
Replacement.....	0519 00-1
Spring	
Replacement.....	0518 00-1
Ramp door switch and mount	
M577A3 and M1068A3	
Replacement.....	0335 00-1
Ramp drain plugs	
Replacement.....	0515 00-1

INDEX, cont'd

<u>Subject</u>	<u>WP Sequence No.-Page No.</u>
Ramp Lock	
Handle and Arms	
All Except M577A3 and M1068A3	
Replacement.....	0524 00-1
Lever and Cable	
M577A3 and M1068A3	
Replacement.....	0525 00-1
Ramp operation is slow or sluggish.....	0083 00-1
Ramp seal	
Replacement.....	0514 00-1
Ramp will not lower	0082 00-1
Ramp will not raise or free falls	0084 00-1
Range controller	
Bracket	
Used with solenoid-activated steering lock	
Replacement.....	0386 00-1
Transmission	
Used with cable-activated steering lock	
Replacement.....	0387 00-1
Used with solenoid-activated steering lock	
Replacement.....	0386 00-1
Range controller lamp	
Transmission	
Replacement.....	0388 00-1
Range controller switch	
Transmission	
Replacement.....	0389 00-1
Rear access panels	
Power plant	
Repair/Replacement.....	0439 00-1
Rear Armor	
M113A3	
Replacement.....	0751 00-1
Rear Bilge Pump	
Replacement.....	0635 00-1
Strainer	
Replacement.....	0635 00-1
Rear Bilge Pump Pipes	
Replacement.....	0634 00-1
Rear compartment air ventilator	
Replacement.....	0454 00-1

INDEX, cont'd

<u>Subject</u>	<u>WP Sequence No.-Page No.</u>
Rear dome light switch	
M577A3 and M1068A3	
Replacement.....	0315 00-1
Rear external stowage frame	
M1068A3	
Replacement.....	0626 00-1
Rear main wiring harness	
M1064A3	
Replacement.....	0364 00-1
M1068A3	
Replacement.....	0365 00-1
M113A3, M1059A3, and M58	
Replacement.....	0362 00-1
M577A3	
Replacement.....	0363 00-1
Rear tiedown plates	
Replacement.....	0445 00-1
Rear upper hull spall liner	
M113A3	
Replacement.....	0510 00-1
Rear utility outlet receptacles	
M577A3 and M1068A3	
Replacement.....	0378 00-1
Rear utility receptacle circuit breakers	
M577A3 and M1068A3 only	
Replacement.....	0276 00-1
Receptacle	
Auxiliary power (slave)	
M113A3 , M1059A3, M1064A3, and M58 only	
Replacement.....	0263 00-1
NATO Auxiliary power (slave)	
M577A3 and M1068A3 only	
Replacement.....	0264 00-1
Receptacles	
Rear utility outlet	
M577A3 and M1068A3	
Replacement.....	0378 00-1
Reel holder assembly	
Cable	
M1064A3	
Repair.....	0604 00-1

INDEX, cont'd

<u>Subject</u>	<u>WP Sequence No.-Page No.</u>
Reel holder assembly, cable	
M1064A3	
Replacement.....	0603 00-1
References	0924 00-1
Refill Tray Bracket	
Chemical Alarm	
M113A3	
Replacement.....	0922 00-1
Regulator	
Voltage	
Adjustment.....	0256 00-1
Regulator assembly	
Replacement.....	0257 00-1
Release	
Trim vane	
Repair	0463 00-1
Replacement.....	0462 00-1
Release mechanisms	
Mortar hatch interior	
M1064A3	
Replacement.....	0481 00-1
Restriction indicator	
Air cleaner	
Replace.....	0171 00-1
Retainer	
Batteries	
M1064A3	
Replacement.....	0349 00-1
Repair Parts, Special Tools, TMDE, and Support Equipment.....	0004 00-1
Rifle Brackets	
Replacement.....	0573 00-1
Rifle Rack	
M1064A3	
Replacement.....	0612 00-1
Right Equipment Rack	
Brackets and Mounts	
M1068A3	
Replacement.....	0814 00-1
Right Forward Table	
M577A3	
Replacement.....	0581 00-1
Right front armor plate	
Replacement.....	0448 00-1

INDEX, cont'd

<u>Subject</u>	<u>WP Sequence No.-Page No.</u>
Right Front Radio Stowage Rack	
M577A3	
Replacement.....	0579 00-1
Right headlight wiring harness	
Replace	0373 00-1
Right rear utility outlet/admittance buzzer works improperly	
M577A3 and M1068A3 only	0042 00-1
Right Rearward Table	
M577A3	
Replacement.....	0582 00-1
Right Side Base Extension	
M1068A3	
Replacement.....	0623 00-1
Right side spall liners	
M113A3	
Replacement.....	0504 00-1
Right stop light - tail light	
M577A3	
Replacement.....	0301 00-1
Repair.....	0302 00-1
Road wheel	
T130	
Replacement.....	0426 00-1
T150	
Replacement.....	0426 01-1
Road wheel hub	
Replacement.....	0416 00-1
Road wheel support arm, bearings, and seals	
Replacement.....	0415 00-1
Roadside Data Panel A13	
M1068A3	
Replacement.....	0835 00-1
S	
Safety pin stowage block	
Commander's cupola	
M113A3, M1059A3, M58, and M1064A3	
Replacement.....	0495 00-1
Safety Relief Valve	
Fittings	
Replacement.....	0662 00-1
Hose	
Replacement.....	0662 00-1

INDEX, cont'd

<u>Subject</u>	<u>WP Sequence No.-Page No.</u>
Tube	
Replacement.....	0662 00-1
Sampling valve	
Transmission oil	
Replacement.....	0400 00-1
Schematic	
All except M577A3 and M1068A3	
Engine fuel system.....	0009 00-1
Bilge pump.....	0078 00-1
Coolant heater.....	0087 00-1
Engine charging system.....	0007 00-1
Engine starter circuit.....	0011 00-1
Indicators.....	0046 00-1
STE/ICE.....	0136 00-1
Electrical.....	0027 00-1
(cable-activated lock)	
Steering lock.....	0075 00-1
Engine air box heater.....	0013 00-1
M577A3 and M1068A3	
Engine fuel system.....	0010 00-1
Personnel heater.....	0085 00-1
Ramp.....	0081 00-1
(solenoid-activated lock)	
Steering lock.....	0074 00-1
Transmission.....	0060 00-1
Seal	
Ramp	
Replacement.....	0514 00-1
Ramp Door	
Replacement.....	0520 00-1
Seals	
Cargo hatch	
M113A3 and M1059A3	
Replacement.....	0478 00-1
Idler wheel arm	
Replacement.....	0418 00-1
Road wheel support	
Replacement.....	0415 00-1
Seat	
Commander's	
M1064A3	
Replacement.....	0561 00-1

INDEX, cont'd

<u>Subject</u>	<u>WP Sequence No.-Page No.</u>
M1068A3	
Replacement/repair	0566 00-1
M113A3, M1059A3, and M58	
Replacement.....	0560 00-1
M113A3, M1059A3, M1064A3, and M58	
Repair	0562 00-1
Commander's Jump	
M113A3	
Replacement.....	0563 00-1
Driver's	
Post assembly	
Repair	0557 00-1
Repair	0552 00-1
Replacement.....	0551 00-1
Operator's	
M1059A3	
Replacement/Repair	0567 00-1
Personnel	
M1059A3	
Replacement.....	0549 00-1
M1064A3	
Replacement.....	0550 00-1
Radio Operator's	
M58	
Replacement/Repair	0568 00-1
Seats	
Personnel	
M113A3	
Replacement.....	0546 00-1
M577A3	
Replacement.....	0547 00-1
Sensors	
Switches	
Replace.....	0321 01-1
Sensor Set Assembly Adapter	
AN/VAS-5 Driver's Night Vision Enhancer (DVE)	
M58	
Replacement.....	0866 05-1
Service and infrared headlights	
Repair	0304 00-1
Replacement	0303 00-1
Service and/or black out stop lights malfunction	0033 00-1
Service and/or parking brake won't hold carrier.....	0064 00-1

INDEX, cont'd

<u>Subject</u>	<u>WP Sequence No.-Page No.</u>
Service brake control linkage	
Adjustment	0407 00-1
Replacement	0410 00-1
Service brake pedal	
Upper and lower	
Replacement	0409 00-1
Service headlights don't work	0031 00-1
Service tallight doesn't work	0035 00-1
Service Upon Receipt	0154 00-1
Shaft	
Fuel Control	
Replacement	0217 00-1
Shelf Assembly	
Right Side	
M1068A3	
Replacement	0621 00-1
Shield	
External Handle	
M1064A3	
Replacement	0903 00-1
M113A3 and M1059A3	
Replacement	0901 00-1
M577A3 and M1068A3	
Replacement	0902 00-1
Ramp Vision Port	
M58	
Replacement/Repair	0586 00-1
Shields, Armor, Commander's Cupola	
M113A3 and M1064A3	
Replacement	0747 00-1
Shock absorber	
Replacement	0435 00-1
Shock absorber mount	
Replacement	0436 00-1
Shock absorber pin	
Replacement	0437 00-1
Shunt	
STE/ICE	
M1064A3	
Replacement	0873 00-1
M113A3 and M1059A3	
Replacement	0870 00-1

INDEX, cont'd

<u>Subject</u>	<u>WP Sequence No.-Page No.</u>
M577A3 and M1068A3 Replacement.....	0871 00-1
Shunt Guard	
STE/ICE	
M113A3 and M1059A3 Replacement.....	0868 00-1
Shut-off Valve Assembly	
Fuel	
M113A3, M1059A3, and M58 Replacement.....	0684 00-1
Side Armor	
M113A3 Replacement.....	0750 00-1
Signal Patch Panel Box A10 Replace	0816 00-1
Sling	
Power Plant Inspect	0673 00-1
Smoke Generator	
Adapter Access Plate to Generator Electrical Cable Assembly M1059A3 Replacement.....	0761 00-1
Breather Hose Assembly M1059A3 Replacement.....	0754 00-1
Control Panel Assembly M1059A3 Replace.....	0756 00-1
Internal Cable Assembly M1059A3 Replacement.....	0760 00-1
M1059A3 Replacement.....	0755 00-1
Power Supply Cable Assembly M1059A3 Replacement.....	0757 00-1
Support Bracket M1059A3 Replacement.....	0755 00-1
Smoke Generator (M1059A3)	
Adapter Access Plate Gasket Replace.....	0766 00-1

INDEX, cont'd

<u>Subject</u>	<u>WP Sequence No.-Page No.</u>
Adapter Access Plate to Cover Assembly Air Hose	
Replace.....	0768 00-1
Air Hose	
Compressor Reservoir to Access Plate	
Replace.....	0767 00-1
Armor	
Replace.....	0771 00-1
Fuel Can Lid Assembly	
Replace.....	0764 00-1
Fuel Filter	
Replace.....	0773 00-1
Fuel Lines and Guards	
Replace.....	0765 00-1
Glow Plug Cable Assembly	
Replace.....	0772 00-1
Water Separator	
Replace.....	0773 00-1
Smoke grenade launcher guard, plate, and base	
M113A3 and M1059A3 only	
Replacement.....	0455 00-1
Smoke grenade launcher wiring harness	
M113A3 , M1059A3, and M58	
Replacement.....	0366 00-1
Smoke grenade launcher(s) malfunction	
M113A3 and M1059A3	0045 00-1
Solenoid, bracket, links, and pins (solenoid-activated lock)	
Steering lock	
Replacement.....	0428 00-1
Solenoid-activated steering lock malfunctions	0076 00-1
Solid state infrared power supply	
Replacement.....	0297 00-1
Spall liner	
Rear upper hull	
M113A3	
Replacement.....	0510 00-1
Spall liner and bracket	
Forward	
M113A3	
Replacement.....	0507 00-1
Spall liner on cargo hatch cover	
M113A3	
Replacement.....	0509 00-1

INDEX, cont'd

<u>Subject</u>	<u>WP Sequence No.-Page No.</u>
Spall liner on ramp	
M113A3	
Replacement.....	0512 00-1
Spall liner on ramp door	
M113A3	
Replacement.....	0511 00-1
Spall liner quick release pins and plates	
M113A3	
Repair.....	0506 00-1
Spall liners	
Forward upper right and left side	
M113A3	
Replacement.....	0508 00-1
Left side	
M113A3	
Replacement.....	0505 00-1
Right side	
M113A3	
Replacement.....	0504 00-1
Special purpose cable	
Instrument panel	
Replacement.....	0290 00-1
Speedometer	
Cable	
Adapter	
Replace.....	0860 00-1
Replace.....	0860 00-1
Service.....	0858 00-1
Replace.....	0859 00-1
Speedometer Cable	
Repair.....	0861 00-1
Speedometer malfunctions.....	0115 00-1
Spring Tensioner	
Idler Arm	
Replacement.....	0246 00-1
Start switch	
Engine	
Replacement.....	0284 00-1
Starter	
Replace.....	0259 00-1
Starter relay switch	
Replacement.....	0258 00-1

INDEX, cont'd

<u>Subject</u>	<u>WP Sequence No.-Page No.</u>
STE/ICE	
Pulse Tachometer	
Replacement.....	0867 00-1
Shunt	
M1064A3	
Replacement.....	0873 00-1
M113A3 and M1059A3	
Replacement.....	0870 00-1
M577A3 and M1068A3	
Replacement.....	0871 00-1
Shunt Guard	
M113A3 and M1059A3	
Replacement.....	0868 00-1
STE/ICE Crew Wiring Harness	
M1064A3	
Replacement.....	0881 00-1
M113A3 and M1059A3	
Replacement.....	0878 00-1
M577A3 and M1068A3	
Replacement.....	0879 00-1
STE/ICE Distribution Box	
M1064A3	
Replacement.....	0877 00-1
M113A3 and M1059A3	
Replacement.....	0874 00-1
M577A3 and M1068A3	
Replacement.....	0875 00-1
STE/ICE Engine Wiring Harness	
Replacement.....	0882 00-1
STE/ICE test set to DCA 6	
Hook up.....	0117 00-1
Remove.....	0117 00-1
Steering	
Transmission	
Adjust.....	0393 00-1
Steering lock solenoid, bracket, links, and pins (solenoid-activated lock)	
Replacement.....	0428 00-1
Steering Lock Switch	
Replacement.....	0330 00-1
Steering Lock Switch Wiring Harness	
All Except M58	
Replacement.....	0367 00-1

INDEX, cont'd

<u>Subject</u>	<u>WP Sequence No.-Page No.</u>
M58	
Replacement.....	0367 01-1
Steering locked indicator malfunctions	0054 00-1
Steering support, brackets, and shaft	
Replacement.....	0432 00-1
Steering wheel linkage	
Adjustment.....	0427 00-1
Replacement.....	0430 00-1
Stencils	
M1059A3	0640 00-1
M1064A3	0641 00-1
M1068A3	0642 00-1
M113A3	0636 00-1
M577A3	0637 00-1
M58	0643 00-1
Stop light - tail light	
Left	
M577A3 and M1068A3	
Replacement.....	0299 00-1
Repair.....	0300 00-1
Right	
M577A3	
Replacement.....	0301 00-1
Repair.....	0302 00-1
Stop light - tail light and guards	
All Except M577A3 and M1068A3	
Replacement.....	0298 00-1
Stop switch	
Replacement.....	0332 00-1
Storage Box Assembly	
Power Supply	
M1068A3	
Replacement/Repair	0824 00-1
Stowage	
Driver's Night Vision (AN/VVS-2)	
All Except M58	
Replacement.....	0572 00-1
Stowage Box	
M113A3	
Replacement.....	0750 00-1

INDEX, cont'd

<u>Subject</u>	<u>WP Sequence No.-Page No.</u>
Stowage box	
Grenade	
M1064A3	
Replacement.....	0610 00-1
Periscope	
M1064A3	
Replacement.....	0611 00-1
Stowage Bracket	
AN/VAS-5 Driver's Vision Enhancer	
M58	
Replacement.....	0866 03-1
Track shoe.....	0575 01-1
Sight Extension Arm	
M1064A3	
Replacement.....	0613 00-1
Stowage Brackets for W1, W2, and NATO Slave Cables	
M1068A3 and M577A3	
Replacement.....	0626 01-1
Stowage frame	
Rear external	
M1068A3	
Replacement.....	0626 00-1
Stowage Rack	
Right Front Radio	
M577A3	
Replacement.....	0579 00-1
Stowage Racks	
Left Bulkhead Radio	
M577A3 and M1068A3	
Replacement.....	0577 00-1
Strainer	
Front Bilge Pump	
Replace.....	0632 00-1
Rear Bilge Pump	
Replacement.....	0635 00-1
Strainer Parts	
Filler Cap	
All Except M577A3 and M1068A3	
Replacement.....	0184 00-1
M577A3 and M1068A3	
Replacement.....	0185 00-1

INDEX, cont'd

<u>Subject</u>	<u>WP Sequence No.-Page No.</u>
Straps	
Webbing	
Replacement.....	0569 00-1
Support	
Antenna	
M58	
Replacement.....	0602 00-1
M8A3/M14 Orifice connector	
M113A3, M1059A3, and M577A3 only	
Replace.....	0780 00-1
Support, brackets, and shaft	
Steering	
Replacement.....	0432 00-1
Switch	
Blower	
M577A3 and M1068A3 only	
Replacement.....	0278 00-1
Differential Pressure	
Replacement.....	0401 00-1
Dome blackout light bypass	
M577A3 and M1068A3	
Replacement.....	0317 00-1
Engine start	
Replacement.....	0284 00-1
Flame Detector	
Adjust.....	0727 00-1
Flame Detetor	
Coolant Heater	
Replacement.....	0734 00-1
Front dome light	
M577A3 and M1068A3	
Replacement.....	0314 00-1
Fuel Filter Differential Pressure	
Replacement.....	0328 00-1
Fuel selector	
M577A3 and M1068A3 only	
Replacement.....	0277 00-1
Generator field pressure	
Replacement.....	0323 00-1
Headlight high beam selector	
Replacement.....	0333 00-1
Horn	
Replacement.....	0293 00-1

INDEX, cont'd

<u>Subject</u>	<u>WP Sequence No.-Page No.</u>
M58	
Replacement.....	0293 01-1
Light	
Main	
Replacement.....	0283 00-1
M13 NBC Filter	
M577A3	
Replacement.....	0803 00-1
Parking brake	
Replacement.....	0331 00-1
Rear dome Light	
M577A3 and M1068A3	
Replacement.....	0315 00-1
Rear dome light	
M577A3 and M1068A3	
Replacement.....	0315 00-1
Starter relay	
Replacement.....	0258 00-1
Steering lock	
Replacement.....	0330 00-1
Stop	
Replacement.....	0332 00-1
Thermostatic Fan Speed	
Replacement.....	0231 00-1
Transmission Oil	
Replacement.....	0400 00-1
Transmission oil high temperature	
Replacement.....	0322 00-1
Transmission range controller	
Replacement.....	0389 00-1
Switch and buzzer	
Admittance	
M577A3 and M1068A3	
Replacement.....	0334 00-1
Switch and mount	
Ramp door	
M577A3 and M1068A3	
Replacement.....	0335 00-1
Switch Assembly	
M8A3/M3 NBC Filter (M1059A3)	
Replace.....	0804 00-1

INDEX, cont'd

<u>Subject</u>	<u>WP Sequence No.-Page No.</u>
NBC Filter	
M113A3 and M113A3 Ambulance	
Replacement.....	0802 00-1
Switch to gauge lead	
Fuel select	
All Except M577A3 and M1068A3	
Replacement.....	0281 00-1
Switches	
On-off	
Instrument panel	
Replacement.....	0282 00-1
T	
Table	
Left	
M577A3	
Replacement.....	0578 00-1
Right forward	
M577A3	
Replacement.....	0581 00-1
Right Rearward	
M577A3	
Replacement.....	0582 00-1
Tachometer	
Cable	
Repair.....	0865 00-1
Replace.....	0864 00-1
Service.....	0858 00-1
Engine adapter	
Replace.....	0863 00-1
Pulse	
STE/ICE	
Replacement.....	0867 00-1
Replace	0862 00-1
Tachometer malfunctions	0116 00-1
Taillight	
Bracket	
M1068A3	
Repair	0625 00-1
Replacement.....	0625 00-1
Wiring Harness	
M1068A3	
Repair	0625 00-1
Replacement.....	0625 00-1

INDEX, cont'd

<u>Subject</u>	<u>WP Sequence No.-Page No.</u>
Tank	
Auxiliary	
Replacement.....	0230 00-1
Tank Module	
Fog Oil	
M1059A3	
Replacement.....	0753 00-1
Teleposts and cover	
Replacement.....	0296 00-1
Tent	
Frame mounts	
M577A3	
Replacement.....	0628 00-1
M577A3	
Replacement.....	0627 00-1
Tent Interface Panel	
Box Assembly A5	
M1068A3	
Replacement.....	0833 00-1
Tent Light Assembly	
M577A3 and M1068A3	
Replacement.....	0318 00-1
Terminal Blocks TB1 and TB2	
Inverter Housing A2	
M1068A3	
Replacement.....	0830 00-1
Terminals and leads	
Battery	
M113A3 and M1059A3	
Replacement.....	0340 00-1
M577A3 and M1068A3	
Replacement.....	0341 00-1
M58	
Replacement.....	0345 00-1
Terminals and leads (left side)	
Battery	
M1064A3	
Replacement.....	0343 00-1
Terminals and leads (right side)	
Battery	
M1064A3	
Replacement.....	0344 00-1

INDEX, cont'd

<u>Subject</u>	<u>WP Sequence No.-Page No.</u>
Test 10 diagnostic troubleshooting	
STE/ICE	0140 00-1
Test 10 engine RPM	
STE/ICE	0118 00-1
Test 11 diagnostic troubleshooting	
STE/ICE	0140 00-1
Test 12 diagnostic troubleshooting	
STE/ICE	0140 00-1
Test 13 diagnostic troubleshooting	
STE/ICE	0140 00-1
Test 24 fuel supply pressure	
STE/ICE	0119 00-1
Test 24 fuel supply pressure diagnostic troubleshooting	
STE/ICE	0143 00-1
Test 25 fuel return pressure	
STE/ICE	0120 00-1
Test 25 fuel return pressure diagnostic troubleshooting	
STE/ICE	0144 00-1
Test 26 fuel filter pressure drop	
STE/ICE	0121 00-1
Test 26 fuel filter pressure drop diagnostic troubleshooting	
STE/ICE	0145 00-1
Test 30 turbocharger outlet pressure	
STE/ICE	0122 00-1
Test 30 turbocharger outlet pressure diagnostic troubleshooting	
STE/ICE	0146 00-1
Test 32 air box pressure	
STE/ICE	0123 00-1
Test 32 air box pressure diagnostic troubleshooting	
STE/ICE	0147 00-1
Test 67 battery voltage	
STE/ICE	0124 00-1
Test 68 starter motor voltage	
STE/ICE	0125 00-1
Test 68 starter motor voltage diagnostic troubleshooting	
STE/ICE	0148 00-1
Test 69 starter negative cable voltage drop	
STE/ICE	0126 00-1
Test 69 starter negative cable voltage drop diagnostic troubleshooting	
STE/ICE	0149 00-1
Test 70 starter solenoid voltage	
STE/ICE	0127 00-1

INDEX, cont'd

<u>Subject</u>	<u>WP Sequence No.-Page No.</u>
Test 70 starter solenoid voltage diagnostic troubleshooting	
STE/ICE	0150 00-1
Test 71 starter current (average)	
STE/ICE	0128 00-1
Test 72 starter current (first peak)	
STE/ICE	0129 00-1
Test 73 battery resistance	
STE/ICE	0130 00-1
Test 74 starter circuit resistance	
STE/ICE	0131 00-1
Test 75 battery resistance change (pack)	
STE/ICE	0130 00-1
Test 80 battery current	
STE/ICE	0132 00-1
Test 82 generator output voltage	
STE/ICE	0133 00-1
Test 82 generator output voltage diagnostic troubleshooting	
STE/ICE	0151 00-1
Test 83 generator field voltage	
STE/ICE	0134 00-1
Test 83 generator field voltage diagnostic troubleshooting	
STE/ICE	0152 00-1
Test 84 generator negative cable voltage drop	
STE/ICE	0135 00-1
Test 84 generator negative cable voltage drop diagnostic troubleshooting	
STE/ICE	0153 00-1
Theory of Operation	0003 00-1
Thermostat	
Replacement	0237 00-1
Thermostatic Fan Speed Switch	
Replacement	0231 00-1
Throttle Valve (TV) Modulator	
Adust	0213 00-1
Tiedown plates	
Rear	
Replacement	0445 00-1
Tool Box Loops	
Replacement	0571 00-1
Torsion bar	
Replacement	0413 00-1
Torsion bar anchor	
Replacement	0414 00-1

INDEX, cont'd

<u>Subject</u>	<u>WP Sequence No.-Page No.</u>
Tow Pintle Extender Assembly	
M113A3	
Repair	0811 02-1
Tow Pintle Extender Kit	
M113A3	
Installation	0811 01-1
Tow Start Control Assembly	
Replacement	0391 00-1
Tow Start Control Cable Assembly	
Adjustment	0390 00-1
Tow Start Control Cover	
Replacement	0392 00-1
Towing Pintle	
Repair	0434 00-1
Replacement	0433 00-1
Track	
T130	
Replacement	0422 00-1
T150	
Replacement	0422 01-1
Track Drive Sprocket and Track Assemblies	
Reverse	0419 01-1
Track pad	
Track shoe	0424 01-1,0575 01-1
T150	
Replacement	0423 01-1
Track shoe pad	
T150	
Replacement	0424 01-1
Track shoe assembly	
Replacement	0423 00-1
Track shoe pad	
Replacement	0424 00-1
Track shoe stowage basket	0575 01-1
Track shroud and covers	
Replacement	0438 00-1
Track tension adjuster and mount	
Replacement	0419 00-1
Trailer harness	
Replacement	0375 00-1
Trailer lights don't work	0036 00-1
Trans filter clogged indicator malfunctions	0059 00-1
Trans oil hi temp indicator malfunctions	0057 00-1

INDEX, cont'd

<u>Subject</u>	<u>WP Sequence No.-Page No.</u>
Transducer	
Air box pressure	
Replacement.....	0327 00-1
Fuel return pressure	
Replacement.....	0325 00-1
Fuel supply pressure	
Replacement.....	0324 00-1
Turbo outlet pressure	
Replacement.....	0326 00-1
Transmission brake adjustment	
Check	0406 00-1
Transmission brakes	
Adjust	0394 00-1
Transmission controller wiring harness	
Replacement.....	0361 00-1
Transmission does not downshift in 1-4 position.....	0066 00-1
Transmission does not hold 1st position	0067 00-1
Transmission does not hold 2nd position	0068 00-1
Transmission does not hold 3rd position	0069 00-1
Transmission does not pivot steer	0071 00-1
Transmission does not reverse	0070 00-1
Transmission high temp indicator comes on	0072 00-1
Transmission low lube indicator comes on	0073 00-1
Transmission Mounts	
Replacement.....	0385 00-1
Transmission oil	
Cooler hoses, fittings, and mounting	
Replacement.....	0399 00-1
Level dipstick, filler tube, and adapter	
X200-4	
Replacement.....	0395 00-1
X200-4A	
Replacement.....	0396 00-1
Transmission oil and oil filter element	
Replacement.....	0398 00-1
Transmission oil drain tubes and bracket	
Replacement.....	0384 00-1
Transmission oil high temperature switch	
Replacement.....	0322 00-1
Transmission oil low pressure indicator malfunctions	0056 00-1

INDEX, cont'd

<u>Subject</u>	<u>WP Sequence No.-Page No.</u>
Transmission oil sampling valve and pressure switch	
Replacement	0400 00-1
Transmission oil supply and return hoses	
Replacement	0251 00-1
Transmission range controller lamp	
Replacement	0388 00-1
Transmission range controller switch	
Replacement	0389 00-1
Transmission range controller/bracket	
Used with solenoid-activated steering lock	
Replacement	0386 00-1
Transmission steering	
Adjust	0393 00-1
Transmission wiring harness	
Replacement	0360 00-1
Transmission won't upshift or shifts erratically in 1-4 position.....	0065 00-1
Transmitter	
Coolant temperature	
Replacement	0321 00-1
Fuel quantity	
All except M577A3 and M1068A3	
Replacement.....	0190 00-1
M577A3 and M1068A3	
Replacement.....	0191 00-1
Trim Vane	
Replacement	0458 00-1
Trim vane	
All Except M58	
Repair	0459 00-1
M58	
Repair	0460 00-1
Trim vane control linkage	
Repair	0461 00-1
Trim vane release	
Repair	0463 00-1
Replacement	0462 00-1
Tube	
Bulkhead Connection to Personnel Heater	
M577A3 and M1068A3	
Replacement.....	0687 00-1
External Cable	
Replacement	0905 00-1

INDEX, cont'd

<u>Subject</u>	<u>WP Sequence No.-Page No.</u>
Fire Extinguisher Cylinder Discharge	
Replacement.....	0899 00-1
Fire Extinguisher Turbine Cylinder Discharge	
M58	
Replacement.....	0900 00-1
From ramp control valve to bulkhead	
Replacement.....	0664 00-1
Fuel return	
M1064A3	
Replacement.....	0197 00-1
M113A3 , M1059A3, and M58	
Replacement.....	0195 00-1
M577A3 and M1068A3	
Replacement.....	0196 00-1
Fuel Vent	
M577A3 and M1068A3	
Replacement.....	0198 00-1
Personnel heater	
M577A3 and M1068A3	
Replacement.....	0700 00-1
Personnel Heater Fuel	
All Except M1064A3	
Replacement.....	0686 00-1
Thermostat	
Replacement.....	0238 00-1
Turbine access door	
M58	
Replacement.....	0485 00-1
Turbine access door gasket	
M58	
Replacement.....	0486 00-1
Turbine access door hinges	
M58	
Replacement.....	0487 00-1
Turbo outlet pressure transducer	
Replacement.....	0326 00-1
Turnbuckle parts generator	
Replacement.....	0254 00-1
U	
Unsafe ramp	
Lower	0513 00-1
Raise	0513 00-1

INDEX, cont'd

<u>Subject</u>	<u>WP Sequence No.-Page No.</u>
Upper and lower service brake pedal	
Replacement	0409 00-1
Upper Coolant Hose and Tube	
Replacement	0232 00-1
Utility outlet lead assembly	
M577A3 and M1068A3	
Replacement	0377 00-1
Utility outlet receptacle	
Replacement	0265 00-1
Utility outlet receptacles	
Rear	
M577A3 and M1068A3	
Replacement.....	0378 00-1
V	
Valve	
Front Bilge	
Replacement	0633 00-1
Fuel Shutoff	
Coolant Heater	
Replacement.....	0720 00-1
Valve Assembly	
Fuel Shut-off	
M113A3, M1059A3, and M58	
Replacement.....	0684 00-1
Variable speed drive	0359 01-1
Fan	
Replacement (Old Configuration)	0249 00-1
Replacement (New Configuration)	0249 01-1
Controller.....	0250 01-1
Fan Drive and Override Switch	
Replacement (New Configuration)	0231 01-1
Generator	
Replacement (Old Configuration)	0249 00-1
Replacement (New Configuration)	0249 01-1
Variable speed fan drive valve (Old Configuration)	0231 00-1
Override switch (New Configuration).....	0231 01-1
Vehicle batteries discharge with external AC power applied	
M1068A3 only	0103 00-1
Vehicle will not accept external AC power	
M1068A3 only	0104 00-1
Vehicle will not accept inverter AC power	
M1068A3 only	0105 00-1

INDEX, cont'd

<u>Subject</u>	<u>WP Sequence No.-Page No.</u>
Vent fitting	
Battery box	
M58	
Replacement.....	0355 00-1
Ventilating Fan Assembly	
Replacement.....	0247 00-1
Ventilating Fan Drive Belt	
Adjustment.....	0242 00-1
Replacement.....	0243 00-1
Ventilating Fan Drive Pulley	
Replacement.....	0244 00-1
Ventilation fan	
M577A3 and M1068A3	
Replacement.....	0383 00-1
VFM	
Vision Block Locks and Seals	
Driver's Hatch	
Replacement.....	0535 00-1
Vision block locks and seals	
Commander's cupola	
M1064A3	
Replacement.....	0491 00-1
M113A3 and M1059A3, M58	
Replacement.....	0490 00-1
Vision Port	
Ramp	
M58	
Replacement/Repair.....	0586 00-1
Voltage regulator	
Adjustment.....	0256 00-1
W	
W1, W2, and NATO Slave Cables	
Stowage Brackets for	
M1068A3 and M577A3	
Replacement.....	0626 01-1
Wait indicator flashes during start attempts (preglow or afterglow).....	0018 00-1
Wait indicator light doesn't light.....	0019 00-1
Warning Light Panel	
All Except M58	
Replacement.....	0292 00-1
Instrument	
Replacement.....	0288 00-1

INDEX, cont'd

<u>Subject</u>	<u>WP Sequence No.-Page No.</u>
Warning light panel Assembly	
All Except M58	
Replacement.....	0291 00-1
Warning Lights	
Instrument Panel	
Replacement.....	0287 00-1
Warning Panel Lights	
M58	
Replacement.....	0294 01-1
Warning panel lights	
All Except M58	
Replacement.....	0294 00-1
Warning panel wiring harness	
Replacement.....	0374 00-1
Water barrier	
M113A3, M577A3, and M1068A3 only	
Replacement.....	0456 00-1
Water barrier loop and strap	
M113A3, M577A3, and M1068A3 only	
Replacement.....	0457 00-1
Water/Ration Heater	
Mount Bracket	
(M113A3 Only)	
Replace.....	0811 00-1
Power Cable	
(M113A3 Only)	
Replace.....	0810 00-1
Webbing straps	
Replacement.....	0569 00-1
Wheel	
Idler	
Replacement.....	0425 00-1
Road	
Replacement.....	0426 00-1
Windshield	
Driver's	
Replacement.....	0739 00-1
Stowage bag, straps, and decal	
Replacement.....	0740 00-1
Stowage Bracket	
M1064A3	
Replacement.....	0614 00-1

INDEX, cont'd

<u>Subject</u>	<u>WP Sequence No.-Page No.</u>
Wire harness	
Radiac	
M113A3, M577A3, and M1068A3	
Replacement.....	0376 00-1
Wire Rope and Pulleys	
M1064A3	
Replacement.....	0658 00-1
Wire rope and pulleys	
All Except M1064A3	
Replacement.....	0657 00-1
Wiring Harness	
Air Box Heater	
Replacement.....	0205 00-1
Coolant Heater	
Replacement.....	0735 00-1
Coolant Pump to Heater	
Replacement.....	0733 00-1
M13 NBC Heater	
(M577A3)	
Replace.....	0808 00-1
M14 NBC Heater	
(M113A3 Ambulance)	
Replace.....	0807 00-1
M3 NBC Heater (M1059A3)	
Replace.....	0806 00-1
Repair	0382 00-1
STE/ICE Crew	
M1064A3	
Replacement.....	0881 00-1
STE/ICE Crew, M113A3 and M1059A3	
Replacement.....	0878 00-1
STE/ICE Crew, M577A3 and M1068A3	
Replacement.....	0879 00-1
STE/ICE Engine	
Replacement.....	0882 00-1
Wiring harness	
3W1	0359 01-1
Battery-to-radio (Left Side)	
M113A3 and M1059A3	
Replacement.....	0369 00-1
Engine	
Replacement.....	0359 00-1

INDEX, cont'd

<u>Subject</u>	<u>WP Sequence No.-Page No.</u>
Instrument panel battery-generator gauge	
Replace.....	0289 00-1
M13 NBC Heater	
M1068A3 only	
Replace.....	0809 00-1
M577A3	
Replace.....	0803 00-1
■ Rear main	
M1064A3	
Replacement.....	0364 00-1
M1068A3	
Replacement.....	0365 00-1
■ M113A3, M1059A3, and M58	
Replacement.....	0362 00-1
M577A3	
Replacement.....	0363 00-1
Right headlight	
Replace.....	0373 00-1
Smoke grenade launcher	
■ M113A3, M1059A3, and M58	
Replacement.....	0366 00-1
Steering lock switch	
All Except M58	
Replacement.....	0367 00-1
M58	
Replacement.....	0367 01-1
Transmission	
Replacement.....	0360 00-1
Transmission controller	
Replacement.....	0361 00-1
Warning panel	
Replacement.....	0374 00-1
Wiring harness (right side)	
Battery-to-radio	
M113A3	
Replacement.....	0370 00-1
Wiring Harnesses, Cables, Leads	
Chemical Alarm Interface	
M113A3	
Replacement.....	0923 00-1
Circuit 44A, Power Control Enclosure Leads	
M1068A3	
Replacement.....	0829 00-1

INDEX, cont'd

Subject

WP Sequence No.-Page No.

Wiring Harnesses, cables, leads

W251

M1068A3

Replacement..... 0852 00-1

W42

M1068A3

Replacement..... 0852 00-1

W43

M1068A3

Replacement..... 0852 00-1

Wiring harnesses, cables, leads

W124

M1068A3

Replacement..... 0855 00-1

Wiring Harnesses, cables, leads:

LAN A or B (W103/W104)

M1068A3

Replacement..... 0854 00-1

W45

M1068A3

Replacement..... 0853 00-1

Wiring harnesses, cables, leads:

W126

M1068A3

Replacement..... 0856 00-1

By Order of the Secretary of the Army:

Official:



JOEL B. HUDSON

*Administrative Assistant to the
Secretary of the Army*

0026301

ERIC K. SHINSEKI
*General, United States Army
Chief of Staff*

DISTRIBUTION: To be distributed in accordance with the initial distribution requirements for IDN: 371205, requirements for TM 9-2350-277-20-4.

RECOMMENDED CHANGES TO PUBLICATIONS AND BLANK FORMS	Use Part II (reverse) for Repair Parts and Special Tools Lists (RPSTL) and Supply Catalogs/Supply Manuals (SC/SM).	Date 23 JUL 01
For use of this form, see AR 25-30; the proponent agency is ODISC4.		
TO: (Forward to proponent of publication or form) (Include ZIP Code)		FROM: (Activity and location) (include ZIP code) COMMANDER COMPANY A, 216 CAV FORT KNOX, KY 40121

PART I - ALL PUBLICATIONS (EXCEPT RPSTL AND SC/SM) AND BLANK FORMS

PUBLICATION/FORM NUMBER TM 9-2350-277-20-4	DATE 02 JAN 01	TITLE Unit Maintenance Manual for M113A3 FOV
---	-------------------	---

ITEM	PAGE	PARA	LINE	FIGURE NO.	TABLE	RECOMMENDED CHANGES AND REASON
	0014 00-2					STEP b. THE SCREWS (4) ON BRACKET (2) MUST BE TORQUED PLEASE ADD TORQUE INFORMATION.
	0023 00-34			5 (SH15)		THERE ARE FOUR CLAMPS (144) ON WIRING HARNESS (217), NOT THREE AS SHOWN. PLEASE CORRECT

*Reference to line numbers within the paragraph or subparagraph.

TYPED NAME, GRADE OR TITLE	TELEPHONE EXCHANGE/AUTOVON, PLUS EXTENSION	SIGNATURE

TO: <i>(Forward direct to addressee listed in publication)</i>	FROM: <i>(Activity and location) (Include Zip Code)</i>	DATE
--	---	------

PART II - REPAIR PARTS AND SPECIAL TOOL LISTS AND SUPPLY CATALOGS/SUPPLY MANUALS

PUBLICATION NUMBER			DATE			TITLE		
PAGE NO.	COLM NO.	LINE NO.	NATIONAL STOCK NUMBER	REFERENCE NO.	FIGURE NO.	ITEM NO.	TOTAL NO. OF MAJOR ITEMS SUPPORTED	RECOMMENDED ACTION

PART III - REMARKS *(Any general remarks or recommendations, or suggestions for improvement of publications and blank forms. Additional blank sheets may be used if more space is needed.)*

TYPED NAME, GRADE OR TITLE	TELEPHONE EXCHANGE/AUTOVON, PLUS EXTENSION	SIGNATURE
----------------------------	--	-----------

RECOMMENDED CHANGES TO PUBLICATIONS AND BLANK FORMS For use of this form, see AR 25-30; the proponent agency is ODISC4.	Use Part II (<i>reverse</i>) for Repair Parts and Special Tools Lists (RPSTL) and Supply Catalogs/Supply Manuals (SC/SM).	Date
---	---	------

TO: (<i>Forward to proponent of publication or form</i>) (<i>Include ZIP Code</i>)	FROM: (<i>Activity and location</i>) (<i>include ZIP code</i>)
---	---

PART I - ALL PUBLICATIONS (EXCEPT RPSTL AND SC/SM) AND BLANK FORMS

PUBLICATION/FORM NUMBER TM 9-2350-277-20-4	DATE 02 JAN 01	TITLE Unit Maintenance Manual for M113A3 FOV
---	-------------------	---

ITEM	PAGE	PARA	LINE	FIGURE NO.	TABLE	RECOMMENDED CHANGES AND REASON

**Reference to line numbers within the paragraph or subparagraph.*

TYPED, GRADE OR TITLE	TELEPHONE EXCHANGE/AUTOVON, PLUS EXTENSION	SIGNATURE
-----------------------	--	-----------

TO: <i>(Forward direct to addressee listed in publication)</i>	FROM: <i>(Activity and location) (Include Zip Code)</i>	DATE
--	---	------

PART II - REPAIR PARTS AND SPECIAL TOOL LISTS AND SUPPLY CATALOGS/SUPPLY MANUALS

PUBLICATION NUMBER			DATE			TITLE		
PAGE NO.	COLM NO.	LINE NO.	NATIONAL STOCK NUMBER	REFERENCE NO.	FIGURE NO.	ITEM NO.	TOTAL NO. OF MAJOR ITEMS SUPPORTED	RECOMMENDED ACTION

PART III - REMARKS *(Any general remarks or recommendations, or suggestions for improvement of publications and blank forms. Additional blank sheets may be used if more space is needed.)*

TYPED NAME, GRADE OR TITLE	TELEPHONE EXCHANGE/AUTOVON, PLUS EXTENSION	SIGNATURE
----------------------------	--	-----------

RECOMMENDED CHANGES TO PUBLICATIONS AND BLANK FORMS For use of this form, see AR 25-30; the proponent agency is ODISC4.	Use Part II (<i>reverse</i>) for Repair Parts and Special Tools Lists (RPSTL) and Supply Catalogs/Supply Manuals (SC/SM).	Date
---	---	------

TO: (<i>Forward to proponent of publication or form</i>) (<i>Include ZIP Code</i>)	FROM: (<i>Activity and location</i>) (<i>include ZIP code</i>)
---	---

PART I - ALL PUBLICATIONS (EXCEPT RPSTL AND SC/SM) AND BLANK FORMS

PUBLICATION/FORM NUMBER TM 9-2350-277-20-4	DATE 02 JAN 01	TITLE Unit Maintenance Manual for M113A3 FOV
---	-------------------	---

ITEM	PAGE	PARA	LINE	FIGURE NO.	TABLE	RECOMMENDED CHANGES AND REASON

**Reference to line numbers within the paragraph or subparagraph.*

TYPED, GRADE OR TITLE	TELEPHONE EXCHANGE/AUTOVON, PLUS EXTENSION	SIGNATURE
-----------------------	--	-----------

TO: <i>(Forward direct to addressee listed in publication)</i>	FROM: <i>(Activity and location) (Include Zip Code)</i>	DATE
--	---	------

PART II - REPAIR PARTS AND SPECIAL TOOL LISTS AND SUPPLY CATALOGS/SUPPLY MANUALS

PUBLICATION NUMBER			DATE			TITLE		
PAGE NO.	COLM NO.	LINE NO.	NATIONAL STOCK NUMBER	REFERENCE NO.	FIGURE NO.	ITEM NO.	TOTAL NO. OF MAJOR ITEMS SUPPORTED	RECOMMENDED ACTION

PART III - REMARKS *(Any general remarks or recommendations, or suggestions for improvement of publications and blank forms. Additional blank sheets may be used if more space is needed.)*

TYPED NAME, GRADE OR TITLE	TELEPHONE EXCHANGE/AUTOVON, PLUS EXTENSION	SIGNATURE
----------------------------	--	-----------

THE METRIC SYSTEM AND EQUIVALENTS

LINEAR MEASURE

1 Centimeter = 10 Millimeters = 0.01 Meters = 0.3937 Inches
 1 Meter = 100 Centimeters = 1000 Millimeters = 39.37 Inches
 1 Kilometer = 1000 Meters = 0.621 Miles

WEIGHTS

1 Gram = 0.001 Kilograms = 1000 Milligrams = 0.035 Ounces
 1 Kilogram = 1000 Grams = 2.2 Lb.
 1 Metric Ton = 1000 Kilograms = 1 Megagram = 1.1 Short Tons

LIQUID MEASURE

1 Milliliter = 0.001 Liters = 0.0338 Fluid Ounces
 1 Liter = 1000 Milliliters = 33.82 Fluid Ounces

SQUARE MEASURE

1 Sq. Centimeter = 100 Sq. Millimeters = 0.155 Sq. Inches
 1 Sq. Meter = 10,000 Sq. Centimeters = 10.76 Sq. Feet
 1 Sq. Kilometer = 1,000 Sq. Meters = 0.386 Sq. Miles

CUBIC MEASURE

1 Cu. Centimeter = 1000 Cu. Millimeters = 0.06 Cu. Inches
 1 Cu. Meter = 1,000,000 Cu. Centimeters = 35.31 Cu. Feet

TEMPERATURE

$5/9 (^{\circ}\text{F} - 32) = ^{\circ}\text{C}$
 212° Fahrenheit is equivalent to 100° Celsius
 90° Fahrenheit is equivalent to 32.2° Celsius
 32° Fahrenheit is equivalent to 0° Celsius
 $(9/5 \times ^{\circ}\text{C}) + 32 = ^{\circ}\text{F}$

TO CHANGE	TO	MULTIPLY BY
Inches	Centimeters	2.540
Feet	Meters	0.305
Yards	Meters	0.914
Miles	Kilometers	1.609
Square Inches	Square Centimeters	6.451
Square Feet	Square Meters	0.093
Square Yards	Square Meters	0.836
Square Miles	Square Kilometers	2.590
Acres	Square Hectometers	0.405
Cubic Feet	Cubic Meters	0.028
Cubic Yards	Cubic Meters	0.765
Fluid Ounces	Millimeters	29.573
Pints	Liters	0.473
Quarts	Liters	0.946
Gallons	Liters	3.785
Ounces	Grams	28.349
Pounds	Kilograms	0.454
Short Tons	Metric Tons	0.907
Pound-Feet	Newton-Meters	1.356
Pounds per Square Inch	Kilopascals	6.895
Miles per Gallon	Kilometers per Liter	0.425
Miles per Hour	Kilometers per Hour	1.609

TO CHANGE	TO	MULTIPLY BY
Centimeters	Inches	0.394
Meters	Feet	3.280
Meters	Yards	1.094
Kilometers	Miles	0.621
Square Centimeters	Square Inches	0.155
Square Meters	Square Feet	10.764
Square Meters	Square Yards	1.196
Square Kilometers	Square Miles	0.386
Square Hectometers	Acres	2.471
Cubic Meters	Cubic Feet	35.315
Cubic Meters	Cubic Yards	1.308
Milliliters	Fluid Ounces	0.034
Liters	Pints	2.113
Liters	Quarts	1.057
Liters	Gallons	0.264
Grams	Ounces	0.035
Kilograms	Pounds	2.205
Metric Tons	Short Tons	1.102
Newton-Meters	Pound-Feet	0.738
Kilopascals	Pounds per Square Inch	0.145
Kilometers per Liter	Miles per Gallon	2.354
Kilometers per Hour	Miles per Hour	0.621

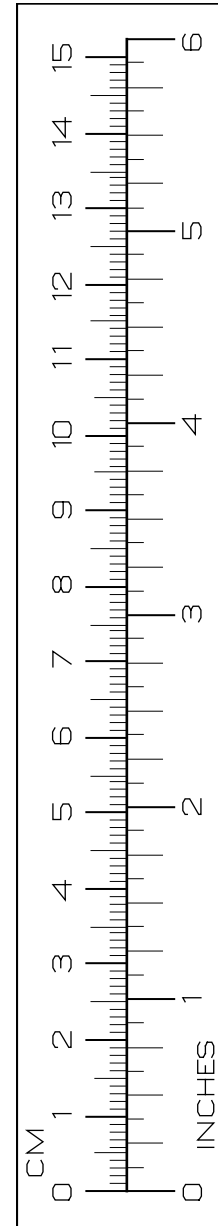

PIN: 078492-000